

JMA[®]



**SUPPLEMENTO
SUPPLEMENT**

2021.01

JMA[®]

ESPECIALISTA
SPECIALIST



LLAVES
KEYS





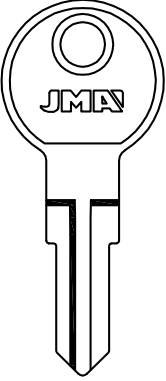
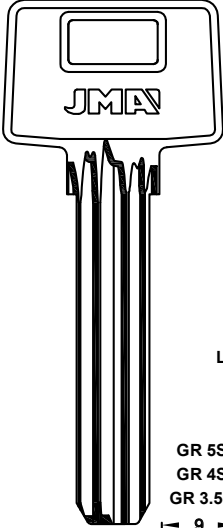
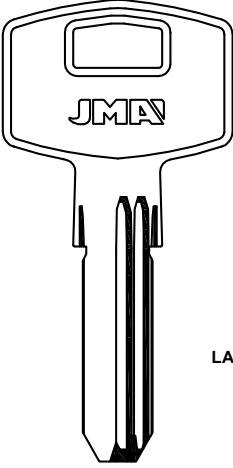
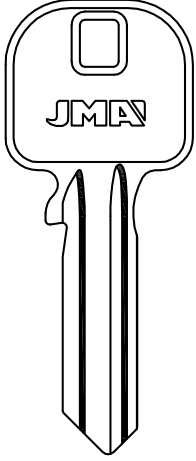















SUPLEN

MORE INFO:
[ECATALOGO](#)

FOR: GTV®	FOR: HUGO®	FOR: NOORI®	FOR: YETI®
 <p data-bbox="165 734 256 801">GTV-12 NEW</p>	 <p data-bbox="632 510 671 533">LAT.</p> <p data-bbox="587 607 651 674">GR 5S GR 4S GR 3.5S</p> <p data-bbox="571 680 692 748">9 2.95 HGO-2D</p> <p data-bbox="571 770 639 801">NEW</p>	 <p data-bbox="959 510 999 533">LAT.</p> <p data-bbox="820 680 941 748">8.6 2.35 NOR-1</p> <p data-bbox="708 786 906 808">FOR: IBFM® NEW</p>	 <p data-bbox="1091 689 1150 707">AD195</p> <p data-bbox="1082 734 1310 763">YET-18 YET-18D</p> <p data-bbox="1098 786 1198 808">FOR: LOB® NEW</p>





FOR:
 GTV® (D)
 HUGO® (D)
 NOORI® (D)
 YETI® (RC)



FOR: DAEWOO®		FOR: MAHINDRA®	
 <p>LAT.</p> <p>DAE-3.P5 NEW</p>	                   	<p>TP32CS</p> <p>TP00</p>	<p>LAT.</p> <p>MHN-1.P NEW</p> <p>TPX8+</p> <p>TP08</p> <p>TP00</p>

FOR:
DAEWOO®
MAHINDRA®

VEHÍCULOS RELACIONADOS CON LAS NUEVAS LLAVES TRANSPONDER VEHICLES RELATED TO THE NEW TRANSPONDER KEYS

FOR:					TRS-5000			TRS-5000 EVO	Programming TP	
					Basic	TPXClonner	TPH Clonner			
CHEVROLET (USA)®	SPARK	2015-	SOK/CR	DAE-3P5				TP32CS		
MAHINDRA®	SCORPIO	2012-2015	MEG/CR	MHN-1P			TPX8+	TP08		

OTROS CAMBIOS - OTHER CHANGES

REF. JMA	ESTADO ACTUAL /CURRENT STATUS
227G	Descatalogado- Discontinued
1608G	Descatalogado- Discontinued



FOR:	JMA				
HUGO®	HGO-2D	CAPRI	F-1	P-1	
	HGO-2D	CAPRI S.	F-1	P-1	
	HGO-2D	NEO-DAKKI	F-1	P-1	
NOORI®	NOR-1	CAPRI	F-1	P-1	
	NOR-2	CAPRI S.	F-1	P-1	
	NOR-3	NEO-DAKKI	F-1	P-1	
MAHINDRA®	MHN-1P	CAPRI	F-11	P-11	
	MHN-1P	CAPRI S.	F-11	P-11	
	MHN-1P	NEO-DAKKI	F-11	P-11	

MÁQUINAS - MACHINES



CAPRI



CAPRISMART



NEO

FRESAS - CUTTERS

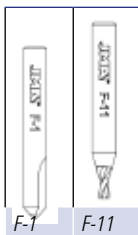

PALPADORES-TRACERS



JMA[®]

NEW

BT MULTI USER PRO

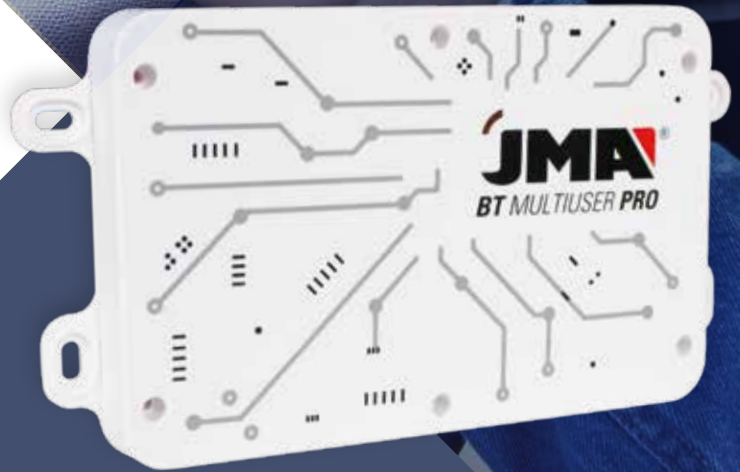

EL TELEMANDO EN TU SMARTPHONE

AHORA, CON CAPACIDAD PARA MÁS DE 100 USUARIOS

THE REMOTE CONTROL ON YOUR SMARTPHONE

NOW IT CAN BE USED BY OVER 100 DIFFERENT USERS

BT MULTIUSER, el sistema JMA para apertura de puertas de garaje, vallas y puertas de acceso con el teléfono móvil, evoluciona con la llegada de BT MULTIUSER PRO.

Ahora podrá gestionar y enviar permisos de apertura de un mismo acceso a más de 100 usuarios. Además, cuenta con una nueva base de alimentación con resistencia a la intemperie IP66.

BT MULTIUSER - the JMA system for opening garage doors, gates and access doors using your smartphone - has been taken to the next level with BT MULTIUSER PRO.

Now you can manage and send access permissions for a single point of access to over 100 different users. The new power base also comes with an IP66 protection rating.

ETRAINING
BT MULTIUSER PRO
[CLICK](#)

PACKS DISPONIBLES / AVAILABLE PACKS

ADMIN

ADMINISTRADORES + USUARIOS INVITADOS / ADMINISTRATORS + GUEST USERS



NEW

BT SLIM

BT SLIM es el nuevo telecomando JMA para la apertura de puertas de garaje, vallas y puertas acceso mediante teléfono móvil. Basta con colocar el dispositivo en la parte trasera de su smartphone, vincularlo vía Bluetooth a la APP JMARemoteSLIM y pulsar en ella el botón de apertura.

Gracias a su diseño fino y ligero, BT SLIM se lleva cómodamente en el móvil y se guarda en cualquier bolsillo. Además, incorpora otros atractivos como la función de disparador remoto de la cámara de fotos del teléfono y otros extras que harán más cómodo el manejo de su smartphone.

BT SLIM is the new JMA remote control for opening garages, gates and other doors using your mobile. Simply attach the device to the rear of your smartphone, connect via Bluetooth to the JMARemoteSLIM app and press the open button.

Thanks to its thin lightweight design, BT SLIM can be attached to your mobile comfortably and kept in any pocket. It also offers a number of other attractive features, such as a remote mobile camera shutter button and other extras that will make using your smartphone more convenient.



ETRAINING
BT SLIM

[CLICK](#)

SENCILLO MANEJO MEDIANTE APPS

SIMPLE TO USE VIA ITS APPS

4 MANDOS EN 1

4 REMOTES IN 1

LIGERO Y FÁCIL DE LLEVAR

LIGHTWEIGHT AND EASY TO CARRY

BT Slim se maneja mediante dos APPs:

- JMARemotesPRO, para el duplicado de los mandos originales en el BT Slim
- JMARemoteSLIM, para la apertura de puertas de garaje, vallas y puertas de acceso.

BT Slim can be used via two apps:

- JMARemotesPRO for duplicating original remote controls on the BT Slim
- JMARemoteSLIM for opening garages, gates and other doors.

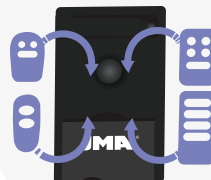

Copia el 95% de los códigos fijos y más de 40 marcas Rolling Code.

It copies 95% of fixed codes and more than 40 rolling code brands.

Péguelo en la parte trasera de su smartphone. Es tan fino que se lleva fácilmente en el bolsillo del pantalón, en bolsos pequeños, chaquetas, etc.

Attach it to the rear of your smartphone. It's so thin that it easily fits in your trouser pocket, in small bags, jackets, etc.

ÚSELO TAMBIÉN COMO UN TELEMANDO TRADICIONAL

USE IT ALSO AS A TRADITIONAL REMOTE CONTROL

DISPARADOR DE CÁMARA DE FOTOS

REMOTE CAMERA SHUTTER BUTTON

CARCASAS
KEY SHELLS



SUPLEMENTO-SUPPLEMENT
2021.01 CKS.06

THE KEY TO EXCELLENCE
GLOBALLY UNLOCKING MILLIONS OF DOORS DAILY



CARCASAS - KEY SHELLS

®

REF. JMA

DETAILS

ORIGINAL

FOR: CITROËN®

MLCIT-1.P16



PEU-1C1





ÉXITO DE ETRAINING.JMA.ES, LA NUEVA PLATAFORMA DE FORMACIÓN ONLINE PARA PROFESIONALES

THE SUCCESS OF ETRAINING.JMA.ES, THE NEW ONLINE TRAINING PLATFORM FOR PROFESSIONALS

A finales de 2020, JMA presentó etraining.jma.es, su plataforma de formación online dirigida a profesionales de la ferretería, la cerrajería, etc. El objetivo, ayudarles a sacar el máximo partido a los productos JMA y mejorar el servicio a sus clientes.

Towards the end of 2020, JMA launched etraining.jma.es - its online training platform aimed at hardware, locksmithing and other such professionals. The goal was to help them make the most of JMA products and improve the service given to their customers.

Etraining.jma.es ofrece una gran cantidad de contenidos audiovisuales: vídeos de presentación de producto y completos videotutoriales acerca del manejo de las máquinas duplicadoras de llaves, telemandos, tecnología transponder y el software y aplicaciones de JMA.

A broad range of audiovisual content can be found on etraining.jma.es: product presentation videos and complete video tutorials on using key cutting machines, remote controls, transponder technology and JMA software and applications.

Estos contenidos se complementan con lo que, sin duda, es uno de los principales atractivos de etraining.jma.es: las sesiones formativas online en directo mediante webinars (seminarios web) con los profesionales de JMA.

This content is supported by what is no doubt one of the main attractive features of etraining.jma.es: the live online training sessions based on webinars (web seminars) with JMA professionals.

Los webinars versan sobre aspectos técnicos y funcionales de los productos JMA y también se van a emplear para presentar los lanzamientos de nuevos productos que la marca incorpore.

These webinars explain technical and functional aspects of JMA products and will also be used to present the new product launches planned by the brand.



Gran número de usuarios registrados

Para disfrutar de estos exclusivos contenidos al completo, es preciso registrarse. Es ahí, en el número de registros alcanzados, donde se puede medir el éxito de la plataforma en sus primeros meses de vida.

Etraining.jma.es cuenta ya con más de 1.000 profesionales registrados, procedentes de casi 60 países de los cinco continentes, y con un fuerte crecimiento mensual de los registros.

De esta manera, JMA está cumpliendo su objetivo de estar más cerca de los profesionales del sector, al ofrecer un contenido de su máximo interés adaptado a sus necesidades y tiempo, fomentando a la vez su interacción y participación.

High number of registered users

Users need to register in order to fully enjoy this exclusive content. This number of registered users can be used to measure the success of the platform in its early months.

Over 1,000 professionals in close on 60 countries on all five continents have already registered on etraining.jma.es, and that number of registered users continues to grow each month.

As a result, JMA is meeting its target to get closer to the professionals in this sector by offering highly relevant content adapted to their needs and availability while also encouraging engagement and interaction.

SHGN7_S001_S001_T166.
MOV
SHGN7_S001_S001_T168.
MOV
SHGN7_S001_S001_T167.
MOV

El transponder TPX7 The TPX7 transponder



Presentación del nuevo transponder para la copia del DST80, utilizado en marcas como Ford®, Hyundai® y Kia. El webinar recoge las principales características del transponder y el proceso de copia de llaves originales de vehículo.

Presentation of the new transponder for copying the DST80 used by such brands as Ford®, Hyundai® and Kia. This webinar talks about the main features of the transponder and the process for copying original vehicle keys.

Próximos webinars:

- Multicode: máquina electrónica 'todo en uno'
- Introducción a la tecnología transponder
- El transponder TPX8+

Upcoming webinars:

- Multicode: an "all-in-one" electronic machine
- Introduction to transponder technology
- The TPX8+ transponder

Primeros webinars realizados

The first webinars

Introducción a la tecnología de telemandos

Introduction to remote control technology



Una sencilla introducción al funcionamiento y sistemas de copia de los mandos JMA para puertas de garaje, vallas y puertas de acceso. Dirigido tanto a profesionales que desean incorporar el duplicado de mandos como a aquellos que quieran profundizar.

A simple introduction to the operation and copying systems for JMA remote controls for garage doors, gates and other access points. Aimed at all those professionals wishing to include remote control copying in their portfolio, as well as those wishing to learn more about this subject.

Abre el garaje con tu teléfono móvil Open the garage with your smartphone



En este webinar presentamos los dispositivos BT Multiuser PRO y BT Slim de JMA para la apertura de puertas de garaje, vallas y puertas de acceso con el smartphone del usuario, detallando sus funciones y modos de copia.

In this webinar, we present the BT Multiuser PRO and BT Slim devices from JMA for opening garage doors, gates and other access points with a user's smartphone, explaining their functions and copy modes.



ACTUALIZACIONES SOFTWARE - SOFTWARE UPDATES

REF	PROFIL	SERIE	FOR:	FILE
TP00FO-24P	4001-9001	RANGE ROVER@/ JAGUAR@/VOLVO@	255P
TP20FO-24P	4001-9001	RANGE ROVER@/ JAGUAR@/VOLVO@	255P
TP33FO-24P	4001-9001	RANGE ROVER@/ JAGUAR@/VOLVO@	255P
TPX2FO-24P	4001-9001	RANGE ROVER@/ JAGUAR@/VOLVO@	255P
TPX4FO-24P	4001-9001	RANGE ROVER@/ JAGUAR@/VOLVO@	255P
TPX5FO-24P	4001-9001	RANGE ROVER@/ JAGUAR@/VOLVO@	255P
TPX6FO-24P	4001-9001	RANGE ROVER@/ JAGUAR@/VOLVO@	255P
TP00FO-24P2	4001-9001	RANGE ROVER@/ JAGUAR@/VOLVO@	255P
TP00FO-24PTL	4001-9001	RANGE ROVER@/ JAGUAR@/VOLVO@	255P
TP00FO-24PTL2	4001-9001	RANGE ROVER@/ JAGUAR@/VOLVO@	255P
FO-24C1	4001-9001	RANGE ROVER@/ JAGUAR@/VOLVO@	255P
FO-24C2	4001-9001	RANGE ROVER@/ JAGUAR@/VOLVO@	255P
FO-24C4	4001-9001	RANGE ROVER@/ JAGUAR@/VOLVO@	255P
FO-24C5	4001-9001	RANGE ROVER@/ JAGUAR@/VOLVO@	255P
FO-24C6	4001-9001	RANGE ROVER@/ JAGUAR@/VOLVO@	255P
FO-24C7	4001-9001	RANGE ROVER@/ JAGUAR@/VOLVO@	255P
FO-24C8	4001-9001	RANGE ROVER@/ JAGUAR@/VOLVO@	255P
FO-24C9	4001-9001	RANGE ROVER@/ JAGUAR@/VOLVO@	255P
ORIGINALYALE@1	ABC10001-AEH26822	YALE@2000 SERIES P1-H2 5+5 puntos	1245P
MUL-T16P	123456	GARDESA TIGER@ (7 pins)	159P
MQ-2	123456789	MARC E1000	1030
MQ-1D	1234	Serie 280 / 22X	1031
MQ-1I	1234	Serie 280 / 22X	1031
ORIGINALCISA @1	1234	RS3 74 Tip Old	1211P
ORIGINALMQ@	1234	MARC E5000	1247P
ORIGINALEVVA@2	12345	ICS	1249P
BRI-30	01004-12987	STANDERS FIX+	1251P
FO-24C3	P0004-P9710	FORD@ F-150	945P
ORIGINALHYUNDAI@	CK....	0001-2500	SMART KEY	1228P
KE-6	1234	2000S	980P
KE-7	1234	2000S	980P
KE-6	178	2000S Only STEP 15F	129P

REF	PROFIL	SERIE	FOR:	FILE
KE-7	178	2000S Only STEP 15F	129P
ORIGINALWIN1	012345678	VS MP1-VS Clamp	998
TPX7FO-24P	10001-11500	Ford@ (USA)	255P
TPX7FO-24P	80001-81500	Ford@ (USA)	255P
TPX7FO-24P	0001-4000		255P
TPX7FO-24TL2	10001-11500	Ford@ (USA)	255P
TPX7FO-24TL2	80001-81500	Ford@ (USA)	255P
TPX7FO-24TL2	0001-4000		255P
TPX7FO-15DCPX	0001-1706		516
TPX7FO-30DPX	0001-1706		516
TPX7HY-11DP1	T....	0001-2500	Side 3, 8 pins	3789
TPX7HY-11DP1	F....	1-2295	Sonata Side 3, 10 pins	3850
TPX7HY-11P1	P....	0001-2500	Side 3, 8 pins	4789
TPX7HY-19DP1	1001-3500		901P
TPX7HY-19DP1	X....	1001-3500		901P
TPX7HY-19DP1	T....	1001-3500		901P
TPX7HY-19DP1	TB...	1001-3500		901P
TPX7HY-19P1	C....	1001-3500		959P
TPX7HY-19P1	UM....	1001-3500		959P
TPX7HY-20P1	C....	0001-2900		7153P
TPX7HY-20P1	KC....	0001-2900		7153P
TPX7KI-7P	J0001-J2500	HYUNDAI@ / KIA@ Laser key	438P
TPX7KI-7P	G0001-G2500	HYUNDAI@ / KIA@ Laser key	438P
TPX7KI-7P	K....	0001-2500	HYUNDAI@ / KIA@ Laser key	438P
TPX7KI-7P	T....	0001-2500	HYUNDAI@ / KIA@ Laser key	438P
TPX7KI-7P	P....	0001-2500	HYUNDAI@ / KIA@ Laser key	438P
TPX7KI-7P	HK....	0001-2500	HYUNDAI@ / KIA@ Laser key	438P
TPX7KI-7P	E0001-E2500	HYUNDAI@ / KIA@ Laser key	438P
TPX7KI-7P	V....	0001-2500	HYUNDAI@ / KIA@ Laser key	438P
TPX7KI-7P	M....	0001-2500	HYUNDAI@ / KIA@ Laser key	438P
TPX7KI-7P	LK....	0001-2500	HYUNDAI@ / KIA@ Laser key	438P
TPX70P-11P1	Z....	0001-6000	OPEL@ - CADILLAC@	259P
TPX70P-11P1	V0001-V5718	GMC@	262P
VO-2DP	AH....	2001-2830		2122
VO-2DP	AH....	4001-5151		2122
VO-2DP	AH...	1-854		2122
VO-2DP	AH....	7101-8154		2122
VO-2DP	AH....	1001-1918		2123



ACTUALIZACIONES SOFTWARE - SOFTWARE UPDATES

REF	PROFIL	SERIE	FOR:	FILE
VO-2DP	AH...	6001-7086		2123
VO-2DP	AH...	3001-3890		2123
VO-2DP	AH...	8201-9282		2123
VO-2DP1	AH...	2001-2830		2122
VO-2DP1	AH...	4001-5151		2122
VO-2DP1	AH...	1-854		2122
VO-2DP1	AH...	7101-8154		2122
VO-2DP1	AH...	1001-1918		2123
VO-2DP1	AH...	6001-7086		2123
VO-2DP1	AH...	3001-3890		2123
VO-2DP1	AH...	8201-9282		2123
TP00VO-2DP	AH...	2001-2830		2122
TP00VO-2DP	AH...	4001-5151		2122
TP00VO-2DP	AH...	1-854		2122
TP00VO-2DP	AH...	7101-8154		2122
TP00VO-2DP	AH...	1001-1918		2123
TP00VO-2DP	AH...	6001-7086		2123
TP00VO-2DP	AH...	3001-3890		2123
TP00VO-2DP	AH...	8201-9282		2123
TPX8VO-2DP	AH...	2001-2830		2122
TPX8VO-2DP	AH...	4001-5151		2122
TPX8VO-2DP	AH...	1-854		2122
TPX8VO-2DP	AH...	7101-8154		2122
TPX8VO-2DP	AH...	1001-1918		2123
TPX8VO-2DP	AH...	6001-7086		2123
TPX8VO-2DP	AH...	3001-3890		2123
TPX8VO-2DP	AH...	8201-9282		2123
VO-8P	AH...	2001-2830		56
VO-8P	AH...	1-854		56
VO-8P	AH...	7101-8154		56
VO-8P	AH...	4001-5151		56
VO-8P	AH...	1001-1918		58
VO-8P	AH...	3001-3890		58
VO-8P	AH...	8201-9282		58
VO-8P	AH...	6001-7086		58
VO-8P1	AH...	2001-2830		56
VO-8P1	AH...	1-854		56
VO-8P1	AH...	7101-8154		56
VO-8P1	AH...	4001-5151		56
VO-8P1	AH...	1001-1918		58
VO-8P1	AH...	3001-3890		58
VO-8P1	AH...	8201-9282		58
VO-8P1	AH...	6001-7086		58
TP00VO-8P	AH...	2001-2830		56
TP00VO-8P	AH...	1-854		56
TP00VO-8P	AH...	7101-8154		56
TP00VO-8P	AH...	4001-5151		56
TP00VO-8P	AH...	1001-1918		58
TP00VO-8P	AH...	3001-3890		58
TP00VO-8P	AH...	8201-9282		58
TP00VO-8P	AH...	6001-7086		58
TPX8VO-8P	AH...	2001-2830		56
TPX8VO-8P	AH...	1-854		56
TPX8VO-8P	AH...	7101-8154		56
TPX8VO-8P	AH...	4001-5151		56
TPX8VO-8P	AH...	1001-1918		58
TPX8VO-8P	AH...	3001-3890		58
TPX8VO-8P	AH...	8201-9282		58
TPX8VO-8P	AH...	6001-7086		58
BAI-1D	SP2000.....6P	1234567890	SP2000 6 PINES STOP 0	1582
ORIGINALWIN1	00005-33785	RPE / RPS	10882
ORIGINALWIN1	00005-33785	RPE/RPS Side drilling	10788P

REF	PROFIL	SERIE	FOR:	FILE
TP38HOND-31P	K001-N718	MASTER NEGRA- BLACK	315P
TP38HOND-31P	H...	001-999		315P
TP38HOND-31P	K001-N718	VALET GRIS-GREY	315P
TP38KI-7P	K...	0001-2500	HYUNDAI® / KIA® Laser key	438P
TP38KI-7P	P...	0001-2500	HYUNDAI® / KIA® Laser key	438P
INCE-3	000001-999999		1190P
INCE-4	000001-999999		1190P
INCE-3	.		LATERAL DIMPLE	1192P
LIN-26D	CP0003-CP2620	CP CPLUS	1193P
LIN-26D	CPA00002-CPJ01610	CP + DANALOCK®	1194P
ORIGINALIFAM®5	12345678	SF40M	1040
ORIGINALCISA ®1	P155H00001T- P164H14470U	AP4 P1-9 Cantiere (CA) XN.0337.10	1794P
ORIGINALCISA ®1	P155H00001-P164H32363	AP4-P1-9 Standard XN.0328.10	1795P
ORIGINALPFAFFENHAIN®9	2345678	ABUS ® EC880	1100P
YA-19D	RRM....	1001-2000		7043
ABU-93	1234567	TI12-TI14	452
ABU-93	1234567	E100	452
ABU-86D	00001-30000	E200	729
CI-26	DN.....	00001-30000	ABUS ® E300	489P
CI-26	ZY.....	00001-30000	ABUS ® E300	489P
CI-48	DN.....	00001-30000	ABUS ® E300	489P
CI-48	ZY.....	00001-30000	ABUS ® E300	489P
ORIGINALCISA ®1	1234	RS3 R7 (74) +20° +20° 5P+5P+6P	1252P
ORIGINALDOM ®5	LX725001-LX740000	RS Sigma / Sigma Plus	12751
CI-51	00001-20728	C2000 (5P)	705
CI-51D	AR.....	00001-20728	C2000 (5P)	705
CI-62	0001-2612	C2000 (4P)	705
CI-62D	0001-2612	C2000 (4P)	705
ORIGINALBRICARD ®1	00001AH-84006AH	BRICARD ® SERIAL35 (Perfil Z75)	661P
ORIGINALBRICARD ®1	PM70K00001- PMC4K32363	DUAL XP S2 XN.0341.10	1255P
CI-6D	123456	Locking Line (5P)	455
ORIGINALCISA ®	AR.....	00001-20728	C2000 (5P)	705
ORIGINALBATON	0001-5640	UNITE SERIE 5400 5600	1168P
ORIGINALVIRO ®	CT0001-CT5100	VIRO ® 013 PV (5P)	178
ORIGINALVIRO ®	CW001-CW620	VIRO ® 013 PV (5P)	178
BAJ-2P3	123	BAJAJ ® DISCOVER INDIA	867
ORIGINALVIRO ®	MC.....	00001-56406	039_PV	1160
ORIGINALCLAUTOR®	012345	CLAUTOR®	1256P
ORIGINALCISA ® 1FB	00001-38832	Astral W26 XN009610 (6 + 7 Pins)	11006P
ORIGINALCISA ®1FE	00001-38832	Astral W26 XN009610 (6 + 7 Pins)	11006P
ORIGINALCISA ®1	0000001T-0069547U	RS3 S -20° 20° 4P+4P XN024410 Perfil R5 CA	1077P
ORIGINALCISA ®1	0000001T-0069547U	RS3 S Lateral 5P XN024410 Perfil R5 CA	1079P
DOM ® -B6	012345678	IX6KG	376P

FOR: INCECA®

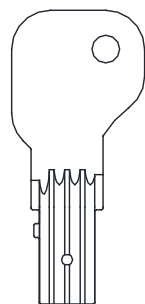

INCECA® Plana

ICC

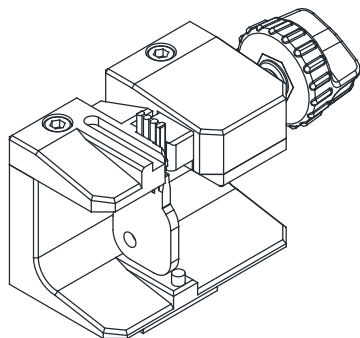

19F



ESPAÑOL

Conforme a las disposiciones legales vigentes relativas a la propiedad industrial, las marcas o nombres comerciales indicados en este catálogo son propiedad exclusiva de los fabricantes de cilindros y cerraduras, así como de los fabricantes de automóviles. Dichas marcas o nombres comerciales se indican en calidad simplemente informativa con el fin de reconocer con rapidez la cerradura a la que corresponden nuestras piezas.

Este catálogo está reservado exclusivamente a profesionales de la reproducción de llaves que utilizan piezas JMA. Los datos referentes a los productos de este catálogo tienen carácter indicativo. Manteniendo siempre las características básicas, nos reservamos el derecho de realizar, sin previo aviso, modificaciones técnicas, estéticas o de otro tipo, por razones de evolución de los productos en cuestión.

FRANÇAIS

Conformément aux dispositions légales en vigueur relatives à la propriété industrielle, les marques ou les dénominations commerciales citées dans ce catalogue sont la propriété exclusive des fabricants de cylindres et de serrures ainsi que des constructeurs de voitures, autres constructeurs, distributeurs et utilisateurs. Ces marques ou dénominations commerciales sont indiquées à titre de simple information afin de connaître rapidement à quelle serrure nos ébauches sont destinées.

Ce catalogue est exclusivement réservé aux professionnels de la reproduction de clés, utilisant des ébauches JMA. Les renseignements sur les produits de ce catalogue sont donnés à titre indicatif. Tout en gardant les caractéristiques de base, nous nous réservons le droit d'apporter, sans préavis, des modifications techniques, esthétiques ou autres, dues à l'évolution des produits en question.

POTUGUESE

Em conformidade com as disposições legais vigentes sobre a propriedade industrial, as marcas ou nomes comerciais indicados neste catálogo são propriedade exclusiva dos fabricantes de cilindros e fechaduras, assim como dos fabricantes de automóveis. Ditas marcas ou nomes comerciais mencionam-se com propósitos meramente informativos, com o fim de reconhecer com rapidez a fechadura a que correspondem as nossas peças.

Este catálogo está reservado exclusivamente a profissionais da reprodução de chaves que utilizam peças JMA. Os dados referentes aos produtos deste catálogo têm carácter meramente indicativo. Mantendo sempre as características básicas, reservamo-nos o direito de realizar, sem prévio aviso, quaisquer modificações técnicas, estéticas ou de outro tipo, resultantes da evolução dos produtos em questão.

ENGLISH

In accordance to current legal dispositions related to industrial property, the brands or commercial names indicated in this catalogue are the exclusive property of the manufacturers of cylinders and locks, as well as the manufacturers of automobiles. These brands or commercial names are used as mere information in order to quickly recognise the lock to which our parts correspond.

This catalogue is exclusively reserved to professional key duplicators that use JMA pieces. The data referring to the products of this catalogue is merely informative. Always maintaining the basic characteristics, we reserve the right to making, without previous notification, technical, aesthetic or other types of modifications, for improvement reasons of the products in question.

DEUTSCH

Gemäß den geltenden gesetzlichen Bestimmungen bezüglich des gewerblichen Eigentums, der Marken oder Handelsnamen, die in diesem Katalog angegeben sind, sind diese ausschließliches Eigentum der Hersteller der Zylinder und Schlösser sowie der Fahrzeughersteller. Diese Marken oder Handelsnamen werden aus rein informativen Gründen angegeben, um die Schlösser, zu denen unsere Teile gehören, schneller zu erkennen.

Dieser Katalog ist ausschließlich für Fachleute auf dem Gebiet der Reproduktion von Schlüsseln gedacht, die Teile von JMA verwenden. Die Daten bezüglich der Produkte dieses Katalogs haben indikativen Charakter. Unter Beibehaltung der grundlegenden Charakteristiken behalten wir uns das Recht vor, ohne Vorankündigung technische, ästhetische oder sonstige Modifikationen aufgrund der Weiterentwicklung der fraglichen Produkte vorzunehmen.

POLSKI

Zgodnie z aktualnymi przepisami prawnymi związanymi z ochroną własności przemysłowej, marki i nazwy handlowe wymienione w tym katalogu są wyłączną własnością producentów wkładek i zamków, oraz producentów samochodów. Zarówno marki jak i nazwy handlowe są wykorzystywane jedynie w celu szybkiego rozpoznania zamka, któremu odpowiadają nasze produkty. Ten katalog jest zarezerwowany wyłącznie dla profesjonalistów kopiowania kluczy korzystających z produktów JMA. Informacje odnoszące się do produktów w katalogu mają charakter orientacyjny. Przy zachowaniu podstawowych parametrów, zastrzegamy sobie prawo, bez uprzedniego powiadomienia, do zmian technicznych, estetycznych lub innych, w celu poprawy produktów.

JMA SPAIN

JMA ALEJANDRO ALTUNA, S.L.U.
Tel +34 943 79 30 00
Fax +34 943 79 72 43
Bidekurtzeta, 6 P.O.Box - Apdo. 70
20500 Arrasate - Mondragón
Gipuzkoa – SPAIN
www.jma.es
jma@jma.es

JMA FRANCE

JMA FRANCE SAS
Tel +33 01 39 22 42 10
Fax +33 01 39 22 42 11
Technoparc
13, rue Edouard Jeanneret
F- 78306 Poissy Cedex
www.jmafrance.fr
service.commercial@jmafrance.fr

JMA UK

SKS LTD
Tel +44 144 229 1400
Fax +44 144 286 3683
Unit 2, Canalside Northbridge Road
Berkhamsted
Herts HP4 1EG
www.jmakeys.co.uk
sales@skkeys.co.uk

JMA PERU

JMA PERU S.A.C.
Tel +51 639 9300
Av. Los Paracas 130,
Urbanización Salamanca,
Distrito Ate, Lima
www.jma-peru.com
info@jma-peru.com

JMA POLSKA

JMA POLSKA Sp. z o.o.
Tel +48 42 635 12 80
Fax +48 42 651 54 63
91- 342 Łódź, ul. Zbąszyńska 3
www.jmapolska.pl
biuro@jmapolska.pl

JMA MAROC

JMA MAROC S.A.R.L.
Tel +0520 150 535
Fax +0520 150 536
83,85 Bd Oued ZIZ, El Oulfa
Casablanca
www.jma.ma
jma@jma.ma

JMA COLOMBIA

IFAM - JMA Colombia, S.A.S.
Tel +57 1 53333246
Fax +57 3203497446
Diagonal 115A - 70B - 45 Local 1
Bogotá
www.jmacolombia.com
info@jmacolombia.com

JMA PORTUGAL

ALTUNA PORTUGAL
COMERCIO DE CHAVES UNIPESSOAL, LDA.
Tel +351 219 947 470
Fax +351 219 947 471
Rua de Goa N°22
2690-356 Santa Iria de Azoia
www.jmaportugal.com
comercial@jmaportugal.com

JMA MEXICO

LLAVES ALTUNA DE MEXICO S.A de C.V
Tel +52 33 3777 1600
Fax +52 33 3777 1609
Av. Aviación No. 5520
Col. San Juan de Ocotán
C.P. 45019 Zapopan, Jalisco
www.jma.com.mx
ventas@jma.com.mx

JMA USA

ALTUNA GROUP USA INC.
Tel +1 817 385 0515
Fax +1 817 385 4850
1513 Greenview Drive
75050 Grand Prairie
Texas
www.jmausa.com
info@jmausa.com

JMA WORLDWIDE

ALTUNA GROUP HEADQUARTERS

Tel +34 943 79 30 00
Fax +34 943 79 72 43
Bidekurtzeta, 6 P.O.Box - Apdo. 70
20500 Arrasate - Mondragón
Gipuzkoa – SPAIN
www.altuna.com



Member Of
Altuna Group