



**EL LIDER EN TECNOLOGÍA**  
THE LEADER IN TECHNOLOGY

**EL LIDER EN CALIDAD**  
THE LEADER IN QUALITY

**EL LIDER EN COMPROMISO  
MEDIOAMBIENTAL**  
THE LEADER IN THE COMMITMENT  
TO THE ENVIRONMENT

**EL LIDER EN SERVICIO**  
THE LEADER IN SERVICE





**A4-A20** **JMA, LA LLAVE DE LA EXCELENCIA**  
JMA, BIKAIN TASUNAREN GILTZA  
JMA, THE KEY TO EXCELLENCE  
JMA, LA CLE DE L'EXCELLENCE  
JMA, DER SCHLÜSSEL ZUR EXZELLENZ

JMA Konpromisoa da  
JMA is Commitment  
JMA, l'engagement  
JMA bedeutet Verpflichtung

**A6-A7** **JMA, el Líder**  
JMA Liderra  
JMA the Leader  
JMA, le Leader  
JMA der Marktführer

**A8-A9** **JMA en el Mundo**  
JMA Munduan  
JMA Worldwide  
JMA dans le Monde  
JMA in der Welt

**A10-A13** **Tipos de Llaves**  
Giltza Motak  
Key Types  
Types de Clés  
Schlüsseltypen

**A14-A15** **Manual de uso**  
Erabilera-eskuliburua  
Manual of use  
Manuel d'utilisation  
Handbuch

**A16-A17** **Descripción y Terminología**  
Deskribapen eta Terminologia  
Description and Terminology  
Description et Terminologie  
Begriffserklärung und Terminologie

**A18-A19** **Símbolos y Nacionalidades**  
Ikur eta Nazionalitateak  
Symbols and Nationalities  
Symboles et Nationalités  
Symbole und Nationalitäten

**A21-A54** **ÍNDICES**  
AURKIBIDEAK  
CONTENTS  
TABLES DES MATIERES  
INHALT

**A21-A42** **Índice General**  
Aurkibide Orokorra  
General Index  
Index Generale  
Gesamtverzeichnis

**A43-A54** **Índice de Marcas**  
Marken Aurkibidea  
Brand Index  
Index Marque  
Hauptmarke

**01-350** **TIPOS DE LLAVES**  
GILTZA MOTAK  
TYPES OF KEYS  
TYPES DE CLÉS  
SCHLÜSSELTYPEN

**01-158** **Llaves Planas para Cerraduras de Cilindro**  
Sarraila Zilindrikotarako Giltza Zapalak  
Cylinder Keys  
Clés pour Cylindres  
Zylinderschlüssel

**159-241** **Llaves para Vehículos**  
Ibilgailuentzako Giltzak  
Keys for Vehicles  
Clés pour Véhicules  
Fahrzeugschlüssel

**242-244** **Llaves de Cierre**  
Ixteko Giltzak  
Snap-lock Keys  
Clés de Bouche d'eau  
Dornschlüssel

**245-255** **Llaves en Cruz**  
Gurutze-Giltzak  
Cruciform Keys  
Clés Cruciformes  
Kreuzschlüssel

**256-276** **Llaves de Gorja Acero Dulce**  
Altzairu Gozozko Gorja-Giltzak  
Mild Steel Bit Keys  
Clés à Gorges en Acier Doux  
Chubbschlüssel aus Weichstahl

**277-337** **Llaves de Gorja Latón**  
Letoizko Gorja Giltzak  
Brass Bit Keys  
Clés à Gorges en Laiton  
Chubbschlüssel aus Messing

**338-340** **Llaves de Gorja Zamak**  
Zamakezko Gorja Giltzak  
Zamak Bit Keys  
Clés à Gorges en Zamak  
Chubbschlüssel aus Zamak

**341-345** **Llaves Artísticas y de Armario Latón**  
Letoizko Giltzak: Armairuetarako eta Artistikoak  
Brass Furniture Keys  
Clés pour Meubles en Laiton  
Möbelschlüssel aus Messing

**346-347** **Llaves Artísticas y de Armario Zamak**  
Zamakezko Giltzak: Armairuetarako eta Artistikoak  
Zamak Furniture Keys  
Clés pour Meubles en Zamak  
Möbelschlüssel aus Zamak

**348-349** **Llaves para Casillas y Ascensores**  
Kutxatila eta Iggogailuentzako Giltzak  
Lift and Mail Box Keys  
Clés pour Ascenseurs et Boîtes à Lettres  
Briefkasten- und Liftschlüssel

**351-424** **GUIA DE MARCAS**  
MARKEN GIDA  
MAIN GUIDE  
GUIDE DES MARQUES  
MARKENINDEX

**351-390** **Automovil-Camioneta**  
Automobila-Kamioneta  
Car-Pick up  
Voiture-Camionnette  
Auto-Kleintransporter

**391-397** **Camión**  
Kamioia  
Trucks  
Camion  
Lkw

**399-418** **Motocicleta**  
Motozikleta  
Motorcycle  
Motocycllette  
Motorrad

**419-424** **Alarma - avión - bicicleta - caravana - tapón de gasolina - motor marino - portaesquí - tractor - excavadora - carretilla elevadora - corta césped**

Alarma - Hegazkina - Bizikleta - Karabana - Gasolina Tapoia - Itsas Motorra - Eskieuskaria - Traktorea - Hondeatzaila - Orga Jasotzailea - Belarra Mozteko Makina

Alarm - Airplan - Bicycle - Caravans - Petrol Cap - Boat Engines - Ski Holder - Tractor - Earth Moving Machine - Forklift - Lawn Mower

Alarme - Avion - Bicyclette - Caravane - Bouchon Reservoir - Moteur de Bateau - Porte Ski - Traktor - Machine por Déplacement de Terre - Clark - Tondeuse

Alarm - Flugzeuge - Fahrräder - Wohnwagen - Tankverschlüsse - Schiffsmotoren - Skiträger Landmaschinen - Baummaschinen - Gabelstapler - Rasenmäher

ESPAÑOL

## NUESTRO ÉXITO ESTÁ BASADO EN EL COMPROMISO DE LAS PERSONAS

Alejandro Altuna S.A. es la sociedad matriz e impulsora de Altuna Group. Fabrica todo tipo de **llaves para cerradura** así como **máquinas duplicadoras**. Sus productos van destinados al mercado **OEM** y a la reposición, en este caso con la marca **JMA**.

Fundada por el Sr. Alejandro Altuna en 1942 arrancó su actividad en Mondragón. En poco tiempo, una nueva generación familiar que apostó por el desarrollo y la inversión impulsó a la empresa a un importante crecimiento que consolidó a la marca **JMA** hacia los 60 como líder indiscutible del país.

Posteriormente, la estrategia de apertura de mercados exteriores apoyada en la internacionalización y siempre basada en un enfoque innovador de los procesos industriales, ha convertido a **ALTUNA GROUP** en el **primer productor de llaves europeo y referente mundial** en este campo.

Actualmente, **15 compañías en 4 continentes** trabajan conjuntamente para el desarrollo y potenciación de la fuerza de nuestra marca JMA, conocida en más de 100 países en todo el mundo.

JMA integra equipos de **personas comprometidas** y motivadas por un proyecto común que nos ha permitido ser el mayor fabricante de llaves de Europa.

EUSKERA

## GURE ARRAKASTA PERTSONEN KONPROMISOAN DATZA

Alejandro Altuna S.A. Altuna Groupen sozietate matrizea eta sustatzaillea da. **Sarrailarako era guztietako giltzak** eta **kopiak egiteko makinak** ekoizten ditu. Bere produktuek **OEM** merkata eta birjarpena dute helburu, eta, kasu horretan, **JMA** markaz merkaturatzen dira.

Enpresa Alejandro Altuna jaunak sortu zuen 1942an, eta Arrasaten hasi zen lanean. Handik gutxira, familiako belaunaldi berriak garapenaren zein inbertsioaren alde egin zuen, eta enpresa bera ikaragarri hazi zen. Hori dela eta, 60ko hamarkadan, **JMA** marka herrialdeko lider eztabaidaezina zen.

Ondoren, kanpoko merkatuetara irekitzeko estrategia nazioarteko bihurtzeko prozesuan oinarritu da, eta, beti-beti, industria-prozesuen ikuspegi berritzailea hartu du kontuan. Horren ondorioz, **ALTUNA GROUP lehen giltzagilea da Europan**, baita arlo horretako **munduko erreferentea** ere.

Gaur egun, **15 konpainiak 4 kontinentetan** lan egiten dute elkarrekin, mundu zabaleko 100etik gora herrialdetan ezaguna den **JMA** markaren indarra garatzeko eta sustatzeko.

JMAko taldeetan **persona konprometituak** eta motibatua daude, eta proiektu bateratua dute. Horri esker, Europako enpresa giltzagile handiena da.

ENGLISH

## OUR SUCCESS IS BASED ON OUR PEOPLE'S COMMITMENT

Alejandro Altuna S.A. is the parent company and driving force behind the Altuna Group. It manufactures all types of **lock-keys and key-cutting machines**. Its products are for the **OEM** and replacement markets, in the latter case with the **JMA** brand.

Set up by Alejandro Altuna in 1942, it started the production in Mondragón (Spain). In a short time, a new generation of the family committed to development and investment saw the company through significant growth which consolidated the **JMA** brand in the 60's as the indisputable leader in Spain.

Later, the strategy of opening up to foreign markets backed by globalisation and always based on an innovative attitude towards industrial processes, turned the **ALTUNA GROUP** into the **largest producer of keys in Europe and a benchmark worldwide** in the field.

Currently **15 companies in four continents** work together to develop the strength of our **JMA** brand, well known in more than 100 countries all over the world.

This successful trail has lead us to become the biggest key producer in Europe based on **our people's commitment**.

# JMA ES COMPROMISO

## JMA IS COMMITMENT



### FRANÇAIS

#### NOTRE SUCCÈS EST FONDÉ SUR L'ENGAGEMENT DES PERSONNES

Alejandro Altuna S.A. est la société-mère qui a donné lieu au Groupe Altuna. Elle fabrique toutes sortes de **clés de serrure et de machines à copier**. Ses produits sont destinés au marché **OEM** et au remplacement, dans ce cas sous la marque **JMA**.

Alejandro Altuna en 1942, elle s'est établie à Mondragón. Très vite, une nouvelle génération familiale a misé sur le développement et grâce aux investissements engagés, l'entreprise a connu une forte croissance qui, dans les années 60, a imposé la marque **JMA** à la tête du secteur.

Par la suite, la stratégie d'ouverture sur les marchés extérieurs et une volonté d'internationalisation toujours sous-tendue par le recours aux procédés industriels les plus novateurs, a fait du **GROUPE ALTUNA** le **premier producteur de clés européen** et un **réfèrent mondial** dans ce domaine.

Actuellement, **15 firmes sur 4 continents** unissent leurs forces pour dynamiser et faire progresser notre marque JMA, connue dans plus de 100 pays du monde entier.

Les équipes JMA sont formées de **personnes motivées et pleinement investies** dans un projet commun qui nous a permis de devenir le plus important fabricant de clés d'Europe.

### DEUTSCH

#### UNSER ERFOLG BASIERT AUF DAS ENGAGEMENT VON MENSCHEN

Alejandro Altuna S.A. ist die Muttergesellschaft, aus der später die Altuna Group hervorging. Sie stellt **Schlüssel** aller Art sowie **Schlüsselkopiermaschinen** her. Ihre Produkte wenden sich an dem OEM- und den Ersatzschlüsselmarkt, in diesem Fall mit der Markenbezeichnung **JMA**.

Das Unternehmen wurde 1942 von Alejandro Altuna gegründet und begann seinen Werdegang in Mondragón. Innerhalb eines nur kurzen Zeitraums sorgte eine neue, auf Entwicklung und Investition setzende Familiengeneration für ein bedeutendes Wachstum und sicherte der Marke **JMA** damit Anfang der 60er Jahre die unbestreitbare Führungsposition im Land.

Später dann hat die auf das Konzept der Internationalisierung und der Innovation der industriellen Prozesse gestützte Strategie der Öffnung gegenüber ausländischen Märkten die **ALTUNA GROUP** zum **führenden europäischen Hersteller von Schlüsseln und einem weltweiten Bezugspunkt** für diesen Sektor werden lassen.

Derzeit arbeiten **15 Unternehmen in 4 Kontinenten gemeinsam**, um die Stärke der in über 100 Ländern der ganzen Welt bekannten Marke JMA zu potenzieren und weiterzuentwickeln.

JMA arbeitet mit Teams **engagierter und motivierter Menschen**, die sich für ein gemeinsames Projekt einsetzen, das es uns möglich gemacht hat, der größte Hersteller von Schlüsseln in Europa zu werden.

**THE KEY TO EXCELLENCE**  
GLOBALLY UNLOCKING MILLIONS OF DOORS DAILY

## ESPAÑOL:

### **LIDER EN TECNOLOGÍA:**

Una apuesta sólida por la calidad y la innovación basada en la automatización y garantía de procesos y soportada por una vocación inversora a largo plazo.

### **LIDER EN CALIDAD:**

En el ámbito de la Calidad Alejandro Altuna S.A. siempre ha sido una empresa líder y pionera en su sector. Nuestra política de calidad se basa en la prevención y planificación, mejora continua, satisfacción del cliente y participación de las personas

Estos valores están impregnados en nuestra empresa desde sus orígenes y han sido, junto con una adecuada política de inversión en instalaciones y maquinaria, el motivo principal de nuestro éxito, que además nos permite asegurar la competitividad de la empresa y con ello el futuro a largo plazo.

Además de la Certificación en Calidad de acuerdo a la ISO 9001, Alejandro Altuna S.A. acoge Sistemas de Gestión de la Calidad homologados por las empresas líderes del sector de automoción y residencial. Actualmente nuestra empresa es reconocida en el mercado como líder en este campo.



### **LIDER EN EL COMPROMISO POR EL MEDIO AMBIENTE:**

En Alejandro Altuna S.A. las buenas prácticas medioambientales son la norma y no la excepción. Nuestro equipo forma parte de un proyecto de empresa respetuoso con el medioambiente y que colabora con el desarrollo sostenible de nuestro entorno.

Alejandro Altuna S.A. fue el primer fabricante mundial de llaves en conseguir en 2000 el certificado ISO 14001 para su Sistema de Gestión. Este Sistema incorpora la política medioambiental, donde se recogen los valores y compromisos de la empresa, así como procedimientos que desarrollan los sistemas de trabajo y garantizan las correctas prácticas medioambientales en todos los ámbitos de la empresa.

### **LIDER EN SERVICIO:**

La realidad de una empresa se demuestra en su capacidad por responder con la máxima celeridad y eficacia a las necesidades y exigencias de los clientes. Se encuentran donde se encuentren. JMA pone a su disposición 5 plantas productivas en localizaciones estratégicas. Además, gracias a su amplia red de filiales y empresas distribuidoras repartidas por todo el mundo, le permite llegar a cualquier cliente, se cual sea su ubicación.



## EUSKERA:

### **LIDERRA TEKNOLOGIAN:**

Kalitatearen eta berrikuntzaren aldeko apustua sendoa da, prozesuen automatizazioan nahiz bermean oinarrituta eta epe luzerako inbertsioa eginda.

### **LIDERRA KALITATEAN:**

Kalitatearen arloan, Alejandro Altuna S.A. sektoreko enpresa liderra eta aitzindaria izan da beti. Hona hemen gure kalitate-politikaren oinarriak: prebentzioa, plangintza, etengabeko hobekuntza, bezeroaren poztasuna eta pertsonen partaidetza.

Balio horiek hasiera-hasieratik ezarri dira gure enpresan, eta, instalazio zein makinatan inbertitzeko politika egokiarekin batera, gure arrakastaren arrazoi nagusia izan dira. Horrez gain, enpresaren lehiakortasuna eta epe luzerako etorkizuna bermatzeko aukera ere eskaini digute.

ISO 9001en arabeko kalitate-ziurtagiria ez ezik, Alejandro Altuna S.A. enpresak ibilgailu-industriako eta bizileku-sektoreko enpresa liderrek homologatutako kalitate-kudeaketarako sistemak ere baditugu. Gaur egun, merkatuaren arabera, gure enpresa liderra da arlo horretan.

### **LIDERRA INGURUMENAREKIKO KONPROMISOAN:**

Alejandro Altuna S.A. enpresan, ingurumen-arloko jarduera egokiak ez dira salbuespena, araua baizik. Gure taldea ingurumena errespetatu eta ingurunearen garapen iraunkorra sustatzen duen enpresa-proiektuaren barruan dago.

2000. urtean, Alejandro Altuna S.A. bere kudeaketa-sistemarako ISO 14001 ziurtagiria lortu zuen lehen giltzagilea izan zen munduan. Ingurumen-politika sistema horren barruan dago kokatuta, eta, bertan, enpresaren balioak zein konpromisoak azaltzen dira, baita lan-sistemak garatu eta enpresako arlo guztietan ingurumen-jarduera egokiak bermatzeko prozedurak ere.

### **LIDERRA ZERBITZUAN:**

Edonon daudela ere, bezeroen premiei eta eskakizunei ahalik eta azkarren eta era eraginkorrean erantzuteko daukan gaitasuna da enpresaren errealitatearen adierazgarri.

JMAk 5 ekoizpen-lantegi ditu leku estrategikoetan. Gainera, bere filialen sarea zabalaren eta banaketa-enpresak mundu zabalean barreiatuta daudenez, edo zein bezerorengana heldu daiteke, edonon dagoela ere.

# JMA, EL LIDER

## JMA, THE LEADER

### ENGLISH:

#### **THE LEADER IN TECHNOLOGY:**

Looking for the latest developments to improve the production processes together with a strong investment policy in all our plants to ensure the company's competitiveness and long-term future.

#### **THE LEADER IN QUALITY:**

As far as Quality is concerned, Alejandro Altuna S.A. has always been a leading, pioneering company in its sector. Our quality policy is based on prevention and planning, continuous improvement, customer satisfaction and people participation.

These values have been impregnated in our company from the start and have been, together with a good investment policy in terms of equipment and machinery, the main reason behind our success, which moreover enables us to ensure the company's competitiveness and long-term future.

In addition to Quality Certification to ISO 9001, Alejandro Altuna S.A. operates Quality Management Systems approved by the leading companies in the automotive and residential sectors. Our company is currently recognised in the market as a leader in this field.

#### **THE LEADER IN THE COMMITMENT TO THE ENVIRONMENT:**

At Alejandro Altuna S.A. best environmental practice is the norm and not the exception. Our team is part of a business project that respects the environment and contributes to the sustainable development of our community.

Alejandro Altuna S.A. was the first key manufacturer in the world to achieve ISO 14001 certification for its management system in 2000. This system incorporates the environmental policy, which includes the company's values and commitments, as well as procedures to set out the work systems and ensure good environmental practice throughout the company.

#### **THE LEADER IN SERVICE:**

The efficiency of a company is shown in its capacity to respond with the maximum speed and effectiveness to the needs and requirements of its customers, wherever they are based.

JMA places at your disposal 5 production plants based in strategic locations. Moreover, with its extensive network of associate and distribution companies located throughout the world, the company can reach any customer, wherever based.

### FRANÇAIS:

#### **LEADER EN TECHNOLOGIE:**

Un pari résolu sur la qualité et l'innovation basée sur l'automatisation et la garantie des process et soutenu par une vocation d'investissement à long terme.

#### **LEADER EN QUALITÉ:**

Dans le domaine de la Qualité, Alejandro Altuna S.A. a toujours été une entreprise pionnière et leader de son secteur. Notre politique de qualité est assise sur la prévention et planification, l'amélioration continue, la satisfaction du client et la participation des personnes. Ces valeurs irriguent notre entreprise depuis sa création. Soutenues par une politique constante d'investissement en installations et machines, elles expliquent, notre succès et, de plus, nous permettent d'assurer la compétitivité de l'entreprise et donc notre futur à long terme.

Bénéficiant de la Certification de Qualité selon la norme ISO 9001, Alejandro Altuna S.A. s'appuie sur des systèmes de gestion de la qualité homologués par les principaux constructeurs, aussi bien automobiles que du bâtiment. Aujourd'hui, notre entreprise est reconnue par le marché comme le leader du secteur.

#### **LEADER EN ENGAGEMENT ENVIRONNEMENTAL:**

Pour Alejandro Altuna S.A., les bonnes pratiques environnementales sont la règle et non l'exception. Notre équipe fait partie d'un projet entrepreneurial respectueux de l'environnement qui collabore au développement durable de notre milieu.

Alejandro Altuna S.A. a été le premier fabricant mondial de clés à obtenir, dès 2000, le certificat ISO 14001 pour son système de gestion. Ce système comporte deux piliers: la politique environnementale, où sont définis les valeurs et les engagements de l'entreprise, et les procédures qui développent les systèmes de travail et qui garantissent les bonnes pratiques environnementales dans tous les domaines d'activité.

#### **LEADER EN SERVICE:**

La réalité d'une entreprise se démontre par sa capacité à répondre le plus promptement et le plus efficacement possible aux besoins et aux exigences des clients. Où qu'ils se trouvent.

JMA place à leur disposition 5 sites de production situés dans des lieux stratégiquement choisis. De plus, grâce à notre vaste réseau de filiales et de distributeurs répartis dans le monde entier, nous pouvons toucher tous nos clients, où qu'ils soient.

### DEUTSCH:

#### **FÜHREND IN TECHNOLOGIE:**

Ein solider Einsatz für die Qualität und die Innovation, der sich auf Automatisierung und Prozesssicherheit sowie eine langfristige Investitionsgrundlage stützt.

#### **FÜHREND IN QUALITÄT:**

Auf dem Gebiet der Qualität war Alejandro Altuna S.A. stets ein führendes und bahnbrechendes Unternehmen des Sektors. Unsere Qualitätspolitik basiert auf Prävention und Planung, ständiger Verbesserung, Kundenzufriedenheit und Einbeziehung der Mitarbeiter.

Diese Werte sind schon seit den Anfängen fester Bestandteile unseres Unternehmens. Gemeinsam mit einer angemessenen Politik der Investition in Anlagen und Maschinenpark waren sie der wichtigste Grund für unseren Erfolg und sichern darüber hinaus die Wettbewerbsfähigkeit des Unternehmens und damit seine langfristige Zukunft.

Neben der Qualitätszertifizierung nach ISO 9001 verfügt Alejandro Altuna S.A. über Qualitätsmanagementsysteme, die von den führenden Automobil- und Wohnungsbauunternehmen zugelassen sind. Derzeit ist unser Unternehmen auf dem Markt für seine führende Position im Bereich Qualität bekannt.

#### **FÜHREND IM UMWELTSCHUTZ:**

Bei Alejandro Altuna S.A. sind gute Umweltpraktiken die Regel, nicht die Ausnahme. Unsere Mitarbeiter sind Teil des Projekts des umweltfreundlichen Unternehmens, das sich für die nachhaltige Entwicklung unserer Umwelt einsetzt. Alejandro Altuna S.A. erhielt im Jahr 2000 als weltweit erster Hersteller von Schlüsseln das Zertifikat ISO 14001 für sein Managementsystem. Dieses System umfasst die Umweltpolitik, die die Werte und Verpflichtungen des Unternehmens sowie die Verfahren für die Herstellungssysteme festlegt, und die korrekten Umweltpraktiken in allen Unternehmensbereichen garantiert.

#### **FÜHREND IM SERVICE:**

Die Realität eines Unternehmens zeigt sich in seiner Fähigkeit, in optimalem Zeitrahmen und mit maximaler Effizienz auf die Bedürfnisse und Anforderungen der Kunden zu reagieren, unabhängig davon, wo diese sich befinden. JMA verfügt über 5 Fertigungsstätten an strategischen Standorten. Dank eines über die ganze Welt ausgedehnten Netzes von Filialen und Vertriebshändlern ist das Unternehmen immer in der Nähe seiner Kunden, egal wo.

**15 COMPAÑÍAS EN 15 PAÍSES  
600 PERSONAS Y  
MÁS DE 550 MILLONES DE LLAVES AL AÑO  
EN MÁS DE 100 PAÍSES EN TODO EL MUNDO.**

**El potencial de JMA en el mundo está cimentado a través de sus plantas productivas y filiales comerciales en Europa, América del Norte y del Sur, Asia y África.  
La internacionalización es una estrategia prioritaria en JMA.**

**JMA MUNDUAN**

15 konpainia 15 herrialdeetan; 600 pertsona eta 550 milioitik gora giltza urtean, mundu zabaleko 100etik gora herrialdeetan.

JMA enpresak ahalmena du munduan, ekoizpen-lantegiak eta filial komertzialak dituelako Europan, Ipar Amerikan, Hego Amerikan, Asian eta Afrikan.  
Izan ere, nazioarteko bihurtzea lehentasunezko estrategia da JMArentzat.

**JMA WORLDWIDE**

15 companies in 15 countries; 600 people and over 550 million keys sold in more than 100 countries all over the 5 continents

JMA's potential worldwide is based on its production plants and commercial subsidiaries in Europe, North and South America, Asia and Africa.  
Globalisation is a priority strategy for JMA.

**JMA DANS LE MONDE**

15 sociétés dans 15 pays ; 600 personnes et plus de 550 millions de clés vendues chaque année dans plus de 100 pays de quatre continents

Le potentiel de JMA dans le monde est solidement ancré dans un réseau de production et de distribution qui couvre l'Europe, les deux Amériques, l'Asie et l'Afrique.  
L'internationalisation est une stratégie prioritaire pour JMA.

**JMA IN DER WELT**

15 Unternehmen in 15 Ländern; 600 Personen und über 550 Millionen Schlüssel pro Jahr in über 100 Ländern der ganzen Welt.

Das Leistungspotenzial von JMA in der ganzen Welt wird durch seine Produktionsstätten und Handelsfilialen in Europa, Nord- und Südamerika, Asien und Afrika konsolidiert. Internationalisierung ist eine vorrangige Strategie von JMA.





# JMA EN EL MUNDO

JMA WORLDWIDE

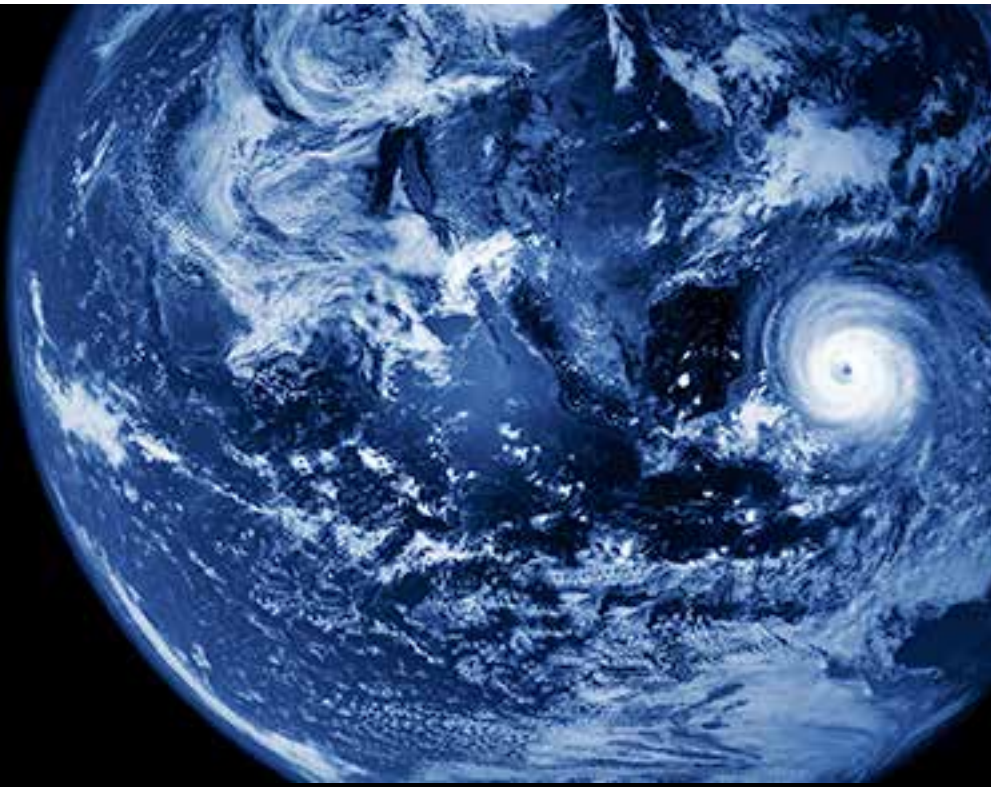

**THE KEY TO EXCELLENCE**  
GLOBALLY UNLOCKING MILLIONS OF DOORS DAILY

**01-158**

**LLAVES PLANAS PARA CERRADURAS DE CILINDRO**

SARRAILA ZILINDRIKOTA-  
RAKO GILTZA ZAPALAK

CYLINDER KEYS

CLÉS POUR CYLINDRES

ZYLINDERSCHLÜSSEL



**159-241**

**LLAVES PARA VEHÍCULOS**

IBILGAILUENTZAKO  
GILTZAK

KEYS FOR VEHICLES

CLÉS POUR VÉHICULES

FAHRZEUGSCHLÜSSEL



**242-244**

**LLAVES DE CIERRE**

IXTEKO GILTZAK

SNAP-LOCK KEYS

CLÉS DE BOUCHE D'EAU

DORNSCHLÜSSEL



**245-255**

**LLAVES EN CRUZ**

GURUTZE-GILTZAK

CRUCIFORM KEYS

CLÉS CRUCIFORMES

KREUZSCHLÜSSEL



**256-276**

**LLAVES DE GORJA ACERO DULCE**

ALTZAIRU GOZOZKO  
GORJA-GILTZAK

MILD STEEL BIT KEYS

CLÉS À GORGES EN ACIER DOUX

CHUBBSCHLÜSSEL  
AUS WEICHSTAHL



# TIPOS DE LLAVES

## KEY TYPES

**277-337**

### LLAVES DE GORJA LATÓN

LETOIZKO GORJA GILTZAK

BRASS BIT KEYS

CLÉS À GORGES EN  
LAITON

CHUBBSCHLÜSSEL AUS  
MESSING

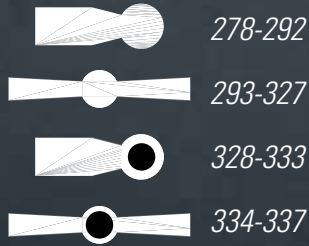

**338-340**

### LLAVES DE GORJA ZAMAK

ZAMAKEZKO GORJA  
GILTZAK

ZAMAK BIT KEYS

CLÉS À GORGES EN ZAMAK

CHUBBSCHLÜSSEL AUS  
ZAMAK



**341-345**

### LLAVES ARTÍSTICAS Y DE ARMARIO LATÓN

LETOIZKO GILTZAK:  
ARMAIRUETARAKO  
ETA ARTISTIKOAK

BRASS FURNITURE KEYS

CLÉS POUR MEUBLES EN LAITON

MÖBELSCHLÜSSEL  
AUS MESSING



**346-347**

### LLAVES ARTÍSTICAS Y DE ARMARIO ZAMAK

ZAMAKEZKO GILTZAK:  
ARMAIRUETARAKO  
ETA ARTISTIKOAK

ZAMAK FURNITURE KEYS

CLÉS POUR MEUBLES EN ZAMAK

MÖBELSCHLÜSSEL AUS ZAMAK



**348-349**

### LLAVES PARA CASILLAS Y ASCENSORES

KUTXATILA ETA  
IGOGAILUENTZAKO GILTZAK

LIFT AND MAIL BOX KEYS

CLÉS POUR ASCENSEURS ET  
BOITES A LETTRES

BRIEFKASTEN- UND  
LIFTSSCHLÜSSEL



**THE KEY TO EXCELLENCE**  
GLOBALLY UNLOCKING MILLIONS OF DOORS DAILY

## GRABADAS

GILTZA GRABATUAK  
COINED KEYS  
CLÉS FRAPÉES  
PRÄGESCHLÜSSEL

*Consultar Referencias  
Erreferentziak Kontsultatu  
Check References  
Voir Références  
Referenzen Konsultieren*



## ALUMINIO

*Consultar Referencias  
Erreferentziak Kontsultatu  
Check References  
Voir Références  
Referenzen prüfen*



## WIND-COLOR

*Consultar Referencias  
Erreferentziak Kontsultatu  
Check References  
Voir Références  
Referenzen prüfen*



## COLORMATIC

*Consultar Referencias  
Erreferentziak Kontsultatu  
Check References  
Voir Références  
Referenzen prüfen*



# LLAVES ESPECIALES

SPECIAL KEYS

## FASHION

*Consultar Referencias  
Erreferentziak Kontsultatu  
Check References  
Voir Références  
Referenzen prüfen*



## PET COLLECTION

*Consultar Referencias  
Erreferentziak Kontsultatu  
Check References  
Voir Références  
Referenzen prüfen*



## STYLCOLOR

*Consultar Referencias  
Erreferentziak Kontsultatu  
Check References  
Voir Références  
Referenzen prüfen*



## ESPAÑOL

### AVISO LEGAL - CATÁLOGO GENERAL C.11

Las llaves que aparecen en este catálogo son piezas JMA fabricadas por Alejandro ALTUNA S.A. o un subcontratista de éste. Están diseñadas para cilindros y cerraduras de los fabricantes cuyas marcas se indican en este catálogo.

Conforme a las disposiciones legales vigentes relativas a la propiedad industrial, las marcas o nombres comerciales indicados en este catálogo son propiedad exclusiva de los fabricantes de cilindros y cerraduras, así como de los fabricantes de automóviles, otros constructores, distribuidores y usuarios.

Dichas marcas o nombres comerciales se indican en calidad simplemente informativa con el fin de reco-

nocer con rapidez la cerradura a la que corresponden nuestras piezas.

Este catálogo está reservado exclusivamente a profesionales de la reproducción de llaves que utilizan piezas JMA.

Los datos referentes a los productos de este catálogo tienen carácter indicativo. Manteniendo siempre las características básicas, nos reservamos el derecho de realizar, sin previo aviso, modificaciones técnicas, estéticas o de otro tipo, por razones de evolución de los productos en cuestión.

Algunos modelos que están en este nuevo catálogo podrán recibirlos tanto con la marca y la referencia JMA como con otra marca del grupo ALTUNA.

## EUSKERA

### LEGE-OHARRA - KATALOGO OROKORRA C.11

Katalogo honetan ageri diren giltzak Alejandro ALTUNA SA enpresak edo honek kontratatutako beste enpresa batek egindako JMA piezak dira. Katalogoan zehazten diren marken fabrikatzaileen zilindro eta sarrailetarako diseinatuta daude.

Jabetza industrialari buruz indarrean dauden lege-xedape-nekin bat etorri, katalogo honetan zehaztutako merkataritza-markak edo izenak zilindro eta sarraileen fabrikatzaileen nahiz ibilgailuen fabrikatzaileen eta beste erakitzailen, banatzaile eta erabiltzaile batzuen jabetza eskusibokoak dira.

Merkataritza-marka edo izen horiek zehaztasun gehiago emateko adierazten dira, gure piezak zein sarraileari dagozkion berehala ikusi ahal izateko.

Katalogo hau giltzen kopiari egiteko JMA piezak erabiltzen dituzten profesionalentzako da soilik.

Katalogo honetako produktuei buruzko datuek izaera adierazgarria dute. Oinarriko ezaugarriak gordez, produktuen bilakaeraren ondoriozko aldaketak teknikoak, estetikoak edo bestelakoak egiteko eskubidea dugu, aurretik horren berri eman beharrik gabe.

Katalogo berri honetan dauden eredueta batak JMA marka eta erreferentziarekin nahiz ALTUNA taldeko beste marka batekin jaso ahal izango dira.

## ENGLISH

### LEGAL WARNING - GENERAL CATALOGUE C.11

The keys that appear in this catalogue are JMA parts manufactured by Alejandro ALTUNA S.A. or one of its subcontractors. They are designed for cylinders and locks made by the manufacturers whose trademarks are indicated in this catalogue.

In accordance with legal requirements relating to industrial property rights, the trademarks or trade names indicated in this catalogue are the exclusive property of the manufacturers of the cylinders and locks, as well as automobile manufacturers, other constructors, distributors and users.

The aforementioned trademarks or trade names are indicated simply for information purposes so that the lock to which our parts correspond can be recognised quickly and easily. This catalogue is for the exclusive use of professional key copiers who use JMA parts.

Data referring to the products in this catalogue are indicative in nature. Although the basic characteristics are maintained at all times, we reserve the right to make, without previous notice, any technical, aesthetic or other types of changes involved in the development of the products in question.

Some of the keys in this new catalogue could be received either with the JMA reference and trademark or with another trademark from the ALTUNA group.

## FRANÇAIS

### MENTIONS LEGALES - CATALOGUE GENERALE C.11

Les ébauches de clés reportées sur ce catalogue sont des ébauches JMA fabriquées par Alejandro ALTUNA S.A. ou un de ses sous-traitants Elles sont destinées aux cylindres et serrures des fabricants dont les marques sont indiquées dans ce catalogue.

Conformément aux dispositions légales en vigueur relatives à la propriété industrielle, les marques ou les dénominations commerciales citées dans ce catalogue sont la propriété exclusive des fabricants de cylindres et de serrures ainsi que des constructeurs de voitures, autres constructeurs, distributeurs et utilisateurs.

Ces marques ou dénominations commerciales sont indiquées à titre de simple information afin de connaître rapidement à quelle serrure nos ébauches sont destinées.

Ce catalogue est exclusivement réservé aux professionnels de la reproduction de clés, utilisant des ébauches JMA.

Les renseignements sur les produits de ce catalogue sont donnés à titre indicatif. Tout en gardant les caractéristiques de base, nous nous réservons le droit d'apporter, sans préavis, des modifications techniques, esthétiques ou autres, dues à l'évolution des produits en question.

Des ébauches de ce catalogue pourront être livrées soit avec la marque et référence JMA soit avec une autre marque du groupe ALTUNA.

## DEUTSCH

### IMPRESSUM- GESAMTKATALOG C.11

Die in dem vorliegenden Katalog aufgeführten Schlüssel sind JMA-Teile, die von der Firma Alejandro ALTUNA, S.A., einem Zulieferanten von JMA, hergestellt werden. Sie sind für Zylinder und Schlösser derjenigen Hersteller entwickelt worden, deren Marken in diesem Katalog aufgeführt sind.

In Übereinstimmung mit den geltenden gesetzlichen Vorschriften bezüglich des gewerblichen Eigentums sind die im vorliegenden Katalog aufgeführten Marken und Firmennamen ausschließliches Eigentum der Zylinder- und Schloßhersteller, sowie der Automobilhersteller und anderer Konstrukteure, Vertrieber und Benutzer.

Diese Marken und Firmennamen werden nur zu Informationszwecken aufgeführt, mit dem Ziel, auf schnelle Weise zu erkennen, zu welchem Schloß unsere Teile gehören.

Dieser Katalog ist ausschließlich für Fachleute des Bereichs der Schlüsselreproduktion gedacht, die JMA-Teile verwenden.

Die Daten bezüglich der Produkte des vorliegenden Katalogs haben informativen Charakter. Bei Aufrechterhaltung der grundlegenden Eigenschaften behalten wir uns das Recht vor, aus Gründen der Entwicklung der entsprechenden Produkte und ohne Vorankündigung technische, ästhetische oder andere Änderungen vorzunehmen. Einige Modelle des neuen Katalogs können Sie sowohl mit der Marke und der Bezeichnung JMA erhalten, als auch mit jeder anderen Marke der Gruppe ALTUNA.

**THE KEY TO EXCELLENCE**  
GLOBALLY UNLOCKING MILLIONS OF DOORS DAILY



# MANUAL DE USO

## MANUAL OF USE

### ESPAÑOL

#### MANUAL DE USO

Todas las llaves del catálogo están en escala 1:1; tanto la silueta como el perfil, para hacer una búsqueda más fácil y precisa. Pasos a seguir para la identificación de la llave:

**1. Identificación de la silueta:** Confirmar que la llave que busca coincide con las dimensiones de la llave catálogo. Ver Fig. 1

#### 2. Identificación del perfil:

**2.1** Ver si el perfil de la llave y el perfil del catálogo forman una misma imagen. Ver Fig. 2.1

**2.2** Cerciorar que el perfil del catálogo tiene la misma forma y dimensión, colocando la llave física sobre la imagen del catálogo. Ver Fig. 2.2

### EUSKERA

#### ERABILERA-ESKULIBURUA:

Katalogoko giltza guztiak 1:1 eskalan agertzen dira; hala silueta nola profila, bilaketa errazagoa eta zehatzagoa izan dadin. Giltza identifikatzeko urratsak:

**1. Silueta identifikatzea:** Bilatzen den giltzak katalogoan agertzen den giltzaren dimentsio bera duela baiezatu. Ikus 1. irudia.

#### 2. Profila identifikatzea:

**2.1** Giltzaren profilak eta katalogoko profilak irudi bera osatzen duten ikusi. Ikus 2.1. irudia.

**2.2** Katalogoko profilak forma eta dimentsio bera duela ziurtatzea, giltza fisikoa katalogoko irudiaren gainean jarri. Ikus 2.2. irudia.

### ENGLISH

#### MANUAL OF USE

All the keys in this catalogue are 1:1 scale; both the silhouette outline and profile, to facilitate a precise search. Steps to follow for identifying the key:

**1. Identification of the silhouette:** Confirm that the key you want matches with the dimensions of the key in the catalogue. See Fig. 1

#### 2. Identification of the profile:

**2.1** Check to see if the profile of the original key and the profile in the catalogue have a similar shape. See Fig. 2

**2.2** Make sure the profile of the catalogue has the same shape and dimension, by placing the physical key over the image in the catalogue. See Fig. 2.2

### FRANÇAIS

#### MANUEL D'UTILISATION

Toutes les clés du catalogue sont à l'échelle 1:1; aussi bien la silhouette que le profil, afin de permettre une recherche plus simple et précise. Étapes à suivre pour l'identification de la clé :

**1. Identification de la silhouette :** Confirmer que la clé recherchée correspond aux dimensions de la clé du catalogue. Voir Fig.1

#### 2. Identification du profil :

**2.1.** Voir si le profil de la clé correspond au profil du catalogue. Voir Fig.2.1

**2.2.** S'assurer que le profil du catalogue a la même forme et les mêmes dimensions, en plaçant la clé physique sur l'image du catalogue. Voir Fig.2.2

### DEUTSCH

#### HANDBUCH

Alle Schlüssel im Katalog sind im Maßstab 1:1 dargestellt, sowohl als Silhouette als auch im Profil, um die Suche leichter und genauer zu machen. Zu befolgende Schritte für die Identifizierung des Schlüssels:

**1. Identifizierung der Silhouette:** Bestätigung, dass der gesuchte Schlüssel mit dem Abmessungen im Katalog übereinstimmt. Siehe Abb. 1

#### 2. Identifizierung des Profils:

**2.1.** Prüfen, ob das Profil des Schlüssels und das im Katalog gezeigte Profil übereinstimmen. Siehe Abb. 2.1

**2.2.** Vergewissern, dass das Profil im Katalog die gleiche Form und Größe hat, indem man den tatsächlichen Schlüssel auf das Katalogbild legt. Siehe Abb. 2.2

### IDENTIFICACIÓN DE LA LLAVE

#### IDENTIFICACIÓN DE LA LLAVE

#### 1. Identificación de la Silueta

##### Identificación de la Silueta

# 1



#### 2. Identificación del perfil

##### Identificación del perfil

# 2.1



# 2.2

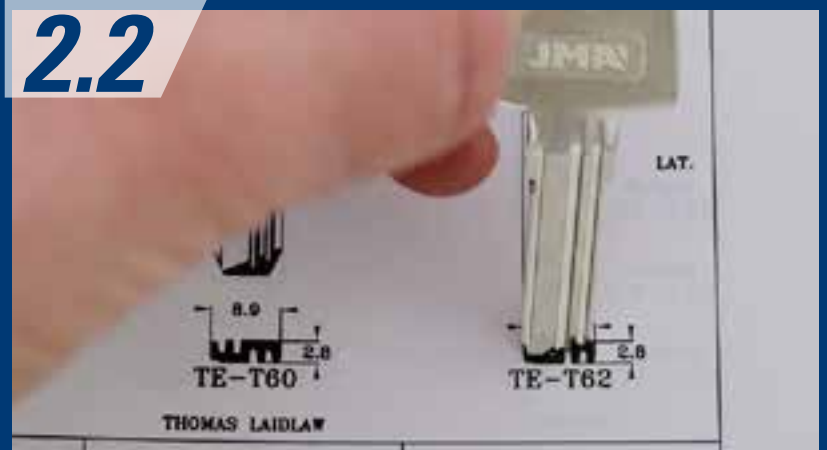

**ESPAÑOL**

- 1 MARCA PRINCIPAL
- 2 CABEZA
- 3 CUELLO
- 4 TOPE
- 5 PALETÓN
- 6 PUNTA
- 7 UTILIZACIÓN
- 8 NOMENCLATURA DE PERFIL ORIGINAL
- 9 PERFIL IZQUIERDO
- 10 PERFIL DERECHO
- 11 REFERENCIA
- 12 MARCAS SECUNDARIAS
- 13 SERIES
- 14 MARCA PRINCIPAL
- 15 MARCAS SECUNDARIAS DE LA PRINCIPAL (ABSA)

**1 ABSA**

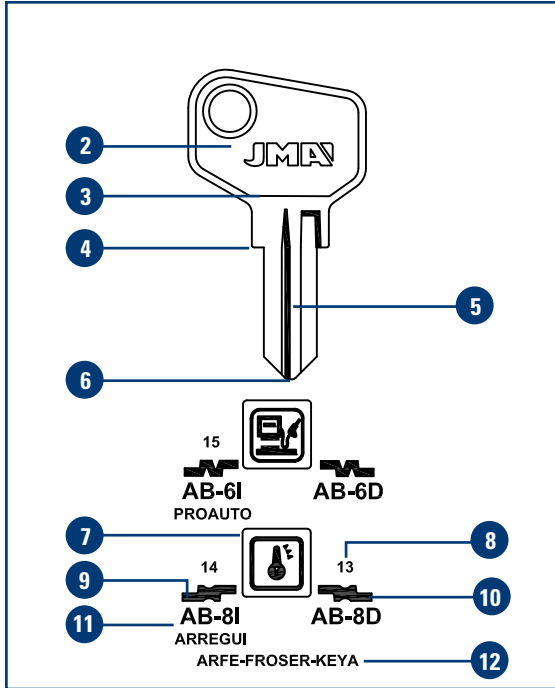

**1 VACHETTE**

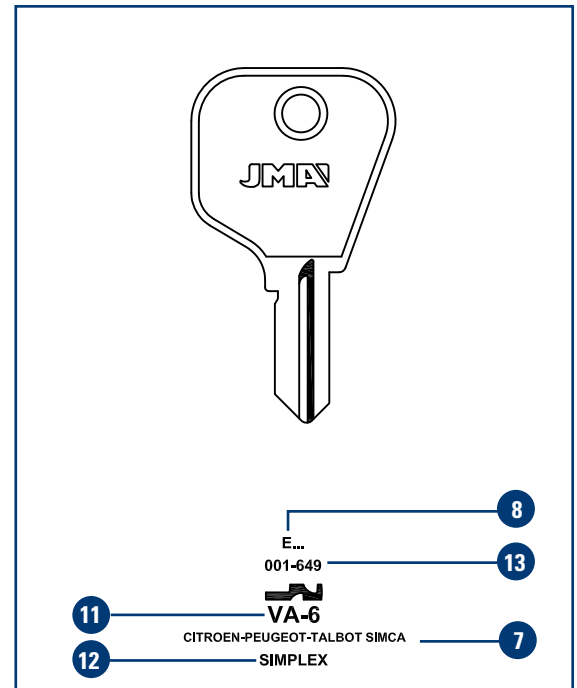

| EUSKERA  | ENGLISH                                    | FRANÇAIS                                       | DEUTSCH                               |
|--|--|--|---------------------------------------|
| 1 MARKA NAGUSIA                                    | 1 MAIN BRAND                               | 1 MARQUE PRINCIPALE                            | 1 HAUPTPRÄGUNG                        |
| 2 BURUA  | 2 HEAD                                     | 2 TÊTE   | 2 KOPF                                |
| 3 LEPOA  | 3 NECK                                     | 3 COU  | 3 HALS                                |
| 4 TOPEA  | 4 SHOULDER                                 | 4 ARRÊT  | 4 ANSCHLAG                            |
| 5 BELARRIA   | 5 BLADE                                    | 5 CANON  | 5 SCHAFT                              |
| 6 PUNTA  | 6 TIP                                      | 6 POINTE                                       | 6 SPITZE                              |
| 7 ERABILERA  | 7 USE                                      | 7 UTILISATION                                  | 7 VERWENDUNG                          |
| 8 JATORRIZKO PROFILAREN IZENDEGIA                  | 8 ORIGINAL PROFILE                         | 8 PROFIL ORIGINAL                              | 8 ORIGINALPROFIL                      |
| 9 EZKERREKO PROFILA                                | 9 LEFT PROFILE                             | 9 PROFIL GAUCHE                                | 9 LINKSPROFIL                         |
| 10 ESKUINEKO PROFILA                               | 10 RIGHT PROFILE                           | 10 PROFIL DROIT                                | 10 RECHTSPROFIL                       |
| 11 ERREFERENTZIA                                   | 11 REFERENCE                               | 11 RÉFÉRENCE                                   | 11 BEZEICHNUNG                        |
| 12 BIGARREN MAILAKO MARKAK                         | 12 SECONDARY BRAND                         | 12 MARQUE SECONDAIRE                           | 12 2. PRÄGUNG                         |
| 13 SERIEAK   | 13 SERIES                                  | 13 CODE  | 13 SERIE                              |
| 14 MARCA NAGUSIA ETA JATORRIZKOA                   | 14 MAIN BRAND AND NATIONALITY              | 14 MARQUE PRINCIPALE ET NATIONALITÉ            | 14 HAUPTPRÄGUNG UND NATIONALITÄT      |
| 15 MARKA NAGUSIAREN BIGARREN MAILAKO MARKAK (ABSA) | 15 SECONDARY BRANDS OF THE MAIN ONE (ABSA) | 15 MARQUES SECONDAIRES DE LA PRINCIPALE (ABSA) | 15 2. PRÄGUNG FÜR HAUPTPRÄGUNG (ABSA) |



# DESCRIPCIÓN Y TERMINOLOGÍA

## KEY DESCRIPTION AND TERMINOLOGY

### ESPAÑOL

- 1 CABEZA
- 2 CUELLO
- 3 DIÁMETRO DE LA CAÑA
- 4 CAÑA
- 5 LONGITUD A
- 6 PALETON
- 7 PERFIL MACHO
- 8 REFERENCIA
- 9 MARCA ORIGINAL
- 10 PERFIL HEMBRA

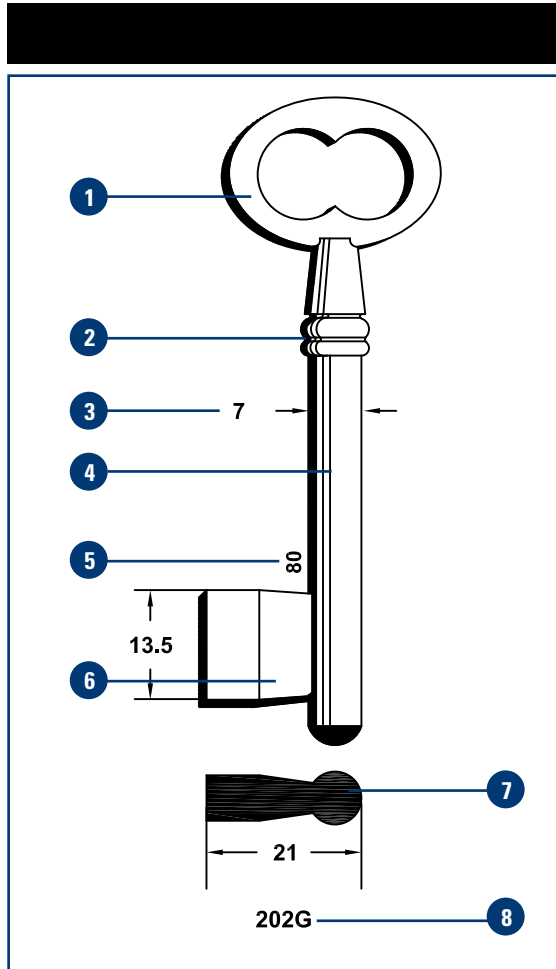

### 9 — ORENGO

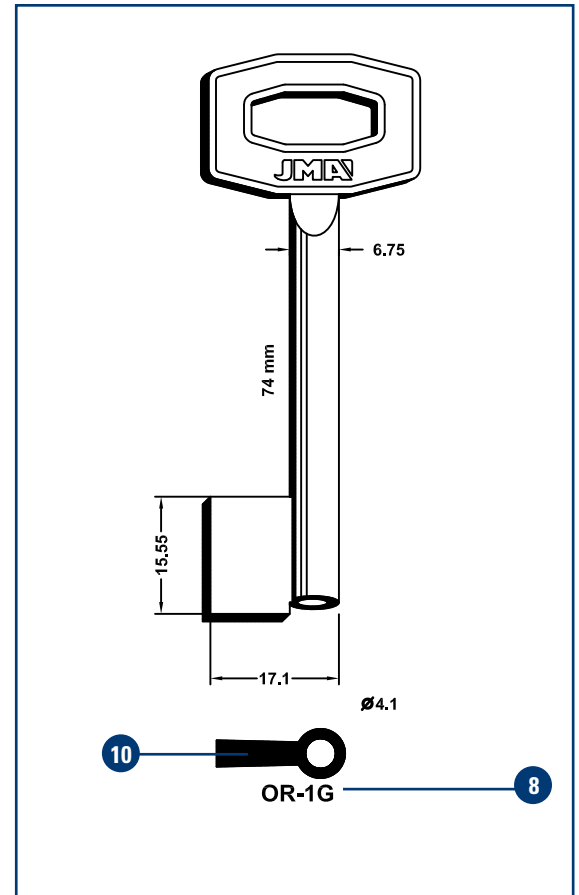

| EUSKERA                 | ENGLISH             | FRANÇAIS               | DEUTSCH                |
|-------------------------|---------------------|------------------------|------------------------|
| 1 BURUA                 | 1 HEAD              | 1 TÊTE                 | 1 KOPF                 |
| 2 LEPOA                 | 2 NECK              | 2 COU                  | 2 HALS                 |
| 3 ZIRIAREN<br>DIAMETROA | 3 SHANK<br>DIAMETER | 3 DIAMETRE DU<br>CANON | 3 HALM-<br>DURCHMESSER |
| 4 ZIRIA                 | 4 SHANK             | 4 CANON                | 4 HALM                 |
| 5 A LUZERA              | 5 LENGTH A          | 5 LONGUEUR A           | 5 LÄNGE A              |
| 6 BELARRIA              | 6 BIT               | 6 PANNETON             | 6 BART                 |
| 7 PROFIL ARRA           | 7 PIN BIT PROFILE   | 7 PROFIL MALE          | 7 SCHWEIFUNG           |
| 8 ERREFERENTZIA         | 8 REFERENCE         | 8 RÉFÉRENCE            | 8 BEZEICHNUNG          |
| 9 JATORRIZKO<br>MARKA   | 9 ORIGINAL BRAND    | 9 MARQUE<br>ORIGINALE  | 9 ORIGINAL-<br>PRÄGUNG |
| 10 PROFIL EMEA          | 10 PIPE BIT PROFILE | 10 PROFIL FEMELLE      | 10 GEBOHRT             |

**ALP.**

**Llave fabricada en alpaca**

Alpakaz egindako giltza  
Key available in nickel silver  
Clé fabriquée en maillechort  
Schlüssel auch in Neusilber lieferbar

**LAT.**

**Llave disponible también en latón**

Giltza, letoizkoa ere eskuragarria  
Key also available in brass  
Clé aussi disponible en laiton  
Schlüssel auch in Messing lieferbar

**COL.**

**Llave disponible también con cabeza de plástico en colores**

Giltza hau koloretako plastikozko buruarekin ere eskuragarria

Key also available with coloured plastic head

Clé aussi disponible avec tête plastifiée en couleurs

Schlüssel auch mit farbigem Plastikkopf lieferbar

**ALU.**

**Llave disponible también en aluminio**

Giltza, aluminioan ere eskuragarria  
Key also available in aluminium  
Clé aussi disponible en aluminium  
Schlüssel auch in Aluminium lieferbar

**ZAM.**

**Llave fabricada solamente en zamak**

Zamakez soilik egindako giltza  
Key only available in zamak  
Clé aussi disponible en zamak  
Schlüssel nur aus Zamak lieferbar



35

**Llave de utilizacion en candados**

Giltzarrapoetan erabiltzeko giltzak  
Key for padlocks  
Clé pour cadenas  
Schlüssel für Hangschlösser



**Llave de utilización en cerraduras auxiliar**

Sarraila osagarrietan erabiltzeko giltzak  
Key for cam locks  
Clé pour petite serrurie  
Schlüssel für Hebelschlösser



**Llaves para motocicletas**

Motozikleta giltzak  
Key for motorcycles  
Clé pour motocyclettes  
Schlüssel für Motorräder



**Llave para tapón de gasolina**

Gasolina-tapoietarako giltza  
Key for fuel cap  
Clé pour bouchon d'essence  
Schlüssel für Tankdeckel



**Llave para camión**

Kamioiko giltza  
Key for lorries  
Clé pour camion  
Schlüssel für Lastkraftwagen



**Alarma**

Alarma  
Alarm  
Alarme  
Alarm



**Llaves gorja con acabado en color natural**

Gorja giltzak berezko kolorezko akaberarekin  
Bit key blank with natural colour finishing  
Clé à gorges avec finition en couleur naturel  
Chubbsschlüssel in naturfarben Ausführung



**Llaves gorja con acabado en negro antiguo**

Gorja giltza, beltz zaharkitu akaberarekin  
Bit key blank with old black finishing  
Clé à gorges avec finition en vieux noir  
Chubbsschlüssel in altschwarzer Ausführung

**NACIONALIDAD** - NAZIONALITATEA - NATIONALITY - NACIONALITÉ - NATIONALITÄT

AUSTRIA  
AUSTRALIA  
BELGIUM  
BRAZIL  
CANADA  
SWITZERLAND  
GERMANY  
DENMARK

**A**  
**AUS**  
**B**  
**BR**  
**CDN**  
**CH**  
**D**  
**DK**

ALGERIA  
SPAIN  
ESLOVAKIA  
EGYPT  
FRANCE  
GREAT BRITAIN  
GREECE  
HUNGARY

**DZ**  
**E**  
**ES**  
**ET**  
**F**  
**GB**  
**GR**  
**H**

HONG KONG  
CROATIA  
ITALY  
ISRAEL  
INDIA  
EIRE  
JAPAN  
KOREA

**HK**  
**HR**  
**I**  
**IL**  
**IND**  
**IRL**  
**J**  
**K**

# SÍMBOLOS

## SYMBOLS

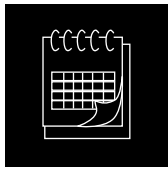

### **Calendario**

Egutegia  
Calendar  
Calendrier  
Kalender



### **Contacto auto**

Autoko kontaktua  
Engine ignition  
Contact auto  
Zündschloss Pkw

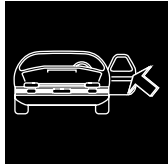

### **Puerta**

Atea  
Door lock  
Portière  
Türe

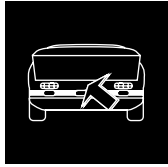

### **Maletero/Puerta trasera**

Maletategia/Atzeko atea  
Boot/Hatchback  
Coffre/Portière postérieure  
Kofferraum/Hecktür



### **Tapón de gasolina**

Gasolina-tapoia  
Petrol cap  
Bouchon réservoir  
Benzintankverschluss

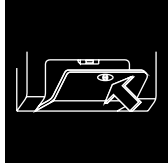

### **Guantera**

Eskularru-kutxa  
Drawer  
Tiroir  
Schublade

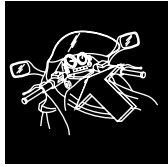

### **Contacto moto**

Moto-kontaktua  
Motorbike ignition  
Contact moto  
Zündschloss Motorrad

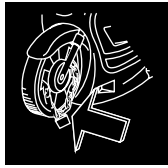

### **Bloqueo moto**

Moto-blokeoa  
Motorbike disc lock  
Bloquage moto  
Bremsenschloss Motorrad

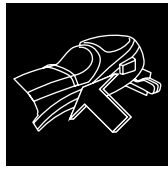

### **Sillin**

Zela  
Cycle seat  
Selle  
Sattel

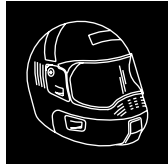

### **Casco**

Kaskoa  
Helmet  
Casque  
Helm



### **Automovil / camioneta**

Automobila / kamioneta  
Car / Pick-up trucks  
Voiture / Camionnette  
Auto / Kleintransporter

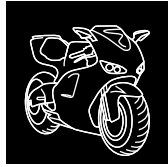

### **Motocicleta**

Motozikleta  
Motorcycle  
Motocyclette  
Motorrad



### **Camión**

Kamioia  
Trucks  
Camion  
Lkw

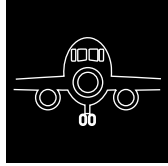

### **Avión**

Hegazkina  
Aeroplane  
Avion  
Flugzeuge

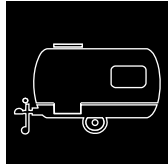

### **Caravana**

Karabana  
Caravans  
Caravane  
Wohnwagen

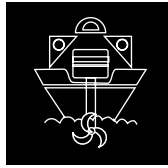

### **Motor marino**

Itsas motorra  
Boat engines  
Moteur de bateau  
Schiffsmotoren

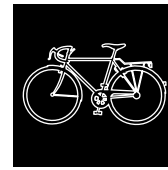

### **Bicicleta**

Bizikleta  
Bicycle  
Bicyclette  
Fahrräder

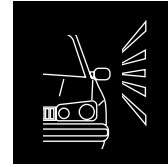

### **Alarma**

Alarma  
Alarm  
Alarme  
Alarm

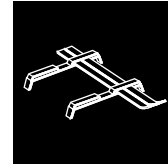

### **Portaesquis**

Eski-euskarria  
Ski holder  
Porte ski  
Skiträger

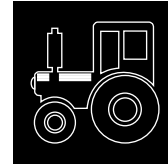

### **Tractor**

Traktorea  
Tractor  
Traktor  
Landmaschinen

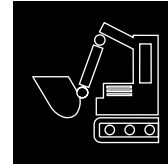

### **Escavadora**

Hondeatzailea  
Earth moving machine  
Machine déplacement de terre  
Baumaschinen



### **Carretilla elevadora**

Orga jasotzailea  
Forklift  
Clark  
Gabelstapler

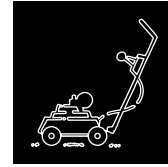

### **Corta cesped**

Belarra mozteko makina  
Lawn-mower  
Tondeuse  
Rasenmäher



### **Alarma - llave**

Alarma - giltza  
Alarm - key  
Alarme - clef  
Alarm - Schlüssel

KUWAIT  
MEXICO  
NORWAY  
THE NETHERLANDS  
PORTUGAL  
PERU  
POLAND  
ARGENTINA

**KW**  
**MEX**  
**N**  
**NL**  
**P**  
**PE**  
**PL**  
**RA**

TAIWAN  
CHILE  
CHEKIA  
RUMANIA  
SWEDEN  
FINLAND  
SLOVENIA  
RUSIA

**RC**  
**RCH**  
**RCZ**  
**RU**  
**S**  
**SF**  
**SLO**  
**RJ**

CHINA  
TUNISIA  
UNITED STATES OF AMERICA  
YUGOSLAVIA  
VENEZUELA  
ZAMBIA

**TJ**  
**TN**  
**USA**  
**YU**  
**YV**  
**Z**



# ÍNDICE DE GENERAL

AURKIBIDEA OROKORRA

GENERAL INDEX

INDEX GENERALE

GESAMTVERZEICHNIS



**THE KEY TO EXCELLENCE**  
GLOBALLY UNLOCKING MILLIONS OF DOORS DAILY

| REF.     | PAG.    |
|----------|---------|
| 1G       | 278     |
| 2G       | 278     |
| 3G       | 278     |
| 3M-1D    | 1       |
| 4G       | 278     |
| 5G       | 278     |
| 5-L      | 135     |
| 6-C      | 146     |
| 6G       | 278     |
| 6-L      | 146     |
| 7G       | 278     |
| 7-S      | 118-349 |
| 8G       | 278     |
| 8M-1D    | 105     |
| 11G      | 279     |
| 12G      | 279     |
| 13G      | 279     |
| 14G      | 279     |
| 15-D     | 223     |
| 15G      | 279     |
| 15-I     | 223     |
| 16-D     | 224     |
| 16G      | 279     |
| 16-I     | 224     |
| 17G      | 279     |
| 19G      | 280     |
| 21G      | 280     |
| 23G      | 280     |
| 24G      | 280     |
| 25G      | 280     |
| 26-M     | 112-349 |
| 28-D     | 162     |
| 35-D     | 146     |
| 35-I     | 146     |
| 38-D     | 146     |
| 38-I     | 146     |
| 41-4-4   | 209     |
| 45-1     | 1       |
| 45-1D    | 1       |
| 45-2     | 1       |
| 45-2D    | 1       |
| 48-D     | 185     |
| 48-I     | 185     |
| 51G      | 328     |
| 52G      | 328     |
| 52GPC    | 328     |
| 53G      | 328     |
| 54G      | 328     |
| 55G      | 328     |
| 56G      | 328     |
| 57G      | 328     |
| 66G      | 329     |
| 68G      | 329     |
| 72G      | 329     |
| 73G      | 329     |
| 74G      | 267     |
| 101G     | 337     |
| 126H-60G | 283     |
| 126N-60G | 283     |

| REF.      | PAG. |
|-----------|------|
| 126PP-60G | 283  |
| 200G      | 257  |
| 201G      | 257  |
| 202G      | 257  |
| 203G      | 257  |
| 204G      | 257  |
| 205G      | 257  |
| 206G      | 257  |
| 207G      | 258  |
| 208G      | 258  |
| 209G      | 258  |
| 210G      | 258  |
| 211G      | 258  |
| 212G      | 259  |
| 213G      | 259  |
| 214G      | 259  |
| 215G      | 259  |
| 216G      | 259  |
| 217G      | 259  |
| 218G      | 260  |
| 219G      | 260  |
| 220G      | 260  |
| 221G      | 260  |
| 222G      | 260  |
| 223G      | 260  |
| 224G      | 260  |
| 225G      | 260  |
| 226G      | 261  |
| 227G      | 261  |
| 228G      | 261  |
| 229G      | 261  |
| 230G      | 261  |
| 231G      | 261  |
| 232G      | 261  |
| 233G      | 261  |
| 234G      | 262  |
| 235G      | 262  |
| 236G      | 262  |
| 237G      | 262  |
| 238G      | 262  |
| 239G      | 262  |
| 303-1     | 1    |
| 303-1D    | 1    |
| 333-1D    | 1    |
| 333-2D    | 1    |
| 500       | 243  |
| 501       | 243  |
| 502       | 243  |
| 503       | 243  |
| 504       | 243  |
| 505       | 243  |
| 506       | 243  |
| 507       | 243  |
| 508       | 243  |
| 509       | 243  |
| 510       | 243  |
| 511       | 244  |
| 512       | 244  |
| 513       | 244  |
| 600G      | 263  |

| REF.  | PAG. |
|-------|------|
| 601G  | 263  |
| 602G  | 263  |
| 603G  | 263  |
| 604G  | 263  |
| 605G  | 263  |
| 606G  | 263  |
| 607G  | 263  |
| 608G  | 264  |
| 609G  | 264  |
| 610G  | 264  |
| 611G  | 264  |
| 612G  | 264  |
| 613G  | 264  |
| 614G  | 265  |
| 615G  | 265  |
| 616G  | 265  |
| 618G  | 265  |
| 619G  | 265  |
| 620G  | 265  |
| 622G  | 266  |
| 623G  | 266  |
| 624G  | 266  |
| 625G  | 266  |
| 626G  | 266  |
| 1200G | 267  |
| 1201G | 267  |
| 1202G | 267  |
| 1203G | 267  |
| 1204G | 267  |
| 1205G | 267  |
| 1206G | 267  |
| 1207G | 268  |
| 1208G | 268  |
| 1209G | 268  |
| 1210G | 268  |
| 1211G | 268  |
| 1212G | 269  |
| 1213G | 269  |
| 1214G | 269  |
| 1215G | 269  |
| 1216G | 269  |
| 1217G | 269  |
| 1218G | 270  |
| 1219G | 270  |
| 1220G | 270  |
| 1221G | 270  |
| 1241G | 270  |
| 1242G | 270  |
| 1243G | 270  |
| 1244G | 271  |
| 1245G | 271  |
| 1246G | 271  |
| 1247G | 271  |
| 1248G | 271  |
| 1249G | 271  |
| 1250G | 272  |
| 1251G | 272  |
| 1252G | 272  |
| 1253G | 272  |

| REF.  | PAG. |
|-------|------|
| 1254G | 272  |
| 1255G | 272  |
| 1256G | 272  |
| 1600G | 273  |
| 1601G | 273  |
| 1602G | 273  |
| 1603G | 273  |
| 1604G | 273  |
| 1605G | 273  |
| 1606G | 273  |
| 1607G | 273  |
| 1608G | 274  |
| 1609G | 274  |
| 1610G | 274  |
| 1611G | 274  |
| 1612G | 274  |
| 1613G | 274  |
| 1614G | 275  |
| 1615G | 275  |
| 1616G | 275  |
| 1617G | 275  |
| 1618G | 275  |
| 1619G | 275  |
| 1620G | 275  |
| 1621G | 276  |
| 1622G | 276  |
| 1623G | 276  |
| 1624G | 276  |
| 1625G | 276  |
| 1626G | 276  |

## A

|           |       |
|-----------|-------|
| A 1(L)    | 347   |
| A 1(N)    | 347   |
| A-0G      | 342   |
| A-0G(CV)  | 342   |
| A-1G      | 342   |
| A-1G(CV)  | 342   |
| A-1G-1    | 342   |
| A-1G-2    | 342   |
| A-1G-3    | 342   |
| A-1G-4    | 342   |
| A-1G-5    | 342   |
| A-1G-6    | 342   |
| A-2G      | 342   |
| A-2G(CV)  | 342   |
| A-2G-1    | 342   |
| A-3G      | 342   |
| A-3G(CV)  | 342   |
| A-4G      | 342   |
| A-5G      | 342   |
| AA-1G     | 343   |
| AA-1G(CV) | 343   |
| AA-2G     | 343   |
| AA-2G(CV) | 343   |
| AA-3G     | 343   |
| AA-3G(CV) | 343   |
| AB- 1D    | 2-160 |
| AB- 1I    | 2-160 |
| AB- 1T    | 2     |

| REF.    | PAG.  |
|---------|-------|
| AB- 2D  | 2-160 |
| AB- 2I  | 2-160 |
| AB- 2T  | 2     |
| AB- 3I  | 2     |
| AB- 3T  | 2     |
| AB- 4D  | 160   |
| AB- 4T  | 2     |
| AB- 5D  | 3-160 |
| AB- 5I  | 3-160 |
| AB- 6D  | 3-160 |
| AB- 6I  | 3-160 |
| AB- 7I  | 160   |
| AB- 8D  | 3-160 |
| AB- 8I  | 3-160 |
| AB- 9D  | 3     |
| AB-10I  | 160   |
| AB-11   | 3     |
| ABA-1   | 1     |
| ABC-1   | 1     |
| ABC-2   | 1     |
| ABC-3D  | 1     |
| ABC-5D  | 1     |
| ABC-5I  | 1     |
| ABC-6   | 2     |
| ABC-7   | 2     |
| ABL-1   | 2     |
| ABL-2   | 2     |
| ABL-3   | 2     |
| ABL-4   | 2     |
| ABL-5   | 2     |
| ABL-6   | 2     |
| ABU- 1  | 3     |
| ABU- 1D | 3     |
| ABU- 2D | 3     |
| ABU- 2G | 330   |
| ABU- 2I | 3     |
| ABU- 3  | 3     |
| ABU- 4D | 3     |
| ABU- 4I | 3     |
| ABU- 5D | 3     |
| ABU- 6D | 3     |
| ABU- 6I | 3     |
| ABU- 7D | 3     |
| ABU- 8D | 3     |
| ABU- 8I | 3     |
| ABU- 9D | 3     |
| ABU- 9I | 3     |
| ABU-10D | 3     |
| ABU-10I | 3     |
| ABU-11  | 4     |
| ABU-11D | 4     |
| ABU-12D | 3     |
| ABU-12I | 3     |
| ABU-13  | 4     |
| ABU-13D | 4     |
| ABU-14  | 3     |
| ABU-15  | 3     |
| ABU-15D | 3     |
| ABU-16  | 4     |
| ABU-17  | 4     |

# ÍNDICE GENERAL

## GENERAL INDEX

| REF.     | PAG.  | REF.     | PAG.  | REF.     | PAG. | REF.    | PAG. | REF.    | PAG. |
|----------|-------|----------|-------|----------|------|---------|------|---------|------|
| ABU-17D  | 4     | ABU-70   | 4     | ADPLE-55 | 282  | AGA- 1T | 7    | AGB-2   | 9    |
| ABU-18DP | 4-160 | ABU-71D  | 3     | ADS-1D   | 7    | AGA- 2G | 330  | AGB-3   | 9    |
| ABU-18P  | 4-160 | ABU-72P  | 6-160 | AEP-1D   | 7    | AGA- 2T | 7    | AGB-3D  | 9    |
| ABU-19D  | 4-160 | ABU-73D  | 6     | AEP-2D   | 7    | AGA- 3G | 330  | AGB-4   | 9    |
| ABU-19DP | 4-160 | ABU-74   | 3     | AF- 1D   | 224  | AGA- 3I | 7    | AGB-5   | 9    |
| ABU-19P  | 4-160 | ABU-74D  | 3     | AF- 1I   | 224  | AGA- 4D | 7    | AGD-1   | 9    |
| ABU-20   | 3     | ABU-75D  | 6     | AF- 2D   | 224  | AGA- 4G | 334  | AGD-1X  | 246  |
| ABU-21   | 4     | ABU-76   | 3     | AF- 2I   | 224  | AGA- 4I | 7    | AGD-2   | 9    |
| ABU-22D  | 4     | ABU-77   | 4     | AF- 3D   | 224  | AGA- 5D | 7    | AGD-2X  | 246  |
| ABU-23D  | 4     | ABU-78   | 6     | AF- 3I   | 224  | AGA- 5G | 330  | AGE-1I  | 9    |
| ABU-24D  | 4     | ABU-79   | 6     | AF- 4D   | 224  | AGA- 5I | 7    | AGE-2D  | 10   |
| ABU-25D  | 5     | ABU-80   | 4     | AF- 4I   | 224  | AGA- 6D | 7    | AGU-1D  | 10   |
| ABU-26D  | 5     | ABU-81   | 6     | AF- 5D   | 224  | AGA- 6G | 334  | AHR-2   | 10   |
| ABU-27   | 5     | ABU-83   | 4     | AF- 5I   | 224  | AGA- 6I | 7    | AHR-3   | 10   |
| ABU-27D  | 5     | ABU-84D  | 7     | AF- 6D   | 224  | AGA- 7  | 7    | AIZ-1   | 10   |
| ABU-28   | 5     | ABU-85   | 4     | AF- 6I   | 224  | AGA- 7G | 334  | AIZ-2D  | 10   |
| ABU-29P  | 5     | ABU-86D  | 7     | AF- 7D   | 226  | AGA- 8D | 8    | AKA-1PG | 293  |
| ABU-30   | 5     | AC- 9    | 349   | AF- 7I   | 226  | AGA- 8G | 334  | AKS-1   | 161  |
| ABU-30D  | 5     | AC-12    | 349   | AF- 7IP  | 226  | AGA- 9G | 334  | AL-1I   | 10   |
| ABU-32D  | 5     | AC-14    | 349   | AF- 7IP1 | 226  | AGA- 9I | 8    | AL-2    | 10   |
| ABU-34   | 5     | AC-15    | 349   | AF- 8D   | 226  | AGA-10  | 8    | AL-3    | 10   |
| ABU-35P  | 5-160 | AD- 1    | 281   | AF- 8DP  | 226  | AGA-11  | 8    | ALA-1X  | 246  |
| ABU-36P  | 5-160 | AD- 2    | 281   | AF- 8I   | 226  | AGA-12  | 8    | ALC-1D  | 11   |
| ABU-37D  | 3     | AD- 3    | 281   | AF- 8IP  | 226  | AGA-13I | 8    | ALE-1   | 10   |
| ABU-38D  | 5     | AD- 4    | 281   | AF- 9D   | 226  | AGA-14D | 8    | ALE-1D  | 10   |
| ABU-39P  | 5     | AD- 5    | 281   | AF- 9DP  | 226  | AGA-15  | 8    | ALE-1G  | 330  |
| ABU-40   | 5     | AD- 6    | 281   | AF- 9I   | 226  | AGA-15G | 339  | ALF- 1  | 11   |
| ABU-41   | 6     | AD- 7    | 281   | AF- 9IP  | 226  | AGA-16I | 8    | ALF- 2  | 11   |
| ABU-41D  | 6     | AD- 8    | 281   | AF-10    | 224  | AGA-18D | 7    | ALF- 3  | 11   |
| ABU-42   | 6     | AD- 9    | 281   | AF-11    | 224  | AGA-18I | 7    | ALF- 4  | 11   |
| ABU-42D  | 6     | AD-10    | 281   | AF-12    | 224  | AGA-19D | 7    | ALF- 5  | 11   |
| ABU-43D  | 3     | AD-11    | 281   | AF-13    | 179  | AGA-19I | 7    | ALF- 6  | 11   |
| ABU-44   | 3     | AD-12    | 281   | AF-13P   | 179  | AGA-20  | 8    | ALF- 7  | 11   |
| ABU-45   | 5     | AD-13    | 281   | AF-14    | 179  | AGA-22  | 8    | ALF- 8  | 11   |
| ABU-46   | 3     | AD-16    | 281   | AF-14P   | 179  | AGA-23  | 8    | ALF- 8D | 11   |
| ABU-46D  | 3     | AD-17    | 281   | AF-19    | 224  | AGA-23G | 339  | ALF- 9  | 11   |
| ABU-47   | 3     | AD-18    | 281   | AF-19P   | 224  | AGA-24D | 8    | ALF-10  | 11   |
| ABU-48   | 4     | AD-19    | 281   | AF-21    | 224  | AGA-24I | 8    | ALF-10D | 11   |
| ABU-49   | 3     | AD-20    | 281   | AF-21P   | 224  | AGA-25  | 8    | ALF-11D | 11   |
| ABU-50   | 6     | AD-21    | 281   | AG- 1D   | 10   | AGA-27G | 339  | ALF-12D | 11   |
| ABU-51D  | 6     | AD-23    | 281   | AG- 1I   | 10   | AGA-29  | 8    | ALF-13D | 11   |
| ABU-52D  | 3     | AD-24    | 281   | AG- 3D   | 10   | AGA-35G | 339  | ALF-14D | 11   |
| ABU-53   | 3     | AD-25    | 281   | AG- 3I   | 10   | AGA-38  | 8    | ALF-15  | 11   |
| ABU-54   | 6     | AD-26    | 281   | AG- 4D   | 10   | AGA-39  | 9    | ALF-16  | 11   |
| ABU-54D  | 6     | AD-27    | 281   | AG- 4I   | 10   | AGA-40G | 339  | ALF-17  | 11   |
| ABU-55   | 3     | AD-28    | 281   | AG- 5D   | 10   | AGA-42  | 8    | ALF-18  | 11   |
| ABU-55D  | 3     | AD-29    | 281   | AG- 5I   | 10   | AGA-43  | 9    | ALF-19  | 11   |
| ABU-57   | 6     | AD-33T   | 330   | AG- 6D   | 10   | AGA-44  | 9    | ALF-20  | 11   |
| ABU-57D  | 6     | AD-44-1  | 281   | AG- 6I   | 10   | AGA-46G | 340  | ALF-21  | 11   |
| ABU-58D  | 4     | AD-44-2  | 281   | AG- 8D   | 10   | AGA-48  | 8    | ALF-22D | 11   |
| ABU-60   | 6     | AD-44-3  | 281   | AG- 8I   | 10   | AGA-48G | 340  | ALF-23  | 11   |
| ABU-61   | 6     | AD-44-4  | 281   | AG- 9D   | 10   | AGA-49  | 9    | ALF-24  | 11   |
| ABU-63   | 6     | AD-44-5  | 281   | AG- 9I   | 10   | AGA-49G | 340  | ALF-25  | 11   |
| ABU-64P  | 6-160 | AD-44-6  | 281   | AG-10D   | 10   | AGA-50  | 9    | ALF-26  | 11   |
| ABU-65P  | 6-160 | AD-46    | 334   | AG-10I   | 10   | AGA-50G | 340  | ALF-27  | 11   |
| ABU-66   | 6     | AD-47    | 334   | AG-11    | 10   | AGA-51  | 9    | ALF-28  | 11   |
| ABU-67   | 3     | ADPLE-11 | 282   | AG-11D   | 10   | AGA-52  | 9    | ALF-29  | 11   |
| ABU-67D  | 3     | ADPLE-22 | 282   | AGA- 1G  | 283  | AGB-1   | 9    | ALF-30  | 11   |
| ABU-68   | 6     | ADPLE-33 | 282   | AGA- 1I  | 7    | AGB-1D  | 9    | ALF-31  | 11   |
| ABU-69   | 3     | ADPLE-44 | 282   |          |      |         |      |         |      |

| REF.    | PAG.   | REF.      | PAG. | REF.     | PAG. | REF.    | PAG. | REF.     | PAG. |
|---------|--------|-----------|------|----------|------|---------|------|----------|------|
| ALF-32D | 11     | ARC- 1G   | 330  | AS - 7D  | 15   | AS -FM7 | 16   | AS -RH7  | 16   |
| ALF-33  | 11     | ARC- 2G   | 330  | AS - 8D  | 15   | AS -G5  | 16   | AS -RK7  | 16   |
| ALF-34  | 11     | ARC- 3G   | 331  | AS - 9D  | 15   | AS -G7  | 16   | AS -RN7  | 16   |
| ALF-35  | 11     | ARC- 4G   | 331  | AS -10D  | 15   | AS -GG7 | 16   | AS -RR7  | 16   |
| ALF-36  | 11     | ARC- 5G   | 331  | AS -11D  | 15   | AS -GK5 | 16   | AS -S7   | 16   |
| ALI-1   | 37     | ARC- 6G   | 331  | AS -12D  | 15   | AS -GK7 | 16   | AS -SS7  | 16   |
| ALP-1D  | 11-161 | ARC- 7G   | 331  | AS -13D  | 15   | AS -GL5 | 16   | AS -T5   | 16   |
| ALP-1I  | 11-161 | ARC- 8G   | 331  | AS -14D  | 15   | AS -GL7 | 16   | AS -T7   | 16   |
| ALP-2   | 11-161 | ARC-10G   | 331  | AS -15D  | 15   | AS -GM5 | 16   | AS -TT7  | 17   |
| ALP-2D  | 11-161 | ARC-11G   | 331  | AS -16D  | 15   | AS -GM7 | 16   | AS -U5   | 16   |
| ALP-3   | 11     | ARC-12G   | 331  | AS -17D  | 161  | AS -H7  | 16   | AS -U7   | 16   |
| ALP-4D  | 11     | ARC-13G   | 331  | AS -18D  | 15   | AS -HH7 | 17   | AS -UU7  | 17   |
| ALP-5D  | 11     | ARC-14G   | 331  | AS -19D  | 161  | AS -K7  | 16   | AS -V5   | 16   |
| ALP-6   | 11-161 | ARC-15G   | 331  | AS -20D  | 15   | AS -KA7 | 17   | AS -V7   | 16   |
| ALP-6D  | 11-161 | ARC-16G   | 331  | AS -21   | 161  | AS -KD7 | 17   | AS -VV7  | 17   |
| AMA-1   | 11     | ARC-17DP  | 14   | AS -21D  | 161  | AS -KE5 | 17   | AS -W5   | 16   |
| AMA-1D  | 11     | ARC-17P   | 14   | AS -21DP | 161  | AS -KE7 | 17   | AS -W7   | 16   |
| AMB-1   | 1      | ARC-18PG  | 331  | AS -21P  | 161  | AS -KF7 | 17   | AS -WW7  | 17   |
| AMB-1D  | 1      | ARC-19PG  | 331  | AS -22   | 15   | AS -KG7 | 17   | AS -X7   | 16   |
| AME -1  | 12     | ARC-20PG  | 332  | AS -23   | 15   | AS -KK7 | 16   | AS -XX7  | 17   |
| AME -2  | 12     | ARC-21PG  | 332  | AS -23D  | 15   | AS -L7  | 16   | AS -Z7   | 16   |
| AME -4  | 12     | ARC-22PG  | 332  | AS -24   | 161  | AS -LA7 | 17   | ASH-2    | 15   |
| AMG- 1  | 12     | ARC-23PG  | 332  | AS -24D  | 161  | AS -LD7 | 17   | ASI-1    | 15   |
| AMG- 2D | 12     | ARC-24G   | 332  | AS -25D  | 15   | AS -LE7 | 17   | ASP-1D   | 15   |
| AMG- 3D | 12     | ARC-25G   | 332  | AS -28   | 15   | AS -LF7 | 17   | ATA-1    | 11   |
| AMG- 4D | 12     | ARC-26G   | 331  | AS -A5   | 16   | AS -LG7 | 17   | ATA-1D   | 11   |
| AMG- 5D | 12     | ARC-27PG  | 332  | AS -A7   | 16   | AS -M5  | 16   | ATR-1G   | 293  |
| AMG- 8D | 12     | ARE-1D    | 14   | AS -AK5  | 16   | AS -M7  | 16   | ATR-2G   | 294  |
| AMG- 9D | 12     | ARFE-1D   | 14   | AS -AK7  | 16   | AS -MA7 | 17   | ATR-2TG  | 294  |
| AMG-10  | 12     | ARFE-1I   | 14   | AS -AL5  | 16   | AS -MD7 | 17   | AU -1    | 185  |
| AMG-10D | 12     | ARFE-3D   | 14   | AS -AL7  | 16   | AS -ME5 | 17   | AU -AH   | 186  |
| AMM-1   | 161    | ARN-1     | 14   | AS -AM5  | 16   | AS -ME7 | 17   | AU -AHP  | 186  |
| AMM-2   | 161    | ARN-2     | 14   | AS -AM7  | 16   | AS -MF7 | 17   | AU -AHP1 | 186  |
| ANA-1   | 13     | ARN-2D    | 14   | AS -B5   | 16   | AS -MG5 | 17   | AU -AN   | 186  |
| ANA-1D  | 13     | ARN-3     | 14   | AS -B7   | 16   | AS -MG7 | 17   | AU -ANP  | 186  |
| ANC-1D  | 12     | ARN-3D    | 14   | AS -BK5  | 16   | AS -MM5 | 16   | AU -C    | 186  |
| ANC-2   | 13     | ARO-1D    | 14   | AS -BK7  | 16   | AS -MM7 | 16   | AU -HV   | 186  |
| ANK- 1  | 13     | ARR-1     | 14   | AS -BL7  | 16   | AS -N5  | 16   | AU -HVP  | 186  |
| ANK- 2  | 13     | ARR-2     | 14   | AS -BM7  | 16   | AS -N7  | 16   | AU -HVP1 | 186  |
| ANK- 3  | 13     | ARR-3     | 14   | AS -D7   | 16   | AS -NN5 | 16   | AU -W    | 186  |
| ANK- 4  | 13     | ARR-7D    | 14   | AS -DD7  | 17   | AS -NN7 | 16   | AUM-2D   | 17   |
| ANK- 6  | 13     | ARR-8     | 14   | AS -DK5  | 16   | AS -P5  | 16   | AV-1     | 17   |
| ANK-17  | 13     | ARR-9D    | 14   | AS -DK7  | 16   | AS -P7  | 16   | AV-1D    | 17   |
| ANK-47D | 13     | ARS-1D    | 15   | AS -DL5  | 16   | AS -PA7 | 17   | AV-2D    | 17   |
| ANK-65  | 13     | AS - 1D   | 161  | AS -DL7  | 16   | AS -PB7 | 17   | AX-1     | 161  |
| ANT-1G  | 293    | AS - 1G   | 283  | AS -DM5  | 16   | AS -PF7 | 17   | AX-1D    | 161  |
| ANT-2G  | 293    | AS - 1I   | 161  | AS -DM7  | 16   | AS -PG7 | 17   | AX-1DP   | 162  |
| ANT-3G  | 293    | AS - 2D   | 161  | AS -E5   | 16   | AS -PH7 | 17   | AX-1P    | 162  |
| ANT-4G  | 293    | AS - 2G   | 283  | AS -E7   | 16   | AS -PN7 | 17   | AX-2P    | 162  |
| ANT-5G  | 293    | AS - 2I   | 161  | AS -EK5  | 16   | AS -PP7 | 16   | AX-2P1   | 162  |
| AP-1D   | 13     | AS - 3D   | 15   | AS -EK7  | 16   | AS -PR7 | 17   | AX-3DP   | 162  |
| AP-2D   | 13     | AS - 3G   | 283  | AS -EL5  | 16   | AS -PT7 | 17   | AX-4DP   | 162  |
| AP-3D   | 13     | AS - 3I   | 15   | AS -EL7  | 16   | AS -R7  | 16   | AYP-1G   | 332  |
| AP-4D   | 13     | AS - 4D   | 15   | AS -EM5  | 16   | AS -RA7 | 16   | AZ- 1D   | 17   |
| AP-5D   | 14     | AS - 4G   | 293  | AS -EM7  | 16   | AS -RB7 | 16   | AZ- 1I   | 17   |
| APEC-1G | 334    | AS - 5D   | 15   | AS -F5   | 16   | AS -RC7 | 16   | AZ- 2D   | 17   |
| APEC-2G | 335    | AS - 5G   | 332  | AS -F7   | 16   | AS -RD7 | 16   | AZ- 2I   | 17   |
| AR-1D   | 14     | AS - 6D   | 15   | AS -FK5  | 16   | AS -RE7 | 16   | AZ- 3D   | 17   |
| AR-4DP  | 14     | AS - 6G-1 | 283  | AS -FK7  | 16   | AS -RF7 | 16   | AZ- 3I   | 17   |
| AR-4IP  | 14     | AS - 6G-2 | 284  | AS -FL7  | 16   | AS -RG7 | 16   | AZ- 4    | 17   |



# ÍNDICE GENERAL

## GENERAL INDEX

| REF.    | PAG. | REF.    | PAG. | REF.       | PAG. | REF.     | PAG. | REF.      | PAG.   |
|---------|------|---------|------|------------|------|----------|------|-----------|--------|
| AZ- 6   | 17   | BCZ-2   | 20   | BK- 9      | 23   | BK-18/20 | 24   | BLU-1X    | 246    |
| AZ- 7   | 18   | BD-1    | 18   | BK-14      | 23   | BK-18/21 | 24   | BLU-2X    | 246    |
| AZ- 8D  | 18   | BDA-1   | 20   | BK-16/ 0   | 23   | BK-18/22 | 24   | BM -1P    | 186    |
| AZ- 9   | 18   | BE- 1   | 21   | BK-16/ 1   | 23   | BK-18/23 | 24   | BM -2     | 186    |
| AZ- 9D  | 18   | BE- 1G  | 294  | BK-16/ 2   | 23   | BK-18/24 | 24   | BM -2P    | 187    |
| AZ-10   | 18   | BE- 3G  | 294  | BK-16/ 3   | 23   | BK-18/25 | 24   | BM -3     | 187    |
| AZ-12   | 18   | BE- 4D  | 21   | BK-16/ 4   | 23   | BK-18/26 | 24   | BM -3P    | 187    |
| AZ-14   | 18   | BE- 4G  | 294  | BK-16/ 5   | 23   | BK-18/27 | 24   | BM -4     | 187    |
| AZ-17   | 18   | BE- 4I  | 21   | BK-16/ 7   | 23   | BK-18/28 | 24   | BM -5P    | 187    |
| AZ-17D  | 18   | BE- 5D  | 21   | BK-16/ 9   | 23   | BK-18/29 | 24   | BM -6P    | 187    |
| AZ-18   | 18   | BE- 5G  | 294  | BK-16/10   | 23   | BK-18/30 | 24   | BM -6P1C1 | 187    |
| AZ-18D  | 18   | BE- 5I  | 21   | BK-16/13   | 23   | BK-18/31 | 24   | BM -B     | 187    |
| AZ-29   | 18   | BE- 6G  | 294  | BK-16/14   | 23   | BK-18/32 | 24   | BM -HB    | 187    |
| AZ-32   | 18   | BE- 7G  | 294  | BK-16/15   | 23   | BK-18/33 | 24   | BM -HBP   | 187    |
| AZ-37   | 18   | BE-10G  | 295  | BK-16/16   | 23   | BK-18/34 | 24   | BM -HBP1  | 187    |
| AZ-37D  | 18   | BES- 1D | 21   | BK-16/17   | 23   | BK-18/35 | 24   | BM -NB    | 187    |
| AZKO-1I | 18   | BES- 2D | 21   | BK-16/18   | 23   | BK-19/ 1 | 24   | BM -NBP   | 187    |
|         |      | BES- 3D | 21   | BK-16/19   | 23   | BK-19/ 2 | 24   | BM -W     | 187    |
|         |      | BES- 4D | 21   | BK-16/20   | 23   | BK-19/ 4 | 24   | BMB-1     | 24     |
|         |      | BES- 5D | 21   | BK-16/21   | 23   | BK-19/ 5 | 24   | BMB-2     | 24     |
|         |      | BES- 6D | 21   | BK-16/23   | 23   | BK-19/ 6 | 24   | BMB-3D    | 24     |
|         |      | BES- 7D | 21   | BK-16/30   | 23   | BK-19/ 7 | 24   | BMC-1G    | 295    |
|         |      | BES- 8D | 21   | BK-17/1    | 23   | BK-19/ 8 | 24   | BOB-1D    | 163    |
|         |      | BES- 9D | 21   | BK-17/1PZ  | 23   | BK-19/10 | 24   | BOD-1     | 24     |
|         |      | BES-10D | 21   | BK-17/2    | 23   | BK-19/11 | 24   | BOD-1G    | 295    |
|         |      | BES-11D | 21   | BK-17/2PZ  | 23   | BK-19/12 | 24   | BOD-2G    | 295    |
|         |      | BES-12D | 21   | BK-17/3    | 23   | BK-19/13 | 24   | BOD-3G    | 295    |
|         |      | BES-13D | 21   | BK-17/4    | 23   | BK-19/14 | 24   | BOD-4G    | 284    |
|         |      | BES-14D | 21   | BK-17/4PZ  | 23   | BK-19/15 | 24   | BOD-5G    | 284    |
|         |      | BES-15D | 21   | BK-17/5    | 23   | BK-19/16 | 24   | BOG-1G    | 295    |
|         |      | BES-16D | 21   | BK-17/5PZ  | 23   | BK-19/19 | 24   | BOG-2G    | 295    |
|         |      | BES-17D | 21   | BK-17/6    | 23   | BK-19/20 | 24   | BOM-1     | 25     |
|         |      | BEY-1D  | 21   | BK-17/6PZ  | 23   | BK-19/21 | 24   | BOM-1D    | 25     |
|         |      | BEY-2D  | 21   | BK-17/7    | 23   | BK-19/23 | 24   | BOM-2     | 25-163 |
|         |      | BH-1    | 163  | BK-17/7PZ  | 23   | BK-19/25 | 24   | BOM-2D    | 25-163 |
|         |      | BH-1P   | 163  | BK-17/8    | 23   | BK-19/26 | 24   | BON-3G    | 262    |
|         |      | BH-2    | 163  | BK-17/8PZ  | 23   | BK-19/27 | 24   | BOX-1G    | 295    |
|         |      | BH-3    | 163  | BK-17/9    | 23   | BK-19/31 | 24   | BRA-1     | 99     |
|         |      | BH-4    | 163  | BK-17/9PZ  | 23   | BK-19/32 | 24   | BRA-2     | 25-163 |
|         |      | BH-5    | 163  | BK-17D/1PZ | 23   | BK-20    | 24   | BRAS -1   | 25     |
|         |      | BH-6    | 163  | BK-17D/2PZ | 23   | BK-21/ 1 | 22   | BRI- 1D   | 25     |
|         |      | BH-8    | 163  | BK-17D/3PZ | 23   | BK-21/ 2 | 22   | BRI- 1I   | 25     |
|         |      | BI-1D   | 21   | BK-17D/4PZ | 23   | BK-21/ 7 | 22   | BRI- 1X   | 246    |
|         |      | BI-2    | 22   | BK-18/ 1   | 24   | BK-21/ 9 | 22   | BRI- 2D   | 25     |
|         |      | BI-3D   | 22   | BK-18/ 2   | 24   | BK-21/14 | 22   | BRI- 2I   | 25     |
|         |      | BIE-1   | 22   | BK-18/ 3   | 24   | BK-21/17 | 22   | BRI- 2X   | 246    |
|         |      | BIF-1   | 22   | BK-18/ 4   | 24   | BK-21/19 | 22   | BRI- 3D   | 25     |
|         |      | BIL-1T  | 22   | BK-18/ 5   | 24   | BKY-1    | 25   | BRI- 3I   | 25     |
|         |      | BK- 1D  | 22   | BK-18/ 6   | 24   | BKY-2    | 25   | BRI- 3X   | 246    |
|         |      | BK- 1I  | 22   | BK-18/ 7   | 24   | BL-1D    | 162  | BRI- 4D   | 25     |
|         |      | BK- 2D  | 22   | BK-18/ 9   | 24   | BL-1I    | 162  | BRI- 4I   | 25     |
|         |      | BK- 3D  | 22   | BK-18/10   | 24   | BL-2     | 162  | BRI- 6D   | 25     |
|         |      | BK- 4   | 22   | BK-18/11   | 24   | BL-3     | 162  | BRI- 6I   | 25     |
|         |      | BK- 4D  | 22   | BK-18/12   | 24   | BL-4     | 162  | BRI- 6L 1 | 284    |
|         |      | BK- 5D  | 22   | BK-18/13   | 24   | BL-4D    | 162  | BRI- 6L 2 | 284    |
|         |      | BK- 5I  | 22   | BK-18/14   | 24   | BL-5     | 162  | BRI- 6L 7 | 284    |
|         |      | BK- 6D  | 22   | BK-18/15   | 24   | BL-5D    | 162  | BRI- 6L 8 | 284    |
|         |      | BK- 6I  | 22   | BK-18/16   | 24   | BL-6     | 162  | BRI- 6L11 | 284    |
|         |      | BK- 7D  | 22   | BK-18/17   | 24   | BL-6D    | 162  | BRI- 6L12 | 284    |
|         |      | BK- 8D  | 23   | BK-18/18   | 24   | BLT-1    | 20   | BRI- 6L17 | 284    |

| REF.      | PAG. | REF.    | PAG.   | REF.     | PAG. | REF.    | PAG. | REF.      | PAG. |
|-----------|------|---------|--------|----------|------|---------|------|-----------|------|
| BRI- 6L18 | 284  | BTV-2I  | 27     | BUR-33   | 30   | CE- 12D | 33   | CE- 70    | 34   |
| BRI- 6L21 | 284  | BTV-3   | 27     | BUR-34   | 30   | CE- 13D | 33   | CE- 71    | 34   |
| BRI- 6L22 | 284  | BU-1D   | 30     | BUS-1    | 30   | CE- 14D | 33   | CE- 72    | 34   |
| BRI- 6L29 | 284  | BU-1I   | 30     | <b>C</b> |      | CE- 15D | 33   | CE- 73    | 34   |
| BRI- 6L30 | 284  | BUL-1   | 27     | C        | 30   | CE- 16D | 33   | CE- 74    | 34   |
| BRI- 7D   | 25   | BUL-2D  | 27     | C-2      | 31   | CE- 17D | 33   | CE- 75    | 34   |
| BRI- 8I   | 25   | BUL-3D  | 27     | C-3G     | 343  | CE- 18D | 33   | CE- 76    | 34   |
| BRI- 9D   | 25   | BUL-4D  | 27     | C-3G(CV) | 343  | CE- 19D | 33   | CE- 77    | 34   |
| BRI-10    | 26   | BUL-5D  | 28     | CA- 1I   | 31   | CE- 20D | 33   | CE- 78    | 34   |
| BRI-12    | 26   | BUL-6D  | 27     | CA- 2I   | 31   | CE- 21D | 33   | CE- 79    | 34   |
| BRI-13    | 25   | BUL-7D  | 28     | CA- 3I   | 31   | CE- 22D | 33   | CE- 80    | 34   |
| BRI-14    | 25   | BUR- 1D | 28     | CA- 4D   | 31   | CE- 23D | 33   | CE- 81    | 34   |
| BRI-14D   | 25   | BUR- 1G | 335    | CA- 4I   | 31   | CE- 24D | 33   | CE- 82    | 34   |
| BRI-15    | 25   | BUR- 1I | 28     | CA- 5I   | 31   | CE- 25D | 33   | CE- 83    | 34   |
| BRI-16    | 26   | BUR- 1X | 246    | CA- 6D   | 31   | CE- 26D | 33   | CE- 84    | 34   |
| BRI-17    | 25   | BUR- 2D | 28     | CA- 7    | 32   | CE- 27D | 33   | CE- 85    | 34   |
| BRI-18    | 26   | BUR- 2I | 28     | CA- 7D   | 32   | CE- 28D | 33   | CE- 86    | 34   |
| BRI-18D   | 26   | BUR- 2X | 247    | CA- 8D   | 32   | CE- 29D | 33   | CE- 87    | 34   |
| BRI-19    | 26   | BUR- 3  | 28     | CA- 8I   | 32   | CE- 30D | 33   | CE- 88    | 34   |
| BRI-20    | 25   | BUR- 3D | 28     | CA- 9I   | 31   | CE- 31D | 33   | CE- 89    | 34   |
| BRI-21    | 25   | BUR- 3X | 247    | CA-10I   | 31   | CE- 32D | 33   | CE- 89D   | 34   |
| BRI-22    | 26   | BUR- 4  | 28     | CA-11I   | 31   | CE- 33D | 33   | CE- 90D   | 34   |
| BRI-23    | 26   | BUR- 4D | 28     | CA-12I   | 31   | CE- 34D | 33   | CE- 92    | 33   |
| BRI-24    | 26   | BUR- 4X | 247    | CA-13D   | 31   | CE- 35D | 33   | CE- 92D   | 33   |
| BRI-25    | 26   | BUR- 5  | 28     | CA-14D   | 32   | CE- 36D | 33   | CE- 93D   | 33   |
| BRI-26    | 26   | BUR- 5D | 28     | CA-14D   | 32   | CE- 37D | 33   | CE- 94    | 34   |
| BRI-27    | 26   | BUR- 5X | 247    | CA-15I   | 32   | CE- 38D | 33   | CE- 96    | 34   |
| BRI-28    | 26   | BUR- 6  | 28-164 | CAB-1D   | 30   | CE- 39D | 33   | CE- 97    | 34   |
| BRI-29    | 26   | BUR- 7  | 28     | CAF-1G   | 296  | CE- 40D | 33   | CE- 98D   | 35   |
| BRI-30    | 26   | BUR- 8D | 28     | CAF-2G   | 296  | CE- 41D | 33   | CE- 99D   | 33   |
| BRI-31    | 26   | BUR- 9  | 28     | CAM-1D   | 164  | CE- 42D | 33   | CE-100D   | 33   |
| BRI-32D   | 26   | BUR- 9D | 28     | CAS -1D  | 164  | CE- 43D | 33   | CE-101D   | 33   |
| BRI-33    | 26   | BUR-10  | 28     | CAT-1P   | 164  | CE- 44D | 33   | CE-102    | 35   |
| BRI-34    | 26   | BUR-10D | 28     | CAT-2    | 164  | CE- 45D | 33   | CE-103    | 35   |
| BRR-1     | 20   | BUR-11D | 29     | CAT-3    | 164  | CE- 46D | 33   | CE-104D   | 35   |
| BRS-1     | 25   | BUR-12  | 29     | CAY-1D   | 32   | CE- 47D | 33   | CE-105    | 35   |
| BRU -1    | 26   | BUR-13D | 29     | CAY-1I   | 32   | CE- 48D | 33   | CE-106    | 35   |
| BRU -1D   | 26   | BUR-14  | 29     | CAY-2    | 32   | CE- 49  | 34   | CE-107    | 35   |
| BS-1I     | 163  | BUR-14D | 29     | CCF- 1X  | 247  | CE- 49D | 34   | CE-108    | 33   |
| BS-2      | 164  | BUR-15  | 29     | CCF- 5X  | 247  | CE- 50  | 34   | CE-109D   | 35   |
| BS-4D     | 164  | BUR-16  | 29     | CCF- 8X  | 247  | CE- 51  | 34   | CE-110    | 33   |
| BS-5      | 164  | BUR-17  | 29     | CCF- 9X  | 247  | CE- 51D | 34   | CE-111D   | 35   |
| BS-6      | 164  | BUR-17D | 29     | CCF-10X  | 248  | CE- 52  | 34   | CE-114    | 35   |
| BS-7      | 164  | BUR-18D | 29     | CE- 1D   | 33   | CE- 53D | 34   | CE-117D   | 35   |
| BS-7D     | 164  | BUR-19D | 29     | CE- 1I   | 33   | CE- 54  | 34   | CE-118D   | 33   |
| BS-8      | 164  | BUR-20D | 29     | CE- 2D   | 33   | CE- 55  | 34   | CE-130    | 35   |
| BS-8D     | 164  | BUR-21D | 29     | CE- 2I   | 33   | CE- 56  | 34   | CE-131D   | 35   |
| BS-9      | 164  | BUR-22D | 29     | CE- 3D   | 33   | CE- 57  | 34   | CE-132/15 | 35   |
| BS-9D     | 164  | BUR-23D | 29     | CE- 3I   | 33   | CE- 58  | 34   | CE-132/16 | 35   |
| BSS-1D    | 26   | BUR-24  | 29     | CE- 4D   | 33   | CE- 59  | 34   | CE-132/17 | 35   |
| BSS-2     | 26   | BUR-24D | 29     | CE- 5    | 33   | CE- 60  | 34   | CE-132/18 | 35   |
| BSS-2D    | 26   | BUR-25D | 29     | CE- 5D   | 33   | CE- 61  | 34   | CE-132/25 | 35   |
| BSS-3     | 27   | BUR-26D | 30     | CE- 6D   | 33   | CE- 62  | 34   | CE-132/26 | 35   |
| BSS-4D    | 27   | BUR-27D | 28     | CE- 6I   | 33   | CE- 63  | 34   | CE-132/27 | 35   |
| BSS-5D    | 27   | BUR-28  | 30     | CE- 7D   | 33   | CE- 64  | 34   | CE-132/35 | 35   |
| BSS-6D    | 27   | BUR-29  | 30     | CE- 7I   | 33   | CE- 65  | 34   | CE-132/36 | 35   |
| BSS-7D    | 27   | BUR-29D | 30     | CE- 8D   | 33   | CE- 66  | 34   | CE-132/37 | 35   |
| BTV-1D    | 27   | BUR-30D | 164    | CE- 9D   | 33   | CE- 67  | 34   | CE-132/38 | 35   |
| BTV-1I    | 27   | BUR-31D | 30     | CE- 10D  | 33   | CE- 68  | 34   | CE-132/45 | 35   |
| BTV-2D    | 27   | BUR-32D | 30     | CE- 11D  | 33   | CE- 69  | 34   | CE-132/46 | 35   |

# ÍNDICE GENERAL

## GENERAL INDEX

| REF.     | PAG. | REF.     | PAG. | REF.    | PAG. | REF.      | PAG.   | REF.        | PAG. |
|----------|------|----------|------|---------|------|-----------|--------|-------------|------|
| CE-134   | 35   | CHU - 1G | 284  | CI -32  | 38   | CIS-1D    | 31     | COR- 7      | 41   |
| CE-135D  | 35   | CHU - 2G | 284  | CI -33  | 38   | CIS-1I    | 31     | COR- 8      | 41   |
| CEM-BP   | 164  | CHU - 4G | 297  | CI -34  | 39   | CIS-2     | 31     | COR- 9      | 41   |
| CEM-JC   | 165  | CHU - 5G | 297  | CI -34D | 39   | CIS-3     | 31     | COR- 10     | 41   |
| CENT-1D  | 32   | CHU -10  | 36   | CI -35  | 38   | CIS-4     | 31     | COR- 11     | 41   |
| CENT-1I  | 32   | CI - 1D  | 37   | CI -36  | 39   | CIS-5     | 31     | COR- 11D    | 41   |
| CENT-2D  | 32   | CI - 1G  | 298  | CI -38D | 39   | CIS-6D    | 31     | COR- 12     | 41   |
| CENT-2I  | 32   | CI - 1I  | 37   | CI -39D | 37   | CIS-7D    | 31     | COR- 13     | 41   |
| CENT-3D  | 32   | CI - 1PG | 298  | CI -3PG | 298  | CIS-803-1 | 340    | COR- 13D    | 41   |
| CENT-4   | 32   | CI - 2   | 39   | CI -41  | 39   | CIS-803-2 | 340    | COR- 15D    | 41   |
| CER-1    | 32   | CI - 2G  | 298  | CI -42  | 39   | CIS-803-3 | 340    | COR- 16D    | 41   |
| CER-1G   | 314  | CI - 2I  | 39   | CI -43D | 39   | CIS-803-4 | 340    | COR- 17D    | 41   |
| CER-2G   | 314  | CI - 3D  | 37   | CI -44D | 38   | CIS-803-5 | 340    | COR- 18D    | 41   |
| CER-3G   | 314  | CI - 3G  | 298  | CI -45D | 39   | CIS-803-6 | 340    | COR- 19D    | 41   |
| CER-4G   | 314  | CI - 4D  | 37   | CI -46D | 39   | CL-1I     | 40-166 | COR- 20     | 41   |
| CF-1D    | 36   | CI - 4DP | 37   | CI -48  | 39   | CL-2D     | 166    | COR- 20-25  | 42   |
| CF-1I    | 36   | CI - 4G  | 298  | CI -49  | 39   | CL-2I     | 166    | COR- 20D    | 41   |
| CHA-2    | 36   | CI - 4I  | 37   | CI -51  | 39   | CL-3I     | 167    | COR- 21D    | 41   |
| CHA-2D   | 36   | CI - 4IP | 37   | CI -51D | 39   | CL-4I     | 167    | COR- 22D    | 41   |
| CHEK-1   | 36   | CI - 5DP | 38   | CI -53  | 39   | CL-5D     | 167    | COR- 23D    | 42   |
| CHI- 1   | 36   | CI - 5IP | 38   | CI -55D | 39   | CL-6      | 167    | COR- 24     | 42   |
| CHI- 1T  | 36   | CI - 5PG | 298  | CI -56  | 38   | CL-6P     | 167    | COR- 24D    | 42   |
| CHI- 2   | 36   | CI - 6D  | 38   | CI -57  | 39   | CL-7P     | 167    | COR- 25     | 42   |
| CHI- 3   | 36   | CI - 6G  | 298  | CI -58D | 38   | CL-8P     | 167    | COR- 25I    | 42   |
| CHI- 4   | 36   | CI - 6I  | 38   | CI -59  | 38   | CL-9P     | 167    | COR- 26     | 42   |
| CHI- 5   | 36   | CI - 6PG | 299  | CI -60  | 38   | CLA-3G    | 299    | COR- 27D    | 42   |
| CHI- 6   | 36   | CI - 7D  | 38   | CI -61  | 39   | CLF-1     | 40     | COR- 28     | 42   |
| CHI- 7D  | 36   | CI - 7TG | 299  | CI -62  | 39   | CLI-1D    | 167    | COR- 29D    | 42   |
| CHI- 8D  | 36   | CI - 8D  | 39   | CI -62D | 39   | CLK-1     | 44     | COR- 30     | 42   |
| CHI- 9D  | 36   | CI - 8G  | 299  | CI -63  | 39   | CLS-1D    | 40     | COR- 31     | 42   |
| CHI-10D  | 36   | CI - 9D  | 39   | CI -63D | 39   | CLU-1D    | 167    | COR- 32     | 42   |
| CHI-12D  | 36   | CI - 9PG | 299  | CI -64D | 39   | CLU-1I    | 167    | COR- 33     | 42   |
| CHR- 1   | 165  | CI -10D  | 39   | CI -65  | 39   | CLU-2     | 167    | COR- 34     | 42   |
| CHR- 2   | 165  | CI -10G  | 298  | CI -66D | 39   | CLU-3     | 167    | COR- 35     | 43   |
| CHR- 3   | 165  | CI -11D  | 39   | CI -67  | 38   | CLU-4     | 167    | COR- 36D    | 41   |
| CHR- 3P  | 165  | CI -12   | 39   | CI -69  | 39   | CLU-5     | 167    | COR- 37     | 43   |
| CHR- 4D  | 222  | CI -12TG | 299  | CI -70  | 39   | CMA-1     | 32     | COR- 40     | 43   |
| CHR- 4I  | 222  | CI -13   | 39   | CI -71  | 39   | CMA-1D    | 32     | COR- 48     | 41   |
| CHR- 5   | 165  | CI -13G  | 299  | CI -72  | 39   | CMA-2     | 32     | COR- 49     | 41   |
| CHR- 6   | 165  | CI -14   | 38   | CI -73  | 39   | CMA-2D    | 32     | COR- 50-60  | 43   |
| CHR- 6D  | 165  | CI -14G  | 299  | CI -DL  | 39   | CML-1     | 30     | COR- 50-60I | 43   |
| CHR- 7   | 165  | CI -15   | 39   | CI -IL  | 39   | CN-1D     | 165    | COR- 62     | 43   |
| CHR- 7P  | 165  | CI -15D  | 39   | CIE-1D  | 36   | CO -1D    | 43     | COR- 64     | 41   |
| CHR- 8   | 165  | CI -16D  | 39   | CIF-1D  | 37   | CO -M     | 44     | COR- 65     | 41   |
| CHR- 8P  | 165  | CI -17   | 38   | CIF-1X  | 248  | COB-1     | 167    | COR- 66     | 41   |
| CHR- 9   | 165  | CI -18   | 39   | CIF-2D  | 37   | COB-1P    | 168    | COR- 67     | 41   |
| CHR- 9P  | 165  | CI -19D  | 38   | CIF-3   | 37   | COB-2     | 168    | COR- 68     | 41   |
| CHR-10   | 166  | CI -20   | 38   | CIF-3D  | 37   | COH-1     | 40     | COR- 69     | 41   |
| CHR-10P  | 166  | CI -20D  | 38   | CIF-4   | 37   | COH-2     | 40     | COR- 70D    | 43   |
| CHR-11   | 166  | CI -21   | 38   | CIL-1   | 37   | COH-2D    | 40     | COR- 71     | 41   |
| CHR-11P  | 166  | CI -22D  | 38   | CIL-1D  | 37   | COH-3     | 40     | COR- 72     | 41   |
| CHR-12   | 166  | CI -23D  | 38   | CIL-2D  | 37   | COH-4     | 40     | COR- 73     | 41   |
| CHR-13D  | 166  | CI -24   | 38   | CIL-3D  | 37   | COM-1D    | 40     | COR- 74     | 41   |
| CHR-14   | 166  | CI -25   | 38   | CIL-4   | 37   | COR- 1D   | 41     | COR- 76D    | 41   |
| CHR-14P  | 166  | CI -26   | 38   | CIL-4D  | 37   | COR- 1GD  | 41     | COR- 77     | 43   |
| CHR-15   | 166  | CI -27   | 39   | CIL-5D  | 37   | COR- 1I   | 41     | COR- 78     | 43   |
| CHR-15P  | 166  | CI -28D  | 38   | CIN-1   | 37   | COR- 2D   | 41     | COR- 79     | 41   |
| CHR-17   | 166  | CI -29   | 39   | CIN-1D  | 37   | COR- 2I   | 41     | COR- 80     | 41   |
| CHTZ-1   | 36   | CI -30   | 38   | CIN-2   | 37   | COR- 3    | 41     | COR-114     | 43   |
| CHU - 1D | 36   | CI -31   | 38   | CIN-2D  | 37   | COR- 3D   | 41     | COR-115D    | 43   |

| REF.    | PAG. | REF.      | PAG. | REF.     | PAG.   | REF.      | PAG.   | REF.       | PAG. |
|---------|------|-----------|------|----------|--------|-----------|--------|------------|------|
| COR-153 | 43   | DAC-1DP   | 168  | DAT- 9D  | 219    | DMR-6-2   | 285    | DOM-27/16  | 48   |
| COR-223 | 43   | DAC-2D    | 168  | DAT- 9DP | 219    | DMR-6-2L  | 285    | DOM-27/19  | 48   |
| COT-1D  | 44   | DAC-3DC1  | 168  | DAT- 9I  | 219    | DMR-6-3   | 285    | DOM-27/35  | 48   |
| CR- 1G  | 300  | DAC-4DC1  | 168  | DAT- 9IP | 219    | DMR-6-3L  | 285    | DOM-27D/ 1 | 49   |
| CR- 2G  | 300  | DAC-5C1   | 168  | DAT-10   | 219    | DMR-6-4   | 285    | DOM-27D/ 2 | 49   |
| CR- 3G  | 300  | DAD-1D    | 44   | DAT-10P  | 220    | DMR-6-4L  | 285    | DOM-27D/ 3 | 49   |
| CR- 4G  | 300  | DAD-1I    | 44   | DAT-11   | 220    | DMR-7-1   | 285    | DOM-27D/ 4 | 49   |
| CR- 5G  | 300  | DAD-2D    | 44   | DAT-11D  | 220    | DMR-7-2   | 285    | DOM-27D/ 5 | 49   |
| CR- 8G  | 300  | DAD-2I    | 44   | DAT-11DP | 220    | DMR-7-3   | 285    | DOM-27D/ 6 | 49   |
| CR-10G  | 300  | DAD-3D    | 44   | DAT-11P  | 220    | DMR-7-4   | 285    | DOM-27D/ 7 | 49   |
| CR-11G  | 301  | DAD-4D    | 44   | DAT-12   | 220    | DO-2I     | 51     | DOM-27D/ 8 | 49   |
| CR-12G  | 301  | DAD-5D    | 44   | DAT-13   | 220    | DO-3      | 51     | DOM-27D/ 9 | 49   |
| CR-14G  | 301  | DAD-6D    | 44   | DAT-13P  | 220    | DO-4      | 51     | DOM-27D/10 | 49   |
| CR-17TG | 301  | DAE-1P    | 168  | DAT-14   | 220    | DO-5      | 52     | DOM-27D/11 | 49   |
| CR-18G  | 301  | DAE-2DP   | 168  | DAT-14P  | 220    | DO-5D     | 52     | DOM-27D/12 | 49   |
| CR-19G  | 301  | DAE-3D    | 168  | DAT-15   | 220    | DO-7      | 52     | DOM-27D/13 | 49   |
| CRC-1X  | 248  | DAE-3DP1  | 168  | DAT-15C1 | 220    | DOB-1     | 169    | DOM-27D/14 | 49   |
| CRN-1G  | 300  | DAE-3DP2  | 169  | DAT-15C2 | 220    | DOB-1D    | 169    | DOM-27D/15 | 49   |
| CRO-1G  | 335  | DAE-3P2   | 169  | DAT-15P  | 220    | DOB-2     | 169    | DOM-27D/16 | 49   |
| CRT- 1G | 296  | DAE-4D    | 168  | DAT-16   | 220    | DOB-2D    | 169    | DOM-27D/17 | 49   |
| CRT- 2G | 296  | DAE-4DP1  | 168  | DAT-17   | 220    | DOB-3     | 169    | DOM-27D/18 | 49   |
| CRT- 3G | 296  | DAE-4P1   | 168  | DAT-17D  | 220    | DOB-3D    | 169    | DOM-27D/19 | 49   |
| CRT- 4G | 296  | DAE-5P    | 169  | DAT-18   | 221    | DOI-1     | 51     | DOM-27D/20 | 49   |
| CRT- 7G | 296  | DAF-1     | 45   | DAT-19   | 221    | DOI-4     | 51     | DOM-27D/21 | 49   |
| CRT- 8G | 296  | DAF-1D    | 45   | DAT-19P  | 221    | DOL-1X    | 248    | DOM-27D/22 | 49   |
| CRT-10G | 332  | DAF-2     | 45   | DAT-20   | 221    | DOM- 1D   | 46     | DOM-27D/23 | 49   |
| CRT-11G | 297  | DAF-3D    | 45   | DAT-20P  | 221    | DOM- 1DP  | 47     | DOM-27D/24 | 49   |
| CRT-12G | 297  | DAF-4D    | 45   | DAV-1    | 169    | DOM- 1I   | 46     | DOM-27D/25 | 49   |
| CRT-13G | 297  | DAI-1P    | 169  | DAV-1P   | 169    | DOM- 2D   | 47     | DOM-27D/26 | 49   |
| CRT-14G | 297  | DAI-2D    | 169  | DC-1D    | 52     | DOM- 3D   | 47     | DOM-27D/27 | 49   |
| CRT-15G | 297  | DAL-1P    | 168  | DC-2D    | 52     | DOM- 3I   | 47     | DOM-27D/28 | 49   |
| CRT-17G | 297  | DAR-1     | 169  | DC-3     | 52     | DOM- 4    | 47     | DOM-27D/29 | 49   |
| CRT-18G | 297  | DAT- 1D   | 218  | DC-4D    | 52     | DOM- 4D   | 47     | DOM-27D/30 | 49   |
| CSB-1D  | 31   | DAT- 1DP  | 218  | DEB- 1X  | 248    | DOM- 5D   | 47     | DOM-27D/31 | 49   |
| CSB-2D  | 31   | DAT- 1I   | 218  | DEB-12L  | 285    | DOM- 6D   | 47     | DOM-27D/32 | 49   |
| CT-1    | 224  | DAT- 1IP  | 218  | DEF-1D   | 45     | DOM- 6I   | 47     | DOM-27D/33 | 49   |
| CT-1P   | 224  | DAT- 2D   | 218  | DEK- 1G  | 302    | DOM- 7D   | 47     | DOM-27D/34 | 49   |
| CT-2    | 224  | DAT- 2DP  | 218  | DEK- 2   | 45     | DOM- 7I   | 47     | DOM-27D/35 | 49   |
| CT-2P   | 225  | DAT- 2I   | 218  | DEK- 3   | 45     | DOM- 8D   | 47     | DOM-27D/36 | 49   |
| CT-2P1  | 225  | DAT- 2IP  | 218  | DEK- 4   | 45     | DOM- 9    | 47-169 | DOM-27D/37 | 49   |
| CT-3    | 225  | DAT- 3D   | 218  | DEK- 6D  | 45     | DOM- 9D   | 47-169 | DOM-27D/38 | 49   |
| CT-3P   | 225  | DAT- 3I   | 218  | DEK- 7D  | 45     | DOM-10D   | 47     | DOM-27D/39 | 49   |
| CT-4P   | 225  | DAT- 4D   | 218  | DEK- 8   | 45     | DOM-11D   | 47     | DOM-27D/40 | 49   |
| CUB-1   | 44   | DAT- 4I   | 218  | DEK- 9D  | 45     | DOM-11I   | 47     | DOM-27D/41 | 49   |
| CVL-1D  | 44   | DAT- 5D   | 218  | DEK-10   | 45     | DOM-12    | 47     | DOM-27D/42 | 49   |
| CVL-1I  | 44   | DAT- 6    | 218  | DEK-11   | 45     | DOM-12D   | 47     | DOM-27D/43 | 49   |
| CVL-2D  | 44   | DAT- 6C1  | 219  | DEK-13   | 45     | DOM-13D   | 47     | DOM-27D/44 | 49   |
| CVL-2I  | 44   | DAT- 6D   | 218  | DEK-14D  | 45     | DOM-14D   | 47-170 | DOM-27D/45 | 49   |
| CVL-3D  | 44   | DAT- 6DP  | 219  | DIA-1    | 46     | DOM-15D   | 48     | DOM-27D/46 | 49   |
| CVL-3I  | 44   | DAT- 6DP1 | 219  | DIA-2    | 46     | DOM-16D   | 48     | DOM-27D/47 | 49   |
| CVL-4   | 44   | DAT- 6P   | 219  | DIA-3    | 46     | DOM-17I   | 48     | DOM-27D/48 | 49   |
| CVL-5D  | 44   | DAT- 6P1  | 219  | DIE-1    | 46-349 | DOM-18D   | 48     | DOM-27D/49 | 49   |
| CVL-5I  | 44   | DAT- 7    | 218  | DLC-1    | 46     | DOM-20D   | 48     | DOM-27D/50 | 49   |
| CVL-6   | 44   | DAT- 7P   | 219  | DLC-2    | 46     | DOM-21D   | 48     | DOM-27D/51 | 49   |
| CVL-8D  | 44   | DAT- 7P1  | 219  | DLC-3    | 46     | DOM-22    | 48     | DOM-27D/52 | 49   |
| CVL-9D  | 44   | DAT- 8    | 219  | DLP-1    | 45     | DOM-25D   | 48     | DOM-27D/53 | 49   |
|         |      | DAT- 8I   | 219  | DLP-2    | 46     | DOM-26    | 48     | DOM-27D/54 | 49   |
|         |      | DAT- 8IP  | 219  | DM-1     | 46     | DOM-26D   | 48     | DOM-27D/55 | 49   |
|         |      | DAT- 8IP1 | 219  | DMR-6-1  | 285    | DOM-27/12 | 48     | DOM-27D/56 | 49   |
|         |      | DAT- 8P   | 219  | DMR-6-1L | 285    | DOM-27/13 | 48     | DOM-27D/57 | 49   |

## D

# ÍNDICE GENERAL

## GENERAL INDEX

| REF.       | PAG.   |
|------------|--------|
| DOM-27D/58 | 49     |
| DOM-27D/59 | 49     |
| DOM-27D/60 | 49     |
| DOM-27D/61 | 49     |
| DOM-28     | 49     |
| DOM-28D    | 49     |
| DOM-29     | 49     |
| DOM-30     | 49     |
| DOM-31     | 49     |
| DOM-32     | 50     |
| DOM-33     | 50     |
| DOM-34     | 50     |
| DOM-35     | 50     |
| DOM-35D    | 50     |
| DOM-36     | 50     |
| DOM-36D    | 50     |
| DOM-37     | 50     |
| DOM-37D    | 50     |
| DOM-38D    | 50-170 |
| DOM-39     | 50     |
| DOM-40D    | 50     |
| DOM-41D    | 48     |
| DOM-42     | 50     |
| DOM-43     | 50     |
| DOM-44D    | 48     |
| DOM-45     | 48     |
| DOM-46D    | 48     |
| DOM-48     | 47     |
| DOM-49D    | 48     |
| DOM-51     | 50     |
| DOM-52     | 50     |
| DOM-53D    | 50     |
| DOM-54D    | 50     |
| DOM-55     | 51     |
| DOM-55D    | 51     |
| DOM-56D    | 51     |
| DOM-57     | 51     |
| DOM-57D    | 51     |
| DOM-58D    | 50     |
| DOM-59     | 51     |
| DOM-60D    | 51     |
| DOM-61     | 51     |
| DOM-62D    | 51     |
| DOM-63D    | 51     |
| DOM-64D    | 51     |
| DOM-65     | 51     |
| DOM-66D    | 51     |
| DOM-67D    | 51     |
| DOM-68     | 51     |
| DOM-71D    | 51     |
| DOM-72D    | 50     |
| DOM-73D    | 51     |
| DOM-74D    | 50     |
| DOM-B1     | 51     |
| DR-1       | 46     |
| DU-1       | 170    |
| DUP-1G     | 335    |
| DUR-1D     | 52     |
| DV- 1G     | 302    |
| DV- 2G     | 335    |

| REF.     | PAG. |
|----------|------|
| DV- 3G   | 302  |
| DV- 4G   | 335  |
| DV- 5G   | 302  |
| DV- 6G   | 302  |
| DV- 7G   | 302  |
| DV- 8G   | 302  |
| DV- 9G   | 302  |
| DV-10G   | 303  |
| DV-10G-A | 335  |
| DV-11G   | 335  |
| DV-12G   | 303  |
| DV-13G   | 303  |
| DV-13G-A | 336  |
| DV-14G   | 303  |
| DV-15G   | 303  |
| DV-16G   | 303  |
| DV-17G   | 336  |
| DV-18G   | 303  |
| DV-19G   | 303  |
| DX-5     | 46   |
| DX-5D    | 46   |
| DX-6     | 46   |
| DX-6D    | 46   |
| <b>E</b> |      |
| E-0G     | 343  |
| E-0G(CV) | 343  |
| E-1G     | 343  |
| E-1G(CV) | 343  |
| E-2G     | 344  |
| E-2G(CV) | 344  |
| E-3G     | 344  |
| E-3G(CV) | 344  |
| EAG-2D   | 52   |
| EC-1     | 52   |
| EC-1D    | 52   |
| ECH-1    | 170  |
| EG-1     | 52   |
| EG-2     | 52   |
| EI-1D    | 52   |
| EI-2D    | 52   |
| ELB-1G   | 303  |
| ELZ- 1D  | 53   |
| ELZ- 1G  | 304  |
| ELZ- 2   | 53   |
| ELZ- 2G  | 285  |
| ELZ- 3D  | 53   |
| ELZ- 3G  | 285  |
| ELZ- 4   | 53   |
| ELZ- 4D  | 53   |
| ELZ- 4G  | 304  |
| ELZ- 5D  | 53   |
| ELZ- 5G  | 286  |
| ELZ- 6D  | 53   |
| ELZ- 6G  | 286  |
| ELZ- 7G  | 304  |
| ELZ- 8D  | 53   |
| ELZ- 9   | 53   |
| ELZ-10   | 53   |
| ELZ-10D  | 53   |

| REF.     | PAG.   |
|----------|--------|
| ELZ-11D  | 53     |
| ELZ-12   | 53     |
| ELZ-12D  | 53     |
| EMK-1    | 53     |
| EP-1D    | 53     |
| ER-1D    | 53     |
| ER-1G    | 286    |
| ER-2D    | 53     |
| ER-3     | 54     |
| ER-4D    | 54     |
| ER-4G    | 286    |
| ER-5G    | 286    |
| ERV-1G   | 304    |
| ERV-2G   | 304    |
| ERV-3G   | 304    |
| ERV-3G-A | 336    |
| ES-1D    | 54     |
| ES-1G    | 286    |
| ES-1I    | 54     |
| ESL-1    | 54     |
| ESL-1D   | 54     |
| ESS-1    | 54     |
| ESS-2    | 54     |
| ESS-3    | 54     |
| ESS-4    | 54     |
| ESS-9D   | 54     |
| EST- 1G  | 304    |
| EST- 2G  | 304    |
| EST- 3G  | 305    |
| EST- 4G  | 305    |
| EST- 5G  | 305    |
| EST- 5TG | 305    |
| EST- 6G  | 305    |
| EST- 7G  | 305    |
| EST-10G  | 305    |
| ETS-1D   | 54     |
| EU- 1    | 54     |
| EU- 2    | 55     |
| EU- 3    | 55     |
| EU- 4    | 55     |
| EU- 4D   | 55     |
| EU- 6    | 54     |
| EU- 7    | 55     |
| EU- 7D   | 55     |
| EU- 8D   | 55     |
| EU- 9    | 54     |
| EU-10D   | 54     |
| EU-11    | 55     |
| EU-12    | 55-170 |
| EU-13D   | 55     |
| EU-14D   | 54     |
| EUB-1    | 54     |
| EUB-2    | 54     |
| EUR-1D   | 54     |
| EUT-1G   | 305    |
| EUT-2G   | 306    |
| EUT-3G   | 306    |
| EV- 1    | 55     |
| EV- 2    | 55     |
| EV- 2I   | 55     |

| REF.      | PAG. |
|-----------|------|
| EV- 3D    | 55   |
| EV- 3I    | 55   |
| EV- 4D    | 55   |
| EV- 6D    | 56   |
| EV- 7D    | 56   |
| EV- 8D    | 56   |
| EV- 9D    | 56   |
| EV-10     | 55   |
| EV-11     | 56   |
| EV-11D    | 56   |
| EV-12D    | 56   |
| EV-13D    | 55   |
| EV-19     | 56   |
| EV-20D    | 56   |
| EV-23D    | 56   |
| EV-24     | 56   |
| EV-25D    | 55   |
| EV-27D/ 1 | 56   |
| EV-27D/ 2 | 56   |
| EV-27D/ 3 | 56   |
| EV-27D/ 4 | 56   |
| EV-27D/ 5 | 56   |
| EV-27D/ 6 | 56   |
| EV-27D/ 7 | 56   |
| EV-27D/ 8 | 56   |
| EV-27D/ 9 | 56   |
| EV-27D/10 | 56   |
| EVE-1     | 55   |
| EVE-1D    | 55   |
| EVE-2D    | 55   |
| EVE-3D    | 55   |
| EVE-4     | 55   |
| EX-1D     | 56   |
| EXS-1D    | 56   |
| EXS-2D    | 56   |
| EXS-3     | 56   |
| EXS-3D    | 56   |
| EXS-4D    | 56   |
| EXS-5     | 56   |
| EXS-5D    | 56   |
| EXS-6     | 56   |
| EZ-1D     | 56   |
| EZ-1G     | 306  |
| EZ-1I     | 56   |
| EZ-2G     | 306  |
| EZ-2I     | 56   |
| EZ-3D     | 57   |
| EZ-3G     | 306  |
| EZ-3I     | 57   |
| EZ-4D     | 57   |
| EZ-4G     | 306  |
| EZ-4I     | 57   |
| EZ-5G     | 306  |
| EZ-6G     | 306  |
| EZ-7G     | 306  |
| EZ-8G     | 307  |
| EZ-DS10   | 57   |
| EZ-DS10E  | 57   |
| EZ-DS15   | 57   |
| EZ-DS15R  | 57   |

| REF.     | PAG. |
|----------|------|
| <b>F</b> |      |
| F1(L)    | 347  |
| FA-1     | 59   |
| FA-1D    | 59   |
| FA-1G    | 286  |
| FA-2G    | 286  |
| FA-2PPG  | 286  |
| FA-3G    | 287  |
| FA-3PPG  | 287  |
| FA-4G    | 287  |
| FA-5G    | 287  |
| FA-6G    | 287  |
| FA-7G    | 287  |
| FAB-1    | 170  |
| FAB-2    | 170  |
| FAC- 1D  | 58   |
| FAC- 1G  | 307  |
| FAC- 1I  | 58   |
| FAC- 2D  | 58   |
| FAC- 2G  | 307  |
| FAC- 2I  | 58   |
| FAC- 3D  | 58   |
| FAC- 3G  | 307  |
| FAC- 3I  | 58   |
| FAC- 4D  | 58   |
| FAC- 4G  | 307  |
| FAC- 5D  | 58   |
| FAC- 6D  | 58   |
| FAC- 7D  | 58   |
| FAC- 8D  | 58   |
| FAC- 9D  | 58   |
| FAC-10D  | 58   |
| FAC-11D  | 58   |
| FAC-12D  | 58   |
| FAC-13D  | 58   |
| FAC-14D  | 58   |
| FAC-15   | 58   |
| FAC-18   | 58   |
| FAC-19   | 58   |
| FAC-20D  | 58   |
| FAC-21   | 59   |
| FAC-21D  | 59   |
| FAC-22D  | 59   |
| FAC-23   | 59   |
| FAC-24   | 59   |
| FAI-A    | 171  |
| FAI-B    | 171  |
| FAI-C    | 171  |
| FAI-D    | 171  |
| FAIN-1I  | 59   |
| FAL-1D   | 59   |
| FAL-2D   | 59   |
| FAM-1    | 59   |
| FAM-2    | 59   |
| FAN-1    | 59   |
| FAN-1D   | 59   |
| FAR-1D   | 171  |
| FAR-1I   | 171  |
| FAR-2D   | 171  |

| REF.   | PAG. | REF.     | PAG. | REF.      | PAG.   | REF.      | PAG. | REF.     | PAG. |
|--------|------|----------|------|-----------|--------|-----------|------|----------|------|
| FAR-2I | 171  | FEM-3D   | 171  | FI-16P1   | 234    | FO -20D   | 173  | FTH- 9   | 63   |
| FAR-3  | 171  | FEM-3I   | 171  | FIA-1     | 171    | FO -22P   | 173  | FTH-10   | 63   |
| FAR-3D | 171  | FER-1    | 60   | FIA-2     | 171    | FO -24C1  | 187  | FTH-11D  | 63   |
| FAR-4D | 171  | FET-1G   | 307  | FIC- 1    | 61     | FO -24C2  | 188  | FTH-12D  | 64   |
| FAS-1  | 59   | FF- 1    | 60   | FIC- 2    | 61     | FO -35    | 173  | FTH-13D  | 64   |
| FAV-1D | 59   | FF- 1D   | 60   | FIC- 5    | 61     | FO -36    | 174  | FTH-14D  | 64   |
| FAV-2  | 59   | FF- 2    | 60   | FIC- 7    | 61     | FO -ANP   | 174  | FTH-15   | 64   |
| FAY-1D | 60   | FF- 2D   | 60   | FIC- 8    | 61     | FO -D     | 174  | FTH-16   | 64   |
| FAY-1X | 248  | FF- 3    | 60   | FIC- 9    | 61     | FO -E-TC  | 174  | FTH-17D  | 64   |
| FB- 1  | 57   | FF- 5D   | 60   | FIC- 18   | 61     | FO -E-TCP | 174  | FTH-18   | 64   |
| FB- 2D | 57   | FF- 6    | 61   | FIC-200   | 310    | FO -FHP   | 174  | FTH-19   | 64   |
| FB- 2I | 57   | FF- 7D   | 61   | FIC-401G  | 287    | FO -FK    | 174  | FTH-20D  | 64   |
| FB- 3  | 57   | FF- 8D   | 61   | FIS-1D    | 62-171 | FO -FKP   | 174  | FTH-21   | 63   |
| FB- 4  | 57   | FF- 9D   | 61   | FLO-1     | 62     | FO -FR    | 174  | FTH-22   | 63   |
| FB- 5  | 57   | FF-10D   | 60   | FLO-1D    | 62     | FO -FRP   | 174  | FTH-23   | 64   |
| FB- 6  | 57   | FF-11    | 61   | FLO-2D    | 171    | FO -OA    | 174  | FTH-25   | 64   |
| FB- 7  | 57   | FF-13    | 61   | FM- 1G    | 308    | FO -OL    | 174  | FTH-26D  | 64   |
| FB- 8  | 57   | FI- 1    | 179  | FM- 1X    | 248    | FO -OR    | 174  | FTH-27   | 65   |
| FB- 9  | 57   | FI- 1P   | 179  | FM- 2G    | 308    | FO -PN    | 174  | FTH-28   | 65   |
| FB-10  | 57   | FI- 1P8  | 179  | FM- 2X    | 248    | FO -PRL   | 174  | FTH-29   | 65   |
| FB-11  | 57   | FI- 2D   | 179  | FM- 3G    | 308    | FO -PRR   | 174  | FTH-31   | 65   |
| FB-12  | 57   | FI- 2DP3 | 179  | FM- 4G    | 308    | FO -SR    | 188  | FV-1D    | 60   |
| FB-13  | 57   | FI- 3    | 179  | FM- 4TG   | 308    | FO -TC    | 174  |          |      |
| FB-14  | 57   | FI- 3D   | 179  | FM- 5G    | 308    | FO -TX    | 175  |          |      |
| FB-15  | 57   | FI- 3DP  | 179  | FM- 6G    | 308    | FO -TX1   | 175  | <b>G</b> |      |
| FB-16  | 57   | FI- 3DP1 | 179  | FM- 7G    | 308    | FO -TX1P  | 175  | GAB-1D   | 65   |
| FB-17  | 57   | FI- 3DP2 | 179  | FM- 8G    | 309    | FO -TX2   | 175  | GAB-1I   | 65   |
| FB-18  | 57   | FI- 3DP3 | 179  | FM-13G    | 309    | FO -TX2P  | 175  | GAB-2    | 65   |
| FB-19  | 57   | FI- 3DP4 | 180  | FM-14G    | 309    | FO -TXP   | 175  | GARD-1G  | 310  |
| FB-20  | 57   | FI- 3DP5 | 180  | FM-15G    | 309    | FO -XL    | 174  | GAS- 1   | 175  |
| FB-21  | 57   | FI- 4D   | 180  | FM-16G    | 309    | FO -XR    | 174  | GAS- 1D  | 175  |
| FB-22  | 57   | FI- 5D   | 180  | FM-17G    | 309    | FON-1E    | 62   | GAT-1    | 65   |
| FB-23  | 57   | FI- 5I   | 180  | FM-20G    | 309    | FON-2E    | 62   | GAT-2D   | 65   |
| FB-24  | 57   | FI- 6I   | 180  | FM-21G    | 309    | FON-3E    | 62   | GAT-3D   | 65   |
| FB-25  | 57   | FI- 6IP  | 180  | FO - 1    | 171    | FON-4E    | 62   | GBZ-1    | 65   |
| FB-26  | 57   | FI- 6IP1 | 180  | FO - 2    | 172    | FON-5E    | 62   | GDA- 1P  | 67   |
| FB-27  | 57   | FI- 6IP2 | 180  | FO - 3    | 171    | FON-6E    | 62   | GDA- 3D  | 67   |
| FB-28  | 57   | FI- 6IP3 | 180  | FO - 3D   | 171    | FON-6E    | 62   | GDA-30D  | 67   |
| FB-29  | 57   | FI- 6IP4 | 179  | FO - 3DP  | 172    | FORTIS-2I | 63   | GDA-50D  | 67   |
| FB-31  | 57   | FI- 7I   | 180  | FO - 3P   | 172    | FR- 1D    | 62   | GDA-60D  | 67   |
| FB-32  | 57   | FI- 8I   | 180  | FO - 4P   | 172    | FR- 2     | 62   | GE- 1D   | 65   |
| FB-33  | 57   | FI- 8IP  | 180  | FO - 5    | 165    | FR- 4     | 62   | GE- 2    | 65   |
| FB-34  | 57   | FI- 8IP1 | 180  | FO - 6P   | 172    | FR- 7D    | 62   | GE- 3D   | 66   |
| FB-35  | 57   | FI- 9I   | 181  | FO - 7P   | 172    | FR- 8     | 62   | GE- 4D   | 66   |
| FB-38  | 57   | FI- 9IP  | 181  | FO - 8    | 172    | FR- 9D    | 62   | GE- 5    | 66   |
| FB-39  | 57   | FI-10    | 179  | FO - 8D   | 172    | FR-11D    | 62   | GE- 5D   | 66   |
| FB-41  | 57   | FI-10P   | 179  | FO - 8DP  | 172    | FRI-1X    | 249  | GE- 6    | 66   |
| FCS-1D | 61   | FI-11    | 181  | FO - 8DP1 | 172    | FRI-2X    | 249  | GE- 6D   | 66   |
| FEB-1G | 307  | FI-11P   | 181  | FO - 9D   | 172    | FRI-3     | 63   | GE- 7    | 66   |
| FEB-2G | 307  | FI-12    | 179  | FO - 9DP  | 172    | FTE - 1   | 62   | GE- 8    | 66   |
| FEC-1D | 60   | FI-12P   | 179  | FO - 10P  | 172    | FTE - 1D  | 62   | GE- 9    | 66   |
| FEC-2  | 60   | FI-12P1  | 179  | FO -10D   | 172    | FTH- 1    | 63   | GE-10D   | 66   |
| FEC-3D | 60   | FI-12P3  | 179  | FO -11D   | 172    | FTH- 1D   | 63   | GE-11    | 66   |
| FED-1  | 60   | FI-13    | 181  | FO -12    | 173    | FTH- 2    | 63   | GE-15D   | 66   |
| FED-2  | 60   | FI-13P   | 181  | FO -12P   | 173    | FTH- 3    | 63   | GE-16D   | 66   |
| FED-3  | 60   | FI-13P1  | 181  | FO -13DP  | 173    | FTH- 4    | 63   | GE-19    | 66   |
| FEM-1D | 171  | FI-13P7  | 181  | FO -14DP  | 173    | FTH- 5    | 63   | GE-21    | 66   |
| FEM-1I | 171  | FI-14P   | 181  | FO -15D   | 173    | FTH- 6    | 63   | GE-21D   | 66   |
| FEM-2D | 171  | FI-15    | 181  | FO -15DP  | 173    | FTH- 7    | 63   | GEA-1    | 66   |
| FEM-2I | 171  | FI-16C1  | 234  | FO -17P   | 173    | FTH- 8    | 63   | GEA-1X   | 249  |
|        |      |          |      | FO -18D   | 173    | FTH- 8D   | 63   | GEA-2D   | 66   |

# ÍNDICE GENERAL

## GENERAL INDEX

| REF.     | PAG. | REF.      | PAG. | REF.     | PAG. | REF.       | PAG. | REF.       | PAG. |
|----------|------|-----------|------|----------|------|------------|------|------------|------|
| GEA-3    | 66   | GM - 4P1  | 176  | GMT-3D   | 65   | HAW-1D     | 71   | HOND-16DP1 | 184  |
| GEA-3X   | 249  | GM - 5    | 176  | GMT-4D   | 65   | HAW-2D     | 71   | HOND-17P   | 184  |
| GEA-4D   | 67   | GM - 5P   | 176  | GMT-5D   | 65   | HAW-3D     | 71   | HOND-18DP  | 183  |
| GEA-5D   | 67   | GM - 6    | 176  | GOD-1    | 69   | HAW-4D     | 71   | HOND-18P   | 183  |
| GEA-6D   | 67   | GM - 6P   | 176  | GOD-2    | 69   | HB-1       | 71   | HOND-19    | 184  |
| GEA-7D   | 67   | GM - 7    | 176  | GPS-1G   | 310  | HD-1       | 182  | HOND-19D   | 184  |
| GEA-8D   | 67   | GM - 7P   | 176  | GPS-2G   | 310  | HD-1D      | 182  | HOND-19DP  | 184  |
| GEB-1D   | 66   | GM - 8    | 176  | GPZ-1G   | 287  | HD-2       | 182  | HOND-19P   | 184  |
| GG-1D    | 169  | GM - 8P   | 176  | GR-1D    | 70   | HD-2D      | 182  | HOND-20    | 184  |
| GH-1     | 178  | GM - 9    | 176  | GR-1I    | 70   | HD-3       | 182  | HOND-20D   | 184  |
| GH-2     | 178  | GM - 9P   | 176  | GR-2D    | 70   | HD-3D      | 182  | HOND-20DP  | 184  |
| GH-3     | 178  | GM - 10   | 176  | GR-2I    | 70   | HD-4D      | 182  | HOND-20P   | 184  |
| GH-GX    | 178  | GM - 10P  | 176  | GR-3D    | 70   | HEK-1      | 71   | HOND-22DP  | 184  |
| GH-HX    | 178  | GM - 11   | 176  | GR-3I    | 70   | HEK-2      | 71   | HOND-23    | 184  |
| GH-PS    | 178  | GM - 11P  | 176  | GR-4D    | 70   | HEK-3      | 71   | HOND-24DP  | 184  |
| GIB-1D   | 67   | GM - 12   | 176  | GR-4I    | 70   | HEK-4      | 71   | HOND-24P   | 184  |
| GIM-1TG  | 310  | GM - 12P  | 176  | GR-5D    | 70   | HEL-1      | 71   | HOND-25P2  | 182  |
| GIOB-1D  | 181  | GM - 13   | 176  | GR-5I    | 70   | HEN-1      | 71   | HOND-26DP1 | 185  |
| GIOB-1DP | 181  | GM - 13P  | 176  | GR-6     | 70   | HEN-1D     | 71   | HOND-26P1  | 185  |
| GIOB-2I  | 181  | GM - 14   | 176  | GR-6D    | 70   | HEN-1GP    | 288  | HOND-27D   | 185  |
| GIOB-2IP | 181  | GM - 14P  | 176  | GR-7     | 70   | HEN-2      | 71   | HOND-28DP  | 185  |
| GIOB-3P  | 182  | GM - 15D  | 176  | GR-7D    | 70   | HOB-1      | 72   | HOND-28P   | 185  |
| GIOB-3P2 | 182  | GM - 15DP | 176  | GR-8     | 70   | HOB-2D     | 72   | HOND-29DP  | 185  |
| GIU-1    | 67   | GM - 16P  | 177  | GRG-1    | 69   | HOND- 1    | 182  | HOND-29P   | 185  |
| GIU-1D   | 67   | GM - 17P  | 177  | GTV- 1D  | 69   | HOND- 1P   | 182  | HOND-30DP2 | 182  |
| GIU-2    | 67   | GM - 18P  | 177  | GTV- 2   | 69   | HOND- 2    | 182  | HOND-30P2  | 182  |
| GIU-2D   | 67   | GM - 19P  | 177  | GTV- 2D  | 69   | HOND- 2P   | 182  | HOND-31P   | 185  |
| GIU-3D   | 67   | GM - 20P  | 177  | GTV- 3D  | 69   | HOND- 3D   | 182  | HOND-42P   | 185  |
| GIU-4    | 68   | GM - 21   | 177  | GTV- 4D  | 69   | HOND- 3I   | 182  | HOND-43    | 185  |
| GLA-1D   | 68   | GM - 21P  | 177  | GTV- 5D  | 69   | HOND- 4D   | 182  | HOND-43D   | 185  |
| GLA-2D   | 68   | GM - 22   | 177  | GTV-10   | 69   | HOND- 4DP  | 182  | HOND-43DP  | 185  |
| GLO- 1D  | 68   | GM - 22P  | 177  | GTV-11   | 69   | HOND- 4DP1 | 183  | HOND-43P   | 185  |
| GLO- 1I  | 68   | GM - 23   | 177  | GUA-1    | 69   | HOND- 4DP2 | 182  | HOND-45D   | 185  |
| GLO- 2   | 68   | GM - 23P  | 177  | GUA-1D   | 69   | HOND- 4I   | 182  | HOND-46D   | 185  |
| GLO- 2D  | 68   | GM - 24   | 177  | GUA-2    | 69   | HOND- 4IP  | 182  | HOND-49    | 185  |
| GLO- 3   | 68   | GM - 24P  | 177  | GUA-2D   | 69   | HOND- 4IP1 | 183  | HOR-1      | 72   |
| GLO- 3D  | 68   | GM - 25   | 177  | GUA-3    | 70   | HOND- 5D   | 183  | HOR-2      | 72   |
| GLO- 4D  | 68   | GM - 25P  | 177  | GUA-3D   | 70   | HOND- 5I   | 183  | HOR-2D     | 72   |
| GLO- 4I  | 68   | GM - 26   | 178  | GUR-1G   | 288  | HOND- 6D   | 183  | HRM-1      | 71   |
| GLO- 5I  | 68   | GM - 42   | 178  | GW-1D    | 178  | HOND- 6I   | 183  | HT-1       | 72   |
| GLO- 6   | 68   | GM -A     | 178  | <b>H</b> |      | HOND- 7D   | 183  | HTE -1D    | 72   |
| GLO- 6D  | 68   | GM -AP    | 178  | H-3G     | 344  | HOND- 7I   | 183  | HTE -50    | 72   |
| GLO- 7   | 68   | GM -B     | 178  | H-3G(CV) | 344  | HOND- 8D   | 183  | HU -1      | 188  |
| GLO- 7D  | 68   | GM -BP    | 178  | HA-1D    | 182  | HOND- 8I   | 183  | HU -2P     | 188  |
| GLO- 8   | 68   | GM -C     | 178  | HA-1I    | 182  | HOND- 9D   | 183  | HU -3      | 188  |
| GLO- 8D  | 68   | GM -CP    | 178  | HAF-1    | 70   | HOND- 9I   | 183  | HU -AN     | 188  |
| GLO- 9D  | 68   | GM -D     | 178  | HAF-1D   | 70   | HOND-10    | 183  | HU -DF     | 188  |
| GLO-10   | 69   | GM -DP    | 178  | HAF-2    | 70   | HOND-10P   | 183  | HU -DFP    | 188  |
| GLO-11   | 69   | GM -E     | 178  | HAF-2D   | 70   | HOND-11    | 183  | HU -DFP1   | 188  |
| GLO-12D  | 69   | GM -EP    | 178  | HAF-3D   | 70   | HOND-11P   | 183  | HU -DHP    | 188  |
| GLO-22   | 69   | GM -H     | 178  | HAF-4    | 70   | HOND-12    | 183  | HU -DNP    | 188  |
| GLO-22D  | 69   | GM -HP    | 178  | HAG-1D   | 70   | HOND-12P   | 183  | HU -HAAC1  | 188  |
| GLO-23   | 69   | GM -J     | 178  | HAK-1D   | 71   | HOND-13    | 183  | HU -HAAC2  | 189  |
| GLO-23D  | 69   | GM -JP    | 178  | HAK-2D   | 71   | HOND-13P   | 183  | HU -HAAC3  | 236  |
| GM - 1P  | 175  | GM -K     | 178  | HAK-3    | 71   | HOND-14    | 183  | HU -HAAC4  | 236  |
| GM - 2   | 175  | GM -KP    | 178  | HAK-4    | 71   | HOND-14P   | 183  | HU -HAAC5  | 189  |
| GM - 2P  | 175  | GMG-1G    | 310  | HAK-5    | 71   | HOND-15    | 183  | HU -HAAP1  | 189  |
| GM - 3P  | 175  | GMG-2G    | 310  | HAL-1    | 70   | HOND-15P   | 184  | HU -MN     | 189  |
| GM - 4   | 175  | GMT-1     | 65   | HAR-1I   | 71   | HOND-16D   | 184  | HU -MNP    | 189  |
| GM - 4P  | 176  | GMT-2     | 65   |          |      | HOND-16DP  | 184  | HU -NAAC2  | 189  |

| REF.     | PAG.   | REF.      | PAG. | REF.     | PAG. | REF.    | PAG. | REF.     | PAG. |
|----------|--------|-----------|------|----------|------|---------|------|----------|------|
| HU-NW    | 189    | IF-11     | 73   | ING-D    | 78   | JAR-4D  | 80   | JUNI-6D  | 82   |
| HU-P     | 189    | IF-2      | 73   | ING-M    | 78   | JAR-5D  | 80   | JUNI-7D  | 82   |
| HU-SC    | 189    | IF-3P     | 73   | ING-N    | 78   | JAR-5I  | 80   | JUNI-8D  | 82   |
| HU-SR    | 189    | IF-4      | 73   | ING-S    | 78   | JAR-6   | 79   | JUNI-9D  | 82   |
| HU-SU    | 189    | IF-5      | 73   | ING-W    | 78   | JAR-6D  | 79   | JUZU-1   | 82   |
| HU-SX    | 189    | IF-6      | 74   | INT-1    | 78   | JAU-1P  | 229  | JV-1D    | 82   |
| HU-SY    | 189    | IF-15     | 74   | INT-1D   | 78   | JD-1    | 199  | JV-1I    | 82   |
| HU-SZ    | 189    | IF-35     | 74   | IR-1P    | 78   | JD-2    | 199  | JV-2     | 82   |
| HUD-1    | 185    | IF-45-55  | 74   | IS-1D    | 78   | JD-3D   | 199  | JV-3D    | 82   |
| HUD-1D   | 185    | IF-60-70  | 74   | IS-1G    | 311  | JD-4D   | 199  | JV-3I    | 82   |
| HUD-2D   | 72-185 | IF-D20    | 74   | IS-1I    | 78   | JGH-1D  | 82   | JV-4I    | 82   |
| HUD-3    | 72     | IF-D25    | 74   | IS-1X    | 249  | JIN-1D  | 80   | JV-5I    | 82   |
| HUN-1D   | 72     | IF-D30    | 74   | IS-2D    | 78   | JIP-1D  | 80   | JV-6     | 82   |
| HUW-1    | 72-196 | IF-I20    | 74   | IS-2G    | 311  | JIP-1I  | 80   | JV-7     | 82   |
| HUW-1D   | 72-196 | IF-I25    | 74   | IS-2I    | 78   | JIS-1D  | 80   | JV-7D    | 82   |
| HUW-2    | 72     | IF-I30    | 74   | IS-3D    | 78   | JIS-2I  | 80   | JW-20G   | 313  |
| HUW-3D   | 72     | IF-I40    | 74   | IS-3G    | 311  | JIS-3D  | 80   | JW-30G   | 313  |
| HUW-N    | 73-196 | IF-I40L   | 74   | IS-3I    | 78   | JIS-3I  | 80   | JW-40G   | 313  |
| HY-1     | 196    | IF-I50    | 74   | IS-4     | 78   | JIS-4P  | 80   | JW-45G   | 313  |
| HY-2     | 196    | IF-I51    | 74   | IS-4G    | 312  | JMA-1D  | 146  | JW-50G   | 313  |
| HY-2P    | 196    | IF-I60-70 | 74   | IS-5D    | 78   | JMA-1I  | 146  | JW-70G   | 313  |
| HY-3     | 196    | IGS-1     | 74   | IS-5G    | 312  | JMA-2D  | 146  | JW-90G   | 313  |
| HY-3D    | 196    | IL-1D     | 77   | IS-6D    | 78   | JMA-2I  | 146  | JWL-1D   | 80   |
| HY-3DP   | 196    | IL-1I     | 77   | IS-6G    | 312  | JMA-3D  | 146  | JWL-2D   | 80   |
| HY-3DP1  | 196    | IL-2      | 77   | IS-7D    | 78   | JMA-3I  | 146  | JWL-3D   | 80   |
| HY-3DP2  | 196    | ILC-1D    | 77   | IS-8     | 78   | JMA-4D  | 146  | JWL-4D   | 80   |
| HY-3P2   | 196    | ILC-2D    | 77   | IS-8D    | 78   | JMA-4I  | 146  | JWL-5    | 81   |
| HY-3P3   | 196    | ILC-3     | 77   | IS-10    | 79   | JMA-9D  | 146  | JWL-6    | 81   |
| HY-4     | 197    | ILC-6D    | 77   | IS-10P   | 79   | JMA-9I  | 146  | JWL-7D   | 81   |
| HY-4P    | 197    | ILL-1     | 77   | IS-14D   | 79   | JNG-1   | 82   | JWL-9    | 80   |
| HY-4P2   | 197    | ILL-2     | 77   | IS-15    | 79   | JNG-1D  | 82   | JWL-9D   | 80   |
| HY-4P3   | 197    | ILL-2D    | 77   | IS-16D   | 79   | JNG-2D  | 82   | JWL-10D  | 81   |
| HY-5     | 197    | ILS-1     | 77   | IS-17D   | 79   | JNG-3   | 82   | JWL-11D  | 81   |
| HY-5P    | 197    | IMB-1     | 77   | IS-18D   | 78   | JO-1    | 80   |          |      |
| HY-6D    | 197    | IMB-1D    | 77   | IS-19D   | 78   | JOM-1D  | 80   | <b>K</b> |      |
| HY-6DP   | 197    | IMS-3     | 224  | IS-20    | 79   | JPM-1D  | 81   | KA-1     | 82   |
| HY-7P    | 197    | IMS-3C    | 198  | ISU-1    | 199  | JPM-1E  | 81   | KA-2     | 82   |
| HY-8     | 197    | IMS-3P    | 224  | ISU-2    | 199  | JPM-1I  | 81   | KA-3     | 82   |
| HY-8P    | 197    | IMS-5     | 224  | ISU-3D   | 199  | JPM-2D  | 81   | KA-4     | 82   |
| HY-9P2   | 197    | IMS-5C    | 198  | ISU-3DP  | 199  | JPM-2E  | 81   | KA-5     | 83   |
| HY-11DP1 | 198    | IMS-5P    | 224  | IT-1G    | 312  | JPM-2I  | 81   | KA-6     | 83   |
| HY-11DP3 | 198    | IMS-6D    | 198  | IT-1TG   | 312  | JPM-3D  | 81   | KA-7     | 82   |
| HY-11P3  | 198    | IMS-6I    | 198  | IT-2G    | 312  | JPM-4   | 81   | KA-8     | 83   |
| HY-12P3  | 198    | IMS-7     | 198  | IT-3G    | 312  | JPM-4D  | 81   | KA-10    | 83   |
|          |        | IMS-7P    | 198  | IT-4G    | 312  | JPM-10D | 81   | KA-11    | 83   |
|          |        | IMS-8     | 198  | ITO-1D   | 79   | JPM-11D | 81   | KAB-1D   | 83   |
|          |        | IMS-9     | 198  | ITO-2D   | 79   | JTF-1I  | 81   | KAE-1    | 83   |
|          |        | IMS-10    | 198  | IV-1     | 79   | JTF-2I  | 81   | KAE-1G   | 313  |
|          |        | IMS-11P   | 198  | IV-2D    | 79   | JTF-3   | 81   | KAE-2    | 83   |
|          |        | IMS-12    | 198  |          |      | JTF-4   | 81   | KAE-3    | 83   |
|          |        | IMS-13    | 224  | <b>J</b> |      | JU-1    | 82   | KAE-3D   | 83   |
|          |        | IMS-13P   | 224  | J-1G(CV) | 344  | JU-2    | 82   | KAE-4    | 83   |
|          |        | IMS-MER   | 199  | J-2G(CV) | 344  | JU-2D   | 82   | KAE-5    | 83   |
|          |        | IN-1      | 234  | J-3G     | 344  | JUNI-1  | 82   | KAE-6    | 83   |
|          |        | IN-4      | 234  | J-3G(CV) | 344  | JUNI-1D | 82   | KAE-6D   | 83   |
|          |        | IN-5      | 234  | JAR-1D   | 79   | JUNI-2  | 82   | KAE-7    | 83   |
|          |        | INCE-1E   | 78   | JAR-1I   | 79   | JUNI-2D | 82   | KAE-7D   | 83   |
|          |        | INCE-2E   | 78   | JAR-2D   | 79   | JUNI-3D | 82   | KAE-8    | 84   |
|          |        | ING-6     | 78   | JAR-2I   | 79   | JUNI-4D | 82   | KAE-8D   | 84   |
|          |        | ING-A     | 78   | JAR-3    | 79   | JUNI-5D | 82   | KAE-9    | 84   |



# ÍNDICE GENERAL

## GENERAL INDEX

| REF.    | PAG. | REF.     | PAG. | REF.     | PAG.   | REF.    | PAG.   | REF.    | PAG.   |
|---------|------|----------|------|----------|--------|---------|--------|---------|--------|
| KAE-9D  | 84   | KI-2D    | 201  | LAP-3D   | 87     | LAS-TK  | 88-202 | LF-24   | 94     |
| KAE-10D | 84   | KI-3DP   | 201  | LAP-3E   | 87     | LAS-TX  | 89-202 | LF-25   | 94     |
| KAE-11D | 84   | KI-3P    | 201  | LAP-3I   | 87     | LAS-U   | 88-202 | LF-26   | 94     |
| KAE-12D | 84   | KIC-1    | 85   | LAP-4    | 87     | LAS-V   | 89-202 | LF-27   | 94     |
| KAE-13D | 84   | KIF-1    | 85   | LAP-5D   | 87     | LAS-X   | 88-202 | LF-28   | 94-204 |
| KAE-14  | 84   | KIF-1D   | 85   | LAP-6    | 87     | LAS-XS  | 89-202 | LF-29D  | 94     |
| KAL-1   | 84   | KIF-2D   | 85   | LAP-7D   | 87     | LAS-XY  | 89-202 | LF-30   | 94     |
| KAL-2D  | 84   | KIR-1D   | 86   | LAP-8D   | 87     | LAS-Y   | 89-202 | LF-31   | 95     |
| KAM-1   | 199  | KIR-2    | 86   | LAP-9    | 87     | LASB-1  | 89     | LF-32   | 93-203 |
| KAM-1D  | 199  | KNA-1D   | 86   | LAP-9D   | 87     | LASB-1D | 89     | LF-33D  | 94     |
| KAP-1D  | 84   | KOM-1    | 201  | LAP-10D  | 87     | LASB-1G | 288    | LF-34   | 95     |
| KAP-2D  | 84   | KP-1     | 86   | LAP-11D  | 87     | LASB-2  | 89     | LF-35   | 95     |
| KAS-1G  | 314  | KR-1X    | 250  | LAP-13P  | 87     | LASB-2D | 89     | LF-36   | 95     |
| KAS-2G  | 314  | KR-2X    | 250  | LAP-17P  | 87     | LASB-2G | 288    | LF-37D  | 95     |
| KAS-4G  | 314  | KR-3X    | 250  | LAP-20P  | 87     | LASB-3D | 89     | LF-38D  | 95     |
| KAS-6G  | 314  | KR-4X    | 250  | LAP-21P  | 87     | LASB-3G | 288    | LF-39D  | 204    |
| KAW-1D  | 199  | KR-5X    | 250  | LAP-22P  | 87     | LASB-4G | 288    | LF-40   | 94     |
| KAW-1I  | 199  | KR-6X    | 250  | LAP-23P  | 87     | LB-1    | 91     | LF-41   | 95     |
| KAW-2D  | 199  | KR-7X    | 250  | LAP-28D  | 87     | LB-1D   | 91     | LF-43   | 94     |
| KAW-2I  | 199  | KR-8X    | 250  | LAP-29D  | 87     | LB-2D   | 92     | LF-44   | 95     |
| KAW-3   | 199  | KR-9X    | 251  | LAP-30D  | 87     | LB-2DP  | 92     | LF-45   | 95     |
| KAW-4   | 200  | KR-10X   | 251  | LAP-34D  | 87     | LB-3    | 92     | LF-46   | 95     |
| KAW-5   | 200  | KR-11X   | 251  | LAP-42D  | 88     | LB-3D   | 92     | LF-BL   | 204    |
| KAW-5P  | 200  | KR-12X   | 251  | LAP-43D  | 88     | LB-4D   | 92     | LF-RO   | 204    |
| KAW-6DP | 200  | KR-13X   | 251  | LAP-44D  | 88     | LCK-1X  | 252    | LF-ROP  | 204    |
| KAW-6P  | 200  | KR-14X   | 251  | LAP-45D  | 88     | LEA-1D  | 89     | LF-SL   | 204    |
| KAW-7P  | 200  | KR-15X   | 251  | LAP-46D  | 88     | LEA-2D  | 89     | LF-SLP  | 204    |
| KAW-8   | 200  | KR-16X   | 251  | LAP-88   | 88     | LEG-1D  | 89     | LF-WB   | 204    |
| KAW-8D  | 200  | KR-17X   | 252  | LAP-96D  | 88     | LF-1D   | 92-203 | LF-WBP  | 205    |
| KAW-9P  | 200  | KRA-1D   | 86   | LAR-1G   | 288    | LF-1I   | 92-203 | LF-WR   | 205    |
| KAW-10P | 200  | KRA-2    | 86   | LAR-1I   | 88     | LF-2    | 93-203 | LIN-1D  | 89     |
| KAZ-1   | 84   | KRE-1D   | 86   | LAR-2G   | 332    | LF-3    | 203    | LIN-1I  | 89     |
| KAZ-2   | 84   | KRP-1G   | 315  | LAR-3G   | 332    | LF-4I   | 93-203 | LIN-2   | 89     |
| KAZ-3   | 84   | KUR-1G   | 315  | LAS-1D   | 88-202 | LF-5    | 93-203 | LIN-2G  | 315    |
| KAZ-4   | 84   | KWI-1    | 86   | LAS-2    | 88-202 | LF-5D   | 93-203 | LIN-3D  | 89     |
| KAZ-5   | 84   | KWI-2D   | 86   | LAS-3    | 88-202 | LF-6    | 203    | LIN-3G  | 315    |
| KAZ-5D  | 84   | KYM-1DP  | 201  | LAS-4    | 88-202 | LF-7    | 93-203 | LIN-3I  | 89     |
| KAZ-6   | 85   | KYM-1P   | 201  | LAS-4D   | 88-202 | LF-7D   | 93-203 | LIN-4D  | 89     |
| KAZ-7   | 85   | KYM-2    | 201  | LAS-5    | 88-202 | LF-8    | 93-204 | LIN-4I  | 89     |
| KE-1    | 85   | KYM-2D   | 201  | LAS-5D   | 88-202 | LF-8D   | 93-204 | LIN-5D  | 90     |
| KE-3    | 85   | KYM-2DP  | 201  | LAS-6    | 88-202 | LF-9    | 204    | LIN-5I  | 90     |
| KE-4    | 85   | KYM-2P   | 201  | LAS-6D   | 88-202 | LF-10   | 93     | LIN-6D  | 90     |
| KE-5    | 85   | KYM-3P   | 201  | LAS-7    | 88     | LF-11   | 93-204 | LIN-6I  | 90     |
| KEN-1   | 200  | KYM-3DP  | 201  | LAS-8    | 88     | LF-11D  | 93-204 | LIN-7D  | 90     |
| KEN-1D  | 200  |          |      | LAS-9    | 88     | LF-12   | 93-203 | LIN-7I  | 90     |
| KFV-1   | 85   | <b>L</b> |      | LAS-10   | 89     | LF-12D  | 93-203 | LIN-8D  | 90     |
| KFV-1X  | 249  | L-3G     | 344  | LAS-11   | 89     | LF-13   | 93     | LIN-8I  | 90     |
| KFV-2X  | 249  | L-3G(CV) | 344  | LAS-11D  | 89     | LF-13D  | 93     | LIN-9   | 90     |
| KFV-3X  | 249  | LA-1D    | 201  | LAS-12D  | 89     | LF-14D  | 93     | LIN-10D | 90     |
| KFV-C   | 85   | LA-1DP   | 201  | LAS-AX   | 88-202 | LF-15   | 93-204 | LIN-10I | 90     |
| KFV-D   | 85   | LA-2     | 201  | LAS-AX-L | 89     | LF-15D  | 93-204 | LIN-11D | 90     |
| KFV-E   | 85   | LA-2P    | 201  | LAS-BT   | 202    | LF-16   | 93     | LIN-11I | 90     |
| KFV-F   | 85   | LA-3D    | 201  | LAS-CR   | 202    | LF-17   | 93-204 | LIN-12D | 90     |
| KFV-L   | 85   | LA-3DP   | 201  | LAS-FH   | 88-202 | LF-18D  | 93     | LIN-12I | 90     |
| KFV-M   | 85   | LA-4D    | 202  | LAS-KT   | 88-202 | LF-19   | 94     | LIN-13  | 90     |
| KFV-N   | 85   | LA-4DP   | 202  | LAS-P    | 202    | LF-20   | 94     | LIN-14D | 89     |
| KFV-O   | 85   | LAF-1D   | 86   | LAS-R    | 89-202 | LF-20D  | 94     | LIN-14I | 89     |
| KI-1D   | 200  | LAP-1    | 86   | LAS-RC   | 202    | LF-21   | 94     | LIN-15D | 89     |
| KI-1DP  | 200  | LAP-2D   | 86   | LAS-SX   | 89-202 | LF-22   | 94     | LIN-15I | 89     |
| KI-1DP1 | 200  | LAP-2E   | 86   | LAS-TB   | 202    | LF-23   | 94     | LIN-16  | 90     |

| REF.     | PAG. | REF.     | PAG. | REF.      | PAG. | REF.     | PAG. | REF.     | PAG. |
|----------|------|----------|------|-----------|------|----------|------|----------|------|
| LIN-16D  | 90   | LWO- 2   | 92   | MAZ- 6DP  | 206  | MCM-32D  | 99   | MER-13I  | 100  |
| LIN-17   | 90   | LWO- 2D  | 92   | MAZ- 6P   | 206  | MCM-33   | 99   | MER-14I  | 100  |
| LIN-17D  | 90   | LWO- 7D  | 92   | MAZ- 7D   | 206  | MCM-35   | 99   | MER-15   | 100  |
| LIN-18   | 90   | LWO- 8   | 92   | MAZ- 7DP  | 206  | ME - 1   | 189  | MER-16   | 100  |
| LIN-18D  | 90   | LWO- 9   | 92   | MAZ- 7DP1 | 206  | ME - 1P  | 189  | MER-16D  | 100  |
| LIN-19D  | 90   | LWO-26D  | 92   | MAZ- 8D   | 206  | ME - 2P  | 190  | MER-17   | 100  |
| LIN-20D  | 89   | LYF-1T   | 96   | MAZ- 8DP  | 206  | ME - 3P  | 190  | MER-18   | 100  |
| LIN-21D  | 90   | LYF-2T   | 96   | MAZ-11D   | 206  | ME - 4P  | 190  | MER-19D  | 101  |
| LIN-25   | 90   |          |      | MAZ-11DP1 | 206  | ME - 5P  | 190  | MER-20D  | 101  |
| LIN-25D  | 90   | <b>M</b> |      | MAZ-13D   | 206  | ME - 6P  | 190  | MER-21D  | 101  |
| LIP- 1D  | 90   | MA-5D    | 96   | MAZ-13DP  | 206  | ME - 7P  | 190  | MERI-1D  | 207  |
| LIP- 1GD | 91   | MAC-1G   | 336  | MAZ-13DP1 | 207  | ME - 8P  | 190  | MERI-1DP | 207  |
| LIP- 1I  | 90   | MAG-2DP  | 96   | MAZ-14D   | 207  | ME - 9P  | 190  | MET-2D   | 101  |
| LIP- 2   | 91   | MAK-1    | 205  | MAZ-15D   | 207  | ME -10P  | 190  | MEZ-1D   | 101  |
| LIP- 2D  | 91   | MAR-1P   | 205  | MAZ-16    | 207  | ME -11P  | 190  | MG-6D    | 40   |
| LIP- 3   | 91   | MAS - 1  | 96   | MAZ-21DP1 | 207  | ME -12P  | 190  | MG-6I    | 40   |
| LIP- 4   | 91   | MAS - 1D | 96   | MBL-1     | 103  | ME -13DP | 190  | MG-6S    | 40   |
| LIP-28D  | 91   | MAS - 2D | 96   | MBL-1D    | 103  | ME -14P  | 190  | MG-9     | 40   |
| LIP-33   | 91   | MAS - 3D | 96   | MCH-1     | 101  | ME -HD   | 191  | MGA-1    | 101  |
| LIT-1I   | 91   | MAS - 4D | 96   | MCH-1D    | 101  | ME -HDP  | 191  | MGA-1D   | 101  |
| LIT-2D   | 91   | MAS - 5D | 96   | MCH-2     | 101  | ME -HF   | 191  | MGA-2    | 101  |
| LIT-2GD  | 91   | MAS - 6  | 96   | MCH-2D    | 101  | ME -HFP  | 191  | MGA-3    | 101  |
| LIT-3D   | 91   | MAS - 7  | 96   | MCL-1D    | 97   | ME -HM   | 191  | MI-1D    | 101  |
| LIT-5D   | 91   | MAS - 7D | 96   | MCM- 1    | 97   | ME -HMLP | 191  | MI-2D    | 101  |
| LIT-5I   | 91   | MAS - 8  | 96   | MCM- 1G   | 288  | ME -HMP  | 191  | MI-3D    | 102  |
| LIT-7D   | 91   | MAS - 9  | 97   | MCM- 2D   | 97   | ME -HU   | 191  | MI-4D    | 102  |
| LMP-1    | 202  | MAS - 9D | 97   | MCM- 2G   | 315  | ME -HUP  | 191  | MI-5D    | 102  |
| LMP-1P   | 202  | MAS -10  | 97   | MCM- 2I   | 97   | ME -HY   | 191  | MIL-1    | 102  |
| LMP-2    | 203  | MAS -10D | 97   | MCM- 3D   | 98   | ME -HYP  | 191  | MIL-2    | 102  |
| LMP-2P   | 203  | MAS -11  | 96   | MCM- 3G   | 315  | ME -HZ   | 191  | MIN-1D   | 102  |
| LMP-3    | 203  | MAS -11D | 96   | MCM- 3I   | 98   | ME -HZP  | 191  | MIS-1    | 207  |
| LMP-3P   | 203  | MAS -12D | 96   | MCM- 4D   | 98   | ME -L    | 191  | MIT- 1D  | 207  |
| LMP-4    | 203  | MAS -13D | 97   | MCM- 4EC  | 98   | ME -NU   | 191  | MIT- 1DP | 207  |
| LMP-4P   | 203  | MAS -15P | 97   | MCM- 4G   | 289  | ME -NUP  | 191  | MIT- 1I  | 207  |
| LMP-4P1  | 203  | MAS -17  | 97   | MCM- 4I   | 98   | ME -NY   | 191  | MIT- 1IP | 207  |
| LMP-5    | 203  | MAS -17D | 97   | MCM- 4SS  | 98   | ME -NYP  | 191  | MIT- 2D  | 207  |
| LMP-5P   | 203  | MAS -18D | 97   | MCM- 5D   | 98   | ME -S    | 191  | MIT- 2DP | 207  |
| LMP-5P1  | 203  | MAS -19  | 97   | MCM- 5G   | 315  | ME -SP   | 192  | MIT- 2I  | 207  |
| LO-1D    | 92   | MAS -22D | 96   | MCM- 5I   | 98   | ME -VA   | 192  | MIT- 2IP | 207  |
| LO-1I    | 92   | MAS -24D | 96   | MCM- 6    | 98   | MEC-5D   | 99   | MIT- 3   | 208  |
| LO-2D    | 92   | MAS -29D | 97   | MCM- 7    | 98   | MEL-1    | 99   | MIT- 3P  | 208  |
| LO-2I    | 92   | MASL-1   | 97   | MCM- 8    | 98   | MEL-2D   | 100  | MIT- 4   | 208  |
| LO-3D    | 92   | MAX-1G   | 336  | MCM-10    | 98   | MEL-3    | 100  | MIT- 4P  | 208  |
| LO-4D    | 92   | MAX-2G   | 336  | MCM-11S   | 98   | MEL-4    | 99   | MIT- 5   | 208  |
| LOC-1D   | 92   | MAZ- 1D  | 205  | MCM-12D   | 98   | MEL-4D   | 99   | MIT- 5P  | 208  |
| LPO- 1   | 88   | MAZ- 1I  | 205  | MCM-13D   | 98   | MEL-5P   | 100  | MIT- 6   | 208  |
| LPO- 2   | 88   | MAZ- 2D  | 205  | MCM-16    | 98   | MER- 1D  | 100  | MIT- 6P  | 208  |
| LT-1     | 95   | MAZ- 2DP | 205  | MCM-18D   | 98   | MER- 1T  | 100  | MIT- 7   | 208  |
| LUC-1D   | 95   | MAZ- 2I  | 205  | MCM-21D   | 98   | MER- 2I  | 100  | MIT- 7P  | 208  |
| LUC-2    | 95   | MAZ- 2IP | 205  | MCM-24B   | 99   | MER- 3I  | 100  | MIT- 8D  | 208  |
| LUMA-1D  | 95   | MAZ- 3D  | 205  | MCM-24C   | 99   | MER- 3T  | 100  | MIT- 8DP | 208  |
| LUMA-1I  | 95   | MAZ- 3DP | 205  | MCM-24D   | 99   | MER- 4I  | 100  | MIT- 9   | 209  |
| LUMA-2D  | 95   | MAZ- 3I  | 205  | MCM-24E   | 99   | MER- 5I  | 100  | MIT-10   | 209  |
| LUMA-2I  | 95   | MAZ- 3IP | 205  | MCM-24F   | 99   | MER- 6I  | 100  | MIT-11D  | 209  |
| LUMA-3D  | 95   | MAZ- 4   | 205  | MCM-26    | 99   | MER- 7I  | 100  | MIT-12   | 209  |
| LUMA-3I  | 95   | MAZ- 4P  | 205  | MCM-27    | 99   | MER- 8I  | 100  | MIT-13D  | 209  |
| LUMA-4D  | 95   | MAZ- 5D  | 205  | MCM-29D   | 99   | MER- 9I  | 100  | MIT-14D  | 209  |
| LUMA-4I  | 95   | MAZ- 5DP | 206  | MCM-30D   | 99   | MER-10I  | 100  | MIT-15P  | 208  |
| LWO- 1   | 92   | MAZ- 6   | 206  | MCM-31    | 99   | MER-11I  | 100  | MIW-1    | 102  |
| LWO- 1D  | 92   | MAZ- 6D  | 206  | MCM-31D   | 99   | MER-12I  | 100  | MIW-2    | 102  |

# ÍNDICE GENERAL

## GENERAL INDEX

| REF.     | PAG. | REF.      | PAG. | REF.     | PAG. | REF.     | PAG. | REF.    | PAG. |
|----------|------|-----------|------|----------|------|----------|------|---------|------|
| MIW-3    | 102  | MT-14G    | 319  | NE-10    | 211  | NE-39P   | 215  | OJ- 9D  | 106  |
| MIW-4    | 102  | MT-15G    | 319  | NE-10P   | 211  | NE-40    | 215  | OJ-10   | 106  |
| MLM-1D   | 102  | MT-16G    | 319  | NE-11    | 211  | NE-40P   | 215  | OJ-11   | 106  |
| MLM-2    | 102  | MT-17PG   | 319  | NE-11P   | 211  | NE-41P   | 216  | OJ-12   | 106  |
| MLM-3    | 103  | MT-18G    | 319  | NE-11P1  | 211  | NE-42    | 216  | OJ-13   | 106  |
| MLM-4    | 103  | MT-AG     | 104  | NE-11P2  | 211  | NE-42P   | 216  | OJ-14   | 106  |
| MLM-5    | 102  | MT-AGP    | 104  | NE-11P3  | 212  | NE-42P1  | 216  | OJ-15   | 106  |
| MLM-5D   | 102  | MT-CG     | 104  | NE-12    | 212  | NE-43    | 216  | OJ-16   | 106  |
| MLM-6    | 103  | MT-CGP    | 104  | NE-12P   | 212  | NE-44P   | 214  | OJ-17   | 106  |
| MLM-7    | 103  | MT-DGP    | 104  | NE-13    | 212  | NE-45    | 216  | OJ-18P  | 106  |
| MM-1X    | 252  | MT-EG     | 104  | NE-14    | 212  | NE-45P   | 216  | OJ-19   | 106  |
| MNO-1D   | 103  | MT-EGP    | 104  | NE-15D   | 210  | NE-46    | 216  | OJ-J    | 106  |
| MOD-1DP  | 209  | MT-GG     | 104  | NE-15DP  | 210  | NE-47    | 216  | OJ-K    | 106  |
| MOG-1D   | 103  | MT-GGP    | 104  | NE-15DP1 | 210  | NE-48    | 216  | OJ-L    | 106  |
| MOI-1G   | 316  | MTL-1     | 101  | NE-15I   | 210  | NE-49    | 216  | OJ-M    | 106  |
| MOI-2G   | 316  | MTL-1D    | 101  | NE-15IP  | 210  | NE-50P   | 216  | OJ-Q    | 106  |
| MOI-3G   | 316  | MTL-1G    | 315  | NE-15IP1 | 210  | NE-51P2  | 217  | OL-5D   | 106  |
| MOK-1G   | 289  | MTL-2G    | 316  | NE-16    | 212  | NE-52P   | 217  | OLIV-1  | 107  |
| MON-1D   | 103  | MTO-1     | 101  | NE-18    | 212  | NE-53    | 217  | OM-1    | 107  |
| MON-1I   | 103  | MUL-T 2P  | 104  | NE-18P   | 212  | NE-54P   | 217  | OMC-1D  | 107  |
| MON-2D   | 103  | MUL-T 3P  | 104  | NE-19    | 212  | NE-55P   | 217  | OMC-1G  | 319  |
| MON-2I   | 103  | MUL-T 3P1 | 104  | NE-19P   | 212  | NE-56    | 217  | OMC-2D  | 107  |
| MOR-1X   | 252  | MUL-T 4P  | 104  | NE-19P1  | 212  | NE-57    | 217  | OMC-3   | 107  |
| MOR-2X   | 252  | MUL-T 5P  | 104  | NE-20    | 212  | NE-58D   | 217  | OMC-4   | 107  |
| MOS-1    | 209  | MUL-T 6   | 105  | NE-20P   | 212  | NE-59P   | 217  | OMC-5D  | 107  |
| MP-1D    | 104  | MUL-T 6D  | 105  | NE-20P1  | 212  | NE-60C1  | 217  | OMC-6D  | 107  |
| MP-1I    | 104  | MUL-T 7P  | 104  | NE-20P2  | 213  | NE-60C2  | 217  | OMI-1   | 107  |
| MPA-1G   | 289  | MUL-T 8P1 | 104  | NE-20P3  | 213  | NE-61D   | 218  | OMI-1D  | 107  |
| MQ-1D    | 96   | MUL-T 9P1 | 104  | NE-22P   | 213  | NE-62    | 218  | ON-1D   | 107  |
| MQ-1I    | 96   | MUL-T10P  | 105  | NE-22P1  | 213  | NE-63D   | 218  | ON-1I   | 107  |
| MR-1     | 103  | MUL-T11P1 | 104  | NE-22P2  | 213  | NEF-1X   | 253  | OP- 1   | 192  |
| MR-2     | 103  | MUL-T16P  | 105  | NE-23    | 213  | NEF-2Z 1 | 340  | OP- 6   | 192  |
| MR-3     | 103  | MXS-1     | 97   | NE-24    | 213  | NEF-2Z 2 | 340  | OP- 7   | 192  |
| MSM-1D   | 104  |           |      | NE-24P   | 213  | NEF-2Z 3 | 340  | OP- 8   | 192  |
| MSM-2D   | 104  |           |      | NE-24P1  | 213  | NEF-2Z 4 | 340  | OP- 9   | 192  |
| MSV-1    | 104  | <b>N</b>  |      | NE-25    | 213  | NEF-2Z 5 | 340  | OP-11C1 | 192  |
| MSV-1X   | 252  | N-1G      | 345  | NE-26    | 213  | NEF-2Z 6 | 340  | OP-AB   | 192  |
| MSV-2    | 104  | N-1G NIQ  | 345  | NE-27    | 213  | NEF-2Z 7 | 340  | OP-ABP  | 192  |
| MT- 1G   | 316  | NAB-1X    | 252  | NE-28    | 213  | NEF-2Z 8 | 340  | OP-BA   | 192  |
| MT- 2G   | 316  | NE- 1     | 209  | NE-28    | 213  | NEF-2Z 9 | 340  | OP-BAP  | 192  |
| MT- 2TG  | 316  | NE- 1D    | 209  | NE-29    | 214  | NEF-2Z10 | 340  | OP-BB   | 192  |
| MT- 3G   | 316  | NE- 1DP   | 209  | NE-29P   | 214  | NO-1     | 105  | OP-CC   | 192  |
| MT- 3P1G | 317  | NE- 1P    | 209  | NE-30    | 214  | NTC-10D  | 105  | OP-D    | 192  |
| MT- 3PG  | 317  | NE- 2     | 209  | NE-30P   | 214  | NTC-6    | 105  | OP-DD   | 192  |
| MT- 4G   | 317  | NE- 3     | 210  | NE-31    | 214  |          |      | OP-DP   | 192  |
| MT- 5G   | 317  | NE- 3D    | 210  | NE-31P   | 214  |          |      | OP-EE   | 192  |
| MT- 5P1G | 317  | NE- 3P    | 210  | NE-32    | 214  | <b>O</b> |      | OP-FF   | 192  |
| MT- 6G   | 317  | NE- 3P1   | 210  | NE-32P   | 214  | OA-1     | 107  | OP-HA   | 193  |
| MT- 6P1G | 318  | NE- 3P2   | 210  | NE-33P   | 214  | OCA-1D   | 105  | OP-HB   | 193  |
| MT- 6PG  | 318  | NE- 4     | 210  | NE-33P1  | 214  | OCA-2D   | 105  | OP-HG   | 193  |
| MT- 8G   | 318  | NE- 4D    | 210  | NE-34P   | 214  | OF-1     | 105  | OP-HH   | 193  |
| MT- 8P1G | 318  | NE- 4P    | 210  | NE-35    | 214  | OF-2     | 105  | OP-J    | 193  |
| MT- 8PG  | 318  | NE- 4P1   | 210  | NE-35P   | 215  | OJ- 1D   | 105  | OP-JP   | 193  |
| MT- 9G   | 318  | NE- 4P2   | 210  | NE-35P2  | 215  | OJ- 2I   | 105  | OP-NA   | 193  |
| MT- 9P1G | 318  | NE- 5     | 210  | NE-36    | 215  | OJ- 3D   | 105  | OP-NB   | 193  |
| MT- 9PG  | 318  | NE- 6     | 211  | NE-36P   | 215  | OJ- 3I   | 105  | OP-R    | 193  |
| MT-10G   | 317  | NE- 6P    | 211  | NE-36P1  | 215  | OJ- 4D   | 106  | OP-RP   | 193  |
| MT-10P1G | 318  | NE- 7     | 211  | NE-37    | 215  | OJ- 5I   | 106  | OP-S    | 192  |
| MT-10PG  | 318  | NE- 8     | 211  | NE-37P   | 215  | OJ- 6D   | 106  | OP-SP   | 192  |
| MT-11G   | 318  | NE- 9     | 211  | NE-38    | 215  | OJ- 6I   | 106  | OP-SP1  | 193  |
|          |      | NE- 9P    | 211  | NE-38P1  | 215  | OJ- 7I   | 105  |         |      |

| REF.    | PAG. |
|---------|------|
| OP-T    | 193  |
| OP-TP   | 193  |
| OP-WHC1 | 193  |
| OP-WHP  | 193  |
| OP-WYP  | 193  |
| OR-0G   | 333  |
| OR-1G   | 333  |
| OR-1I   | 107  |
| OR-2G   | 319  |
| OR-3G   | 289  |
| OR-4G   | 333  |
| OR-5G   | 333  |
| OR-6G   | 289  |
| ORK-1D  | 108  |
| ORO-1D  | 108  |
| OST-1G  | 289  |
| OST-2G  | 289  |

## P

|         |     |
|---------|-----|
| PAD-1D  | 108 |
| PAD-2D  | 108 |
| PAD-3   | 108 |
| PAD-3D  | 108 |
| PAP-1   | 108 |
| PAP-1X  | 253 |
| PAP-2   | 108 |
| PAP-2X  | 253 |
| PAP-3   | 108 |
| PAP-4   | 108 |
| PAP-5   | 108 |
| PAP-6   | 108 |
| PAT-1G  | 319 |
| PC-1D   | 109 |
| PC-1T   | 109 |
| PC-2D   | 109 |
| PC-3TP  | 109 |
| PCI-1T  | 108 |
| PEN-1   | 109 |
| PEN-1D  | 109 |
| PEN-2   | 109 |
| PET-1   | 109 |
| PEU-1C1 | 236 |
| PEU-2C1 | 236 |
| PFA- 1  | 109 |
| PFA- 2  | 109 |
| PFA- 3  | 109 |
| PFA- 4  | 109 |
| PFA- 5  | 109 |
| PFA- 6  | 110 |
| PFA- 6D | 110 |
| PFA- 7D | 110 |
| PFA- 8D | 110 |
| PFA- 9D | 110 |
| PFA-10D | 109 |
| PFA-11D | 109 |
| PFA-12D | 109 |
| PFA-13D | 109 |
| PFA-14D | 109 |
| PFA-15D | 109 |
| PFA-16D | 109 |

| REF.     | PAG. |
|----------|------|
| PFA-17D  | 109  |
| PFA-18D  | 109  |
| PFA-21   | 110  |
| PFA-22   | 109  |
| PFA-22D  | 109  |
| PGO-1    | 221  |
| PGO-2P   | 221  |
| PHI-52   | 110  |
| PHO-1    | 110  |
| PIC-1E   | 110  |
| PIC-8D   | 110  |
| PJ-1     | 221  |
| PJ-2     | 221  |
| PJ-2P    | 221  |
| PJ-3     | 221  |
| PJ-K     | 221  |
| PJ-KP    | 222  |
| PLL-1    | 222  |
| PO -1P   | 193  |
| PO -2P   | 194  |
| PO -HC   | 194  |
| PO -HCP  | 194  |
| PO -NC   | 194  |
| PO -NCP  | 194  |
| POL-3TEC | 110  |
| POL-4E   | 110  |
| POL-5TEC | 110  |
| POS-1DP  | 222  |
| PPT-1G   | 289  |
| PPT-2G   | 289  |
| PPT-3G   | 289  |
| PR- 1    | 110  |
| PR- 1D   | 110  |
| PR- 1G   | 321  |
| PR- 2    | 110  |
| PR- 2G   | 336  |
| PR- 3    | 110  |
| PR- 3G   | 321  |
| PR- 4D   | 110  |
| PR- 4G   | 321  |
| PR- 4I   | 110  |
| PR- 5D   | 111  |
| PR- 5I   | 111  |
| PR- 6    | 111  |
| PR- 7    | 111  |
| PR- 8    | 111  |
| PR- 9    | 111  |
| PR- 9D   | 111  |
| PR-10    | 110  |
| PR-11    | 110  |
| PR-12    | 111  |
| PR-13    | 111  |
| PR-14    | 111  |
| PR-15D   | 111  |
| PR-16    | 111  |
| PR-16D   | 111  |
| PR-17D   | 111  |
| PR-18    | 111  |
| PR-19    | 111  |
| PR-20    | 111  |

| REF.     | PAG. |
|----------|------|
| PR-20D   | 111  |
| PRE-1I   | 222  |
| PRE-2I   | 222  |
| PRE-3    | 222  |
| PTN- 1D  | 110  |
| PTN- 1G  | 320  |
| PTN- 2D  | 110  |
| PTN- 2G  | 320  |
| PTN- 3G  | 320  |
| PTN- 4G  | 320  |
| PTN- 5G  | 320  |
| PTN- 6G  | 320  |
| PTN- 7G  | 320  |
| PTN-10G  | 320  |
| PTN-11G  | 321  |
| PTN-13G  | 321  |
| PTN-13TG | 321  |
| PTN-14G  | 321  |
| PTN-15G  | 321  |

## R

|         |         |
|---------|---------|
| RAZ-1D  | 112     |
| RE-1    | 111     |
| RE-1D   | 111     |
| RE-2    | 111     |
| RE-2D   | 111     |
| RE-3D   | 112     |
| RE-4D   | 111     |
| RE-5D   | 112     |
| REG-1D  | 111     |
| REN-1G  | 290     |
| REN-2G  | 290     |
| REVI-1G | 321     |
| REX-1D  | 112     |
| REX-1G  | 290     |
| REX-2G  | 290     |
| RGL-1G  | 322     |
| RGM -1D | 112     |
| RGM -1I | 112     |
| RGM -2  | 112     |
| RI-1D   | 112     |
| RI-1I   | 112     |
| RI-2D   | 112     |
| RI-2I   | 112     |
| RI-3D   | 112     |
| RI-3I   | 112     |
| RIG-1D  | 112     |
| RIO-1D  | 112     |
| RIT-1D  | 112     |
| RO- 1D  | 113-222 |
| RO- 1DS | 222     |
| RO- 1I  | 113-222 |
| RO- 1IS | 222     |
| RO- 1X  | 252     |
| RO- 2D  | 113-222 |
| RO- 2I  | 113-222 |
| RO- 3   | 222     |
| RO- 4D  | 113-222 |
| RO- 4I  | 113-222 |
| RO- 5D  | 113-222 |

| REF.    | PAG.    |
|---------|---------|
| RO- 5I  | 113-222 |
| RO- 6D  | 113-222 |
| RO- 6I  | 113-222 |
| RO- 7D  | 113-222 |
| RO- 7I  | 113-222 |
| RO- 8D  | 113-222 |
| RO- 8I  | 113-222 |
| RO- 9D  | 113     |
| RO- 9I  | 113     |
| RO-10D  | 113     |
| RO-10I  | 113     |
| RO-11D  | 113-222 |
| RO-11I  | 113-222 |
| RO-12D  | 114-223 |
| RO-12I  | 114-223 |
| RO-14   | 223     |
| RO-15   | 223     |
| RO-16D  | 114-223 |
| RO-16I  | 114-223 |
| RO-17   | 223     |
| RO-18I  | 113     |
| RO-19D  | 113     |
| RO-19I  | 113     |
| RO-20D  | 113     |
| RO-20I  | 113     |
| RO-21D  | 113     |
| RO-21I  | 113     |
| RO-22I  | 113     |
| RO-23D  | 113     |
| RO-24D  | 114     |
| RO-24I  | 114     |
| RO-25D  | 114     |
| RO-25I  | 114     |
| RO-26D  | 114     |
| RO-26I  | 114     |
| RO-27D  | 114     |
| RO-27I  | 114     |
| RO-28D  | 114     |
| RO-28I  | 114     |
| RO-29D  | 114     |
| RO-30   | 113-222 |
| RO-30D  | 113-222 |
| RO-31D  | 114     |
| RO-32D  | 113-222 |
| RO-33   | 113-222 |
| RO-34D  | 114     |
| RO-36D  | 114     |
| RO-37   | 114     |
| RO-37D  | 114     |
| RO-38   | 114     |
| RO-38D  | 114     |
| RO-39   | 114     |
| RO-40   | 114     |
| RO-40D  | 114     |
| RO-41   | 114     |
| RO-42   | 114     |
| ROS-1D  | 223     |
| ROS-2   | 223     |
| ROSE -1 | 114     |
| ROY-1   | 114     |

| REF.    | PAG. |
|---------|------|
| RSS-1   | 115  |
| RSS-2D  | 115  |
| RST-1   | 25   |
| RU - 1D | 114  |
| RU - 2D | 114  |
| RU - 2I | 114  |
| RU - 3D | 114  |
| RU - 4D | 114  |
| RU - 5D | 115  |
| RU - 5I | 115  |
| RU - 6I | 115  |
| RU - 7D | 115  |
| RU - 8D | 115  |
| RU - 9D | 115  |
| RU - 9I | 115  |
| RU -10D | 114  |
| RU -11D | 115  |
| RU -12D | 115  |
| RU -13D | 115  |
| RU -14D | 115  |
| RU -15  | 115  |
| RU -16D | 115  |
| RU -19D | 114  |
| RU -GC  | 115  |
| RU -GK  | 115  |
| RU -GK7 | 115  |
| RU -GL  | 115  |
| RU -GL7 | 115  |
| RU -GM  | 115  |
| RU -GM7 | 115  |
| RU -GS  | 115  |
| RU -GS7 | 115  |
| RU -K   | 115  |
| RU -KD  | 115  |
| RU -L   | 115  |
| RU -M   | 115  |
| RU -TL  | 114  |
| RUB-1G  | 322  |
| RUB-2G  | 322  |
| RUB-3G  | 336  |
| RUB-4G  | 322  |
| RUB-5G  | 322  |
| RUB-6G  | 333  |
| RUB-7G  | 322  |
| RUB-8G  | 322  |
| RUB-9G  | 322  |
| RUE-2G  | 333  |
| RUS-1   | 115  |
| RUS-2   | 115  |

## S

|         |     |
|---------|-----|
| SA-1    | 116 |
| SA-1D   | 116 |
| SA-2    | 116 |
| SA-3D   | 116 |
| SA-3I   | 116 |
| SA-4    | 116 |
| SAA-1P  | 223 |
| SAA-1P1 | 223 |
| SAA-2P  | 223 |

# ÍNDICE GENERAL

## GENERAL INDEX

| REF.    | PAG. | REF.     | PAG. | REF.    | PAG. | REF.    | PAG.    | REF.      | PAG. |
|---------|------|----------|------|---------|------|---------|---------|-----------|------|
| SAA-AC  | 223  | SI-1D    | 226  | SLG-3   | 117  | SR-4    | 125     | STS-13D   | 124  |
| SAA-ACP | 223  | SI-2D    | 226  | SLG-4   | 117  | SR-5    | 125     | STS-21D   | 124  |
| SABT-1  | 116  | SI-3     | 226  | SLG-5   | 117  | SRM-1G  | 324     | STS-28    | 123  |
| SAF-1G  | 323  | SI-3D    | 226  | SLG-6   | 117  | SSA-1P1 | 226     | STS-35    | 124  |
| SAF-2G  | 323  | SI-4     | 226  | SLG-7   | 117  | SSO-1   | 120     | STS-38    | 124  |
| SAG-1T  | 135  | SI-4D    | 226  | SLG-8   | 117  | SSO-2   | 120     | STS-B1    | 124  |
| SAM-1D  | 116  | SI-5D    | 226  | SLG-9   | 117  | ST-1I   | 122     | STS-T14   | 124  |
| SAM-1G  | 323  | SIA-2G   | 324  | SLG-10  | 117  | ST-2    | 122     | STS-TV 3  | 124  |
| SAM-2D  | 116  | SIA-3G   | 324  | SLG-11  | 117  | STA-1   | 122     | STS-TV 5  | 124  |
| SAM-2G  | 323  | SIB-1G   | 337  | SLG-12  | 117  | STA-1D  | 122     | STS-TV 8  | 124  |
| SAM-4G  | 323  | SIB-2G   | 324  | SLG-13  | 117  | STA-2   | 122     | STS-TV 9  | 124  |
| SAM-5G  | 323  | SIB-3G   | 325  | SLG-14  | 117  | STA-2D  | 122     | STS-X5    | 124  |
| SAR-1   | 116  | SIB-4G   | 325  | SLG-15  | 117  | STA-3   | 122     | STS-X6    | 124  |
| SAR-1D  | 116  | SIB-5G   | 325  | SLG-16  | 117  | STA-3D  | 122     | STUV-1D   | 124  |
| SAR-2D  | 116  | SID-1    | 119  | SLG-17  | 117  | STA-4   | 122     | STUV-1I   | 124  |
| SAR-3D  | 116  | SID-2    | 119  | SLG-18  | 117  | STA-4D  | 122     | STUV-2    | 125  |
| SAR-4   | 116  | SIM-900  | 167  | SLG-19  | 117  | STA-5   | 122     | STUV-3    | 124  |
| SAR-4D  | 116  | SIM-1200 | 160  | SLG-20  | 117  | STA-5D  | 122     | SUB-2P    | 227  |
| SAR-5D  | 116  | SIP-1    | 226  | SLG-21  | 117  | STB-1   | 124     | SUZU-1D   | 227  |
| SAR-6   | 116  | SIP-2    | 226  | SLG-22  | 117  | STB-1D  | 124     | SUZU-1I   | 227  |
| SAR-6D  | 116  | SIP-3    | 226  | SLG-23  | 117  | STE-1   | 123     | SUZU-2D   | 227  |
| SAT-1D  | 117  | SIS-1    | 119  | SLG-24  | 117  | STE-2D  | 123     | SUZU-2I   | 227  |
| SAT-2   | 117  | SIS-2    | 119  | SLG-25  | 117  | STE-3   | 123     | SUZU-3I   | 227  |
| SB-1PG  | 323  | SIS-3    | 119  | SM-1    | 119  | STE-4   | 123     | SUZU-4D   | 227  |
| SCC-1D  | 117  | SIS-4D   | 119  | SM-2    | 119  | STE-5D  | 123     | SUZU-4DP  | 227  |
| SCH-1D  | 117  | SIS-5D   | 119  | SM-3    | 119  | STE-6   | 123     | SUZU-4I   | 227  |
| SCO-1   | 18   | SIS-6    | 119  | SM-3D   | 119  | STE-7   | 123     | SUZU-4IP  | 227  |
| SCR-1   | 118  | SIS-6D   | 119  | SM-4    | 119  | STE-8D  | 123     | SUZU-5    | 227  |
| SDR-1G  | 325  | SIS-7D   | 119  | SM-4D   | 119  | STE-9D  | 123     | SUZU-5P   | 228  |
| SDR-2G  | 325  | SIS-8    | 120  | SOF-1   | 120  | STE-10  | 123     | SUZU-6    | 228  |
| SDR-3G  | 325  | SIS-8D   | 120  | SOF-2   | 120  | STE-11  | 123     | SUZU-7    | 228  |
| SE-AHP  | 194  | SIS-9    | 120  | SOFI-1D | 120  | STE-12  | 123     | SUZU-7DP  | 228  |
| SE-AN   | 194  | SIS-9D   | 120  | SOFI-1I | 120  | STE-13D | 123     | SUZU-7P   | 228  |
| SEA-1   | 117  | SIX-1    | 225  | SOFI-2D | 120  | STE-14D | 123     | SUZU-8    | 228  |
| SEA-2   | 118  | SIX-1P   | 225  | SOFI-2I | 120  | STF-1   | 124     | SUZU-8I   | 228  |
| SEC-1   | 118  | SIX-1P1  | 225  | SOFI-3I | 120  | STF-1D  | 124     | SUZU-8P   | 228  |
| SEC-1G  | 323  | SIX-1P2  | 225  | SOFI-4  | 120  | STG-1   | 123     | SUZU-9P   | 228  |
| SEC-2   | 118  | SIX-2    | 225  | SOFI-4D | 120  | STK-1   | 122     | SUZU-10   | 228  |
| SEC-2G  | 324  | SIX-2P   | 225  | SOFI-5  | 120  | STL-1D  | 122     | SUZU-10P  | 228  |
| SEC-3   | 118  | SIX-2P2  | 225  | SOFI-6  | 120  | STL-2I  | 122     | SUZU-11D  | 228  |
| SEC-3G  | 324  | SIX-3P   | 225  | SOL-1   | 120  | STR-1   | 123     | SUZU-11DP | 228  |
| SEC-4G  | 324  | SIX-3P1  | 225  | SOP-1D  | 120  | STR-2   | 123     | SUZU-12DP | 228  |
| SEC-7G  | 324  | SIX-3P2  | 225  | SOS-1D  | 121  | STR-3   | 227     | SUZU-13DP | 229  |
| SEL-1D  | 118  | SIX-4    | 225  | SOS-2D  | 121  | STR-4   | 123-227 | SUZU-13P  | 229  |
| SEL-1I  | 118  | SIX-4P   | 225  | SOS-3   | 121  | STR-5   | 123     | SUZU-14P2 | 229  |
| SEL-2D  | 118  | SIX-5P   | 226  | SOS-4D  | 121  | STS-1D  | 123     |           |      |
| SEL-2I  | 118  | SJL-1    | 120  | SOS-5   | 121  | STS-1DP | 123     | <b>T</b>  |      |
| SEL-3D  | 118  | SKO-1    | 170  | SPI-1   | 121  | STS-1I  | 123     | TAI-1     | 125  |
| SEL-4D  | 118  | SKO-1P   | 170  | SPI-1D  | 121  | STS-2D  | 227     | TAL-1     | 125  |
| SEN-1D  | 118  | SKO-2    | 170  | SQ-1    | 121  | STS-2DP | 227     | TAL-1D    | 125  |
| SEN-2D  | 118  | SKO-3I   | 170  | SQ-2    | 121  | STS-3D  | 123     | TAL-2     | 125  |
| SER-1G  | 337  | SKO-3IP  | 170  | SQ-3D   | 121  | STS-3I  | 123     | TAL-3     | 125  |
| SER-3D  | 118  | SKO-4    | 170  | SQ-4    | 121  | STS-4D  | 123     | TAP-1P    | 229  |
| SH-1I   | 119  | SKO-5P   | 171  | SQ-5D   | 121  | STS-4DP | 123     | TAP-2     | 229  |
| SHA-1   | 119  | SKO-6    | 171  | SQ-6    | 121  | STS-5D  | 227     | TAT-1D    | 229  |
| SHI-1   | 119  | SKO-7    | 171  | SQ-7    | 122  | STS-5DP | 227     | TAT-1DP   | 229  |
| SHI-1D  | 119  | SKO-8    | 171  | SQ-8D   | 122  | STS-6D  | 123     | TAT-2D    | 229  |
| SHI-2D  | 119  | SL-1     | 118  | SR-1I   | 125  | STS-7D  | 124     | TAT-2DP   | 229  |
| SHI-3D  | 119  | SLG-1    | 117  | SR-2    | 125  | STS-11  | 227     | TAY-1     | 126  |
| SHR-1   | 117  | SLG-2    | 117  | SR-3    | 125  | STS-12D | 124     | TC-1      | 126  |

| REF.        | PAG. | REF.    | PAG. | REF.      | PAG. | REF.       | PAG. | REF.    | PAG.    |
|-------------|------|---------|------|-----------|------|------------|------|---------|---------|
| TC-2        | 126  | TIT-12D | 129  | TOK-45    | 131  | TOYO- 8    | 231  | TRI- 8I | 133     |
| TE - 1D     | 126  | TIT-13  | 129  | TOK-45D   | 131  | TOYO- 8IP  | 231  | TRI- 9D | 133     |
| TE - 1G     | 290  | TIT-15  | 129  | TOK-46    | 131  | TOYO- 8P   | 231  | TRI- 9I | 133     |
| TE - 1I     | 126  | TIT-15D | 129  | TOK-46D   | 131  | TOYO- 9    | 231  | TRI-10D | 133     |
| TE - 2G     | 290  | TIT-16D | 129  | TOK-47    | 131  | TOYO- 9P   | 231  | TRI-10I | 133     |
| TE - 3      | 126  | TIT-17  | 129  | TOK-47D   | 131  | TOYO- 9P1  | 231  | TRI-11D | 133     |
| TE - 3G     | 290  | TIT-18D | 129  | TOK-48    | 131  | TOYO-10    | 231  | TRI-11I | 133     |
| TE - 4      | 126  | TIT-19D | 128  | TOK-48D   | 131  | TOYO-10P   | 231  | TRI-12D | 133     |
| TE - 7D     | 127  | TK-2D   | 126  | TOK-49    | 131  | TOYO-10P1  | 231  | TRI-12I | 133     |
| TE - 8D     | 127  | TK-2I   | 126  | TOK-50    | 131  | TOYO-11    | 231  | TRI-13  | 133     |
| TE - 8DKT1  | 127  | TKY-1   | 125  | TOK-51    | 131  | TOYO-11P   | 231  | TRI-14  | 133     |
| TE - 8I     | 127  | TKY-2   | 125  | TOK-52    | 131  | TOYO-11P1  | 231  | TRI-15  | 133     |
| TE - 9D     | 127  | TKY-3   | 125  | TOK-53    | 131  | TOYO-12    | 231  | TRI-16  | 133     |
| TE -10I     | 127  | TOK- 2  | 130  | TOK-54    | 131  | TOYO-12D   | 231  | TRI-17D | 133     |
| TE -11D     | 127  | TOK- 2D | 130  | TOK-55    | 131  | TOYO-12DP1 | 231  | TRI-18  | 133     |
| TE -23      | 127  | TOK- 3  | 130  | TOK-56D   | 131  | TOYO-12P1  | 231  | TRI-18D | 133     |
| TE -28      | 127  | TOK- 3D | 130  | TOK-58    | 131  | TOYO-13    | 231  | TRI-19  | 133     |
| TE -T10     | 127  | TOK- 4D | 130  | TOK-59    | 131  | TOYO-13P1  | 231  | TRI-19D | 133     |
| TE -T10D    | 127  | TOK- 5D | 130  | TOK-60    | 131  | TOYO-14    | 230  | TRI-20  | 133     |
| TE -T11     | 127  | TOK- 6  | 130  | TOK-61    | 131  | TOYO-14P   | 230  | TRL-1P  | 132-233 |
| TE -T12PLUS | 127  | TOK- 6D | 130  | TOK-62    | 131  | TOYO-15    | 232  | TRL-2   | 132     |
| TE -T60     | 127  | TOK- 7D | 130  | TOK-62D   | 131  | TOYO-15P   | 232  | TRM- 4  | 134     |
| TE -T62     | 127  | TOK- 8  | 131  | TOK-63    | 131  | TOYO-16    | 232  | TRM-11D | 134     |
| TE -T80     | 127  | TOK- 9  | 130  | TOK-64    | 131  | TOYO-16P   | 232  | TRO-1   | 126     |
| TE -T8OSC   | 127  | TOK-10D | 130  | TOK-65    | 131  | TOYO-16P1  | 232  | TRO-1D  | 126     |
| TE -T82     | 127  | TOK-11  | 130  | TOK-66    | 131  | TOYO-17    | 232  | TRP-1D  | 233     |
| TEC-1G      | 325  | TOK-12  | 130  | TOK-67    | 131  | TOYO-17P   | 232  | TRU- 7  | 134     |
| TEC-2       | 126  | TOK-13D | 130  | TOK-68    | 131  | TOYO-18P   | 232  | TRU- 8P | 135     |
| TEI-1D      | 126  | TOK-14D | 130  | TOK-69    | 131  | TOYO-19P   | 232  | TRV-1   | 132     |
| TEM-D35     | 126  | TOK-15  | 130  | TOK-70    | 131  | TOYO-20D   | 232  | TRV-1D  | 132     |
| TEM-D55     | 126  | TOK-16D | 130  | TOK-71    | 131  | TOYO-22    | 232  | TSI-1G  | 325     |
| TEM-I35     | 126  | TOK-17D | 130  | TOK-71D   | 131  | TOYO-22D   | 232  | TST-1   | 134     |
| TEM-I55     | 126  | TOK-18  | 130  | TOK-72    | 131  | TOYO-23    | 233  | TTN-1G  | 326     |
| TEU-1       | 229  | TOK-19  | 130  | TOK-73    | 131  | TOYO-23P   | 233  | TTN-2G  | 326     |
| TH-1        | 128  | TOK-20  | 130  | TOK-74    | 131  | TOYO-24    | 233  | TUF-1X  | 253     |
| TI-1        | 128  | TOK-21  | 131  | TOK-75    | 131  | TOYO-25    | 233  | TUF-2X  | 253     |
| TI-1D       | 128  | TOK-21D | 131  | TOK-76    | 131  | TOYO-26    | 233  | TUF-3X  | 253     |
| TIF- 1D     | 128  | TOK-22  | 131  | TOK-77    | 131  | TOYO-27    | 233  | TUL-1D  | 135     |
| TIF- 2D     | 128  | TOK-23  | 130  | TOK-78    | 131  | TOYO-28P   | 233  | TUL-2D  | 135     |
| TIF-15-20   | 128  | TOK-24  | 131  | TOM-1D    | 132  | TOYO-29    | 233  | TUS-1D  | 135     |
| TIF-25D     | 128  | TOK-25  | 130  | TOO-1D    | 229  | TOYO-30P1  | 233  | TUS-1G  | 326     |
| TIF-30D     | 128  | TOK-26  | 130  | TOO-2     | 230  | TOYO-37D   | 233  | TUS-2D  | 135     |
| TIF-40D     | 128  | TOK-27  | 130  | TOP-1     | 132  | TOYO-K1    | 230  | TV- 1D  | 134     |
| TIF-50-60   | 128  | TOK-28D | 130  | TOV-1     | 132  | TOYO-K1P   | 230  | TV- 1G  | 290     |
| TIG-1D      | 128  | TOK-29D | 130  | TOV-1G    | 326  | TR-1G      | 326  | TV- 2D  | 134     |
| TIT- 1D     | 128  | TOK-30  | 130  | TOV-2     | 132  | TRI- 1D    | 133  | TV- 2G  | 290     |
| TIT- 2      | 128  | TOK-31  | 130  | TOV-3     | 132  | TRI- 1I    | 133  | TV- 3D  | 134     |
| TIT- 2D     | 128  | TOK-32  | 130  | TOV-4     | 132  | TRI- 2D    | 133  | TV- 3G  | 291     |
| TIT- 2GD    | 129  | TOK-33  | 130  | TOV-5     | 132  | TRI- 2I    | 133  | TV- 4D  | 134     |
| TIT- 3      | 129  | TOK-34D | 130  | TOV-6     | 132  | TRI- 3D    | 133  | TV- 5G  | 291     |
| TIT- 4      | 129  | TOK-37  | 131  | TOV-7     | 132  | TRI- 3I    | 133  | TV- 7G  | 291     |
| TIT- 5      | 129  | TOK-38  | 131  | TOYO- 2   | 230  | TRI- 4D    | 133  | TV- 8G  | 291     |
| TIT- 6      | 129  | TOK-39  | 131  | TOYO- 3   | 230  | TRI- 4I    | 133  | TV- 9G  | 291     |
| TIT- 7D     | 229  | TOK-40  | 131  | TOYO- 3P  | 230  | TRI- 5D    | 133  | TV-10G  | 291     |
| TIT- 8D     | 129  | TOK-41  | 131  | TOYO- 4   | 230  | TRI- 5I    | 133  | TV-11   | 134     |
| TIT- 8GD    | 129  | TOK-41D | 131  | TOYO- 4P  | 230  | TRI- 6D    | 133  | TV-11G  | 291     |
| TIT- 9      | 129  | TOK-42  | 131  | TOYO- 5   | 230  | TRI- 6I    | 133  | TV-12   | 134     |
| TIT- 9D     | 129  | TOK-43  | 131  | TOYO- 5P  | 230  | TRI- 7D    | 133  | TV-12G  | 291     |
| TIT-10      | 128  | TOK-44  | 131  | TOYO- 5P1 | 230  | TRI- 7I    | 133  | TV-13   | 134     |
| TIT-11D     | 129  | TOK-44D | 131  | TOYO- 6   | 230  | TRI- 8D    | 133  | TV-13G  | 291     |

# ÍNDICE GENERAL

## GENERAL INDEX

| REF.   | PAG. |
|--------|------|
| TV-14G | 291  |
| TV-15D | 134  |
| TV-15G | 291  |
| TV-16D | 134  |
| TV-16G | 291  |
| TV-17  | 134  |
| TV-17D | 134  |
| TV-17G | 291  |
| TV-18D | 134  |
| TV-18G | 291  |
| TV-19D | 134  |
| TV-19G | 291  |
| TV-20  | 134  |
| TV-20G | 291  |
| TV-21  | 134  |
| TV-21G | 291  |
| TV-22  | 134  |
| TV-22D | 134  |
| TV-22G | 292  |
| TV-23  | 134  |
| TV-23D | 134  |
| TV-23G | 292  |
| TV-24G | 292  |
| TV-25G | 292  |
| TV-26G | 292  |
| TV-27G | 292  |
| TV-30  | 134  |
| TV-31  | 134  |
| TV-32  | 134  |
| TX-1   | 138  |
| TX-3D  | 138  |
| TZ-1   | 135  |
| TZ-1D  | 135  |

### U

|           |     |
|-----------|-----|
| U- 1D     | 138 |
| U- 1G     | 345 |
| U- 1G NIQ | 345 |
| U- 1I     | 138 |
| U- 1X     | 253 |
| U- 2D     | 138 |
| U- 2I     | 138 |
| U- 3D     | 138 |
| U- 3I     | 138 |
| U- 4AD    | 139 |
| U- 4AI    | 139 |
| U- 4D     | 138 |
| U- 4I     | 138 |
| U- 4JD    | 139 |
| U- 4JI    | 139 |
| U- 4TD    | 139 |
| U- 4TI    | 139 |
| U- 5AD    | 139 |
| U- 5AI    | 139 |
| U- 5BD    | 139 |
| U- 5BI    | 139 |
| U- 5CD    | 139 |
| U- 5CI    | 139 |
| U- 5D     | 139 |
| U- 5DD    | 139 |

| REF.    | PAG. |
|---------|------|
| U- 5DI  | 139  |
| U- 5DSP | 140  |
| U- 5ED  | 139  |
| U- 5EI  | 139  |
| U- 5FD  | 139  |
| U- 5FI  | 139  |
| U- 5I   | 139  |
| U- 5JD  | 139  |
| U- 5JI  | 139  |
| U- 5KD  | 139  |
| U- 5KI  | 139  |
| U- 5MD  | 140  |
| U- 5MI  | 140  |
| U- 5PD  | 140  |
| U- 5PI  | 140  |
| U- 5QD  | 140  |
| U- 5QI  | 140  |
| U- 5SD  | 140  |
| U- 5SI  | 140  |
| U- 5SP  | 140  |
| U- 5TD  | 140  |
| U- 5TI  | 140  |
| U- 5VD  | 140  |
| U- 5VI  | 140  |
| U- 5XD  | 140  |
| U- 5XI  | 140  |
| U- 5YD  | 140  |
| U- 5YI  | 140  |
| U- 6BD  | 140  |
| U- 6D   | 140  |
| U- 6GD  | 140  |
| U- 6I   | 140  |
| U- 7    | 141  |
| U- 7D   | 141  |
| U- 8    | 141  |
| U- 8D   | 141  |
| U- 8PD  | 141  |
| U- 8TD  | 141  |
| U- 9    | 141  |
| U- 9D   | 141  |
| U-10D   | 141  |
| U-10I   | 141  |
| U-13D   | 141  |
| U-13I   | 141  |
| U-14D   | 141  |
| U-14I   | 141  |
| U-15    | 141  |
| U-15D   | 141  |
| U-15GD  | 141  |
| U-15GI  | 141  |
| U-16    | 141  |
| U-16D   | 141  |
| U-17    | 141  |
| U-17D   | 141  |
| U-18D   | 142  |
| U-19    | 142  |
| U-19D   | 142  |
| U-21    | 142  |
| U-21D   | 142  |
| U-22    | 142  |

| REF.      | PAG.    |
|-----------|---------|
| U-22D     | 142     |
| U-25      | 142     |
| U-25D     | 142     |
| U-26      | 142     |
| U-26D     | 142     |
| U-26GD    | 142     |
| UCEM- 1D  | 135     |
| UCEM- 1G  | 292     |
| UCEM- 1I  | 135     |
| UCEM- 2D  | 135     |
| UCEM- 2G  | 292     |
| UCEM- 2I  | 135     |
| UCEM- 3   | 135     |
| UCEM- 3G  | 292     |
| UCEM- 4I  | 135     |
| UCEM- 5D  | 136     |
| UCEM- 5I  | 136     |
| UCEM- 7D  | 136     |
| UCEM- 7I  | 136     |
| UCEM- 8D  | 136     |
| UCEM- 8DP | 136     |
| UCEM-12   | 135     |
| UCEM-13D  | 136     |
| UCEM-17D  | 136     |
| UL-1      | 136     |
| UL-2D     | 136     |
| UL-3      | 136     |
| UL-4      | 136     |
| UMF-1     | 136     |
| UN- 1FS   | 137-234 |
| UN- 1G    | 292     |
| UN- 2     | 137-234 |
| UN- 3     | 137-234 |
| UN- 4     | 234     |
| UN- 5D    | 137     |
| UN- 6D    | 137     |
| UN- 7D    | 137     |
| UN- 7I    | 137     |
| UN- 8D    | 137     |
| UN- 8I    | 137     |
| UN- 9D    | 138     |
| UN- 9I    | 138     |
| UN-10D    | 138     |
| UN-10I    | 138     |
| UN-11     | 138     |
| UN-12I    | 137     |
| UN-13D    | 137     |
| UN-13I    | 137     |
| UN-14D    | 137     |
| UN-14I    | 137     |
| UN-15D    | 137     |
| UN-15I    | 137     |
| UN-16D    | 137     |
| UN-16I    | 137     |
| UN-17D    | 137     |
| UN-17I    | 137     |
| UN-18D    | 137     |
| UN-18I    | 137     |
| UN-19D    | 137     |
| UN-19I    | 137     |

| REF.   | PAG.    |
|--------|---------|
| UN-20D | 137     |
| UN-20I | 137     |
| UN-21D | 137     |
| UN-21I | 137     |
| UN-22D | 137     |
| UN-22I | 137     |
| UN-23D | 137     |
| UN-23I | 137     |
| UN-24D | 137     |
| UN-24I | 137     |
| UN-25D | 137     |
| UN-25I | 137     |
| UN-26D | 137     |
| UN-26I | 137     |
| UN-27D | 137     |
| UN-27I | 137     |
| UN-28I | 137     |
| UN-29D | 137     |
| UN-29I | 137     |
| UN-30D | 137     |
| UN-30I | 137     |
| UN-31D | 137     |
| UN-31I | 137     |
| UN-32D | 137     |
| UN-32I | 137     |
| UN-33D | 137     |
| UN-33I | 137     |
| UN-34D | 137     |
| UN-34I | 137     |
| UN-35D | 137     |
| UN-35I | 137     |
| UN-36D | 137     |
| UN-36I | 137     |
| UN-37D | 137     |
| UN-37I | 137     |
| UN-38D | 137     |
| UN-38I | 137     |
| UN-39D | 137     |
| UN-39I | 137     |
| UN-40D | 137     |
| UN-40I | 137     |
| UN-41D | 137     |
| UN-41I | 137     |
| UN-42D | 137     |
| UN-42I | 137     |
| UN-43D | 137     |
| UN-43I | 137     |
| UN-44  | 137-234 |
| UN-44D | 137-234 |
| UN-45D | 138     |
| UN-46D | 138-234 |
| UN-47  | 138     |
| UN-FFE | 137-234 |
| UN-FK  | 138-234 |
| UN-FP  | 137-234 |
| UN-FR  | 137-234 |
| UN-FS  | 138-234 |
| UN-FT  | 234     |
| UN-MRN | 137-234 |
| UN-NC  | 234     |

| REF.    | PAG.    |
|---------|---------|
| UN-NG   | 137-234 |
| UN-NH   | 234     |
| UN-NHP  | 234     |
| UN-TF   | 234     |
| URB-1   | 142     |
| URB-1D  | 142     |
| URB-2   | 142     |
| URB-3D  | 142     |
| URB-4D  | 142     |
| URKO-1D | 142     |
| URKO-1I | 142     |
| URKO-2D | 142     |
| URKO-2I | 142     |
| URKO-3D | 142     |
| URKO-3I | 142     |
| URKO-4  | 142-349 |

### V

|          |         |
|----------|---------|
| V-1G     | 345     |
| V-1G(CV) | 345     |
| V-2G     | 345     |
| V-2G(CV) | 345     |
| V-3G     | 345     |
| V-3G(CV) | 345     |
| V-4G(CV) | 345     |
| V-5G(CV) | 345     |
| VA- 1    | 143     |
| VA- 2    | 143     |
| VA- 3    | 143-235 |
| VA- 3I   | 143-235 |
| VA- 4    | 143     |
| VA- 4D   | 143     |
| VA- 5    | 143     |
| VA- 6    | 235     |
| VA- 6P   | 235     |
| VA- 7    | 235     |
| VA- 8D   | 143     |
| VA- 9D   | 144     |
| VA-10    | 144-235 |
| VA-11    | 145     |
| VA-12D   | 144     |
| VA-13D   | 143     |
| VA-13I   | 143     |
| VA-14D   | 144     |
| VA-15    | 144     |
| VA-16    | 235     |
| VA-17P   | 235     |
| VA-18    | 235     |
| VA-19    | 143     |
| VA-20    | 143     |
| VA-21    | 143     |
| VA-22    | 143     |
| VA-23    | 143     |
| VA-24D   | 144     |
| VA-24I   | 144     |
| VA-25    | 144     |
| VA-26    | 144     |
| VA-27    | 144     |
| VA-28    | 144     |
| VA-29    | 144     |

| REF.    | PAG. |
|---------|------|
| VA-29D  | 144  |
| VA-30   | 144  |
| VA-31D  | 144  |
| VA-32D  | 144  |
| VA-33D  | 144  |
| VA-34   | 235  |
| VA-34P  | 235  |
| VA-34P1 | 235  |
| VA-35   | 144  |
| VA-35D  | 144  |
| VA-36   | 145  |
| VA-37   | 145  |
| VA-38   | 145  |
| VA-39   | 145  |
| VA-40   | 145  |
| VA-41   | 145  |
| VA-42   | 145  |
| VA-43   | 145  |
| VA-44   | 145  |
| VA-45   | 145  |
| VA-46   | 145  |
| VA-47   | 145  |
| VA-48   | 145  |
| VA-49   | 145  |
| VA-50   | 145  |
| VA-51   | 145  |
| VA-52   | 145  |
| VA-53   | 145  |
| VA-54   | 145  |
| VA-55   | 145  |
| VA-56   | 144  |
| VA-57   | 145  |
| VA-58   | 145  |
| VA-59   | 145  |
| VA-60   | 145  |
| VA-61C1 | 235  |
| VA-61C2 | 236  |
| VA-62   | 144  |
| VA-62D  | 144  |
| VA-70   | 145  |
| VA-75D  | 143  |
| VA-DHP  | 143  |
| VA-LA   | 143  |
| VA-LB   | 143  |
| VA-LC   | 143  |
| VA-LD   | 143  |
| VA-LE   | 143  |
| VA-LF   | 143  |
| VA-LG   | 143  |
| VA-LH   | 143  |
| VA-LN   | 143  |
| VA-RA   | 143  |
| VA-RB   | 143  |
| VA-RC   | 143  |
| VA-RD   | 143  |
| VA-RDH  | 143  |
| VA-RDM  | 143  |
| VA-RE   | 143  |
| VA-RF   | 143  |
| VA-RG   | 143  |

| REF.     | PAG. |
|----------|------|
| VA-RH    | 143  |
| VA-RHM   | 143  |
| VA-RJ    | 143  |
| VA-RK    | 143  |
| VA-RL    | 143  |
| VA-RM    | 143  |
| VA-RN    | 143  |
| VA-ROK   | 143  |
| VB-1D    | 146  |
| VB-2D    | 146  |
| VE-1D    | 146  |
| VG-1D    | 148  |
| VGf-4D   | 147  |
| VGf-4I   | 147  |
| VGf-5D   | 147  |
| VGf-5I   | 147  |
| VI- 1D   | 147  |
| VI- 1I   | 147  |
| VI- 2D   | 147  |
| VI- 2I   | 147  |
| VI- 4D   | 147  |
| VI- 4DP  | 147  |
| VI- 4I   | 147  |
| VI- 4IP  | 147  |
| VI- 5D   | 147  |
| VI- 6D   | 147  |
| VI- 7    | 147  |
| VI- 8    | 147  |
| VI- 8D   | 147  |
| VI- 9D   | 147  |
| VI-10    | 148  |
| VI-11    | 148  |
| VI-11D   | 148  |
| VI-12    | 147  |
| VI-14    | 148  |
| VI-15    | 147  |
| VI-16D   | 148  |
| VILL-1G  | 333  |
| VIN-1D   | 147  |
| VLK-1    | 148  |
| VLK-2    | 148  |
| VND-1    | 146  |
| VND-1D   | 146  |
| VND-2    | 146  |
| VND-2D   | 146  |
| VND-3    | 147  |
| VO -1    | 194  |
| VO -2    | 194  |
| VO -2DP  | 194  |
| VO -2DP1 | 194  |
| VO -2P   | 194  |
| VO -2P1  | 194  |
| VO -5P   | 194  |
| VO -6D   | 194  |
| VO -7    | 174  |
| VO -8P   | 194  |
| VO -8P1  | 194  |
| VO -AH   | 195  |
| VO -AHP  | 195  |
| VO -FH   | 195  |

| REF.     | PAG. |
|----------|------|
| VO -FHP  | 195  |
| VO -FHP1 | 195  |
| VO -HV   | 195  |
| VO -HVP  | 195  |
| VO -K    | 195  |
| VO -L    | 195  |
| VO -M    | 195  |
| VO -MP   | 195  |
| VO -N    | 195  |
| VO -NP   | 195  |
| VO -R    | 195  |
| VO -RP   | 195  |
| VO -VA   | 195  |
| VO -VAP  | 195  |
| VO -VB   | 195  |
| VO -VBP  | 195  |
| VO -VBP1 | 196  |
| VOL-1    | 236  |
| VOL-1P   | 236  |
| VOL-2    | 236  |
| VOL-2D   | 236  |
| VOL-3    | 236  |
| VOL-4    | 236  |
| VOL-5P   | 236  |
| VW-K70   | 196  |

## W

|           |     |
|-----------|-----|
| WA-1D     | 148 |
| WA-4D     | 148 |
| WA-4I     | 148 |
| WA-5D     | 148 |
| WA-5DP    | 148 |
| WA-5I     | 148 |
| WA-5IP    | 148 |
| WAL-1D    | 148 |
| WAL-2D    | 149 |
| WAN-1D    | 149 |
| WAS - 1   | 236 |
| WAS - 2P  | 236 |
| WAS - 3   | 237 |
| WAS - 3P  | 237 |
| WAS - 4   | 237 |
| WAS - 4P  | 237 |
| WAS - 5   | 237 |
| WAS - 5P  | 237 |
| WAS - 6   | 237 |
| WAS - 6P  | 237 |
| WAS - 7D  | 237 |
| WAS - 7I  | 237 |
| WAS - 8   | 237 |
| WAS - 8D  | 237 |
| WAS - 9   | 237 |
| WAS - 9D  | 237 |
| WAS -10DP | 237 |
| WAS -10P  | 237 |
| WBS-1     | 149 |
| WE-1G     | 326 |
| WE-2G     | 326 |
| WE-4D     | 149 |
| WE-4I     | 149 |

| REF.    | PAG. |
|---------|------|
| WE-5D   | 149  |
| WE-5I   | 149  |
| WE-6D   | 149  |
| WEB-1   | 149  |
| WEB-2   | 149  |
| WEB-3   | 149  |
| WEI-1   | 149  |
| WEI-2   | 149  |
| WEI-3   | 149  |
| WEI-4   | 149  |
| WEI-5   | 149  |
| WEI-6   | 149  |
| WES-1D  | 149  |
| WHI-1D  | 150  |
| WIL- 1D | 150  |
| WIL- 2D | 150  |
| WIL- 3D | 150  |
| WIL- 4D | 150  |
| WIL- 5  | 150  |
| WIL- 5D | 150  |
| WIL- 7  | 150  |
| WIL- 8  | 150  |
| WIL- 9  | 150  |
| WIL-10  | 151  |
| WIL-11  | 151  |
| WIL-12  | 151  |
| WIL-13  | 151  |
| WIL-14  | 151  |
| WIL-15  | 151  |
| WIL-16  | 151  |
| WIL-17D | 151  |
| WIL-18  | 150  |
| WIL-19D | 150  |
| WIL-20  | 151  |
| WIL-22  | 151  |
| WIL-24  | 150  |
| WIL-25  | 150  |
| WIL-26  | 150  |
| WIL-27  | 150  |
| WIL-28  | 150  |
| WIL-29  | 150  |
| WIL-30  | 150  |
| WIL-31D | 150  |
| WIL-32  | 150  |
| WIL-33D | 150  |
| WIL-34D | 150  |
| WIL-35D | 150  |
| WIL-36D | 150  |
| WIL-37D | 150  |
| WIL-38D | 150  |
| WIL-39D | 150  |
| WIL-40D | 150  |
| WIL-41D | 150  |
| WIL-43D | 150  |
| WIL-44  | 150  |
| WIL-45D | 150  |
| WIL-46D | 150  |
| WIL-47D | 150  |
| WIL-48D | 150  |
| WIL-49D | 150  |

| REF.    | PAG.    |
|---------|---------|
| WIL-50D | 150     |
| WIL-51D | 150     |
| WIL-52  | 150     |
| WIL-53  | 150     |
| WIL-54  | 150     |
| WIL-55  | 150     |
| WIL-56  | 150     |
| WIL-57D | 150     |
| WIL-58D | 150     |
| WIL-59D | 150     |
| WIL-60D | 150     |
| WIL-61  | 150     |
| WIL-62  | 150     |
| WIL-63D | 150     |
| WIL-65D | 150     |
| WIN- 1D | 151     |
| WIN- 1I | 151     |
| WIN- 2D | 151     |
| WIN- 3D | 151     |
| WIN- 4D | 151     |
| WIN- 5  | 151     |
| WIN- 5D | 151     |
| WIN- 6D | 151     |
| WIN-21  | 151     |
| WIN-22  | 151     |
| WIR-1   | 151     |
| WIT-1   | 237     |
| WM-1D   | 152     |
| WM-1G   | 292     |
| WM-2D   | 152     |
| WM-3D   | 152     |
| WM-4D   | 152     |
| WM-5D   | 152     |
| WNC-1   | 151     |
| WST-1D  | 150-237 |
| WST-2D  | 150-237 |
| WT-1    | 152     |

## Y

|        |     |
|--------|-----|
| YA- 1D | 152 |
| YA- 1G | 327 |
| YA- 1I | 152 |
| YA- 1X | 253 |
| YA- 2D | 152 |
| YA- 2G | 327 |
| YA- 2I | 152 |
| YA- 2X | 254 |
| YA- 3D | 152 |
| YA- 3G | 327 |
| YA- 3I | 152 |
| YA- 3X | 254 |
| YA- 4G | 327 |
| YA- 4X | 254 |
| YA- 5D | 152 |
| YA- 5G | 292 |
| YA- 5I | 152 |
| YA- 5X | 254 |
| YA- 6D | 152 |
| YA- 6I | 152 |
| YA- 6X | 254 |



# ÍNDICE GENERAL

## GENERAL INDEX

| REF.    | PAG.    | REF.     | PAG. | REF.      | PAG. | REF.     | PAG.    | REF.    | PAG. |
|---------|---------|----------|------|-----------|------|----------|---------|---------|------|
| YA- 7D  | 152     | YA- 58   | 154  | YAMA- 7I  | 238  | YET- 3D  | 156     | ZE- 7D  | 75   |
| YA- 7I  | 152     | YA- 58D  | 154  | YAMA- 8D  | 238  | YET- 4   | 156     | ZE- 7X  | 255  |
| YA- 8D  | 152     | YA- 59   | 154  | YAMA- 8I  | 238  | YET- 4D  | 156     | ZE- 8   | 75   |
| YA- 8I  | 152     | YA- 59D  | 154  | YAMA- 9D  | 238  | YET- 5   | 157     | ZE- 8X  | 255  |
| YA- 9I  | 152     | YA- 72   | 155  | YAMA- 9I  | 238  | YET- 5D  | 157     | ZE- 9D  | 74   |
| YA- 10  | 153     | YA- 79D  | 155  | YAMA-10D  | 239  | YET- 6   | 157     | ZE- 9X  | 255  |
| YA- 10D | 153     | YA- 81   | 155  | YAMA-10I  | 239  | YET- 6D  | 157     | ZE- 10D | 76   |
| YA- 11D | 153     | YA- 85D  | 155  | YAMA-11D  | 239  | YET- 7   | 157     | ZE- 11D | 76   |
| YA- 11I | 153     | YA- 88   | 155  | YAMA-11I  | 239  | YET- 7D  | 157     | ZE- 13  | 76   |
| YA- 12D | 153     | YA- 89   | 155  | YAMA-12D  | 239  | YET- 8   | 157     | ZE- 14D | 74   |
| YA- 12I | 153     | YA- 91   | 154  | YAMA-12I  | 239  | YET- 8D  | 157     | ZE- 15  | 75   |
| YA- 13D | 153     | YA- 91D  | 154  | YAMA-13D  | 239  | YET- 9   | 157     | ZE- 16D | 75   |
| YA- 13I | 153     | YA- 92   | 154  | YAMA-13I  | 239  | YET- 9D  | 157     | ZE- 17D | 75   |
| YA- 14D | 153     | YA- 92D  | 154  | YAMA-14D  | 239  | YET- 10  | 157     | ZE- 18D | 75   |
| YA- 14I | 153     | YA- 93   | 154  | YAMA-14I  | 239  | YET- 10D | 157     | ZE- 19  | 75   |
| YA- 15D | 153     | YA- 94   | 154  | YAMA-15D  | 239  | YET- 11  | 157     | ZE- 20  | 75   |
| YA- 15I | 153     | YA- 95   | 154  | YAMA-15I  | 239  | YET- 11D | 157     | ZE- 21D | 75   |
| YA- 16D | 152     | YA- 97D  | 155  | YAMA-16D  | 239  | YET- 12  | 157     | ZE- 22  | 75   |
| YA- 17D | 153     | YA- 98D  | 155  | YAMA-16I  | 239  | YET- 13  | 157     | ZE- 23D | 76   |
| YA- 17I | 153     | YA- 99D  | 155  | YAMA-17D  | 239  | YET- 14  | 156     | ZE- 24D | 76   |
| YA- 18D | 237     | YA- 100D | 155  | YAMA-17I  | 239  | YET- 14D | 156     | ZE- 25D | 76   |
| YA- 19D | 238     | YA- 101D | 155  | YAMA-18D  | 239  | YET- 15  | 156     | ZE- 26D | 76   |
| YA- 20D | 238     | YA- 102D | 155  | YAMA-18DP | 239  | YET- 16  | 156     | ZE- 27D | 76   |
| YA- 20I | 238     | YA- 103D | 155  | YAMA-18I  | 239  | YET- 17D | 157     | ZE- 28D | 76   |
| YA- 21D | 238     | YA- 108  | 155  | YAMA-18IP | 239  | YU- 1D   | 240     | ZE- 29D | 76   |
| YA- 21I | 238     | YA- 111  | 155  | YAMA-19D  | 239  | YUH- 1D  | 157     | ZE- 30D | 76   |
| YA- 22D | 153     | YA- 112  | 155  | YAMA-19DP | 239  | YUH- 2D  | 157     | ZE- 31D | 76   |
| YA- 22I | 153     | YA- 113  | 155  | YAMA-19I  | 239  | YW- 1P   | 157-240 | ZE- 32D | 76   |
| YA- 23  | 153     | YA- 142D | 155  | YAMA-19IP | 239  |          |         | ZE- 33D | 76   |
| YA- 24D | 153     | YA- 186D | 155  | YAMA-20D  | 239  | <b>Z</b> |         | ZE- 34D | 76   |
| YA- 24I | 153     | YA- 206D | 155  | YAMA-20DP | 239  | ZA- 1    | 157-240 | ZE- 35  | 77   |
| YA- 25D | 153     | YA- 208D | 155  | YAMA-20I  | 239  | ZA- 1P   | 158-240 | ZE- 35D | 77   |
| YA- 25I | 153     | YA- 209D | 155  | YAMA-20IP | 239  | ZA- 2P   | 240     | ZE- 36D | 75   |
| YA- 26I | 153     | YA- 210D | 155  | YAMA-21I  | 239  | ZA- 3D   | 240     | ZE- 37D | 75   |
| YA- 27  | 153     | YA- 212D | 155  | YAMA-21IP | 239  | ZA- 4DP  | 240     | ZE- 38  | 75   |
| YA- 27D | 153     | YA- 216  | 156  | YAMA-22DP | 239  | ZA- 5DP  | 241     | ZE- 39  | 75   |
| YA- 28  | 154     | YA- 217  | 156  | YAMA-22IP | 239  | ZA- 5P   | 241     | ZE- 40D | 75   |
| YA- 28D | 154     | YA- 219  | 156  | YAMA-23DP | 239  | ZA- 6DP  | 241     | ZE- 41  | 75   |
| YA- 29  | 153     | YA- 220  | 156  | YAMA-23IP | 239  | ZA- 6DP1 | 241     | ZE- 42  | 75   |
| YA- 30  | 154-349 | YA- 221  | 156  | YAMA-24DP | 239  | ZA- 7DP  | 241     | ZE- 43  | 75   |
| YA- 31D | 154     | YA- 225  | 156  | YAMA-24IP | 239  | ZA- 8P   | 241     | ZE- 44D | 75   |
| YA- 32D | 152     | YA- 226  | 156  | YAMA-25DP | 240  | ZA- 9P   | 241     | ZE- 45D | 75   |
| YA- 33D | 154     | YA- 227  | 156  | YAMA-26   | 240  | ZA- 9P1  | 241     | ZE- 46  | 75   |
| YA- 34D | 154     | YA- 228  | 156  | YAMA-26D  | 240  | ZA- 10   | 241     | ZE- 47D | 76   |
| YA- 36D | 154     | YA- 229  | 156  | YAMA-26DP | 240  | ZA- 12   | 158-241 | ZE- 48D | 76   |
| YA- 37  | 154-238 | YA- 232  | 156  | YAMA-26P  | 240  | ZA- 13P  | 241     | ZE- 49D | 76   |
| YA- 37D | 154-238 | YA- 272D | 155  | YAMA-27   | 240  | ZE- 1    | 74      | ZE- 50D | 76   |
| YA- 38D | 154     | YA- 273D | 156  | YAMA-27D  | 240  | ZE- 1D   | 74      | ZE- 51D | 76   |
| YA- 39  | 153     | YAMA- 1D | 238  | YAMA-27DP | 240  | ZE- 1X   | 254     | ZE- 52D | 76   |
| YA- 39D | 153     | YAMA- 1I | 238  | YAMA-27P  | 240  | ZE- 2    | 74      | ZE- 53D | 76   |
| YA- 46D | 154     | YAMA- 2D | 238  | YAMA-28P  | 240  | ZE- 2D   | 74      | ZE- 54D | 76   |
| YA- 50  | 154     | YAMA- 2I | 238  | YAMA-29P  | 240  | ZE- 2X   | 254     | ZE- 55D | 76   |
| YA- 50D | 154     | YAMA- 3D | 238  | YAMA-30P  | 240  | ZE- 3X   | 254     | ZE- 56D | 76   |
| YA- 51  | 154     | YAMA- 3I | 238  | YAR- 1    | 156  | ZE- 4X   | 254     | ZE- 57D | 76   |
| YA- 51D | 154     | YAMA- 4D | 238  | YAR- 2    | 156  | ZE- 5D   | 75      | ZE- 58D | 76   |
| YA- 52D | 154     | YAMA- 5D | 238  | YAR- 3    | 156  | ZE- 5I   | 75      | ZE- 59D | 76   |
| YA- 53  | 154     | YAMA- 5I | 238  | YET- 1    | 156  | ZE- 5X   | 254     | ZE- 60D | 76   |
| YA- 53D | 154     | YAMA- 6D | 238  | YET- 1D   | 156  | ZE- 6    | 74      | ZE- 61D | 76   |
| YA- 57  | 154     | YAMA- 6I | 238  | YET- 2    | 156  | ZE- 6D   | 74      | ZE- 62D | 76   |
| YA- 57D | 154     | YAMA- 7D | 238  | YET- 2D   | 156  | ZE- 6X   | 254     | ZE- 63D | 76   |

| REF.   | PAG. |
|--------|------|
| ZE-64D | 76   |
| ZE-65D | 76   |
| ZE-66D | 76   |
| ZE-67D | 76   |
| ZE-68D | 76   |
| ZE-69D | 76   |
| ZE-70D | 76   |
| ZE-71D | 75   |
| ZE-72  | 75   |
| ZE-73  | 75   |
| ZE-74  | 75   |
| ZE-75  | 75   |
| ZE-76D | 75   |
| ZE-77D | 75   |
| ZE-78D | 75   |
| ZE-79  | 75   |
| ZE-80  | 75   |
| ZE-81  | 75   |
| ZE-82  | 75   |
| ZE-83  | 75   |
| ZE-84  | 75   |

| REF.    | PAG. |
|---------|------|
| ZE-85   | 75   |
| ZE-86D  | 75   |
| ZE-87   | 75   |
| ZE-88   | 75   |
| ZE-89   | 75   |
| ZE-90   | 75   |
| ZE-91D  | 75   |
| ZE-92D  | 75   |
| ZE-93D  | 75   |
| ZE-94D  | 75   |
| ZE-95D  | 75   |
| ZE-96D  | 75   |
| ZE-97D  | 75   |
| ZE-98   | 75   |
| ZE-99   | 75   |
| ZE-100  | 75   |
| ZE-101  | 75   |
| ZE-102  | 75   |
| ZE-103  | 75   |
| ZE-104D | 75   |
| ZE-105D | 76   |

| REF.    | PAG. |
|---------|------|
| ZE-106D | 76   |
| ZE-107D | 76   |
| ZE-108D | 76   |
| ZE-109D | 76   |
| ZE-110D | 76   |
| ZE-111D | 76   |
| ZE-112D | 76   |
| ZE-113D | 76   |
| ZE-114D | 76   |
| ZE-115D | 76   |
| ZE-116D | 76   |
| ZE-117D | 76   |
| ZE-118  | 75   |
| ZE-119D | 75   |
| ZE-120  | 75   |
| ZE-121D | 75   |
| ZE-122D | 75   |
| ZE-123D | 75   |
| ZE-124  | 75   |
| ZE-125D | 76   |
| ZE-126D | 76   |

| REF.    | PAG. |
|---------|------|
| ZE-127D | 76   |
| ZE-128  | 75   |
| ZE-129D | 75   |
| ZE-130  | 75   |
| ZE-131  | 75   |
| ZE-132D | 75   |
| ZE-133D | 75   |
| ZE-134  | 75   |
| ZE-135D | 75   |
| ZE-136D | 76   |
| ZE-137  | 75   |
| ZE-138  | 75   |
| ZE-139D | 75   |
| ZE-140  | 75   |
| ZE-141D | 76   |
| ZE-142  | 75   |
| ZE-143  | 75   |
| ZE-144D | 75   |
| ZE-145D | 76   |
| ZE-146D | 76   |
| ZE-147D | 76   |

| REF.    | PAG. |
|---------|------|
| ZE-148D | 76   |
| ZE-149  | 75   |
| ZE-150  | 75   |
| ZE-151D | 75   |
| ZE-152D | 75   |
| ZE-153D | 75   |
| ZE-154D | 75   |
| ZE-155D | 75   |
| ZE-156  | 75   |
| ZE-157  | 75   |
| ZE-158  | 75   |
| ZE-159D | 77   |
| ZE-K1   | 77   |
| ZE-K2   | 77   |
| ZE-K5   | 77   |
| ZE-K6   | 77   |
| ZE-N1   | 77   |
| ZEN-1D  | 158  |
| ZI-1    | 241  |

# ÍNDICE DE MARCAS

MARKEN AURKIBIDEA

BRAND INDEX

INDEX MARQUE

HAUPTMARKE



**THE KEY TO EXCELLENCE**  
GLOBALLY UNLOCKING MILLIONS OF DOORS DAILY

## ÍNDICE DE MARCAS

MARKEN AURKIBIDEA • BRAND INDEX • INDEX MARQUE • HAUPTMARKE

| MARCA- MARKA- MAIN<br>MARQUE - MARKE | PÁG. - ORRIA - PAGE - PAGE - SEITE                                       |
|--------------------------------------|--|
| 45                                   | 1  |
| 126                                  | 283  |
| 303                                  | 1  |
| 333                                  | 1  |
| 3M                                   | 1  |
| 4TR                                  | 326  |
| <b>A</b>                             |  |
| A.M. BARAS                           | 1  |
| ABA                                  | 1  |
| ABBES                                | 88,202   |
| ABC                                  | 1,2  |
| ABLOY                                | 2  |
| ABSA                                 | 2,3,31,113,160,222   |
| ABT                                  | 147  |
| ABUS                                 | 3,4,5,6,7,14,26,37,38,39,62,65,74,81,105,112,132,147,153,157,160,240,330 |
| ACE                                  | 36   |
| ADAMSRITE                            | 7  |
| ADEMCO                               | 36,154,238   |
| AEP                                  | 7  |
| AGA                                  | 7,8,9,18,30,36,283,330,334,339,340                                       |
| AGB                                  | 9,289  |
| AGC                                  | 9,246  |
| AGE                                  | 9,1  |
| AGUEDA                               | 127  |
| AGUIA                                | 10   |
| AGUT                                 | 10   |
| AHRAM                                | 10   |
| AIZPUTE                              | 10   |
| AKARSAN                              | 293  |
| AKIRA                                | 156,157  |
| AKS                                  | 161,185,186,188,189,194,195  |
| AL                                   | 11   |
| ALA                                  | 39,246   |
| ALDRIDGE                             | 10   |
| ALE                                  | 10   |
| ALEDAL                               | 330  |
| ALFA                                 | 8,11,66  |
| ALIANCA                              | 11   |
| ALLGOOD                              | 32   |
| ALPHA                                | 11,36,161  |
| ALSO                                 | 82   |
| ALTAY                                | 11   |
| ALUNORM                              | 41   |
| AM                                   | 101  |
| AMARU                                | 11   |
| AMERICAN LOCK                        | 12   |
| AMERICAN MOTORS                      | 20,82,161,162  |
| AMIG                                 | 12,13  |
| ANA                                  | 252  |
| ANCHOR                               | 3,4,5,6,12,13  |

| MARCA- MARKA- MAIN<br>MARQUE - MARKE | PÁG. - ORRIA - PAGE - PAGE - SEITE   |
|--------------------------------------|--------------------------------------|
| ANKE                                 | 29                                   |
| ANKER                                | 13                                   |
| ANKERSLOT                            | 12,91                                |
| ANLO                                 | 69                                   |
| ANTAR                                | 13,113,114                           |
| ANTONIOLI                            | 293                                  |
| APEX                                 | 13,14                                |
| APRI                                 | 100                                  |
| ARCU                                 | 14,48,330,331,332                    |
| AREL                                 | 14                                   |
| ARES                                 | 334,335                              |
| ARFE                                 | 3,14,44,111,160,334                  |
| ARMAN                                | 174,179,180,236                      |
| ARMOR                                | 113,222                              |
| ARMSTRONG                            | 5,14                                 |
| ARNOU                                | 32                                   |
| AROUCA                               | 14                                   |
| ARREGUI                              | 3,8,14,31,55,62,160                  |
| ARROW                                | 14                                   |
| ARSENEVSK                            | 15                                   |
| ARTEB                                | 226                                  |
| ASEC                                 | 10                                   |
| ASHICO                               | 15                                   |
| ASIA                                 | 15,156,157                           |
| ASPA                                 | 15                                   |
| ASSA                                 | 15,16,17,115,126,161,283,284,293,332 |
| ASSA ABLOY                           | 155                                  |
| ASTRAL                               | 38                                   |
| ATAL                                 | 88,89,143,202                        |
| ATL                                  | 28                                   |
| ATLANTIC                             | 64                                   |
| ATLAS                                | 125                                  |
| ATP                                  | 31                                   |
| ATRA                                 | 46,79,293,294                        |
| AUMON                                | 17,44                                |
| AUNO                                 | 293                                  |
| AUTOBLOCK                            | 226                                  |
| AVA-CHUBB                            | 36                                   |
| AVANGARD                             | 17                                   |
| AXA                                  | 161,162                              |
| AXIS                                 | 38                                   |
| AYPE                                 | 332                                  |
| AZBE                                 | 17,18,151                            |
| AZKOYEN                              | 18                                   |
| AZU                                  | 162                                  |
| <b>B</b>                             |                                      |
| B+D                                  | 18                                   |
| BAB                                  | 19,43,54,113                         |
| BAGEM                                | 1,2,19                               |
| BALING LOCK                          | 125                                  |
| BALTIKA                              | 20                                   |
| BANE SEKULIC                         | 26,27,142                            |
| BANHAM                               | 20                                   |

# ÍNDICE DE MARCAS

## BRAND INDEX

| MARCA- MARKA- MAIN<br>MARQUE - MARKE | PÁG. - ORRIA - PAGE - PAGE - SEITE                 |
|--------------------------------------|--|
| BAODEAN                              | 20   |
| BARCZ                                | 20   |
| BARIER                               | 20   |
| BARRO                                | 47   |
| BASCO                                | 20,162,200   |
| BASI                                 | 20   |
| BASTA                                | 20,21,95,214,240                                   |
| BATU                                 | 21,38,74   |
| BAU                                  | 143  |
| BELL                                 | 156,157  |
| BENCO                                | 127  |
| BENDIX                               | 153,154,238  |
| BERAM                                | 147  |
| BERRY                                | 22,23,33   |
| BERTOLOTTI                           | 128  |
| BEST                                 | 21   |
| BETA                                 | 21,294,295   |
| BEY                                  | 21   |
| BIBERING                             | 21,22,130  |
| BIELLE                               | 22   |
| BIFFAR                               | 22   |
| BILMA                                | 22   |
| BIRD                                 | 63,152   |
| BKS                                  | 22,23,24,63,91,152,153,155,156,253,254             |
| BLACK & DECKER                       | 43   |
| BLAU                                 | 162,182  |
| BLOCK                                | 227  |
| BLOCTOUT                             | 26   |
| BLOCUS                               | 110,111,113  |
| BLOSTER                              | 224  |
| BLUMA                                | 246  |
| BMB                                  | 24   |
| BMC                                  | 295  |
| BMH                                  | 340  |
| BODA                                 | 24,33,34,284,295,323                               |
| BOGATIR                              | 295  |
| BOINAITI                             | 289  |
| BOMBARDIER                           | 163  |
| BOMORO                               | 25,146,163,217                                     |
| BONAITI                              | 262  |
| BÖRKEY                               | 25   |
| BOSCH                                | 163,189,217  |
| BOULTON & PAUL                       | 25   |
| BOXAFE                               | 295  |
| BRABANTIA                            | 25,40,54,99,163,166                                |
| BRAS                                 | 25   |
| BRASIL                               | 25   |
| BRETER                               | 157,158,240,241                                    |
| BRICARD                              | 4,25,26,38,86,92,116,246,284                       |
| BRIGGS & STRATTON                    | 20,162,163,164,166,175,176,177,178                 |
| BRITAX                               | 174,204  |
| BRUMME                               | 26,74,75   |
| BSS                                  | 26,27  |
| BTV                                  | 20,27,46,47,123,124,315                            |
| BUFFO                                | 4,5,6,160  |
| BUGA                                 | 27   |
| BULAT                                | 27,28  |
| BULIT                                | 3,82   |
| BURG                                 | 4,5,28,29,30,43,77,106,114,147,164,223,246,247,335 |

| MARCA- MARKA- MAIN<br>MARQUE - MARKE | PÁG. - ORRIA - PAGE - PAGE - SEITE      |
|--------------------------------------|---|
| BURG WACHTER                         | 28,29,313                               |
| BURGHOWT                             | 127                                     |
| BUS                                  | 30                                      |
| BUVA                                 | 28,3                                    |
| BWS                                  | 41                                      |
| BY                                   | 31                                      |
| BYP                                  | 13,78                                   |
| <b>C</b>                             |   |
| C.A.R.S.                             | 107                                     |
| C.V.C.                               | 13                                      |
| CAB                                  | 30,31,153                               |
| CAF                                  | 296                                     |
| CAM                                  | 323                                     |
| CAM LOCK                             | 30                                      |
| CAMA                                 | 164                                     |
| CAMBOA                               | 41                                      |
| CAP                                  | 31,11,111                               |
| CARAT                                | 63,152                                  |
| CARTERO                              | 30,31                                   |
| CAS                                  | 57                                      |
| CAS CISMA                            | 31,101,340                              |
| CASAS                                | 8                                       |
| CASELLAS                             | 164                                     |
| CASH BOX                             | 31,99                                   |
| CASI                                 | 117,174,175,185,186,188,191,192,194,195 |
| CASMA                                | 33,35                                   |
| CATERPILLAR                          | 164                                     |
| CATOR                                | 114                                     |
| CAVERS                               | 18,31,32,121                            |
| CAYS                                 | 32,44,124                               |
| CAZORLA                              | 44                                      |
| CC                                   | 127                                     |
| CCF                                  | 247,248                                 |
| CCL                                  | 42                                      |
| CEKA                                 | 72                                      |
| CEM                                  | 92,93,164,165,174,175,203,204,234       |
| CEMA                                 | 32                                      |
| CENTURION                            | 18                                      |
| CENTURY                              | 32                                      |
| CERRAMARC                            | 32                                      |
| CERUTTI                              | 296,297,332                             |
| CES                                  | 33,34,35                                |
| CESSNA                               | 165                                     |
| CF                                   | 63,319                                  |
| CFP                                  | 150                                     |
| CHANGE-O-MATIC                       | 42                                      |
| CHAVO                                | 6,36,38,39                              |
| CHELIABINSK                          | 36                                      |
| CHEYLOCK                             | 36                                      |
| CHG                                  | 65                                      |
| CHICAGO                              | 20,36,153,154,162,238                   |
| CHRIST                               | 47                                      |
| CHRYSLER                             | 165,166                                 |
| CHUBB                                | 36,284,297                              |
| CIB                                  | 63,107,110,111,135                      |
| CIBC                                 | 63                                      |
| CIBOX                                | 28                                      |
| CIEF                                 | 36                                      |
| CIELS                                | 36                                      |

| MARCA- MARKA- MAIN<br>MARQUE - MARKE | PÁG. - ORRIA - PAGE - PAGE - SEITE  |
|--------------------------------------|---|
| CIFIAL                               | 37,248  |
| CILA GENTILI                         | 37  |
| CINA                                 | 15,37,52,119  |
| CISA                                 | 3,4,5,6,37,38,39,92,141,298,299   |
| CITY                                 | 31,32,63  |
| CLARK FORK LIFT                      | 40  |
| CLASS                                | 299   |
| CLASSIC                              | 40  |
| CLAUSOR                              | 40,99,165,166,167,174,175,179,189,209,210,211,212,213,<br>214,216,217,226,228 |
| CLEMSA                               | 40  |
| CLICK                                | 167   |
| CLUM                                 | 167   |
| COBRA                                | 167,168   |
| CODEM                                | 63  |
| CODKEY                               | 121   |
| COFER                                | 98  |
| COHNKO                               | 40  |
| COLE HERSEE                          | 153   |
| COLOMENCA                            | 8   |
| COM                                  | 40  |
| COMBA                                | 33,85,130   |
| CORBIN                               | 41,42,43,48,49,50,162   |
| CORNI                                | 127,289,300   |
| CORONA                               | 43,44,77  |
| CORSA                                | 126   |
| COTICO                               | 44  |
| COUILLET                             | 112   |
| CR                                   | 254,300, 301  |
| CRAIN                                | 90  |
| CRAZY LOCKS                          | 44  |
| CRC                                  | 41  |
| CRC CAMBOA                           | 248   |
| CROMODORA                            | 224   |
| CRONOS                               | 335   |
| CUBELLS                              | 44  |
| CVL                                  | 44  |
| CWS                                  | 47  |
| <b>D</b>                             |   |
| DACIA                                | 168   |
| DAD                                  | 44,46,47,62,124,144   |
| DAELIM                               | 168   |
| DAEWO                                | 168,169   |
| DAF                                  | 45  |
| DAIHATSU                             | 169   |
| DAMM                                 | 22,23   |
| DAR-MAR                              | 285   |
| DARMIX                               | 169   |
| DATSUN                               | 213,218,219,220   |
| DAV                                  | 169   |
| DC                                   | 113   |
| DEBEAURAIN                           | 70,113,136,248,285  |
| DECAYEUX                             | 44,107,112  |
| DEFA                                 | 45  |
| DEHA                                 | 156,157   |
| DEKABA                               | 45,302  |
| DELAPORTE                            | 45,46   |
| DELCA                                | 46  |

| MARCA- MARKA- MAIN<br>MARQUE - MARKE | PÁG. - ORRIA - PAGE - PAGE - SEITE                           |
|--------------------------------------|--|
| DELTA                                | 113  |
| DERLOCHE                             | 113  |
| DESAL                                | 29   |
| DESPREZ                              | 113  |
| DEXTER                               | 46,163   |
| DIAMOND                              | 46   |
| DIEBOLD                              | 46,349   |
| DIERRE                               | 46,98  |
| DIFA                                 | 114  |
| DIMITROVGRAD                         | 46   |
| DIRAK                                | 45   |
| DJC                                  | 127  |
| DKW                                  | 162  |
| DNS                                  | 71   |
| DOBLE G                              | 169  |
| DOBLE SAFE                           | 93,94,203  |
| DOBLINA                              | 169  |
| DOCO                                 | 43   |
| DOM                                  | 41,46,47,48,49,50,51,102,103,124,169,170,174,194,227,<br>236 |
| DOMINION LOCK                        | 14,51  |
| DOMUS                                | 31,51,52,311   |
| DONNER                               | 127  |
| DOOR LOCK                            | 248  |
| DOUBLE CIRCLE                        | 52   |
| DRAPER                               | 155  |
| DUBOIS                               | 88,89,170,202  |
| DUPLEX                               | 335  |
| DURABLE                              | 28   |
| DURALOCK                             | 52   |
| DVERNIAK                             | 302,303,335,336  |
| <b>E</b>                             |  |
| EAG                                  | 52   |
| EAGLE                                | 52,71  |
| EAO                                  | 49   |
| ECHO                                 | 170  |
| ECM                                  | 52   |
| EFER                                 | 37   |
| EIKO                                 | 52   |
| ELBOR                                | 303  |
| ELCA                                 | 55,56,127  |
| ELEPHANT                             | 133  |
| ELFIN                                | 32   |
| ELMO                                 | 20,162   |
| ELSET                                | 99   |
| ELZETT                               | 33,53,285, 286,304   |
| EMGE                                 | 113  |
| EMHART                               | 48,49, 50, 113, 222  |
| EMKA                                 | 45,53, 54  |
| EMOH                                 | 162  |
| ENA OQ                               | 135  |
| EP PINSON                            | 53   |
| EPO                                  | 117  |
| EQUIBATIR                            | 113  |
| ERA                                  | 53,54, 286   |
| EREVAN                               | 304,336  |
| ERINRUDE                             | 222  |
| ERMEX                                | 126  |

# ÍNDICE DE MARCAS

## BRAND INDEX

| MARCA- MARKA- MAIN<br>MARQUE - MARKE | PÁG. - ORRIA - PAGE - PAGE - SEITE       |
|--------------------------------------|--|
| ESA                                  | 54,286                                   |
| ESAFE                                | 36,46, 47, 98, 124, 127, 136, 139        |
| ESCO                                 | 6,38, 39, 41, 42, 127                    |
| ESETY                                | 304,305                                  |
| ESLA                                 | 54                                       |
| ESS                                  | 54                                       |
| ESSENDIA                             | 6,38, 39                                 |
| ESZ                                  | 80                                       |
| ETAS                                 | 54                                       |
| ETNA                                 | 31,109                                   |
| EUREKA                               | 54                                       |
| EURO                                 | 44                                       |
| EURO BOX                             | 54                                       |
| EURO LOCKS                           | 21,36, 54, 55, 92, 93, 94, 170, 203, 204 |
| EURO PRO                             | 148                                      |
| EURO SPEC                            | 138                                      |
| EURONORM                             | 41,42                                    |
| EUROP                                | 125                                      |
| EUROPARTNER                          | 41                                       |
| EUROPROFIL                           | 67                                       |
| EUROTEMPLE                           | 305,306                                  |
| EVERGOOD                             | 55,12                                    |
| EVVA                                 | 55,56                                    |
| EXCEL                                | 56                                       |
| EXPRES                               | 56,65, 91, 92, 157                       |
| EZCURRA                              | 56,57, 117, 118, 306, 307                |
| EZSET                                | 86                                       |
| <b>F</b>                             |  |
| FAAB                                 | 170                                      |
| FAB                                  | 57,69, 170,171                           |
| FAC                                  | 7,30, 31, 58, 59, 84, 124, 127, 146, 307 |
| FACEF                                | 311                                      |
| FADE                                 | 74,112                                   |
| FAI                                  | 148                                      |
| FAICA                                | 171                                      |
| FAINER                               | 59                                       |
| FALCON                               | 21,59,149                                |
| FAMA                                 | 59                                       |
| FANA                                 | 26,59                                    |
| FARMA                                | 171                                      |
| FAS                                  | 59                                       |
| FAS - YALE                           | 286,287                                  |
| FASEM                                | 22,59                                    |
| FASMA                                | 55                                       |
| FAVOUR                               | 59                                       |
| FAYN                                 | 60,248                                   |
| FB                                   | 8  |
| FCV                                  | 60,85                                    |
| FEB                                  | 11,36, 82, 109, 161, 307                 |
| FECHADURA                            | 60                                       |
| FECOR                                | 46, 47, 334                              |
| FEDERAL                              | 60, 64, 65                               |
| FEFI                                 | 33                                       |
| FEL                                  | 119                                      |
| FEMSA                                | 171                                      |
| FERMABLOCK                           | 106                                      |
| FERMOD                               | 44                                       |
| FERONERIA                            | 60                                       |

| MARCA- MARKA- MAIN<br>MARQUE - MARKE | PÁG. - ORRIA - PAGE - PAGE - SEITE |
|--------------------------------------|------------------------------------|
| FETIS                                | 307                                |
| FF                                   | 60,61                              |
| FH                                   | 340                                |
| FHUR                                 | 80                                 |
| FIAM                                 | 248, 254, 308, 309                 |
| FIAT                                 | 171                                |
| FIC LOCKS                            | 61                                 |
| FICHET                               | 22, 61, 88, 130, 149, 287, 310     |
| FINSTRAL                             | 66                                 |
| FISAM                                | 171                                |
| FIST                                 | 62, 164, 171, 179, 223, 224        |
| FLAMBO                               | 50, 170                            |
| FLIETHER                             | 85                                 |
| FLIK                                 | 65                                 |
| FLOHR                                | 62                                 |
| FLORA                                | 62, 162, 171                       |
| FO                                   | 31, 32, 103                        |
| FONTAINE                             | 62, 113, 143                       |
| FORCE                                | 68                                 |
| FORD                                 | 171, 172, 173, 174, 175            |
| FORINDEX                             | 113,222                            |
| FORT                                 | 14, 36, 62, 77, 154, 162, 238      |
| FORTE                                | 62                                 |
| FORTIS                               | 63                                 |
| FORTRESS                             | 127                                |
| FOUR CIRCLE                          | 156, 157                           |
| FPB                                  | 109                                |
| FRAL                                 | 109                                |
| FREA                                 | 224                                |
| FRECOV                               | 33                                 |
| FRIPA                                | 63, 249                            |
| FROSER                               | 3, 113, 160, 222                   |
| FT                                   | 70                                 |
| FTH                                  | 3, 13, 63, 64, 65, 72, 129         |
| FUCHS                                | 41                                 |
| FUHR                                 | 33                                 |
| FULLEX                               | 65                                 |
| <b>G</b>                             |                                    |
| GABON                                | 65                                 |
| GAINSBOROUGH                         | 92,127                             |
| GALLUS                               | 65                                 |
| GAMMA                                | 104                                |
| GAMMET                               | 65                                 |
| GAON                                 | 84                                 |
| GARDIAN                              | 310                                |
| GARI                                 | 8                                  |
| GAS                                  | 175                                |
| GATO                                 | 65                                 |
| GAZ                                  | 236                                |
| GBS                                  | 150                                |
| GBZ                                  | 65                                 |
| GE GE                                | 6, 11, 27, 65, 66, 123             |
| GEBA                                 | 22, 23, 66                         |
| GEBRO                                | 43                                 |
| GEFI                                 | 6, 38, 39                          |
| GELBAU                               | 127                                |
| GELBON                               | 202, 203                           |
| GEM                                  | 36                                 |

| MARCA- MARKA- MAIN<br>MARQUE - MARKE | PÁG. - ORRIA - PAGE - PAGE - SEITE  |
|--------------------------------------|-------------------------------------|
| GEMINI                               | 82                                  |
| GEMM                                 | 87, 88                              |
| GENERAL MOTORS                       | 175, 176, 177, 178                  |
| GERA                                 | 66, 67, 117, 249                    |
| GERDA                                | 67                                  |
| GETE                                 | 6,38,39                             |
| GEVY                                 | 20,46                               |
| GEWIRU                               | 51                                  |
| GEWU                                 | 178                                 |
| GHE                                  | 178                                 |
| GIBBONS                              | 67                                  |
| GIESCHE                              | 33,85                               |
| GIMAST                               | 310                                 |
| GIMN                                 | 113                                 |
| GIOBERT                              | 167, 179, 180, 181, 182, 224, 234   |
| GIPIS                                | 310                                 |
| GIUSSANI                             | 67,68                               |
| GLAZIEV                              | 68                                  |
| GLOBE                                | 68,69                               |
| GLOSTAL                              | 65                                  |
| GMB                                  | 12                                  |
| GMG                                  | 310                                 |
| GODREJ                               | 69                                  |
| GOLD DOOR                            | 68, 69                              |
| GOLLOT                               | 113                                 |
| GOTZ                                 | 85                                  |
| GOYAL                                | 8                                   |
| GPZ                                  | 287                                 |
| GR                                   | 69                                  |
| GRAF                                 | 85                                  |
| GRAYHILL                             | 77                                  |
| GRUNDMANN                            | 65                                  |
| GSA                                  | 31                                  |
| GTV                                  | 6, 38, 39, 69, 80                   |
| GUARD                                | 69, 70, 74                          |
| GUARDIAN                             | 31, 60, 288                         |
| GUERVILLE R.                         | 70                                  |
| GUIDOTTI                             | 113                                 |
| GUITTEL                              | 4, 5                                |
| GUTLER                               | 119                                 |
| <b>H</b>                             |                                     |
| HÄFELE                               | 33, 34, 46, 47, 70, 72, 88, 89, 202 |
| HAGA                                 | 70                                  |
| HAIDE                                | 156, 157                            |
| HALLE                                | 70                                  |
| HAMA                                 | 182                                 |
| HAMPTON                              | 132                                 |
| HANNO                                | 33                                  |
| HARKOV                               | 71                                  |
| HARLEY DAVIDSON                      | 182                                 |
| HARLOC                               | 71, 127                             |
| HASLER                               | 117, 118                            |
| HAYWORTH                             | 71                                  |
| HB                                   | 71                                  |
| HBC                                  | 100                                 |
| HEAD                                 | 156, 157                            |
| HEGO                                 | 41                                  |
| HEKNA                                | 46, 47, 50, 71                      |

| MARCA- MARKA- MAIN<br>MARQUE - MARKE | PÁG. - ORRIA - PAGE - PAGE - SEITE  |
|--------------------------------------|---|
| HELCO-KFV                            | 249   |
| HELIX                                | 71  |
| HEMA                                 | 143   |
| HEMY                                 | 156, 157  |
| HENDERSON                            | 71, 288   |
| HERACLES                             | 64  |
| HERME                                | 71  |
| HERMES                               | 156, 157  |
| HERO                                 | 106   |
| HERPE                                | 127   |
| HERSEE                               | 20, 162   |
| HESTE                                | 41  |
| HEVY                                 | 28  |
| HILLMANN                             | 128   |
| HINO                                 | 233   |
| HK                                   | 162   |
| HOBBY                                | 55, 170   |
| HOBES                                | 72  |
| HOHRMANN                             | 22, 23, 33, 47, 65  |
| HONDA                                | 182, 183, 184, 185  |
| HOPPE                                | 28  |
| HORSE                                | 72  |
| HRG                                  | 106   |
| HSA                                  | 85  |
| HTEC                                 | 72  |
| HTV                                  | 72, 119   |
| HUDSON                               | 72, 185   |
| HUF                                  | 168, 172, 174, 185, 186, 187, 188, 189, 190, 191, 192, 193, 194, 195, 196 |
| HUNIT                                | 72  |
| HUTRA                                | 117   |
| HUWIL                                | 46, 47, 72, 73, 196   |
| HYMER                                | 55, 170   |
| HYUNDAI                              | 196, 197, 198   |
| <b>I</b>                             |   |
| I.R.                                 | 152   |
| IACAM                                | 180   |
| IBEAR                                | 73  |
| ICA                                  | 73  |
| ICSA                                 | 73, 90  |
| IDEAL                                | 47  |
| IDEAL SECURITY                       | 149   |
| IDM                                  | 311   |
| IFAM                                 | 18, 43, 63, 64, 73, 74, 78, 124   |
| IFOS                                 | 126, 127  |
| IGS                                  | 74  |
| IKON                                 | 43, 44, 74, 75, 76, 77  |
| ILARGI                               | 32, 77  |
| ILCO                                 | 77  |
| ILLINOIS                             | 20, 36, 77, 154, 162, 238   |
| ILS                                  | 77  |
| IMB                                  | 77  |
| IMBAC                                | 111   |
| IMP                                  | 3, 4, 5   |
| IMSA                                 | 191, 198, 199, 224  |
| INCECA                               | 78  |
| INDAK                                | 229   |
| INDAUX                               | 14  |



# ÍNDICE DE MARCAS

## BRAND INDEX

| MARCA- MARKA- MAIN<br>MARQUE - MARKE | PÁG. - ORRIA - PAGE - PAGE - SEITE                         |
|--------------------------------------|--|
| INGERSOLL                            | 78   |
| INLOC                                | 26   |
| INSTALL                              | 127  |
| INT                                  | 78   |
| IR                                   | 78   |
| ISEO                                 | 3, 32, 78, 79, 110, 136, 143, 235, 249, 289, 309, 311, 312 |
| ISKU                                 | 106  |
| ISSERSTEDT                           | 41   |
| ISUZU                                | 199  |
| ITAL                                 | 312  |
| ITEM                                 | 29   |
| ITO                                  | 6, 38, 39, 79  |
| IVANA                                | 79   |

### J

|              |                     |
|--------------|---------------------|
| JARDI        | 79, 80              |
| JD           | 11, 114, 161        |
| JET          | 3                   |
| JINLONG      | 80                  |
| JIP          | 80, 110, 111, 113   |
| JIS          | 80, 84              |
| JJ           | 44                  |
| JL           | 63                  |
| JMP          | 3, 6, 38            |
| JOHN DEERE   | 199                 |
| JOMA         | 31, 73, 74, 80, 120 |
| JORE         | 150                 |
| JOSTA        | 33                  |
| JOVI         | 7, 80               |
| JOWIL        | 69, 80, 81          |
| JPM          | 3, 81, 85           |
| JTF          | 81                  |
| JU           | 89, 144, 202        |
| JU JUNGINGER | 82                  |
| JUGODENT     | 174                 |
| JUNGHEINRICH | 82                  |
| JUNGST       | 80                  |
| JUNIE        | 82                  |
| JUNKUNC      | 82                  |
| JUWEL        | 313                 |
| JUZU         | 82                  |
| JVAL         | 82                  |

### K

|            |                  |
|------------|------------------|
| K+K        | 98               |
| KABA       | 82, 83           |
| KABS       | 83               |
| KALE       | 3, 83, 84, 313   |
| KALUGA     | 84               |
| KAMAZ      | 199              |
| KAP        | 84               |
| KARDEX     | 33, 113, 222     |
| KARO       | 64               |
| KASSBOHRER | 178              |
| KASSEL     | 314              |
| KATE       | 119              |
| KAWASAKI   | 199, 200         |
| KAWE       | 41, 42, 127, 149 |
| KAZAN      | 84, 85           |
| KEMEN      | 7, 8, 106        |

| MARCA- MARKA- MAIN<br>MARQUE - MARKE | PÁG. - ORRIA - PAGE - PAGE - SEITE |
|--------------------------------------|------------------------------------|
| KENWORTH                             | 200                                |
| KERBEROS                             | 314                                |
| KESO                                 | 85                                 |
| KEYA                                 | 2, 3, 160                          |
| KFV                                  | 85                                 |
| KIA                                  | 200, 201                           |
| KICHINEV                             | 85                                 |
| KIFER                                | 7                                  |
| KIFERM                               | 85, 88, 89, 112, 165, 202, 221     |
| KIMA                                 | 33                                 |
| KIND                                 | 28, 33                             |
| KIROVMACH                            | 86                                 |
| KITTY                                | 2                                  |
| KLIT                                 | 143, 235                           |
| KN                                   | 162                                |
| KNAPP                                | 33                                 |
| KOLB                                 | 163, 172, 173, 174, 175            |
| KOMATSU                              | 201                                |
| KP                                   | 86                                 |
| KRAMATORSK                           | 86                                 |
| KREMENCHUG                           | 86                                 |
| KREPISH                              | 315                                |
| KRESTI                               | 250, 251, 252                      |
| KROST                                | 30                                 |
| KUNERT                               | 38                                 |
| KURZEME                              | 315                                |
| KVR                                  | 31                                 |
| KWIKSET                              | 86                                 |
| KYMCO                                | 201                                |
| KYNNARPS                             | 86                                 |
| KYR                                  | 118                                |

### L

|              |                               |
|--------------|-------------------------------|
| LABOFA       | 66                            |
| LADA BAKONY  | 201, 202                      |
| LAFONTE      | 86                            |
| LAGRANDE     | 77                            |
| LAMA         | 100, 129                      |
| LAMPA        | 32                            |
| LANE         | 43                            |
| LAPERCHE     | 31, 86, 87, 88, 113, 114, 143 |
| LAPORTE      | 25, 88, 163, 222              |
| LAR          | 288, 332                      |
| LAREDO       | 63, 152                       |
| LARK         | 68, 88                        |
| LAS          | 88, 89, 112, 202              |
| LASBOLAGET   | 82, 89, 119, 288              |
| LEFEBURU     | 37                            |
| LEGALLAIS    | 71, 89                        |
| LEGGE        | 89                            |
| LEN-LOK      | 92                            |
| LEROY MERLIN | 79                            |
| LG           | 14                            |
| LINCE        | 11, 89, 90, 161, 315          |
| LINDE        | 162                           |
| LION         | 82                            |
| LIONA LIOX   | 113                           |
| LIPS         | 90, 91, 111                   |
| LISTA        | 47                            |

| MARCA- MARKA- MAIN<br>MARQUE - MARKE | PÁG. - ORRIA - PAGE - PAGE - SEITE    |
|--------------------------------------|---------------------------------------|
| LITTO                                | 13, 41, 91                            |
| LM                                   | 126                                   |
| LMP                                  | 202, 203                              |
| LOB                                  | 91, 92, 98, 157                       |
| LOCK                                 | 92                                    |
| LOCK-IT                              | 252                                   |
| LOCKSYS                              | 121                                   |
| LOCKWOOD                             | 92                                    |
| LOGO                                 | 92, 141                               |
| LORI                                 | 71                                    |
| LOTUS                                | 156, 157                              |
| LOWE & FLETCHER                      | 36, 55, 92, 93, 94, 95, 203, 204, 205 |
| LT                                   | 95                                    |
| LUCKY                                | 95                                    |
| LUCO                                 | 69                                    |
| LUMA                                 | 95                                    |
| LUME                                 | 67                                    |
| LUXOR                                | 127                                   |
| LYF                                  | 96                                    |
| <b>M</b>                             |                                       |
| M.LUNA                               | 2, 160                                |
| MACK                                 | 205                                   |
| MACOR                                | 336                                   |
| MAFOR                                | 113, 252                              |
| MAGNETI MARELLI                      | 179, 224, 226                         |
| MAGNUM                               | 96                                    |
| MARCADET                             | 88, 89, 202                           |
| MARIANI                              | 96                                    |
| MARK                                 | 133                                   |
| MARQUES                              | 96                                    |
| MARS                                 | 54                                    |
| MARUTI                               | 205                                   |
| MASTER                               | 41, 96, 97                            |
| MASTER LOCK                          | 97                                    |
| MASTERCRAFT                          | 127                                   |
| MATTEY                               | 125                                   |
| MAUER                                | 45                                    |
| MAUSER                               | 33, 72                                |
| MAVE                                 | 289                                   |
| MAXIGARD                             | 65                                    |
| MAXIM                                | 336                                   |
| MAXUS                                | 97                                    |
| MAZDA                                | 205, 206, 207                         |
| MBB                                  | 33                                    |
| MCL                                  | 97                                    |
| MCM                                  | 97, 98, 99, 288, 289, 315             |
| MD                                   | 78, 79                                |
| ME FA                                | 99                                    |
| MECALUX                              | 7, 46, 47                             |
| MECO                                 | 99                                    |
| MELSMETALL                           | 28, 99, 100                           |
| MENOVA                               | 47                                    |
| MERCURY                              | 167                                   |
| MERIT LINDE                          | 207                                   |
| MERKUR                               | 80                                    |
| MERMIER                              | 41, 43                                |
| MERONI                               | 100, 101                              |
| METAL                                | 101, 315, 316                         |

| MARCA- MARKA- MAIN<br>MARQUE - MARKE | PÁG. - ORRIA - PAGE - PAGE - SEITE   |
|--------------------------------------|--|
| METALCASTELLI                        | 71, 111  |
| METALCHIMEX                          | 127  |
| METALUX                              | 101, 127, 143  |
| METEOR                               | 22, 46, 47, 89, 101, 202   |
| METIZ                                | 101  |
| METTEM                               | 303  |
| MG MONTI                             | 101  |
| MIA                                  | 323  |
| MIAN                                 | 68   |
| MIBRA                                | 93, 204  |
| MICHEL SEAT                          | 101, 107   |
| MIGNON                               | 152  |
| MILA                                 | 101, 102   |
| MILES                                | 102  |
| MING TAY                             | 102  |
| MINI MOLA                            | 252  |
| MIRAGLIO                             | 224  |
| MISCELLANEOUS                        | 207  |
| MITSUBISHI                           | 207, 208, 209  |
| MIWA                                 | 102  |
| MLM                                  | 46, 47, 102, 103, 113, 124, 222  |
| MOBELLA                              | 103  |
| MODERN                               | 143  |
| MOFA                                 | 164  |
| MOFLEX                               | 106  |
| MOGILEV                              | 103  |
| MOIA                                 | 316  |
| MON                                  | 103  |
| MONACOR                              | 11, 161  |
| MONDIAL                              | 70, 113, 209   |
| MONOBLOC                             | 32, 103  |
| MOREAUX                              | 47, 49, 113, 148, 252  |
| MOSKVA                               | 289  |
| MOSKVITCH                            | 209  |
| MOSRENTGUEN                          | 103  |
| MOTTURA                              | 104, 316, 317, 318, 319  |
| MP                                   | 289  |
| MP PLODARI                           | 104  |
| MR                                   | 126  |
| MSM                                  | 104  |
| MST                                  | 31   |
| MSV                                  | 104, 252   |
| MUKRA                                | 41, 42   |
| MULTLOCK                             | 104, 105   |
| <b>N</b>                             |  |
| NABOB                                | 252  |
| NATIONAL CABINET                     | 105  |
| NB                                   | 6, 38 39 62  |
| ND                                   | 135, 136   |
| NEIMAN                               | 163, 165, 174, 175, 179, 180, 185, 187, 188, 194, 195, 196, 209, 210, 211, 212, 213, 214, 215, 216, 217, 218, 224, 225, 226, 235 |
| NEMEF                                | 33, 35, 41, 113, 222, 253, 340   |
| NEWMAN TONKS                         | 127  |
| NICO                                 | 63, 85   |
| NISSAN                               | 218, 219, 220, 221   |
| NOBO                                 | 47, 50, 169  |
| NORDWEST                             | 62, 117  |
| NOVA                                 | 105, 132   |

# ÍNDICE DE MARCAS

## BRAND INDEX

| MARCA- MARKA- MAIN<br>MARQUE - MARKE | PÁG. - ORRIA - PAGE - PAGE - SEITE |
|--------------------------------------|------------------------------------|
| NOVOFERM                             | 41                                 |
| NUMIDA                               | 54, 113                            |
| <b>O</b>                             |                                    |
| OAL                                  | 43, 67                             |
| OASA                                 | 289                                |
| OCARIZ                               | 105                                |
| OCTAVO M.                            | 105                                |
| ODA                                  | 13, 36                             |
| OFITA                                | 105                                |
| OIAUS                                | 9                                  |
| OJMAR                                | 33, 105, 106                       |
| OLIVA                                | 106                                |
| OLIVETTI                             | 107                                |
| OMA                                  | 107                                |
| OMEC                                 | 107, 319                           |
| OMIV                                 | 22, 107                            |
| OMR                                  | 101, 107                           |
| ONIUM                                | 138                                |
| ORBA                                 | 119                                |
| ORDO                                 | 88, 107, 202                       |
| ORENGO                               | 8, 289, 319, 333                   |
| ORION                                | 127                                |
| ORION NOVOX                          | 107                                |
| ORLANDO                              | 73                                 |
| ORO                                  | 108                                |
| ORONA                                | 244                                |
| ORSHA                                | 108                                |
| OSKO                                 | 80                                 |
| OSMET                                | 289                                |
| OSTMARK                              | 289                                |
| OTIS                                 | 74, 75, 77                         |
| <b>P</b>                             |                                    |
| P&C I.                               | 108                                |
| PADO                                 | 108                                |
| PANTHER                              | 80                                 |
| PAPAIZ                               | 108, 253                           |
| PAS                                  | 111                                |
| PASSEPARTOUT                         | 289                                |
| PASSY                                | 112                                |
| PASTORE                              | 110, 111                           |
| PATENT                               | 289                                |
| PATRONE                              | 319                                |
| PAYKAN                               | 128                                |
| PB                                   | 106                                |
| PC                                   | 22, 82, 109                        |
| PEBRA                                | 186                                |
| PENT                                 | 136                                |
| PENZMASH                             | 109                                |
| PERINO                               | 289                                |
| PEROHAUS                             | 50, 65, 66, 82, 178                |
| PERRIER                              | 70                                 |
| PETERBORO                            | 51                                 |
| PETROZAVODSK                         | 109                                |
| PFÄFFENHAIN                          | 109, 110                           |
| PGO                                  | 221                                |
| PH                                   | 136                                |
| PHILLIPS                             | 25, 110                            |
| PHOENIX                              | 110                                |

| MARCA- MARKA- MAIN<br>MARQUE - MARKE | PÁG. - ORRIA - PAGE - PAGE - SEITE   |
|--------------------------------------|--------------------------------------|
| PICARD                               | 21, 110                              |
| PICARDIE                             | 6, 1295                              |
| PJ                                   | 89, 113, 165, 202, 221, 222          |
| PK                                   | 89, 202                              |
| PLUS                                 | 5                                    |
| PM                                   | 113                                  |
| POLAR                                | 163                                  |
| POLLAK                               | 222                                  |
| POLLUX                               | 110                                  |
| POS                                  | 162, 178, 222                        |
| POTENT                               | 101, 110, 320, 321                   |
| PP                                   | 44                                   |
| PAZIS                                | 254                                  |
| PREFER                               | 106, 110, 111, 321, 336              |
| PREMI                                | 100                                  |
| PRESTA                               | 25, 163, 222                         |
| PROAUTO                              | 3, 160                               |
| PROBAT                               | 63                                   |
| PROGRES                              | 62                                   |
| PROMO                                | 110, 111                             |
| PROTEC                               | 31                                   |
| PZ                                   | 22, 23                               |
| <b>Q</b>                             |                                      |
| QCM                                  | 44, 135                              |
| QCP                                  | 31                                   |
| <b>R</b>                             |                                      |
| RADIAL                               | 144, 145                             |
| RAM                                  | 156, 157                             |
| RAUCO                                | 71                                   |
| REDY                                 | 92                                   |
| REGAL                                | 111                                  |
| REGENT                               | 71                                   |
| REMO                                 | 73                                   |
| RENAG                                | 290                                  |
| RENZ                                 | 46, 47, 88, 89, 111, 112, 202        |
| REVI                                 | 321                                  |
| REX                                  | 112, 290                             |
| RGM                                  | 112                                  |
| RIAZIAN                              | 112                                  |
| RICOUARD                             | 112                                  |
| RIGA                                 | 112                                  |
| RIGAL                                | 322                                  |
| RIL                                  | 112, 349                             |
| RIPA                                 | 74, 112                              |
| RITA                                 | 112                                  |
| RITTAL                               | 28, 29                               |
| RIV                                  | 135                                  |
| ROC                                  | 63, 152                              |
| RONEO                                | 7, 113, 146, 222                     |
| RONIS                                | 87, 88, 113, 114, 202, 222, 223, 252 |
| ROOL A DOOR                          | 18                                   |
| ROOTES                               | 204                                  |
| ROS                                  | 202, 203                             |
| ROSS                                 | 165, 223                             |
| ROSSETTI                             | 114                                  |
| ROTO                                 | 28, 67                               |
| ROYAL                                | 4, 5, 114, 147, 156, 157             |
| RS                                   | 106                                  |

| MARCA- MARKA- MAIN<br>MARQUE - MARKE | PÁG. - ORRIA - PAGE - PAGE - SEITE |
|--------------------------------------|------------------------------------|
| RST                                  | 25                                 |
| RUBEN                                | 322, 333, 336                      |
| RUE                                  | 333                                |
| RUFFINI                              | 224                                |
| RUKA                                 | 46, 47, 144                        |
| RUKO                                 | 114, 115                           |
| RUNO                                 | 171                                |
| RUSSIA                               | 115                                |
| RUSSWIN                              | 115                                |
| RUTALCHI                             | 8                                  |
| <b>S</b>                             |                                    |
| SAAB                                 | 223                                |
| SAB                                  | 323                                |
| SABT                                 | 116                                |
| SADV                                 | 27, 113, 222                       |
| SAFE                                 | 182, 198, 199, 223, 224, 226, 323  |
| SAG                                  | 305, 306, 311                      |
| SAM                                  | 116, 323                           |
| SAMSONITE                            | 116                                |
| SANCHUN                              | 156, 157                           |
| SANEL                                | 113, 222                           |
| SANPEUR                              | 145                                |
| SANTIS                               | 33                                 |
| SANTOS                               | 107, 109                           |
| SANY                                 | 11, 161                            |
| SARGENT                              | 116                                |
| SATURN                               | 20, 117                            |
| SCHAFFER                             | 222                                |
| SCHARER                              | 117                                |
| SCHARF                               | 72                                 |
| SCHLAGE                              | 18, 117                            |
| SCHLECHTENDAHL                       | 117                                |
| SCHLEGEL                             | 46, 47                             |
| SCHRITT                              | 77                                 |
| SCHUCO                               | 3, 6, 38, 39, 85, 117              |
| SCOVILL                              | 18                                 |
| SCUDO                                | 9                                  |
| SE                                   | 70, 127                            |
| SEA                                  | 117, 118                           |
| SECURE                               | 122                                |
| SECUREMME                            | 118, 323, 324                      |
| SECURIKEY                            | 54, 100                            |
| SECURITAL                            | 62, 118                            |
| SEEBURG                              | 77                                 |
| SEIMA                                | 202, 203                           |
| SELECT                               | 118                                |
| SELIVANOVSK                          | 118                                |
| SEMEL                                | 80, 123                            |
| SEN                                  | 85                                 |
| SENTRY SAFE                          | 118                                |
| SERMEC                               | 324                                |
| SERRALLER                            | 8, 44, 73, 118, 124, 337           |
| SERRETA                              | 118, 349                           |
| SES                                  | 127                                |
| SESA                                 | 113, 114                           |
| SEZAN                                | 156, 157                           |
| SHANGAI                              | 119                                |
| SHAW                                 | 119                                |

| MARCA- MARKA- MAIN<br>MARQUE - MARKE | PÁG. - ORRIA - PAGE - PAGE - SEITE   |
|--------------------------------------|--------------------------------------|
| SHILUTE                              | 119                                  |
| SHOWA                                | 116                                  |
| SIAM                                 | 31, 119                              |
| SIAS                                 | 324                                  |
| SIB                                  | 32, 90                               |
| SIBI                                 | 324, 325, 337                        |
| SIDERAL                              | 325                                  |
| SIDESE                               | 119                                  |
| SIDLEEN                              | 56                                   |
| SIEBAU                               | 33, 130                              |
| SIL                                  | 59, 120, 139                         |
| SIMATIC                              | 119                                  |
| SIMECA                               | 67, 119                              |
| SIMPLEX                              | 113, 222, 224, 225, 226, 235         |
| SINJET                               | 47                                   |
| SIPEA                                | 179, 180, 181, 224, 226              |
| SIS                                  | 119, 120                             |
| SISO                                 | 31, 56, 106, 120                     |
| SISPA                                | 222, 226                             |
| SJL                                  | 120                                  |
| SKILMANN                             | 42                                   |
| SMET                                 | 289                                  |
| SOFER                                | 120                                  |
| SOFI SONAFI                          | 120                                  |
| SOLER                                | 120                                  |
| SOLID                                | 33                                   |
| SOLOR                                | 114                                  |
| SONICO                               | 40                                   |
| SOPRANO                              | 120                                  |
| SOS                                  | 31, 65, 121, 127, 252                |
| SP                                   | 64                                   |
| SPEEDAL                              | 33, 35                               |
| SPIDER                               | 121                                  |
| SQUIRE & SONS                        | 121, 122                             |
| SS                                   | 33                                   |
| SSANGYONG                            | 226                                  |
| STA LOCK                             | 122                                  |
| STAM                                 | 60                                   |
| STANDARD                             | 6, 38, 39                            |
| STAR                                 | 122                                  |
| STARLET                              | 122                                  |
| STEELCASE                            | 36, 72, 196                          |
| STEIGA                               | 47                                   |
| STEKLOMASH                           | 122                                  |
| STEM                                 | 123                                  |
| STERLING                             | 123                                  |
| STIQAM                               | 31, 135                              |
| STIQUAM                              | 289                                  |
| STRAFOR                              | 72, 88, 113, 114, 196, 202, 222, 223 |
| STRATTEC                             | 173                                  |
| STREBOR                              | 123, 203, 227                        |
| STREMLER                             | 25, 31, 41, 113, 143                 |
| STS                                  | 30, 46, 47, 51, 123, 124, 127, 227   |
| STUBLINA                             | 124                                  |
| STUMPF                               | 124                                  |
| STUMPF METALL                        | 106                                  |
| STUV                                 | 33, 47, 51, 102, 103, 113, 124, 125  |
| STV                                  | 107                                  |
| SUBARU                               | 227                                  |

# ÍNDICE DE MARCAS

## BRAND INDEX

| MARCA - MARKA - MAIN<br>MARQUE - MARKE | PÁG. - ORRIA - PAGE - PAGE - SEITE |
|--|------------------------------------|
| SUF                                    | 63                                 |
| SUKI                                   | 62                                 |
| SUL                                    | 41                                 |
| SUREX                                  | 125                                |
| SURFINOR                               | 61                                 |
| SUYOKA                                 | 7                                  |
| SUZUKI                                 | 227, 228, 229                      |
| SWAN                                   | 156, 157                           |
| SWEDA                                  | 111                                |
| <b>T</b>                               |                                    |
| TAITO                                  | 125                                |
| TALLINN                                | 125                                |
| TANLOCKS                               | 89                                 |
| TAP-AGIS                               | 229                                |
| TARONI                                 | 126                                |
| TAS                                    | 21                                 |
| TATA                                   | 229                                |
| TAYLOR                                 | 126, 127                           |
| TAYMOR                                 | 127                                |
| TECHNAL                                | 127                                |
| TECNO                                  | 73, 138, 196                       |
| TECNOLAR                               | 124                                |
| TECNOR                                 | 61                                 |
| TECON                                  | 126                                |
| TECSESA                                | 124, 126, 325                      |
| TECUMSEH                               | 229                                |
| TEICOCIL                               | 59, 126, 127, 132                  |
| TEKA                                   | 15, 126                            |
| TELFORD                                | 93, 203                            |
| TEM                                    | 74, 126                            |
| TERCA                                  | 8                                  |
| TESA                                   | 3, 74, 78, 126, 127, 147, 247, 290 |
| TESIO                                  | 4, 325                             |
| TESTA                                  | 31                                 |
| TH                                     | 128                                |
| THOMAS LAIDLAW                         | 127                                |
| THONE                                  | 41                                 |
| THT                                    | 72                                 |
| TIBBE                                  | 187, 229                           |
| TICINO                                 | 128                                |
| TIEFENTHAL                             | 53, 69, 80                         |
| TIFON                                  | 128                                |
| TIGRIS                                 | 128                                |
| TITAN                                  | 86, 128, 129, 229                  |
| TITANO                                 | 326                                |
| TITUS                                  | 152                                |
| T-KEY                                  | 125                                |
| TM                                     | 47                                 |
| TOK                                    | 22, 237                            |
| TOK WINKHAUS                           | 130, 131, 237                      |
| TOKAJ RIKA                             | 177, 230, 231, 232, 233            |
| TOMSK                                  | 132                                |
| TOOL BOX                               | 229, 230                           |
| TOP                                    | 105, 132                           |
| TOPLOCK                                | 127                                |
| TOVER                                  | 20, 63, 132, 326                   |
| TOY                                    | 2                                  |
| TOYOTA                                 | 230, 231, 232, 233                 |

| MARCA - MARKA - MAIN<br>MARQUE - MARKE | PÁG. - ORRIA - PAGE - PAGE - SEITE                                    |
|--|---|
| TRAMA                                  | 223, 224  |
| TRAVEX                                 | 132   |
| TREE                                   | 39  |
| TRELOCK                                | 130, 131, 132, 144, 233, 237  |
| TRI CIRCLE                             | 52, 133   |
| TRI STAR                               | 134   |
| TRIMARK                                | 134   |
| TRINITY                                | 102   |
| TRIO                                   | 134   |
| TRIO-VING                              | 134, 246, 290, 291, 292   |
| TRITON                                 | 33, 80  |
| TRIUMPH MOTORCYCLE                     | 233   |
| TROMER                                 | 98, 101, 132  |
| TRUMPH                                 | 128   |
| TRUPER                                 | 134, 135  |
| TRW-SIPEA                              | 234   |
| TRYBA                                  | 56  |
| TSAG                                   | 135   |
| TUFF                                   | 253   |
| TULA                                   | 135   |
| TÜRSCHLOSS                             | 21  |
| TUSHINO                                | 135, 326  |
| TUTIS                                  | 53  |
| TZAFRER                                | 37, 65, 135   |
| <b>U</b>                               |   |
| UBE                                    | 185, 186, 188, 194, 195   |
| UCEM                                   | 44, 135, 136, 146, 292  |
| ULIANOVSK                              | 136   |
| ULTRA                                  | 93, 94, 204   |
| UMF                                    | 136   |
| UNIFOR                                 | 110   |
| UNION                                  | 92, 93, 137, 138, 203, 204, 227, 234, 292                             |
| UNIPART                                |   |
| UNIVERSAL                              | 138, 139, 140, 141, 142, 253  |
| URBIS                                  | 142   |
| URKO                                   | 142, 349  |
| US                                     | 82  |
| UTZ                                    | 93, 119, 204  |
| <b>V</b>                               |   |
| VACHETTE                               | 78, 79, 86, 88, 129, 130, 143, 144, 145, 146, 224, 225, 235, 236, 340 |
| VAGO                                   | 111   |
| VALEO                                  | 217, 219, 220, 232, 236   |
| VARIOS                                 | 146   |
| VAUGHN                                 | 72, 119   |
| VBH                                    | 146   |
| VDO                                    | 189   |
| VEGA                                   | 13, 113, 146  |
| VELO                                   | 156, 157  |
| VENDI                                  | 146, 147  |
| VENLOCK                                | 127   |
| VERA                                   | 117   |
| VERSCO                                 | 41  |
| VG F VILLATORE                         | 147   |
| VIDMAR                                 | 117, 118  |
| VIKI                                   | 47  |
| VILLFER                                | 333   |
| VINCO                                  | 143, 144  |

| MARCA- MARKA- MAIN<br>MARQUE - MARKE | PÁG. - ORRIA - PAGE - PAGE - SEITE |
|--------------------------------------|------------------------------------|
| VING                                 | 147                                |
| VIP                                  | 31                                 |
| VIRO                                 | 2, 147, 148, 240                   |
| VISO                                 | 156, 157                           |
| VISONIC                              | 11, 161                            |
| VOKO                                 | 33, 80                             |
| VOLGA                                | 236                                |
| VOLGOGRAD                            | 148                                |
| VOLKOVYSK                            | 148                                |
| <b>W</b>                             |                                    |
| WALE                                 | 152                                |
| WALLY                                | 148                                |
| WALRUS                               | 148, 149                           |
| WANJIN                               | 149                                |
| WASO                                 | 33, 162, 174, 218, 220, 236, 237   |
| WEBER                                | 149                                |
| WEBSTER                              | 149                                |
| WECO                                 | 22, 33, 149, 152, 178              |
| WEDO                                 | 54                                 |
| WEISER                               | 59, 149                            |
| WELKA                                | 149, 326                           |
| WEPA                                 | 80                                 |
| WESCO                                | 162                                |
| WESLOCK                              | 149                                |
| WEST LOCK                            | 150, 237                           |
| WHITCO                               | 150                                |
| WIGRO                                | 150                                |
| WILKA                                | 150, 151                           |
| WILLENHALL                           | 67                                 |
| WILMOT BREEDEN                       | 204, 205                           |
| WINFIELD                             | 156, 157                           |
| WINKHAUS                             | 151                                |
| WINLOCK                              | 151                                |
| WINNER                               | 65, 70                             |
| WIREROPE                             | 151                                |
| WITTE                                | 185, 186, 187, 188, 194, 195, 237  |
| WMS                                  | 152, 292                           |
| WOC                                  | 63, 152                            |
| WSM                                  | 28                                 |
| WT                                   | 152                                |

| MARCA- MARKA- MAIN<br>MARQUE - MARKE | PÁG. - ORRIA - PAGE - PAGE - SEITE   |
|--------------------------------------|--|
| <b>Y</b>                             |  |
| YAC                                  | 113, 222   |
| YALE                                 | 20, 22, 23, 40, 63, 119, 152, 153, 154, 155, 156, 162, 165, 166, 237, 238, 253, 254, 292, 327, 349 |
| YALTRES                              | 25, 63   |
| YAMAHA                               | 238, 239, 240  |
| YANEDIS                              | 54   |
| YARD                                 | 157  |
| YARDENI                              | 156, 157   |
| YEMAR                                | 127, 136   |
| YETI                                 | 92, 98, 156, 157   |
| YMOS                                 | 174, 179, 185, 188, 190, 191, 192, 193, 215, 216, 223  |
| YUGO                                 | 240  |
| YUN HUAN                             | 157  |
| YVEL                                 | 112, 170   |
| YWS                                  | 157, 240   |
| <b>Z</b>                             |  |
| ZADI                                 | 157, 158, 233, 240, 241  |
| ZAIN                                 | 17, 18   |
| ZANI                                 | 73   |
| ZAZ                                  | 236  |
| ZECE                                 | 41   |
| ZEISS IKON                           | 254, 255   |
| ZENI                                 | 32, 158  |
| ZENICA                               | 31   |
| ZENITH                               | 31, 32, 119  |
| ZIL                                  | 199, 241   |
| ZUNDAPP                              | 178  |

# ***LLAVES PLANAS PARA CERRADURAS DE CILINDRO***

*SARRAILA ZILINDRIKOTARAKO GILTZA ZAPALAK*

*CYLINDER KEYS*

*CLES POUR CYLINDRES*

*ZYLINDERSCHIÜSSEL*



***THE KEY TO EXCELLENCE***

*GLOBALLY UNLOCKING MILLIONS OF DOORS DAILY*





45

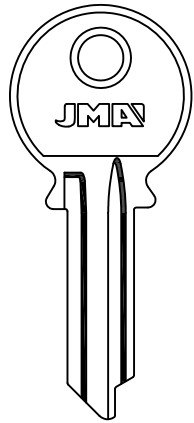
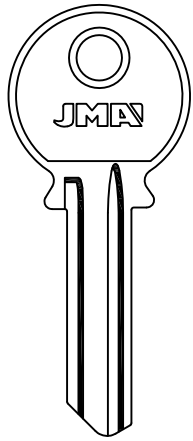

303

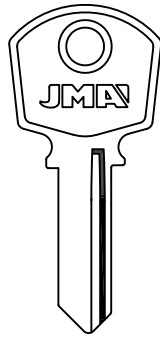

333

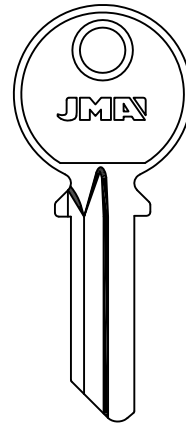

PARA-FOR:

45 (RUS)

303 (RC)

333 (IL)

3M (PRC)

A.M. BARAS (GB)

ABA (SF)

ABC (E)

333

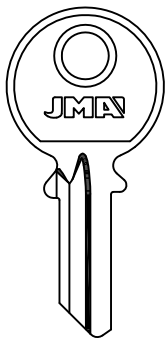

3M

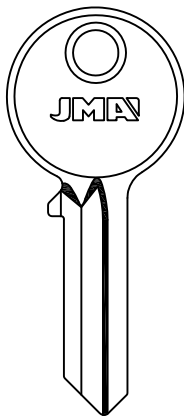

A.M. BARAS

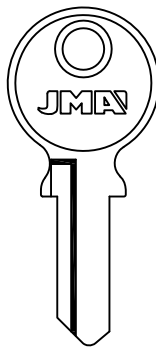

ABA

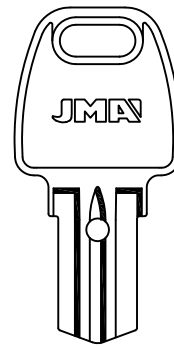

LAT.

ABC

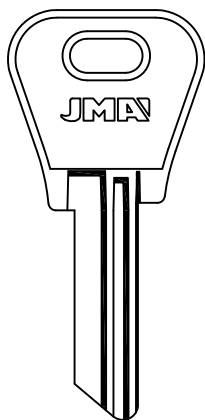

BAGEM

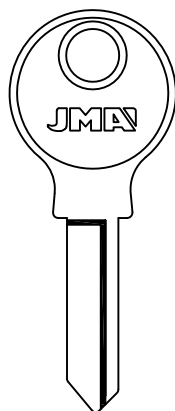

BAGEM

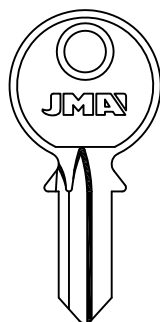

BAGEM

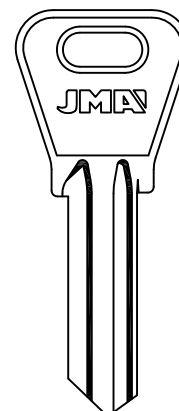

BAGEM











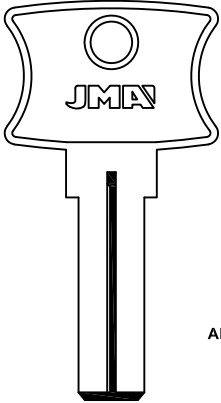
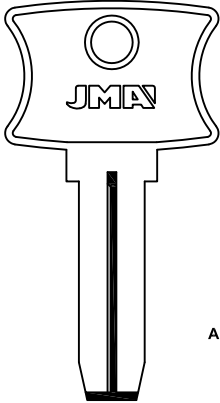
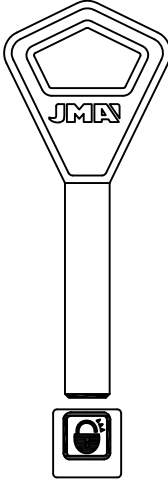
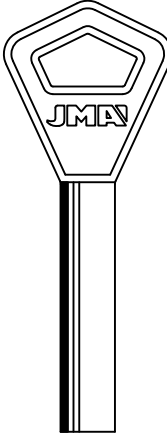



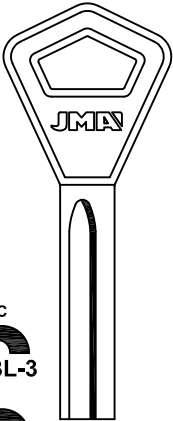
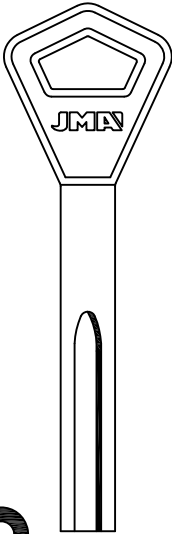
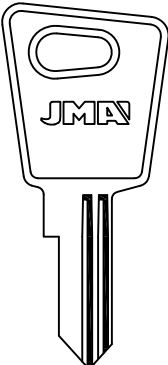
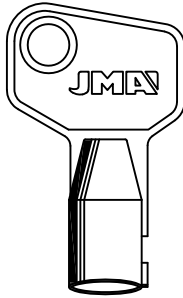





BAGEM

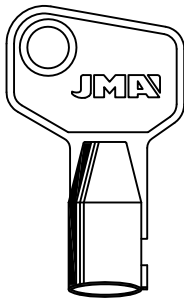
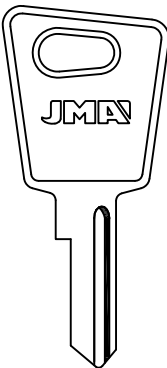
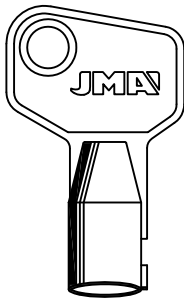
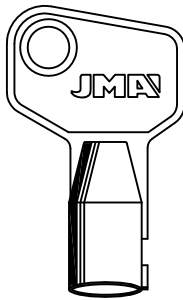
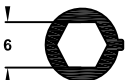

**PARA-FOR:**

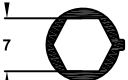
- ABC (E)
- ABLOY (SF)
- ABSA (E)

| ABC   |   | ABLOY   |   |
|---|---|---|---|
|    |    |    |    |
| ALP.  | ALP.  | LAT.<br>ACE.  | LAT.  |
|    |    |    |    |
| ABC-6<br>BAGEM  | ABC-7<br>BAGEM  | ABL-1<br>KITTY-VIRO   | ABL-2   |
| ABLOY   |   | ABSA  |   |
|   |   |   |   |
| LAT.  | LAT.  |   | ZAM.  |
|  |  |   |  |
| ABL-3   | ABL-5   | AB-11<br>M.LUNA   | AB-1T<br>KEYA   |
|  |   |  |   |
| ABL-4   |   | AB-1D   |   |
|  |   |   |   |
| ABL-6   |   | AB-21   |   |
|  |   |  |   |
| RAB<br>ABL-6  |   | AB-2D   |   |
| ABSA  |   |   |   |
|  |  |   |  |
| ZAM.  |   | ZAM.  | ZAM.  |
|  |  |  |  |
| AB-2T<br>KEYA-TOY   | AB-3I<br>M.LUNA   | AB-3T<br>KEYA   | AB-4T<br>KEYA   |



## ABSA

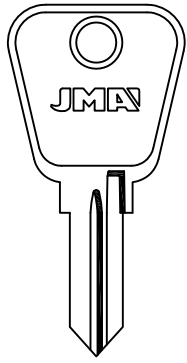

14  
AB-5I

13  
AB-5D

FROSER

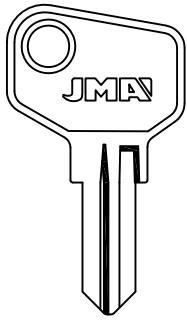

15  
AB-6I

PROAUTO

AB-6D



14  
AB-8I

ARREGUI

13  
AB-8D

ARFE-FROSER-KEYA

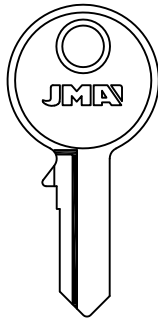

8  
AB-9D

KEYA

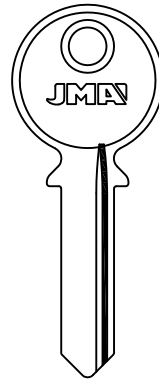

AB-11

KEYA

PARA-FOR:

ABSA (E)

ABUS (D)

## ABUS

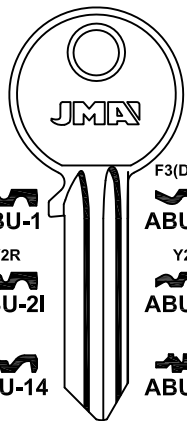

ABU-1

Y2R  
ABU-2I

ABU-14

ABU-44

ABU-46

F3(D)-Y1  
ABU-1D

Y2L  
ABU-2D

ABU-7D

ABU-43D

ABU-46D

R008  
ABU-49

ABU-53

X4S  
ABU-55

ABU-67

ABU-69

ABU-74

X2S  
ABU-76

ABU-52D

ABU-55D

ABU-67D

ABU-71D

ABU-74D

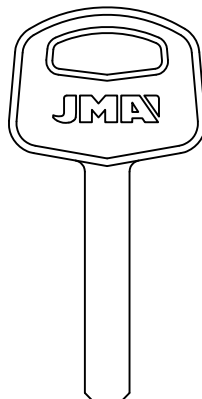

GRANIT

ABU-3

BULIT

LAT.

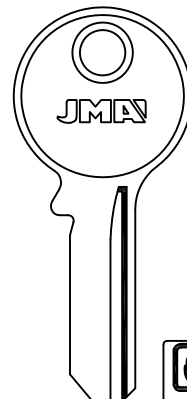

ABU-4I

ABU-4D

ABU-15

ABU-15D

ANCHOR-JET-JMP-KALE-TESA

CISA-ISEO-JPM-SCHUCO

## ABUS

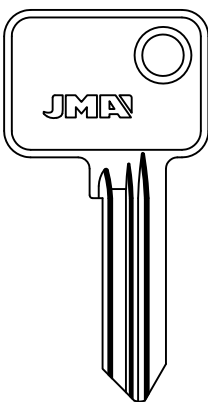

ABU-5D

ABU-6I

ABU-6D

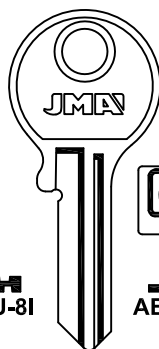

ABU-8I

ABU-12I

ABU-20

ABU-47



ABU-8D

ABU-12D

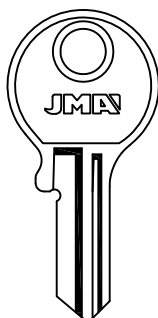

ABU-9I

ABU-9D

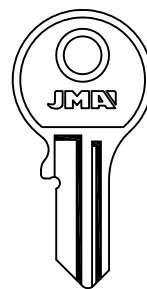

ABU-10I

ABU-10D



ABU-37D

ANCHOR-FTH-IMP

**JMA**<sup>®</sup>

Copyright by Alejandro Altuna S.A. 2014









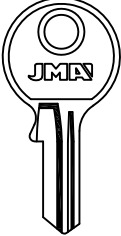
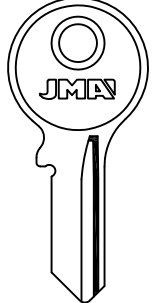
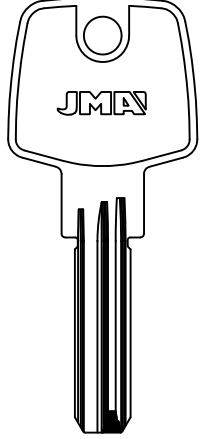

ATENCIÓN: Concerniente a las marcas y denominaciones comerciales ver nota en índice.  
 ATTENTION: Concerning the marks and commercial denominations see note in index.  
 ATTENTION: Concernant les marques et dénominations commerciales voir la note dans l'index.  
 ACHTUNG: Beziehen auf die marke und handelsname sehen sie die notiz im index.

**PARA-FOR:**

ABUS (D)

**ABUS**

CISA

ABU-11 ABU-11D



ABU-13 ABU-13D

ABU-21  
ANCHOR-BURG  
GUITTEL-IMP-ROYAL

LAT.

7.35  
AAL  
2.35  
ABU-16  
EXTRA CLASSE  
CISA-BRICARD

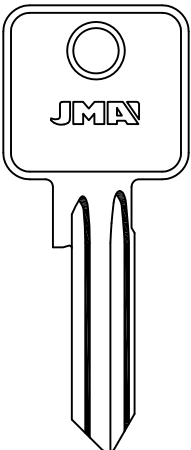
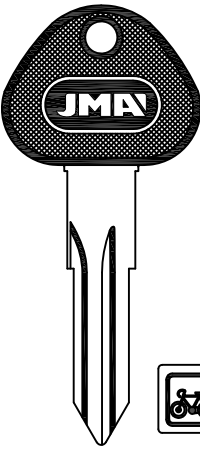
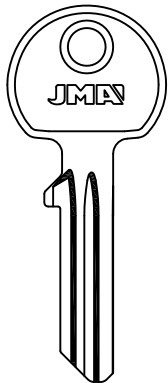
**ABUS**

\* LAT.

ABU-48

K1D  
ABU-70

ABU-77

ABU-80

ABU-83

X4S  
\* ABU-85

Z71....1-1043  
Z72....1-1043

Z71....1-1043  
Z72....1-1043

CISA

ABU-17 ABU-17D

\* ABU-85



ABU-18.P ABU-18D.P

ABU-19D

BUFFO

BUFFO

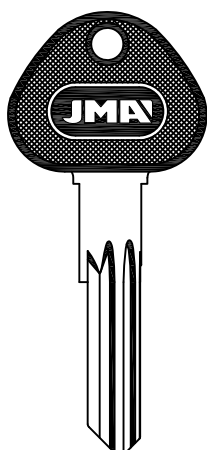
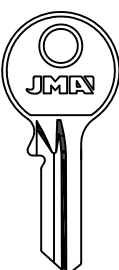
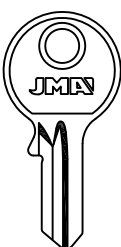
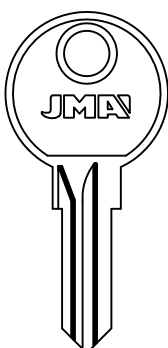
**ABUS**

Z71....1-1043  
Z72....1-1043

ABU-19.P ABU-19D.P

ABU-22D

ABU-23D

ABU-24D

BUFFO

CISA



## ABUS

PARA-FOR:

ABUS (D)

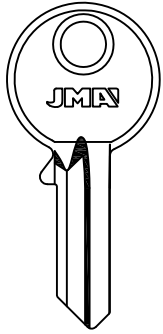

ABU-25D

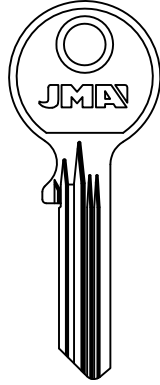

ABU-26D

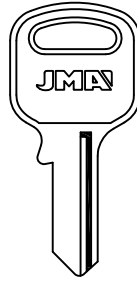

ABU-27

ABU-27D

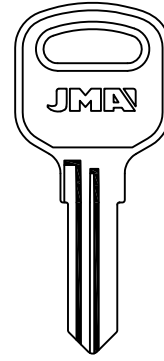

ABU-28



CISA

ARMSTRONG-BUFFO

## ABUS

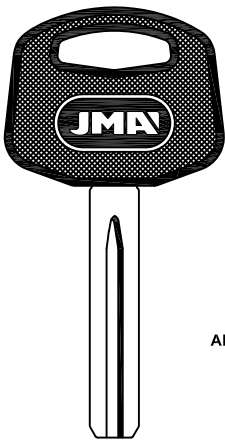

ABU-29.P

PLUS

ALP.

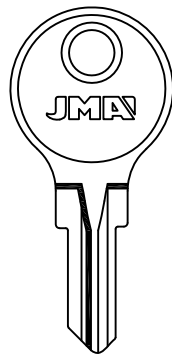

ABU-30

ABU-30D

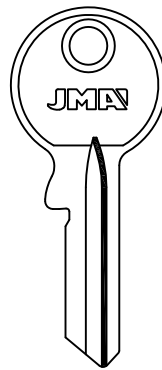

ABU-32D

ANCHOR-IMP

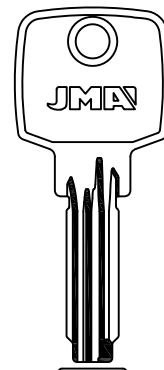

ABU-34

LAT.



30-40

EC 75

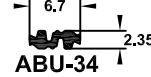

## ABUS

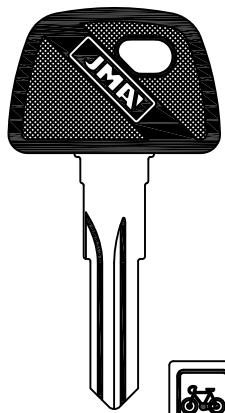

X61... 1-331 V61...  
X62... V62...  
ABU-35.P ABU-36.P

BUFFO

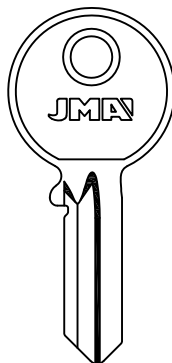

ABU-38D



40-50-60

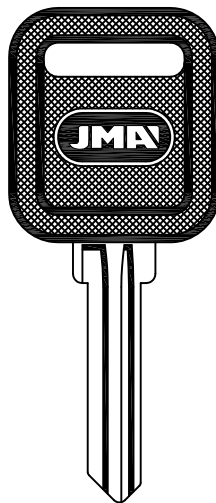

ABU-39.P

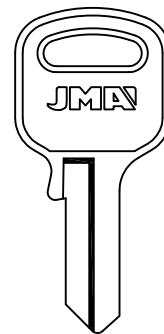

ABU-45



ABU-40

ANCHOR-BURG-GUITTEL  
IMP-ROYAL

**JMA**<sup>®</sup>

Copyright by Alejandro Altuna S.A. 2014



ATENCIÓN: Concerniente a las marcas y denominaciones comerciales ver nota en índice.  
ATTENTION: Concerning the marks and commercial denominations see note in index.  
ATTENTION: Concernant les marques et dénominations commerciales voir la note dans l'index.  
ACHTUNG: Beziehen auf die marke und handelsname sehen sie die notiz im index.

PARA-FOR:

ABUS (D)

ABUS

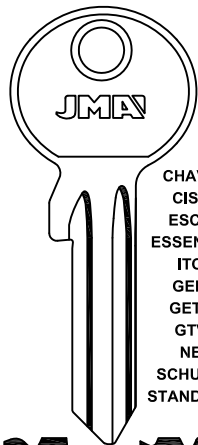

ABU-41 ABU-41D



ABU-68

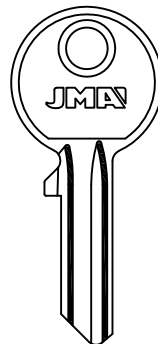

...1-342  
EF...1-724  
B...1-342  
EE...1-724  
ABU-42

E....  
ER....  
801-1236  
ABU-42D

BUFFO-CISA

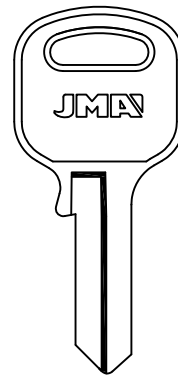

ABU-60 ABU-50

ANCHOR-JMP

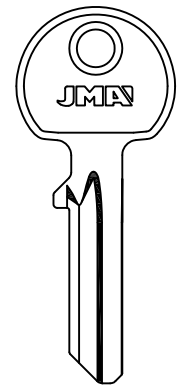

ABU-51D

ABUS

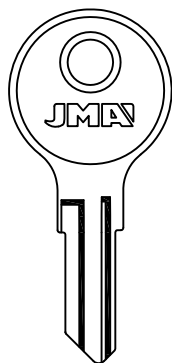

ABU-54 ABU-54D

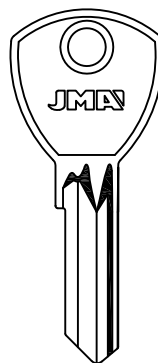

ABU-57 ABU-57D

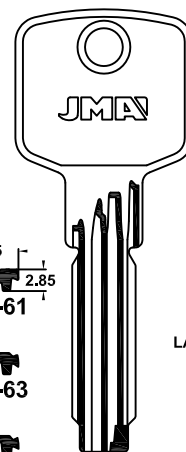

ABU-61  
ABU-63  
ABU-66

LAT.

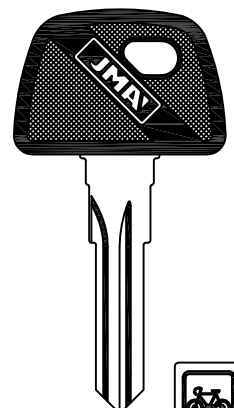

U72  
ABU-64.P

W71  
ABU-65.P

ABUS

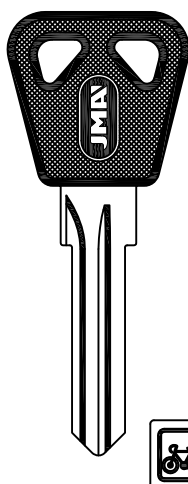

ABU-72.P

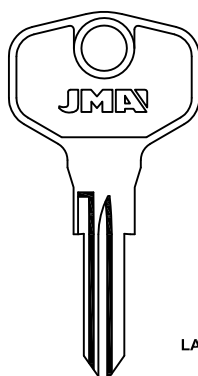

LAT.

ABU-73D

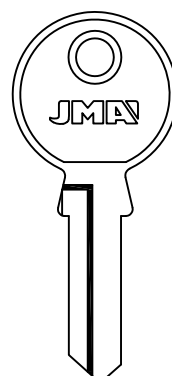

ABU-75D

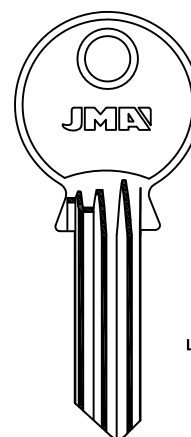

004  
ABU-78

GE GE

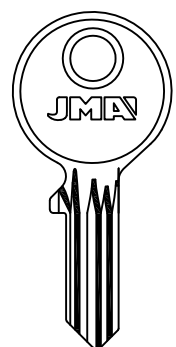

AL  
ABU-79

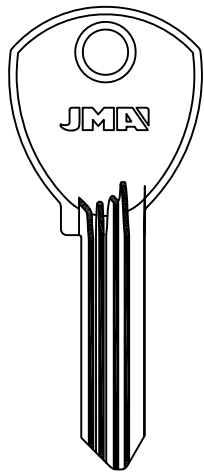
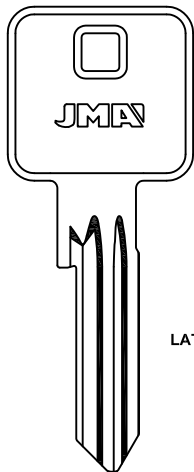

**ABUS**  
ABU-84D  
ABU-86D

LAT.

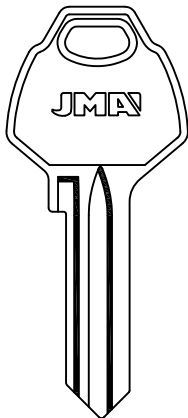
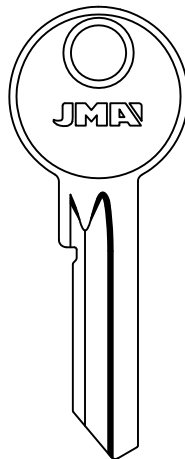
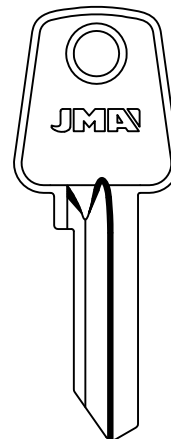
**ADAMSRITE**  
ADS-1D**AEP**  
AEP-1D  
AEP-2D**PARA-FOR:**

ABUS (D)

ADAMSRITE (GB)

AEP (RUS)

AGA (E)

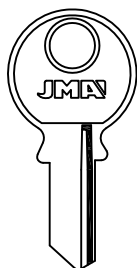
**AGA**

T1

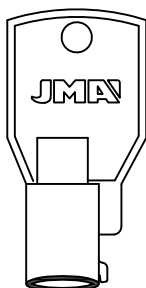
  
AGA-1I

AGA-1T

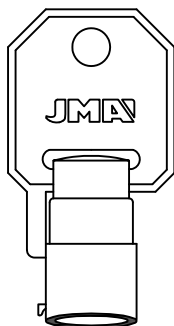

AGA-2T

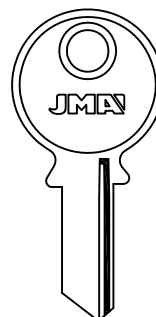

AGA-3I

LAT.

LAT.

FAC-KEMEN-KIFER-RONEO

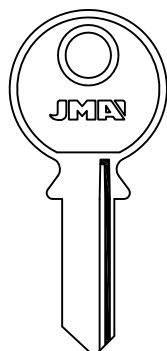
**AGA**

AGA-4I



AGA-4D

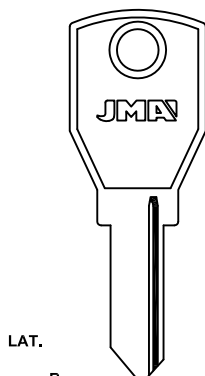

LAT.

B

901-926

  
AGA-5I

D

901-926

  
AGA-6I

LAT.

A

901-926

  
AGA-5D

C

901-926

  
AGA-6D

B

501-526

  
AGA-18I

D

501-526

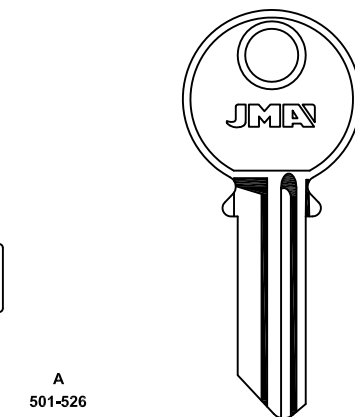
  
AGA-19I

A

501-526

  
AGA-18D

C

501-526

  
AGA-19D  
AGA-7

MECALUX-SUYOKA

JOVI

**JMA**<sup>®</sup>

Copyright by Alejandro Altuna S.A. 2014



ATENCIÓN: Concerniente a las marcas y denominaciones comerciales ver nota en índice.  
 ATTENTION: Concerning the marks and commercial denominations see note in index.  
 ATTENTION: Concernant les marques et dénominations commerciales voir la note dans l'index.  
 ACHTUNG: Beziehen auf die marke und handelsname sehen sie die notiz im index.

**PARA-FOR:**

AGA (E)

**AGA**

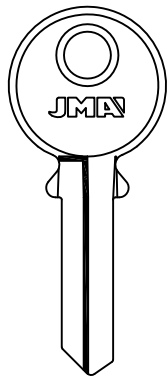

**AGA-8D**

GOYAL-KEMEN

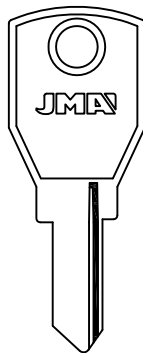

**AGA-9I**

**AGA-23**

ARREGUI-ALFA-GARI  
ORENGO-RUTALCHI-SERRALLER

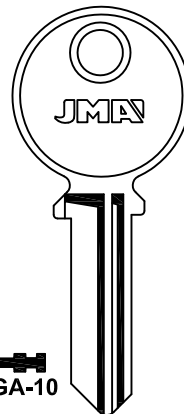

**AGA-10**

**AGA-13I**

**AGA-22**

GARI

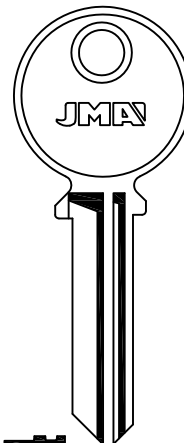

**AGA-11**

**AGA-14D**

GARI

**AGA**

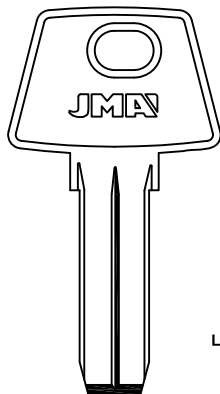

LAT.

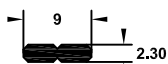

**AGA-12**

COLOMENCA-FB  
SERRALLER-TERCA

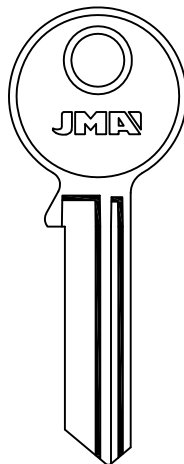

**AGA-15**

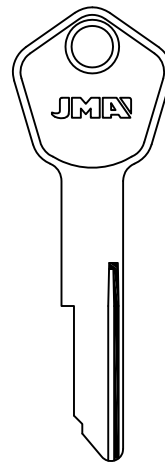

**AGA-16I**

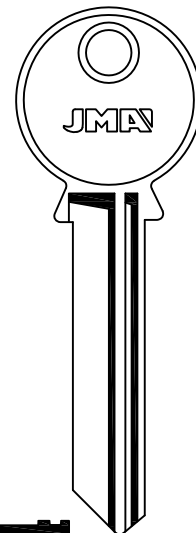

**AGA-20**

SERRALLER

**AGA**

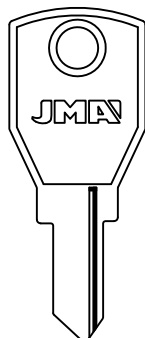

**AGA-24I**

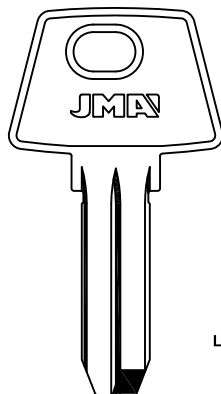

**AGA-24D**



**AGA-25**

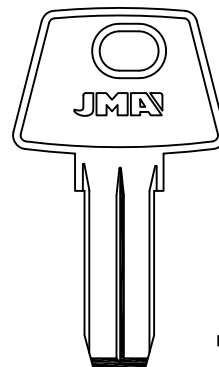

**AGA-29**

CASAS

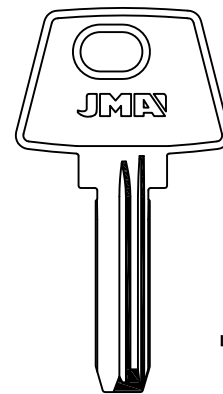

**AGA-38**

**AGA-42**

**AGA-48**





## AGA

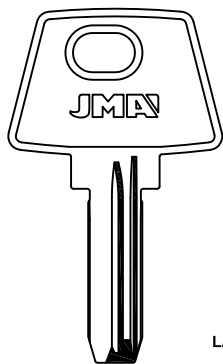

LAT.

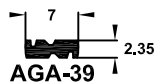

AGA-43 AGA-49

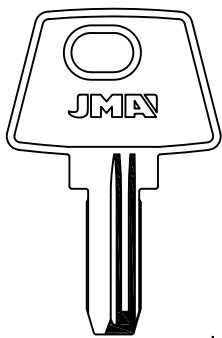

LAT.



AGA-50

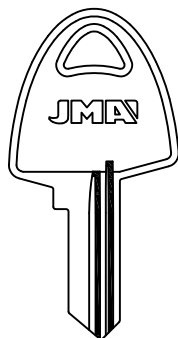

111  
AGA-51

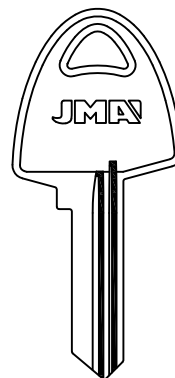

121  
AGA-52

## PARA-FOR:

AGA (E)

AGB (I)

AGC (P)

AGE (J)

## AGB

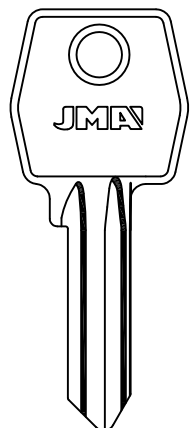

AGB-1 AGB-1D

OIAUS

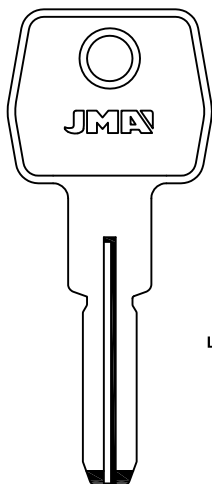

LAT.

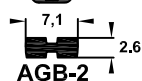

AGB-2

SCUDO

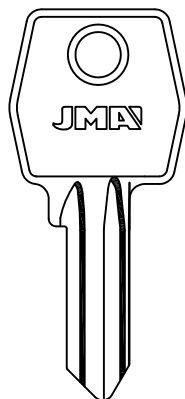

AGB-3 AGB-3D

OIAUS

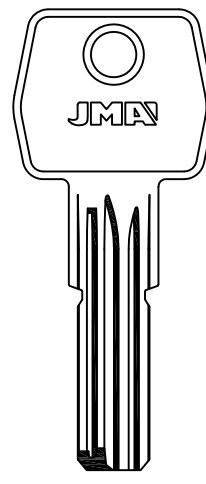

LAT.

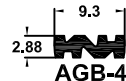

AGB-4

SCUDO 5000

## AGB

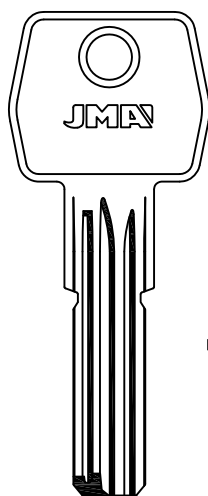

LAT.



AGB-5

SCUDO 5000

## AGC

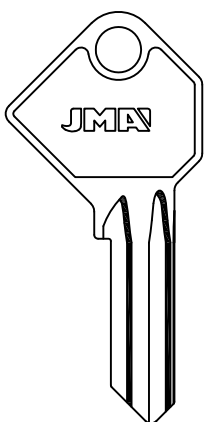

AGD-1

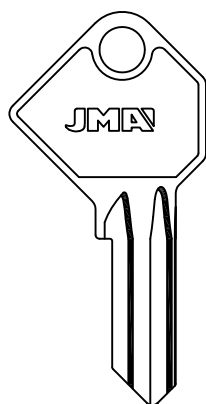

AGD-2

## AGE

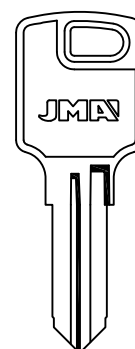

AGE-11



**PARA-FOR:**

- AGE (J)
- AGUIA (P)
- AGUT (E)
- AHRAM (ET)
- AIZPUTE (RUS)
- ALDRIDGE (GB)
- ALE (E)

|          | AGE |       | AGUIA |         |  |          |  |
|----------|-----|-------|-------|---------|--|----------|--|
|          |     |       |       |         |  |          |  |
|          |     |       |       |         |  |          |  |
|          |     |       |       |         |  |          |  |
|          |     |       |       |         |  |          |  |
|          |     |       |       |         |  |          |  |
|          |     |       |       |         |  |          |  |
| AGUT     |     | AHRAM |       | AIZPUTE |  | ALDRIDGE |  |
|          |     |       |       |         |  |          |  |
|          |     |       |       |         |  |          |  |
|          |     |       |       |         |  |          |  |
| ALDRIDGE |     |       |       | ALE     |  |          |  |
|          |     |       |       |         |  |          |  |
|          |     |       |       |         |  |          |  |



# ALFA

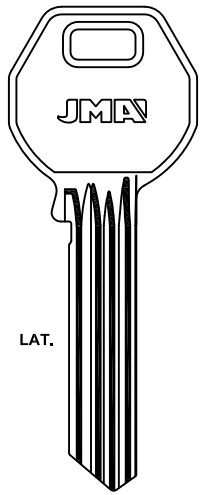

ALF-8

ALF-8D

ALF-15

ALF-22D

ALF-29

ALF-36

ALF-7

ALF-14D

ALF-21

ALF-28

ALF-35

ALF-6

ALF-13D

ALF-20

ALF-27

ALF-34

ALF-5

ALF-12D

ALF-19

ALF-26

ALF-33

ALF-4

ALF-11D

ALF-18

ALF-25

ALF-32D

ALF-3

ALF-10

ALF-10D

ALF-17

ALF-24

ALF-31

ALF-1

ALF-2

ALF-9

ALF-16

ALF-23

ALF-30

GE GE

# PARA-FOR:

ALFA (S)

ALIANCA (BR)

ALPHA (J)

ALTAY (RUS)

AMARU (P)

## ALIANCA

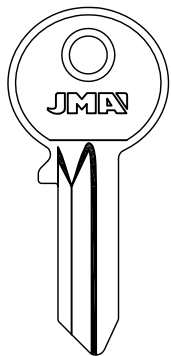

ALC-1D

## ALPHA

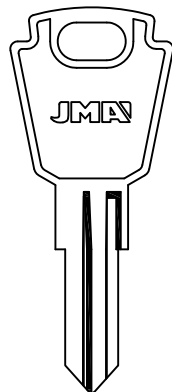

S...301-600

ALP-1I

ALP-1D

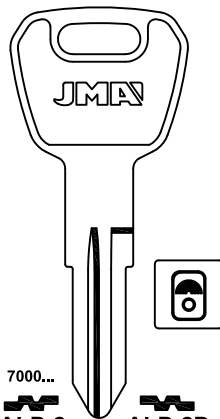

7000...

ALP-2

ALP-2D

JD-LINCE-MONACOR  
SANY-VISONIC

S...301-600

ALP-6

ALP-6D

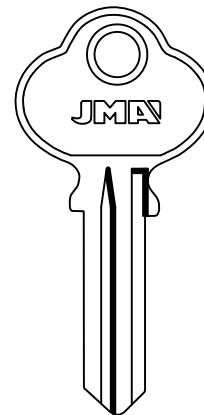

ALP-3

FEB

FEB

## ALPHA

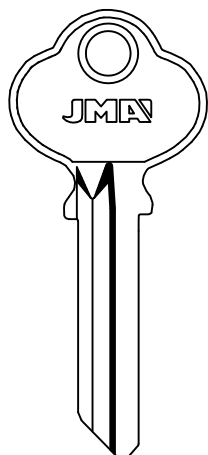

ALP-4D

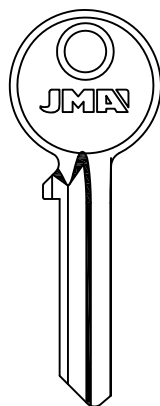

ALP-5D

## ALTAY

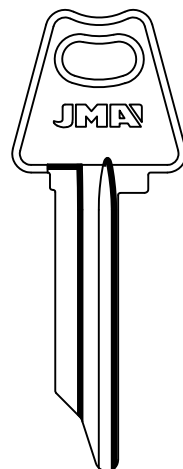

ATA-1

ATA-1D

## AMARU

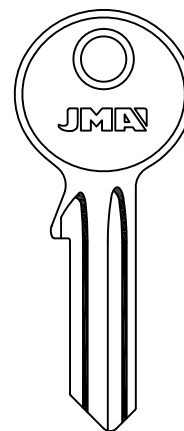

AMA-1

AMA-1D

AL









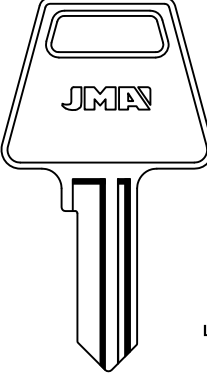
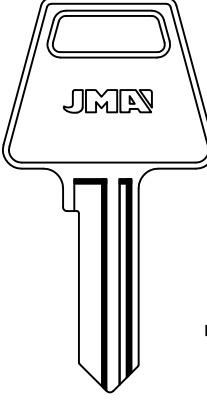
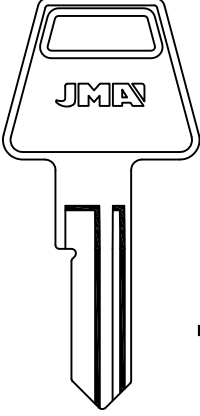
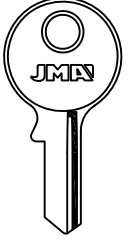

**PARA-FOR:**



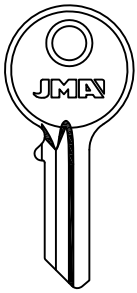
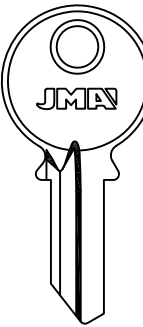
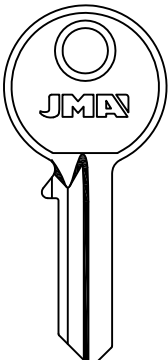
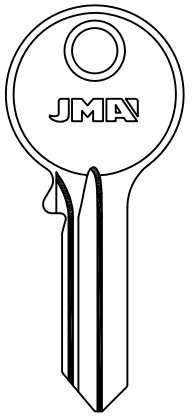

AMERICAN LOCK  
(USA)

AMIG (E)

ANCHOR (S)

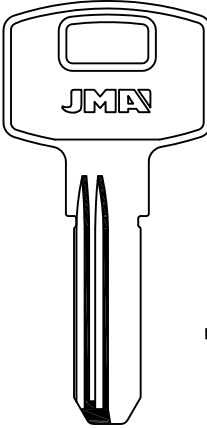
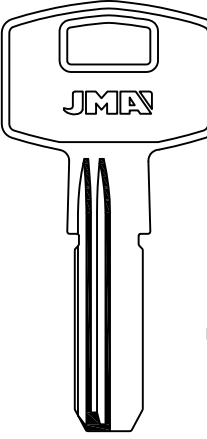
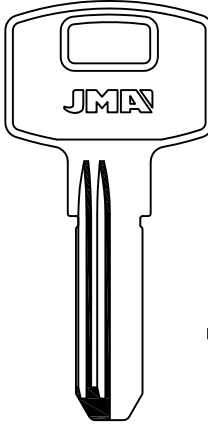
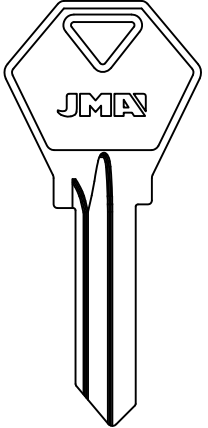
| AMERICAN LOCK  |  |  | AMIG  |
|--|--|--|---|
|           |           |            |                          |
| LAT.   | LAT.   | LAT.   |   |
| <br>AME-1 | <br>AME-2 | <br>AME-4 | 1-15 / 1-20<br><br>AMG-1 |

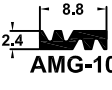
| AMIG  |   |   |   |
|---|---|---|---|
|                     |                     |                     |                     |
| 1-25<br><br>AMG-2D | 1-30<br><br>AMG-3D | 1-40<br><br>AMG-4D | 1-50<br><br>AMG-5D |

| AMIG  |  |   | ANCHOR   |
|---|--|---|--|
|                    |                           |                     |                         |
| LAT.  | LAT.   | LAT.  |  |
| <br>AMG-8D<br>5000 | <br>AMG-9D<br>2500<br>GMB | <br>AMG-10D<br>4900 | <br>ANC-1D<br>ANKERSLOT |



## ANCHOR

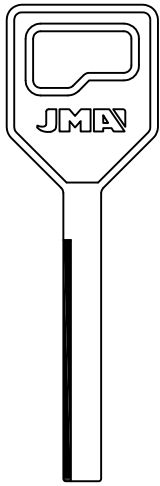

ALP.



ANC-2

## ANKER

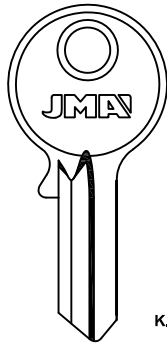

K...111-888  
....  
K...  
1011-7077  
E...  
F...  
B...  
1-2-3-4-5-6-7



ANK-1

ANCHOR-LITTO-ODA

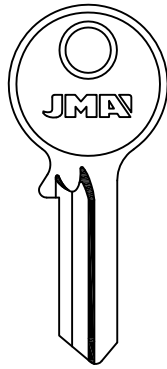

ANK-2

ODA

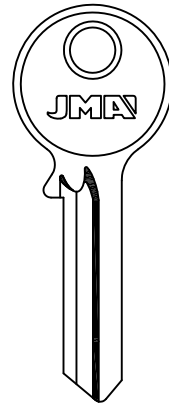

ANK-3

ODA

## PARA-FOR:

ANCHOR (S)

ANKER (NL)

ANTAR (F)

APEX (RUS)

## ANKER

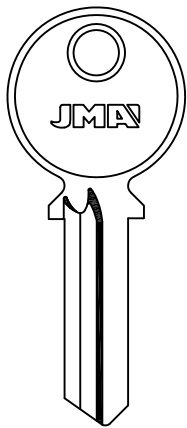

ANK-4

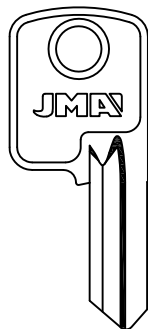

K...111-888  
....  
K...  
1011-7077  
E...  
F...  
B...  
1-2-3-4-5-6-7



ANK-6

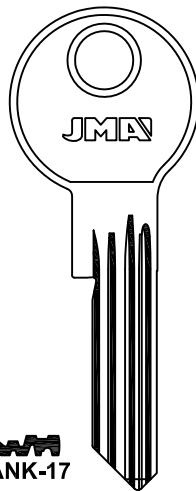

ANK-17



ANK-65

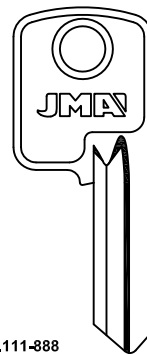

K...111-888  
....  
K...  
1011-7077  
E...  
F...  
B...  
1-2-3-4-5-6-7



ANK-47D

## ANTAR

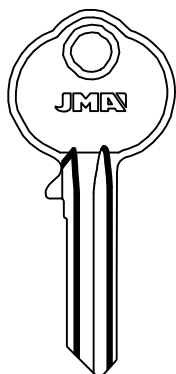

ANA-1



ANA-1D

VEGA

## APEX

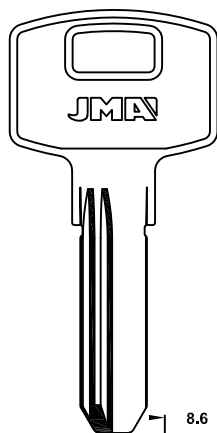

LAT.



AP-1D



AP-3D

AMIG-BYP-C.V.C.

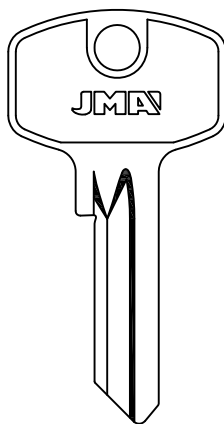

AP-2D

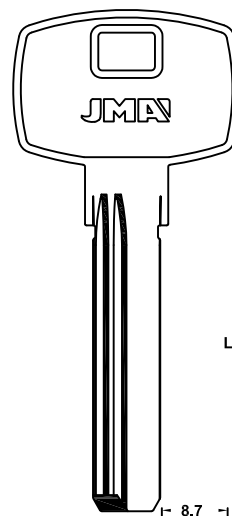

LAT.

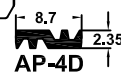

AP-4D

FTH

**JMA**<sup>®</sup>

Copyright by Alejandro Altuna S.A. 2014



ATENCIÓN: Concerniente a las marcas y denominaciones comerciales ver nota en índice.

ATTENTION: Concerning the marks and commercial denominations see note in index.

ATTENTION: Concernant les marques et dénominations commerciales voir la note dans l'index.

ACHTUNG: Beziehen auf die marke und handelsname sehen sie die notiz im index.

**PARA-FOR:**

- APEX (RUS)
- ARCU (E)
- AREL (GB)
- ARFE (E)
- ARMSTRONG (USA)
- AROUCA (BR)
- ARREGUI (E)
- ARROW (USA)

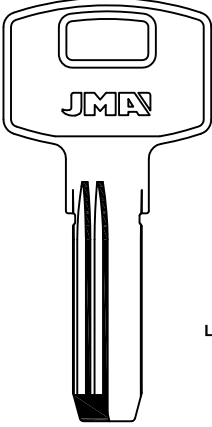
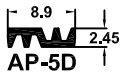
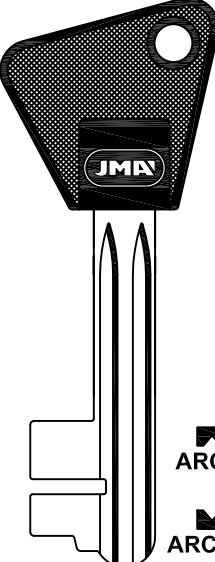
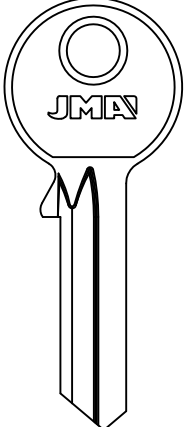
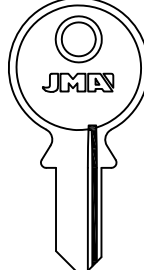
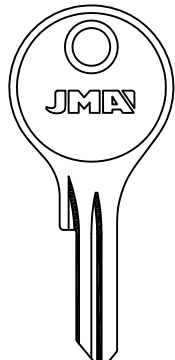
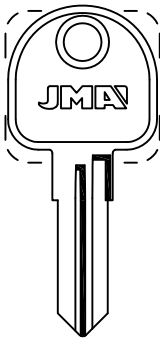
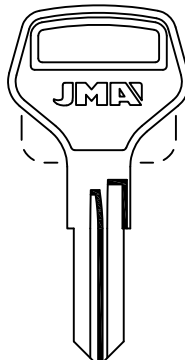
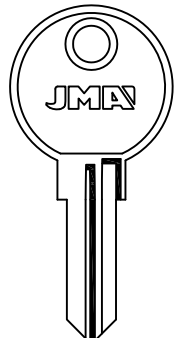
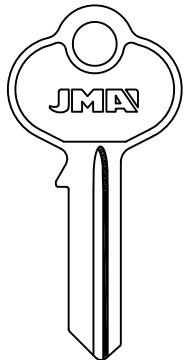
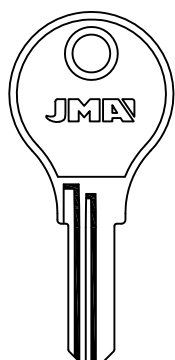
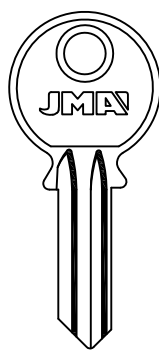
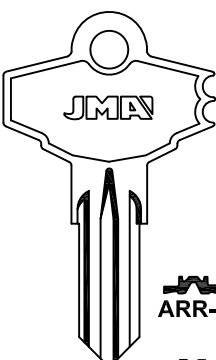
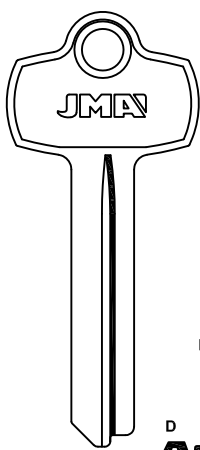
| APEX   | ARCU   | AREL  | ARFE  |  |
|--|--|---|---|--|
|  <p>LAT.</p>  <p>AP-5D</p> |  <p>ALP.</p> <p>A<br/>ARC-17.P</p> <p>B<br/>ARC-17D.P</p> |  <p>ARE-1D</p>  |  <p>ARFE-1I    ARFE-1D</p>                             |  |
| ARFE   | ARMSTRONG  |   |   | AROUCA   |
|  <p>ARFE-3D</p>  |  <p>ARN-1</p>  |  <p>ARN-2</p>  |  <p>ARN-2D    ARN-3    ARN-3D</p> <p>ABUS</p>         |  <p>ARO-1D</p> |
| ARREGUI  |  | ARROW   |   |  |
|  <p>AR-1D</p>   |  <p>AR-4IP    AR-4DP</p> <p>INDAUX</p>                  |  <p>ARR-1</p> <p>ARR-2</p> <p>ARR-3</p> <p>ARR-8</p> <p>DOMINION LOCK-FORT-LG</p> |  <p>LAT.</p> <p>D<br/>ARR-7D</p> <p>C<br/>ARR-9D</p> |  |



**ARSENEVSK**

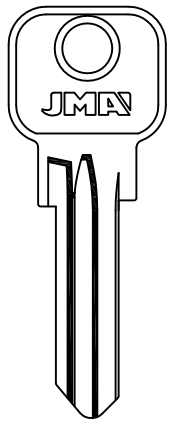

**ASHICO**

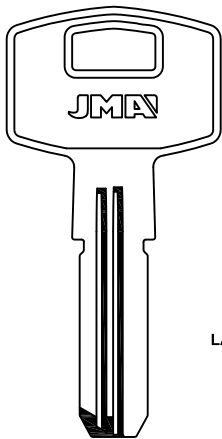

LAT.

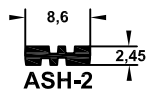

**ASIA**

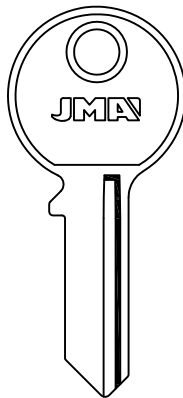

CINA

**ASPA**

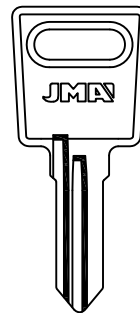

**PARA-FOR:**

- ARSENEVSK (RUS)
- ASHICO (TJ)
- ASIA (RC)
- ASPA (NL)
- ASSA (S)

**ASSA**

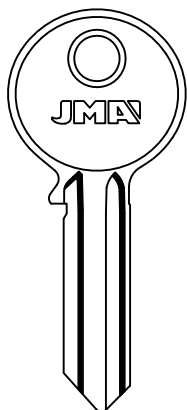

ABC  
0 AL 9

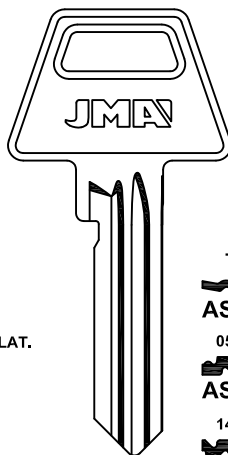

\* LAT.



**ASSA**

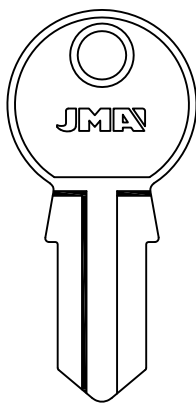
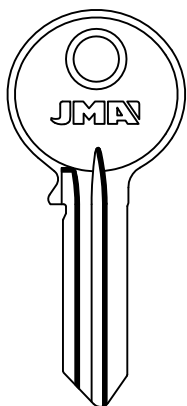

LAT.

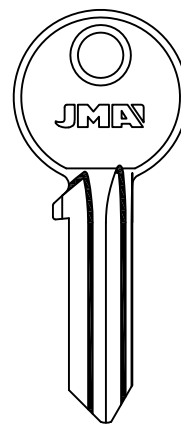

TEKA



**PARA-FOR:**

ASSA (S)

**ASSA**

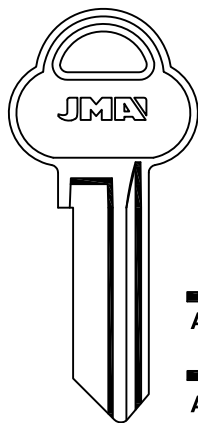

28,4 mm.

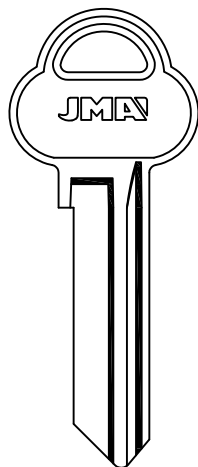

34,5 mm.



**ASSA**

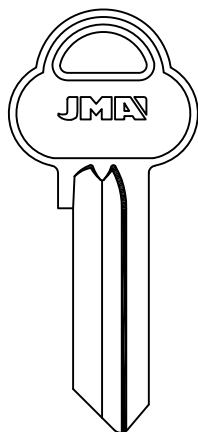

29,7 mm.



**ASSA**

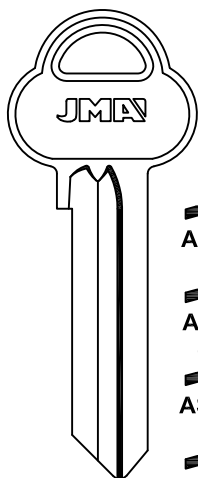

35,7 mm.





# ASSA

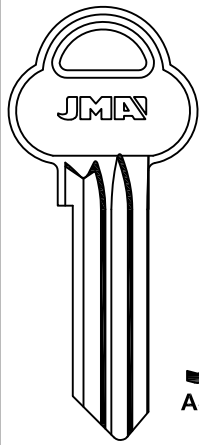

31 mm.

560MG  
AS-MG5  
560KE  
AS-KE5  
560ME  
AS-ME5

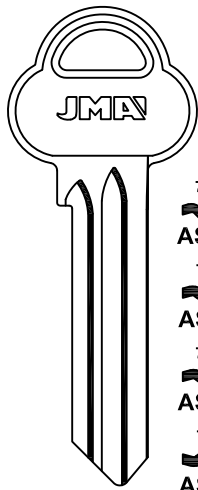

37 mm.

760DD  
AS-DD7  
760KA  
AS-KA7  
760KD  
AS-KD7  
760KF  
AS-KF7  
760LA  
AS-LA7  
760HH  
AS-HH7  
760KE  
AS-KE7  
760KG  
AS-KG7  
760LF  
AS-LF7  
760LE  
AS-LE7

760LD  
AS-LD7

760LG  
AS-LG7

760MA  
AS-MA7

760ME  
AS-ME7

760MD  
AS-MD7

760MG  
AS-MG7

760MF  
AS-MF7

760PF  
AS-PF7

760PG  
AS-PG7

760PA  
AS-PA7

760PB  
AS-PB7

760PH  
AS-PH7

760PR  
AS-PR7

760VV  
AS-VV7

760UU  
AS-UU7

760PN  
AS-PN7

760PT  
AS-PT7

760TT  
AS-TT7

760WW  
AS-WW7

760XX  
AS-XX7

# PARA-FOR:

- ASSA (S)
- AUMON (E)
- AVANGARD (RUS)
- AZBE (E)

## AUMON

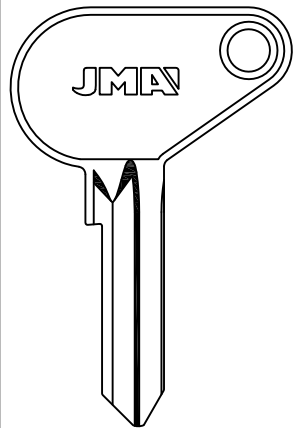

AUM-2D

## AVANGARD

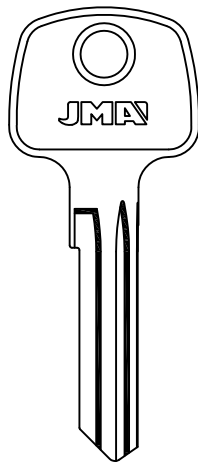

AV-1 AV-1D

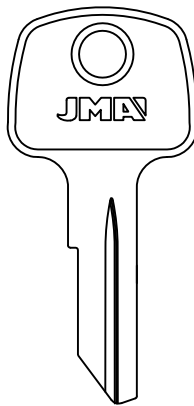

AV-2D

## AZBE

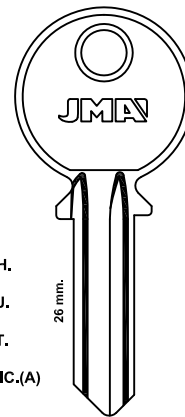

FSH.  
ALU.  
LAT.  
\* MTIC.(A)

26 mm.

AZ-1I AZ-1D \*

ZAIN

## AZBE

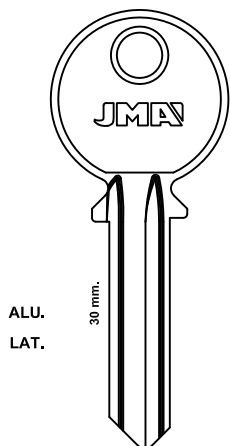

ALU.  
LAT.

30 mm.

AZ-2I AZ-2D

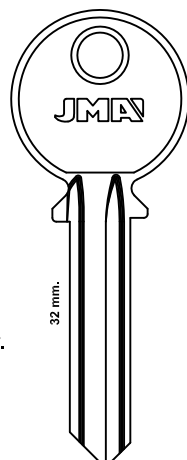

LAT.

32 mm.

AZ-3I AZ-3D

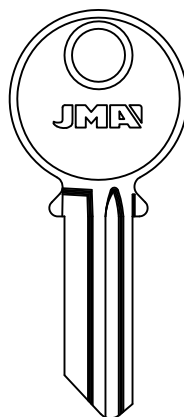

AZ-4

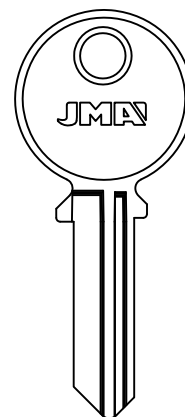

AZ-6



**PARA-FOR:**

AZBE (E)

AZKOYEN (E)

B+D (GB)

**AZBE**

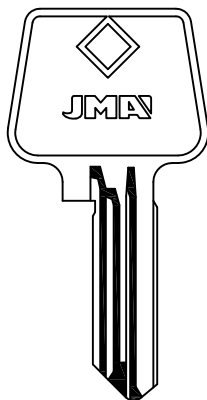

ALP.



AZ-7

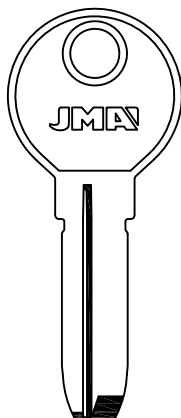

ALP.

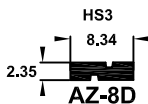

AZ-8D

IFAM

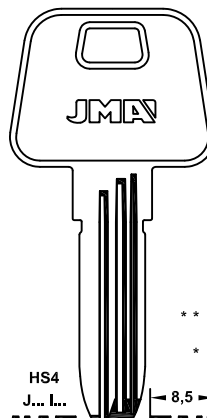

\*\* ALP.

\* LAT.

HS4

J... I...

AZ-9

HS2

2... 3...

AZ-12

\*\*

AZ-12

HS7

AZ-29

\*

AZ-29

CAVERS-CENTURION-ZAIN

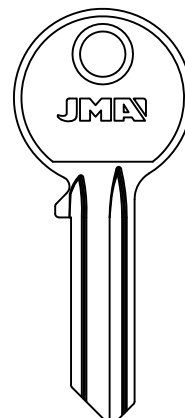

AZ-10

**AZBE**

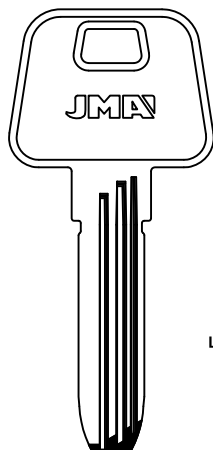

LAT.



AZ-14

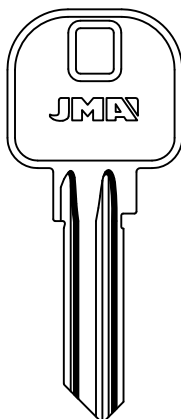

AZ-17



AZ-17D

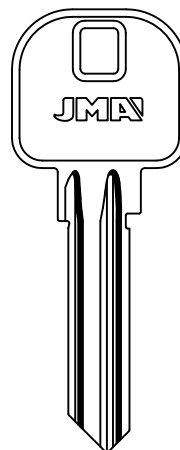

AZ-18



AZ-18D

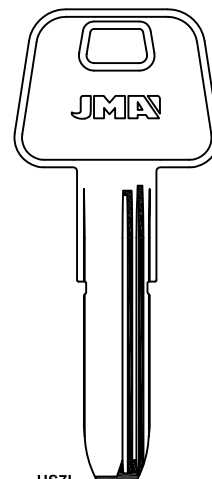

LAT.



AZ-32

**AZBE**

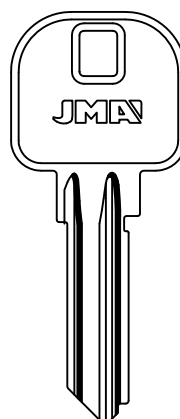

AZ-37



AZ-37D

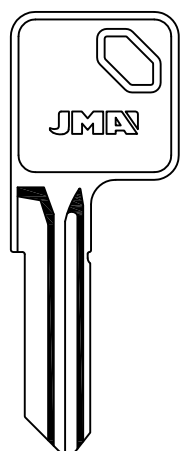

LAT.



SCO-1

SCHLAGE-SCOVILL

**AZKOYEN**

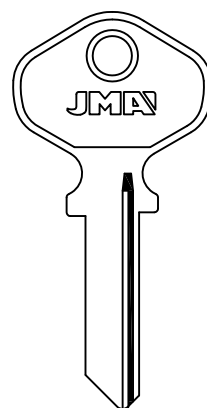

AZKO-11

AGA

**B+D**

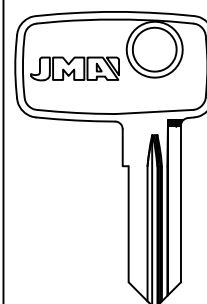

BD-1

ROLL A DOOR



**BAB**

**PARA-FOR:**

BAB (D)

BAGEM (E)

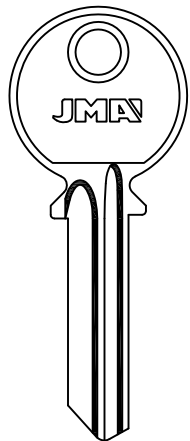

BAB-11

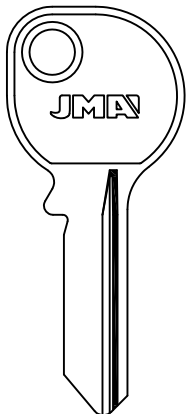

BAB-21

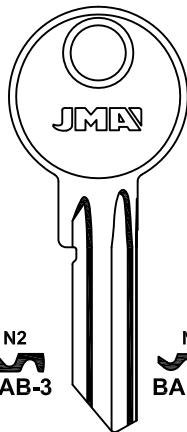

N2  
BAB-3

N1  
BAB-3D

BAB-12D

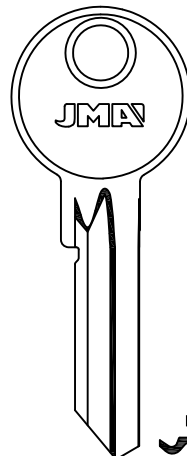

SN2  
BAB-5

N1  
BAB-4D

SN1  
BAB-5D

**BAB**

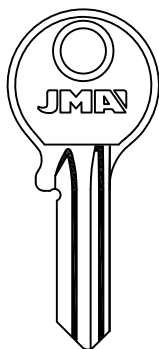

BAB-6

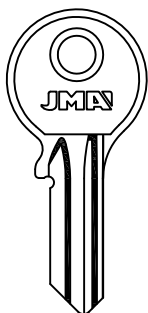

BAB-7

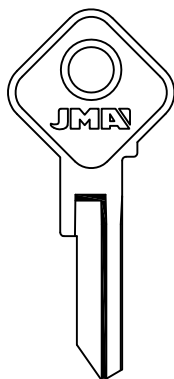

BAB-8D

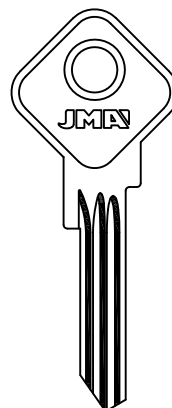

BAB-9D

**BAB**

**BAGEM**

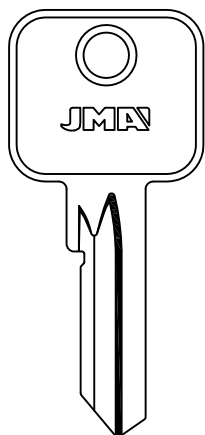

BAB-14D

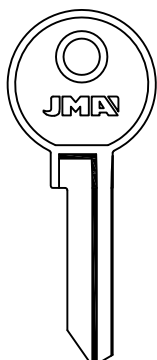

LAT.

BAB-17D

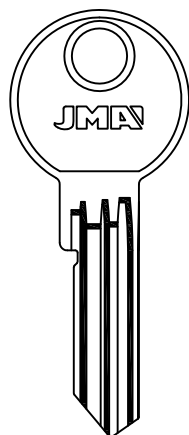

BAB-19

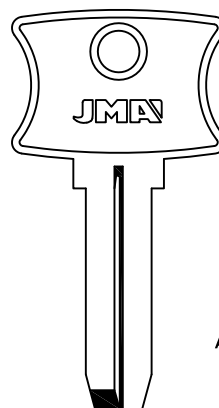



ALP.

BAG-1

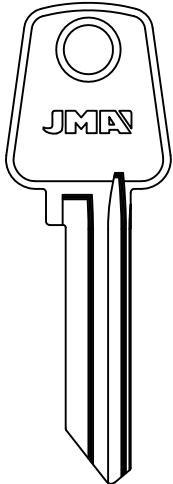
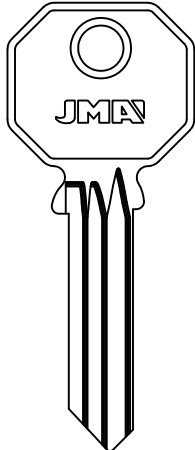
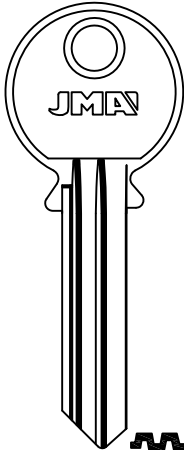
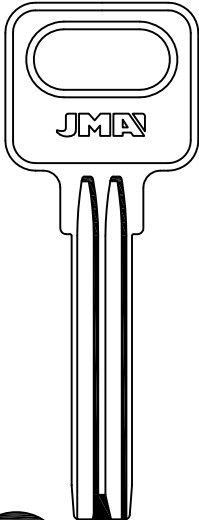

**PARA-FOR:**

- BALTIKA (RUS)
- BANHAM (GB)
- BAODEAN (TJ)
- BARCZ (PL)
- BARIER (RUS)
- BASCO (USA)
- BASI (D)
- BASTA (IRL)

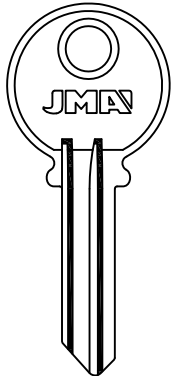
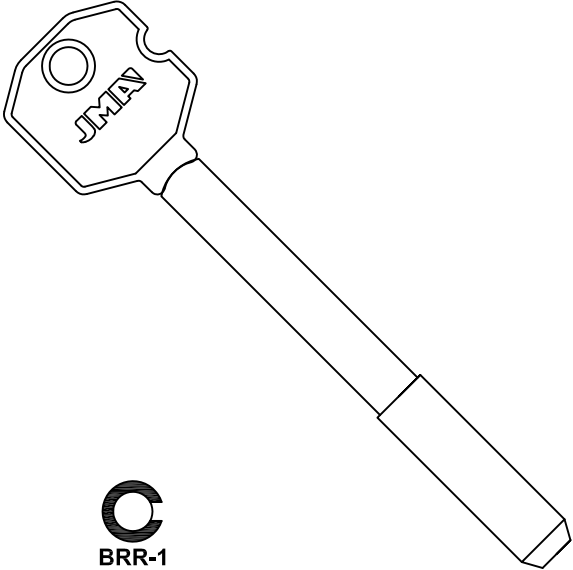
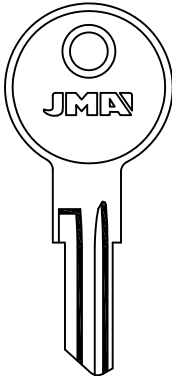
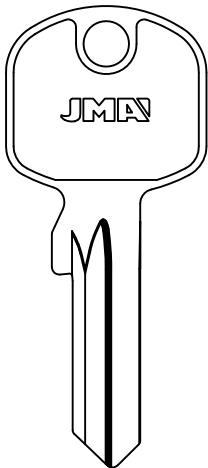
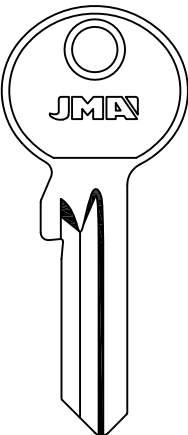
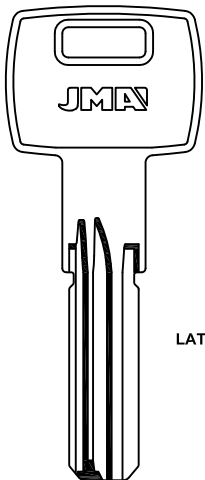
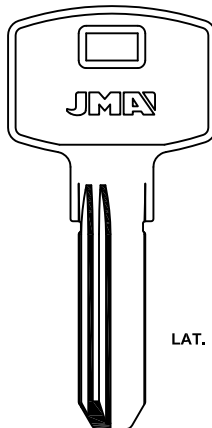
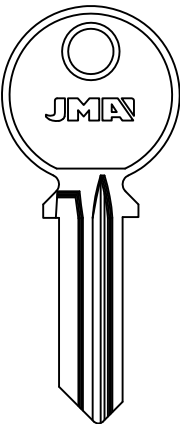
| BALTIKA  | BANHAM   |   | BAODEAN   |
|--|--|---|---|
|  <p><b>BLT-1</b></p>                      |  <p><b>BAN-1I</b></p>   |  <p><b>BAN-1D</b></p>                     |  <p><b>BDA-1</b></p> <p>LAT.</p>   |
|  |  |  <p><b>BAN-2D</b></p>                    |   |
|  |  |  <p><b>BAN-3D</b></p>                    |   |
|  |  |   | <p>BTV</p>  |
| BARCZ  | BARIER   |   | BASCO   |
|  <p><b>BCZ-1</b></p> <p><b>BCZ-2</b></p> |  <p><b>BRR-1</b></p>  |   |  <p><b>BAS-4</b></p> <p>AMERICAN M.-B&amp;S-CHICAGO C.<br/>ELMO-HERSEE E.-ILLINOIS-YALE</p> |
|  |  |   |   |
| BASI   |  |   | BASTA   |
|  <p><b>BAI-1D</b></p> <p>1 AL 9</p>     |  <p><b>BAI-5D</b></p> |  <p><b>BAI-8D</b></p> <p>GEVY-SATURN</p> |  <p><b>BAI-9D</b></p> <p>TOVER</p> <p>CX<br/>8,6<br/>2,5</p>                               |
|  |  |   |  <p><b>BAST-1I</b></p>   |
|  |  |   |   |



| BASTA       |             |               | BATU        |
|-------------|-------------|---------------|-------------|
|             |             |               |             |
| <br>BAST-2D | <br>BAST-3D | <br>BAST-4D.P | <br>BATU-11 |
| EURO LOCKS  |             |               |             |

**PARA-FOR:**

- BASTA (IRL)
- BATU (E)
- BEST (USA)
- BETA (I)
- BEY (TR)
- BIBERING (D)

| BEST   |  | BETA     |  |
|--------|--|----------|--|
|        | <p>Q<br/>BES-12D</p> <p>R<br/>BES-13D</p> <p>L<br/>BES-10D</p> <p>M<br/>BES-11D</p> <p>J<br/>BES-8D</p> <p>K<br/>BES-9D</p> <p>TB<br/>BES-17D</p> <p>G<br/>BES-6D</p> <p>H<br/>BES-7D</p> <p>F<br/>BES-16D</p> <p>DD<br/>BES-4D</p> <p>E<br/>BES-5D</p> <p>FM<br/>BES-15D</p> <p>A<br/>BES-1D</p> <p>C<br/>BES-2D</p> <p>D<br/>BES-3D</p> <p>B<br/>BES-14D</p> |          |  |
| LAT.   |  | LAT.     |  |
| FALCON |  | <br>BE-1 | <p>....1-2-3-4-5-6</p> <p><br/>BE-4I</p> <p><br/>BE-4D</p> |

| BETA   | BEY                                     |  | BIBERING       |
|--|---|--|----------------|
|  |   |  |                |
| <p>....1-2-3-4-5-6</p> <p><br/>BE-5I</p> <p><br/>BE-5D</p> | LAT.                                    | LAT.                                     |                |
| PICARD   | <p>9</p> <p><br/>BEY-1D</p> <p>2.85</p> | <p>8.9</p> <p><br/>BEY-2D</p> <p>1.8</p> | <br>BI-1D      |
|  |   |  | TAS-TÜRSCHLOSS |



**PARA-FOR:**











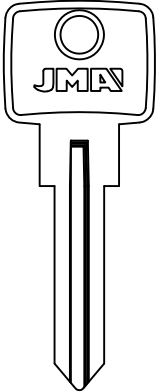
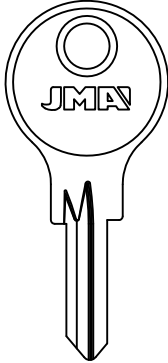
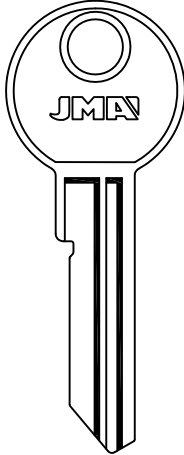
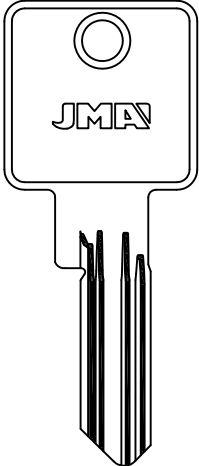



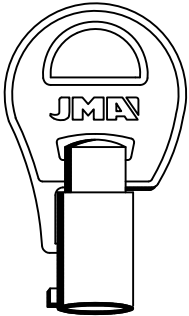
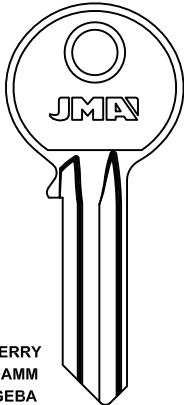
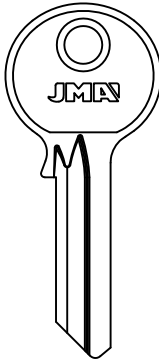
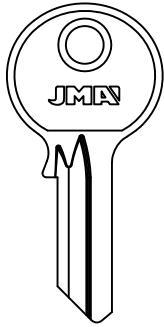





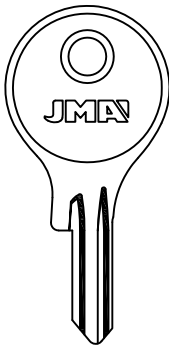
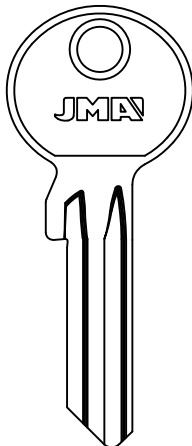
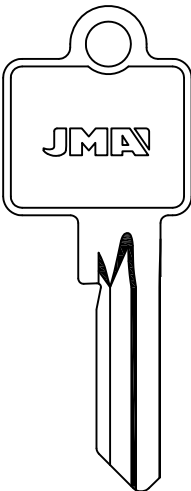



BIBERING (D)

BIELLE (I)

BIFFAR (D)

BILMA (E)

BKS (E)

| BIBERING  |  | BIELLE   |  | BIFFAR  |   |
|---|--|--|--|---|---|
|              |             |            |               |   |   |
| <br>BI-2     | <br>BI-3D   | <br>BIE-1 | <br>BIF-1     |   |   |
|   |  | FASEM-OMIV-P.C.  |  | BFA3<br>FICHET-TOK  |   |
| BILMA   |  |  | BKS  |   |   |
|             |            |          |              |   |   |
| LAT.  | BERRY<br>DAMM<br>GEB<br>HOHRMANN<br>PZ<br>YALE   | ALU.   |  |   |   |
| <br>BIL-1T | <br>BK-1I | <br>BK-1D | <br>BK-2D   | <br>BK-3D    | R<br>101-105  |
|   |  |  | YALE   | YALE-WECO   |   |
| BKS   |  |  |  |   |   |
|            |           |          | <br>BK-21/1 | <br>BK-21/2  | <br>BK-21/7  |
| <br>BK-4   | <br>BK-4D | <br>BK-6I | <br>BK-21/9 | <br>BK-21/14 | <br>BK-21/17 |
| <br>BK-5I  | <br>BK-5D | <br>BK-6D | <br>BK-7D   | <br>BK-21/19 |   |
| METEOR-YALE   |  |  |  |   |   |



## BKS

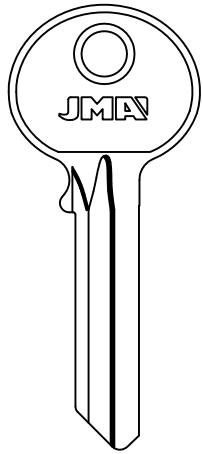

NA  
BK-8D

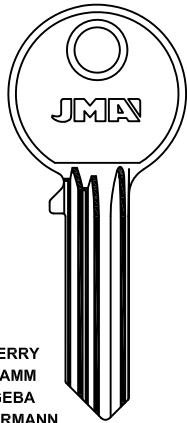

BERRY  
DAMM  
GEBÄ  
HOHRMANN  
PZ  
YALE

BK-9  
SERIE O

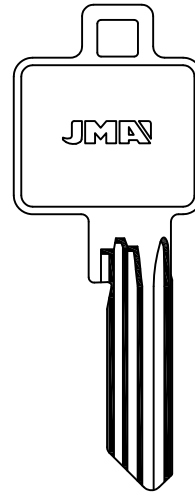

BK-14  
PZ-YALE

PARA-FOR:

BKS (D)

## BKS

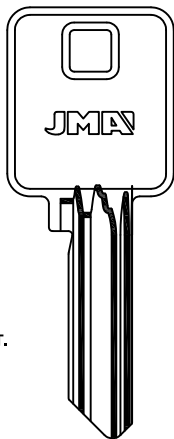

\* LAT.

|           |            |            |
|-----------|------------|------------|
| * BK-16/7 | * BK-16/17 |            |
| * BK-16/5 | * BK-16/16 | BK-16/30   |
| * BK-16/4 | * BK-16/15 | * BK-16/23 |
| * BK-16/3 | * BK-16/14 | * BK-16/21 |
| * BK-16/2 | * BK-16/13 | * BK-16/20 |
| * BK-16/1 | * BK-16/10 | * BK-16/19 |
| * BK-16/0 | * BK-16/9  | * BK-16/18 |

SERIE 2000

## BKS

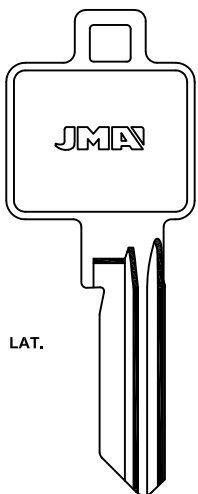

LAT.

|           |            |           |         |         |
|-----------|------------|-----------|---------|---------|
| BK-17/7PZ |            |           | BK-17/7 |         |
| BK-17/6PZ |            |           | BK-17/6 |         |
| BK-17/5PZ |            |           | BK-17/5 |         |
| BK-17/4PZ | BK-17D/4PZ |           | BK-17/4 |         |
|           | BK-17D/3PZ |           | BK-17/3 |         |
| BK-17/2PZ | BK-17D/2PZ | BK-17/9PZ | BK-17/2 | BK-17/9 |
| BK-17/1PZ | BK-17D/1PZ | BK-17/8PZ | BK-17/1 | BK-17/8 |

PZ-YALE

SERIE O

**JMA**®

Copyright by Alejandro Altuna S.A. 2014



ATENCIÓN: Concerniente a las marcas y denominaciones comerciales ver nota en índice.  
 ATTENTION: Concerning the marks and commercial denominations see note in index.  
 ATTENTION: Concernant les marques et dénominations commerciales voir la note dans l'index.  
 ACHTUNG: Beziehen auf die marke und handelsname sehen sie die notiz im index.

**PARA-FOR:**

- BKS (D)
- BMB (D)
- BODA (SF)

**BKS**

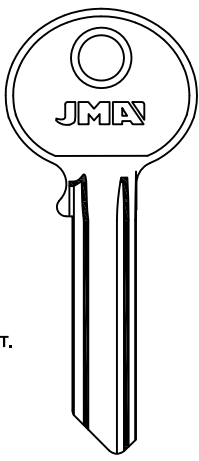

LAT.

|               |                 |                 |                 |                 |
|---------------|-----------------|-----------------|-----------------|-----------------|
| B7<br>BK-18/7 | B15<br>BK-18/15 | B23<br>BK-18/23 | B30<br>BK-18/30 |                 |
| B6<br>BK-18/6 | B14<br>BK-18/14 | B22<br>BK-18/22 | B29<br>BK-18/29 |                 |
| B5<br>BK-18/5 | B13<br>BK-18/13 | B21<br>BK-18/21 | B28<br>BK-18/28 | B35<br>BK-18/35 |
| B4<br>BK-18/4 | B12<br>BK-18/12 | B20<br>BK-18/20 | B27<br>BK-18/27 | B34<br>BK-18/34 |
| B3<br>BK-18/3 | B11<br>BK-18/11 | B18<br>BK-18/18 | B26<br>BK-18/26 | B33<br>BK-18/33 |
| B2<br>BK-18/2 | B10<br>BK-18/10 | B17<br>BK-18/17 | B25<br>BK-18/25 | B32<br>BK-18/32 |
| B1<br>BK-18/1 | B9<br>BK-18/9   | B16<br>BK-18/16 | B24<br>BK-18/24 | B31<br>BK-18/31 |

SERIE 1000



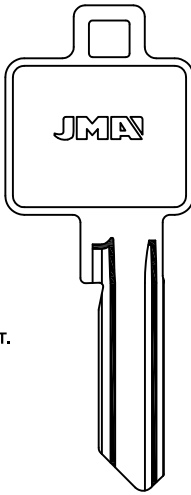



**BKS**

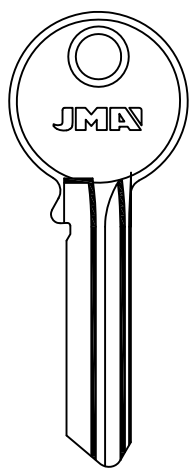

LAT.

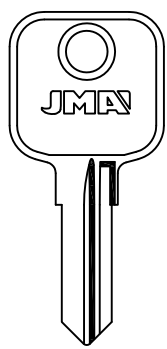
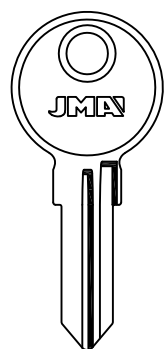
|               |                 |                 |                 |
|---------------|-----------------|-----------------|-----------------|
| B8<br>BK-19/8 | B16<br>BK-19/16 | B27<br>BK-19/27 |                 |
| B7<br>BK-19/7 | B15<br>BK-19/15 | B26<br>BK-19/26 |                 |
| B6<br>BK-19/6 | B14<br>BK-19/14 | B25<br>BK-19/25 |                 |
| B5<br>BK-19/5 | B13<br>BK-19/13 | B23<br>BK-19/23 |                 |
| B4<br>BK-19/4 | B12<br>BK-19/12 | B21<br>BK-19/21 |                 |
| B2<br>BK-19/2 | B11<br>BK-19/11 | B20<br>BK-19/20 | B32<br>BK-19/32 |
| B1<br>BK-19/1 | B10<br>BK-19/10 | B19<br>BK-19/19 | B31<br>BK-19/31 |

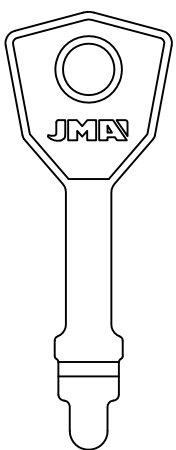
SERIE 1000

| BKS  | BMB   | BODA   |
|--|---|--|
| <br> BK-20 | <br><br>LAT.<br>A<br> BMB-1<br>M<br> BMB-3D | <br> BOD-1 |





## BOMORO

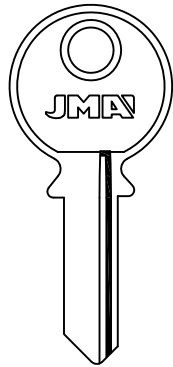
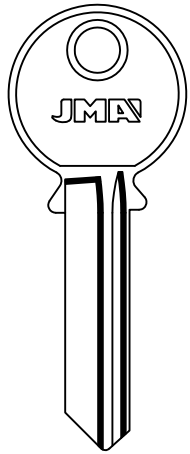

LAPORTE-PRESTA

## BÖRKEY

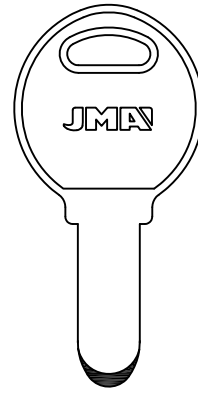
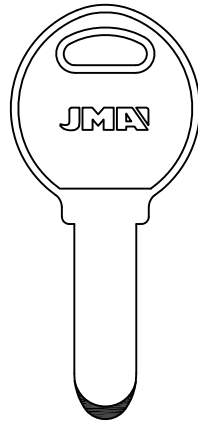

LAT.

LAT.

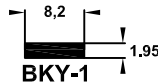

PHILLIPS-YALTRES



PHILLIPS-YALTRES

## BOULTON & P.

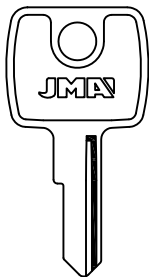

RST

## BRABANTIA

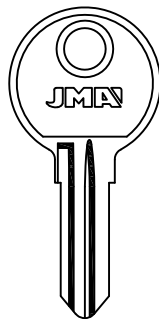

BRA-2

## BRAS

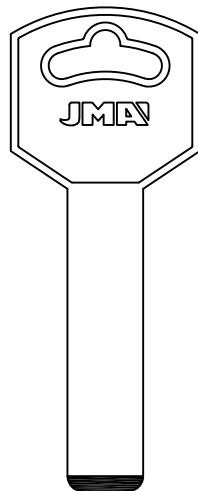

ALP.



BRAS-1

## BRASIL

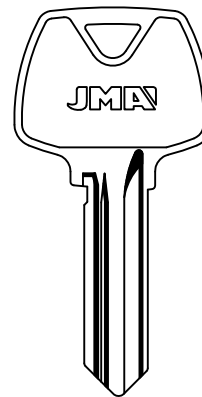

BRS-1

## BRICARD

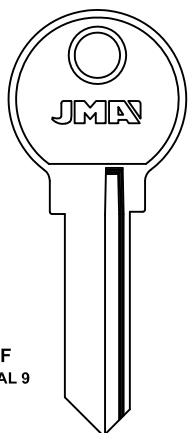

F  
0 AL 9

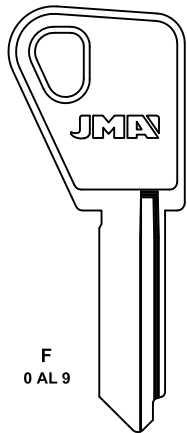

F  
0 AL 9

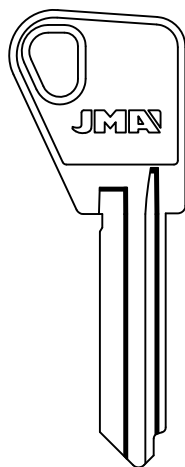

F  
0 AL 9



STREMLER

## PARA-FOR:

BOMORO (D)

BÖRKEY (D)

BOULTON & PAUL  
(GB)

BRABANTIA (E)

BRAS (E)

BRASIL (BR)

BRICARD (F)

**JMA**<sup>®</sup>

Copyright by Alejandro Altuna S.A. 2014



ATENCIÓN: Concerniente a las marcas y denominaciones comerciales ver nota en índice.

ATTENTION: Concerning the marks and commercial denominations see note in index.

ATTENTION: Concernant les marques et dénominations commerciales voir la note dans l'index.

ACHTUNG: Beziehen auf die marke und handelsname sehen sie die notiz im index.

**PARA-FOR:**

BRICARD (F)

BRUMME (D)

BSS (SCG)

**BRICARD**

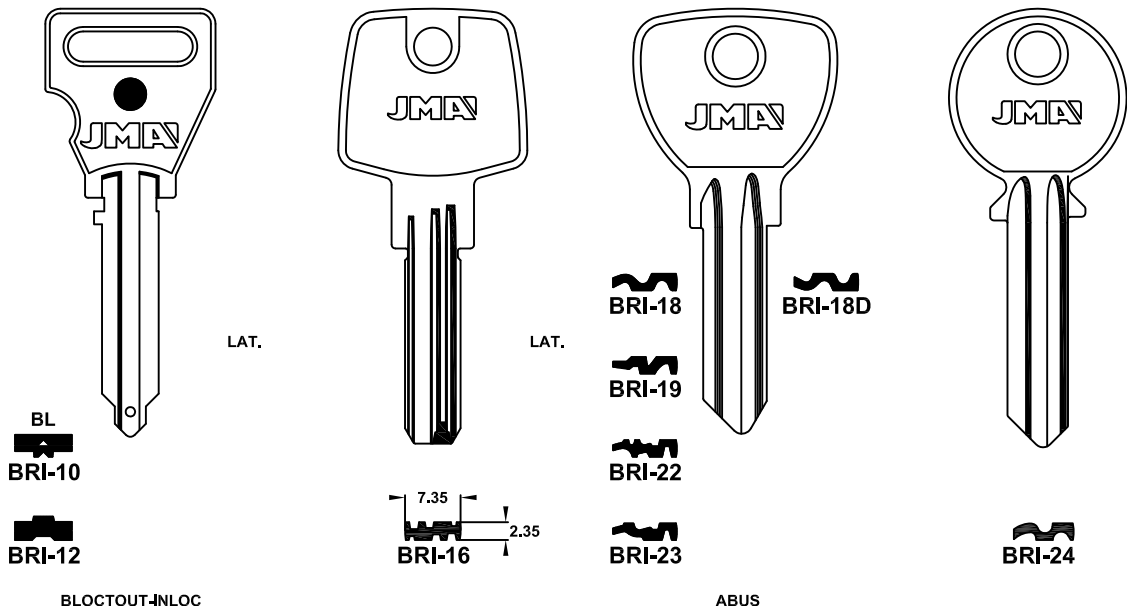

**BRICARD**

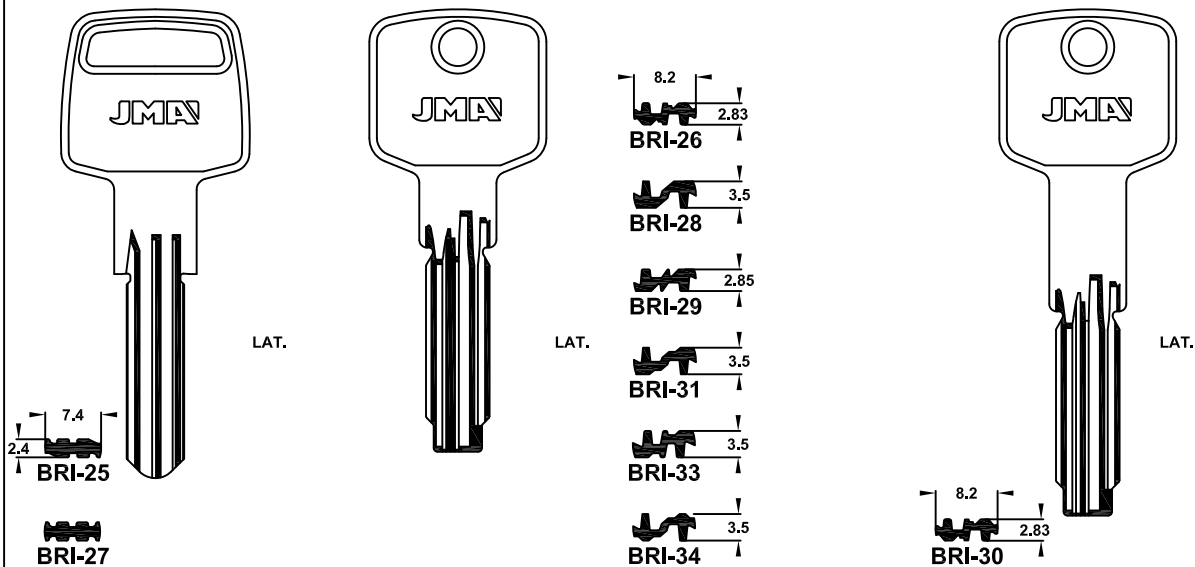

**BRICARD**

**BRUMME**

**BSS**

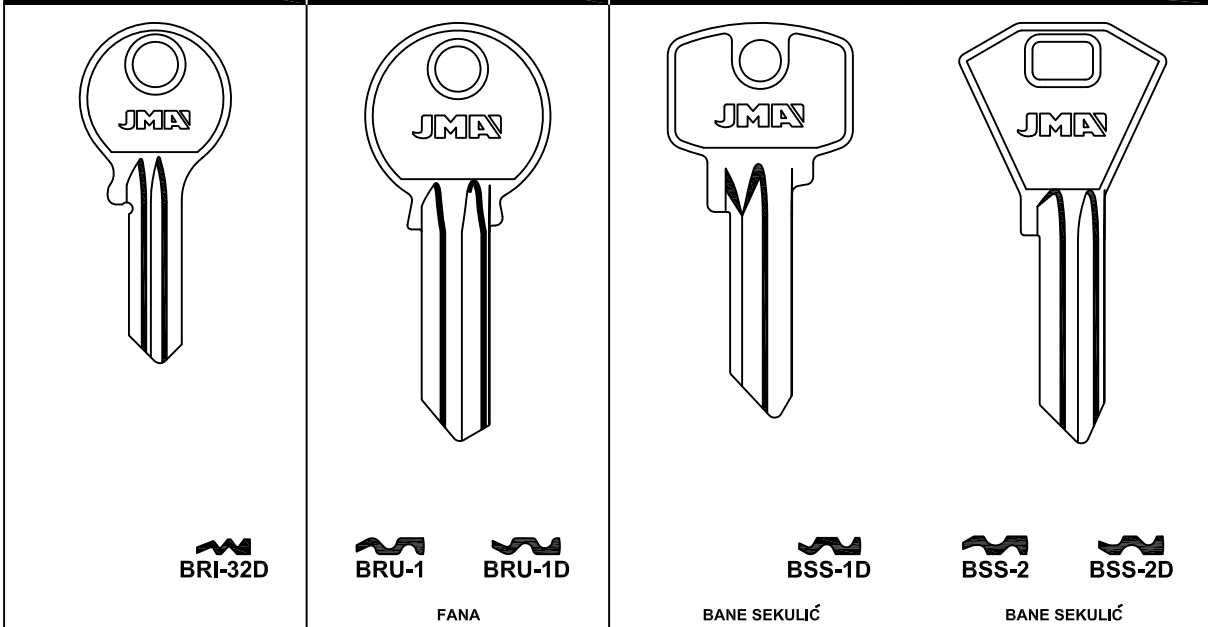

## BSS

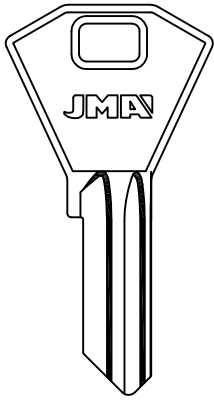

BSS-3

BANE SEKULIĆ

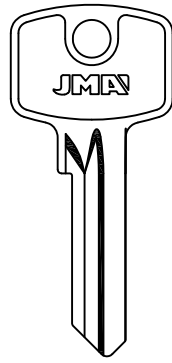

BSS-4D

BANE SEKULIĆ

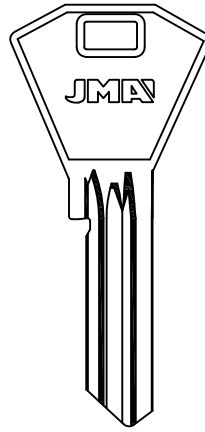

BSS-5D

BANE SEKULIĆ-GE GE

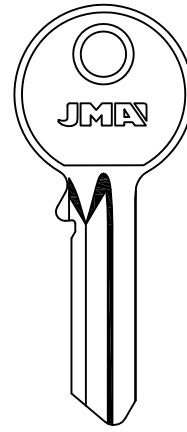

BSS-6D

BANE SEKULIĆ

LAT.

## BTV

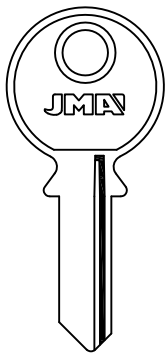

BTV-1I

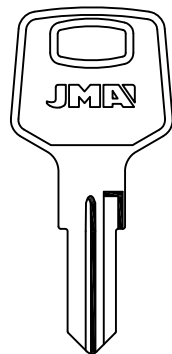

BTV-1D



BTV-2I



BTV-2D



BTV-3

SADV

## BUGA

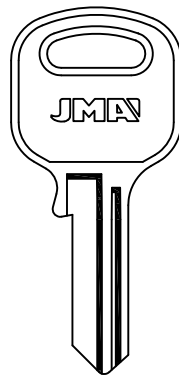

BAI-6

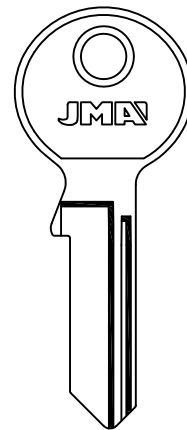

BAI-7

## BULAT

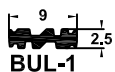
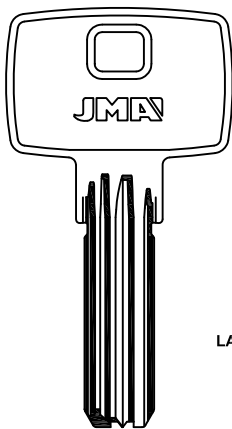

BUL-1

LAT.

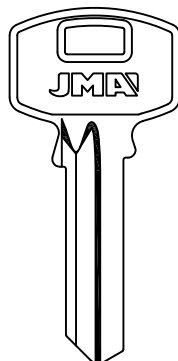

BUL-2D

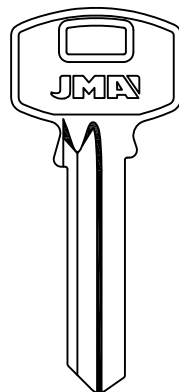

BUL-3D

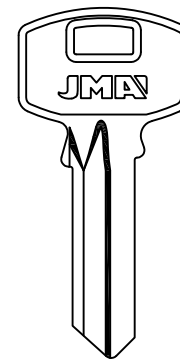

BUL-4D

## PARA-FOR:

BSS (SCG)

BTV (E)

BUGA (D)

BULAT (RUS)



**PARA-FOR:**

BULAT (RUS)

BURG (D)

| BULAT  |        | BURG                        |                             |
|--------|--------|-----------------------------|-----------------------------|
|        |        | <br><br>1/91/9...<br>0 AL 6 | <br><br>1/91/9...<br>0 AL 6 |
| BUL-5D | BUL-7D | BUR-11                      | BUR-1D                      |
|        |        | BUR-27D                     | BUR-21                      |
|        |        |                             | BUR-2D                      |
|        |        |                             | MELSMETALL                  |

| BURG  |        |       |            |
|-------|--------|-------|------------|
|       |        |       |            |
| BUR-3 | BUR-3D | BUR-4 | BUR-4D     |
|       |        | <br>  |            |
|       |        | BUR-5 | BUR-5D     |
|       |        |       |            |
|       |        |       | BUR-6      |
|       |        |       | MELSMETALL |

| BURG  |                             |   |                           |
|-------|-----------------------------|---|---------------------------|
|       | <br><br>1/91/9...<br>0 AL 6 | <br>ATL-BURGWACHTER-BUVA-HEWY<br>DURABLE-HOPPE-RITTAL-WSM | <br>CIBOX-HOPPE-KIND-ROTO |
| BUR-7 | BUR-8D                      | BUR-9   | BUR-9D                    |
|       |                             | BUR-10  | BUR-10D                   |



## BURG

PARA-FOR:

BURG (D)

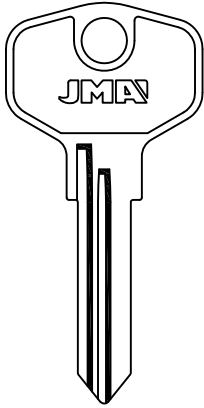

 BUR-11D

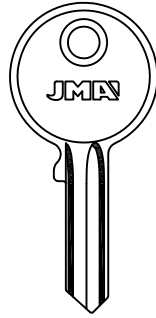

 BUR-12

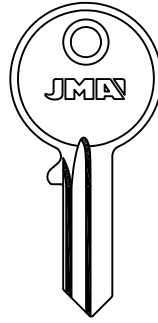

 BUR-13D

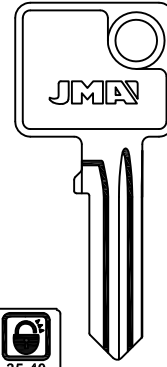

 BUR-14

 BUR-14D

222 C40

 BUR-19D

ANKE-BURG WACHTER

DESAL

ITEM-RITTAL

## BURG

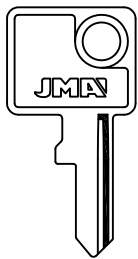

 BUR-15

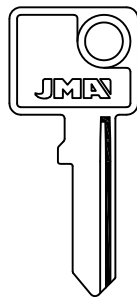

 BUR-16

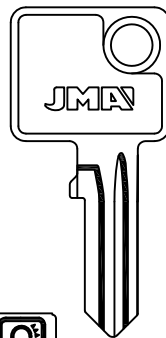

 BUR-17

 BUR-17D

222 C30

 BUR-20D



 BUR-18D

## BURG

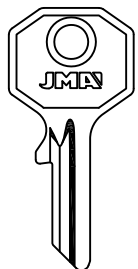

 BUR-21D

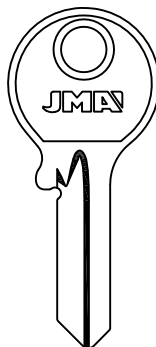

 BUR-22D

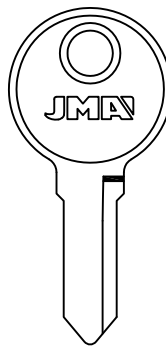

 BUR-24

 BUR-24D

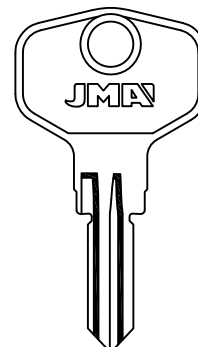

 BUR-25D

**JMA**<sup>®</sup>

Copyright by Alejandro Altuna S.A. 2014









ATENCIÓN: Concerniente a las marcas y denominaciones comerciales ver nota en índice.  
ATTENTION: Concerning the marks and commercial denominations see note in index.  
ATTENTION: Concernant les marques et dénominations commerciales voir la note dans l'index.  
ACHTUNG: Beziehen auf die marke und handelsname sehen sie die notiz im index.

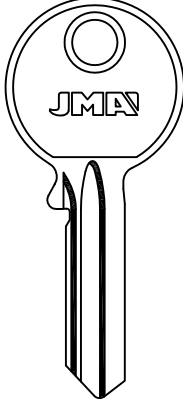
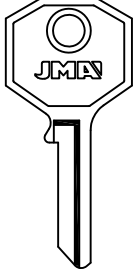
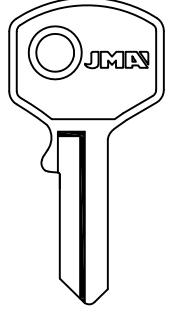
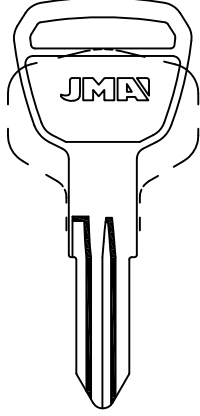





**PARA-FOR:**

- BURG (D)
- BUS (D)
- BUVA (D)
- CAB (I)
- CAM LOCK (USA)
- CARTERO (E)

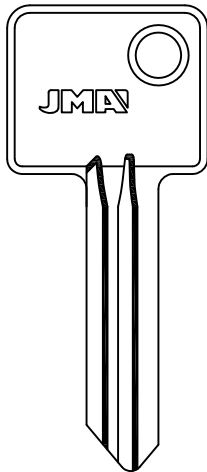
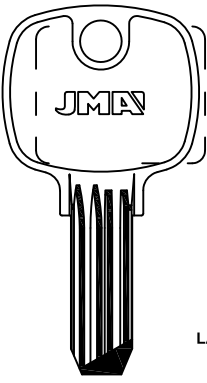
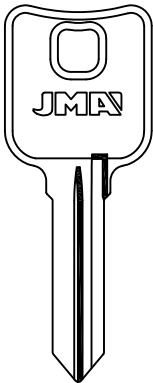
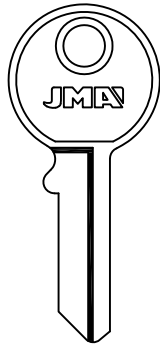

**BURG**

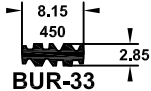
|   |   |   |   |
|---|---|---|---|
|  |  |  |  |
| LAT.  | LAT.  |   |   |
|  |   |   |   |
|  |  |   |  |
| <b>BUR-26D</b>  | <b>BUR-28</b>   | <b>BUR-29</b>   | <b>BUR-29D</b>  |
|   |   |   |  |
|   |   |   | <b>BUR-31D</b>  |

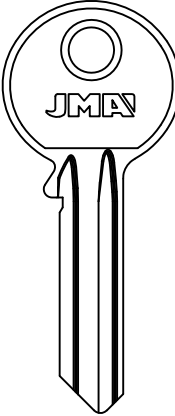

ZBK 70/74  
ZS 85/86

| <b>BURG</b>   |   |   | <b>BUS</b>  |
|---|---|---|---|
|   |   |   |   |
|   | LAT.  |   |   |
|   |  |  |   |
|  |  |  |  |
| <b>BUR-32D</b>  | <b>BUR-33</b>   | <b>BUR-34</b>   | <b>BUS-1</b>  |
|   |   |   | <b>KROST</b>  |

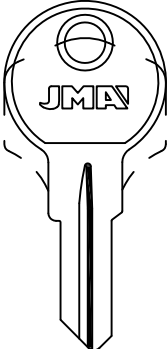

**BUVA**

|   |   |
|---|---|
|  |   |
|   |   |
|  |  |
| <b>BUVA-1</b>   | <b>BUVA-1D</b>  |

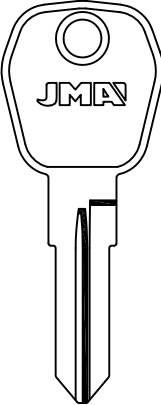

**CAB**

|   |
|---|
|  |
| LAT.  |
|  |
| <b>CAB-1D</b>   |

**CAM LOCK**

|   |
|---|
|  |
| LAT.  |
|  |
| <b>CML-1</b>  |

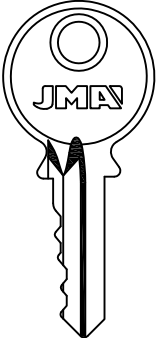
**CARTERO**

|   |
|---|
|  |
|   |
|  |
| <b>C</b>  |
| <b>AGA-FAC-STC</b>  |



**CARTERO**

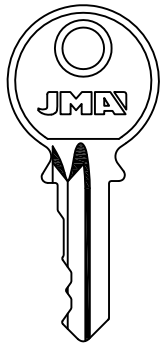

ABSA

**CAS CISMA**

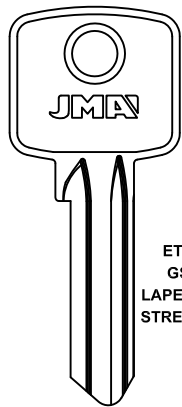

ETNA  
GSA  
LAPERCHE  
STREMLER

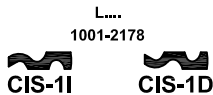

L....  
1001-2178

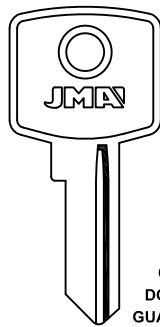

BY  
CAB  
DOMUS  
GUARDIAN  
MST  
SISO  
STIQAM  
TESTA



CIS-2



CIS-3

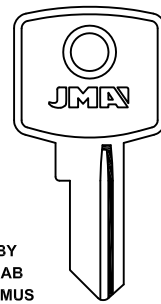

BY  
CAB  
DOMUS  
GUARDIAN  
MST  
SISO  
STIQAM  
TESTA



CIS-4



CIS-5

LAT.

**PARA-FOR:**

- CARTERO (E)
- CAS CISMA (I)
- CASH BOX (D)
- CAVERS (F)

**CAS CISMA**

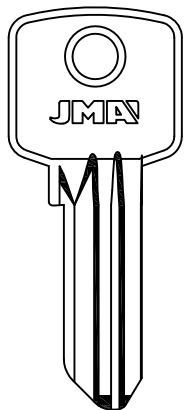

LAT.



KP2  
CIS-6D



CIS-7D

**CASH BOX**

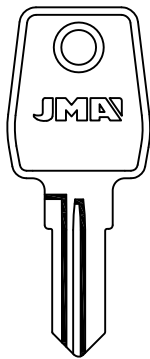

CSB-1D



0-1-2  
CSB-2D

ARREGUI-FAC-JOMA

**CAVERS**

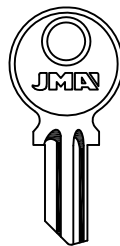

CA-1I

CITY

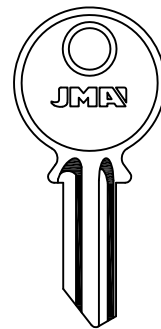

CA-2I



CA-10I

CITY-ZENICA

**CAVERS**

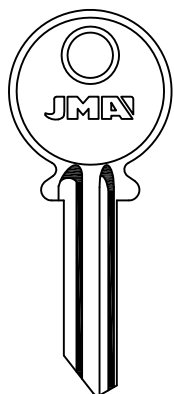

CA-3I



CA-9I

CITY-KVR

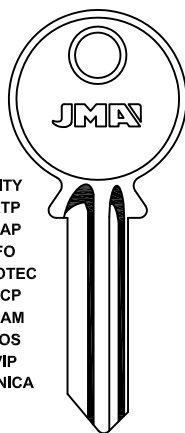

CITY  
ATP  
CAP  
FO  
PROTEC  
QCP  
SIAM  
SOS  
VIP  
ZENICA



CA-4I



CA-4D



CA-12I

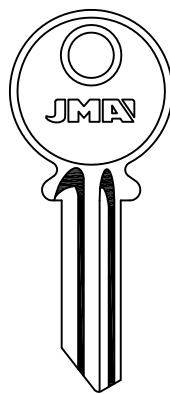

CA-5I



CA-11I

ZENITH-ZENICA

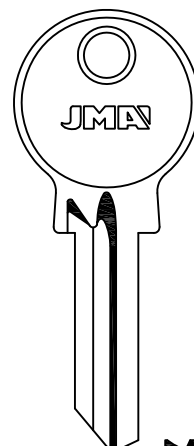

CA-6D



CA-13D

ZENITH-ZENICA



**PARA-FOR:**

- CAVERS (F)
- CAYS (E)
- CEMA (I)
- CENTURY (GB)
- CERRAMARC (E)

**CAVERS**

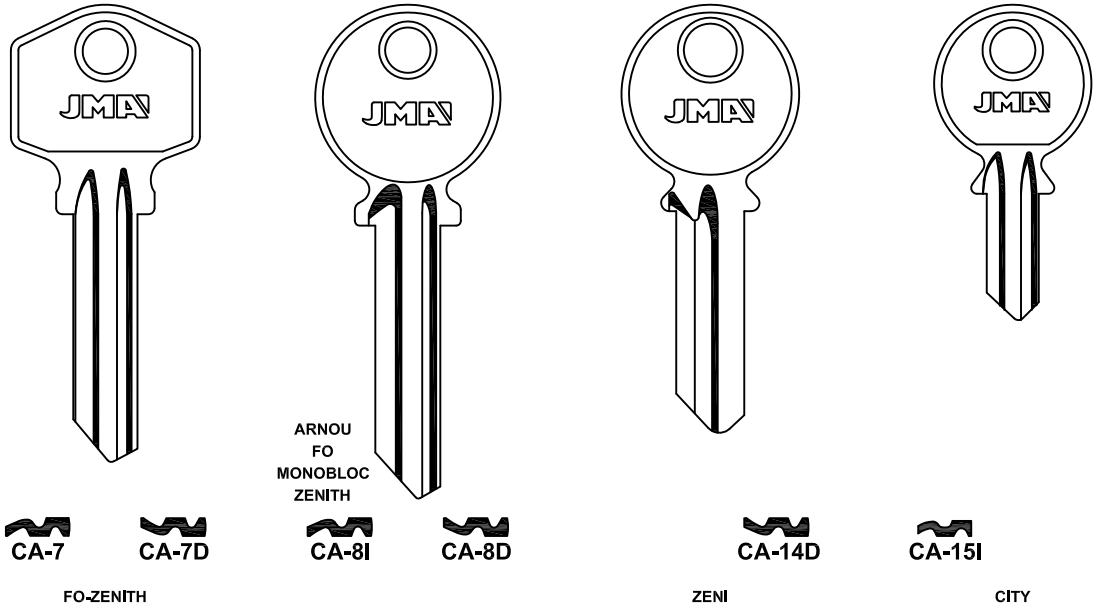

**CAYS**

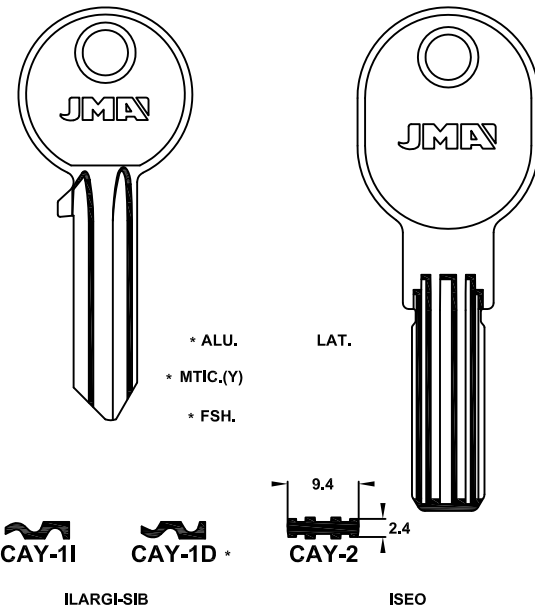

**CEMA**

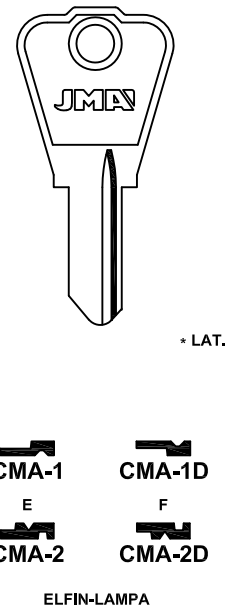

**CENTURY**

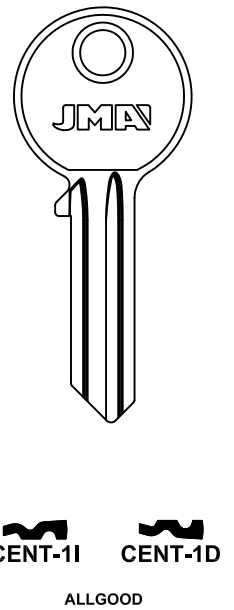

**CENTURY**

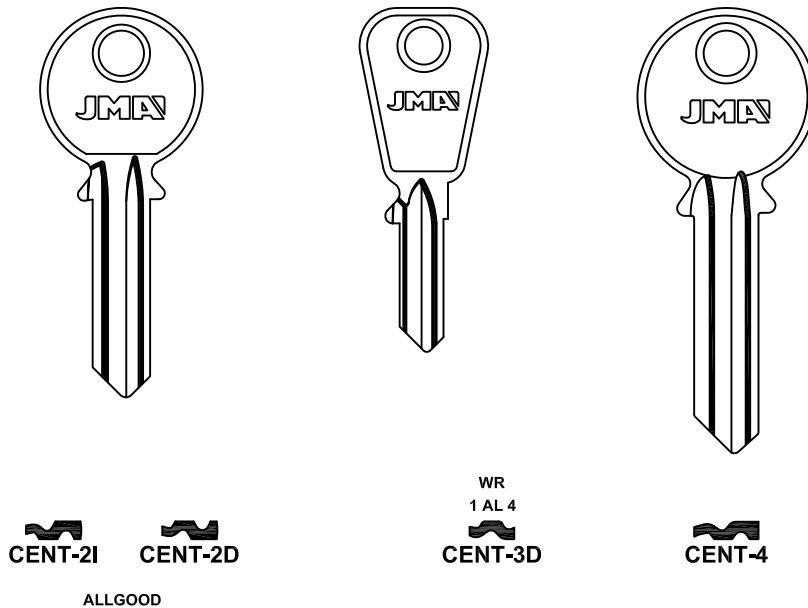

**CERRAMARC**

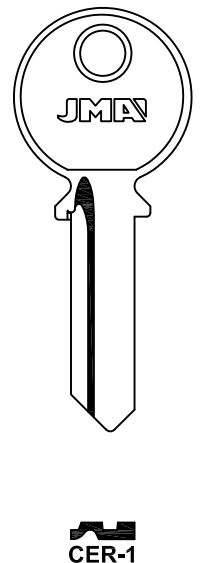



## CES

## PARA-FOR:

CES (D)

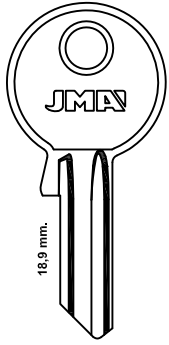

CE-1I

CE-1D

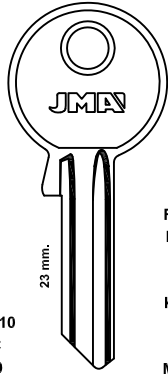

1C  
401-410  
10C  
1-10  
HLV  
911-950  
BODA  
ELZETT  
FRECOV  
KNAPP

CE-2I

CE-2D

ELZETT  
FRECOV  
HAFELE  
HANNO  
JOSTA  
KARDEX  
KIND  
KNAPP  
MAUSER  
NEMEF  
OJMAR  
SANTIS  
VOKO  
WASO  
WECO

CE-110

CE-108

CE-101D

CE-100D

CE-99D

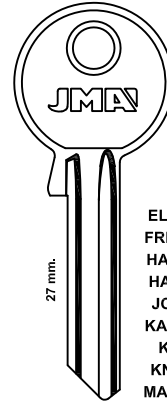

BODA  
ELZETT  
FRECOV  
KNAPP

CE-3I

CE-3D

ELZETT  
FRECOV  
HAFELE  
HANNO  
JOSTA  
KARDEX  
KIND  
KNAPP  
MAUSER  
NEMEF  
OJMAR  
VOKO  
WASO  
WECO

STUV

## CES

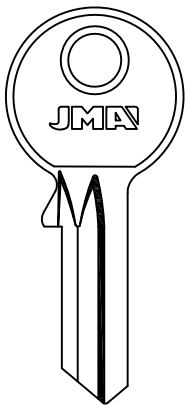

CE-4D

CE-5

CE-5D

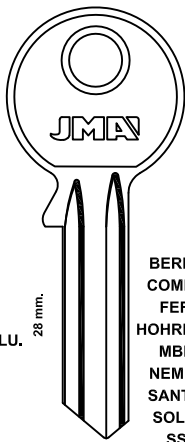

BERRY  
COMBA  
FEFI  
HOHRMANN  
MBB  
NEMEF  
SANTIS  
SOLID  
SS  
STUV  
TRITON

CE-92

CE-92D

CE-93D

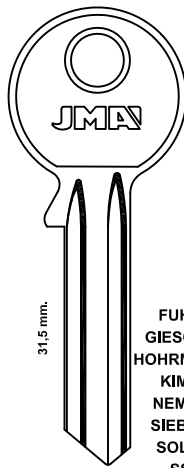

SOLID

CE-6I

CE-6D

FUHR  
GIESCHE  
HOHRMANN  
KIMA  
NEMEF  
SIEBAU  
SOLID  
SS  
STUV

CE-7I

\*CE-7D

CE-8D

\*MTIC.

CASMA-SPEEDAL

NEMEF

## CES

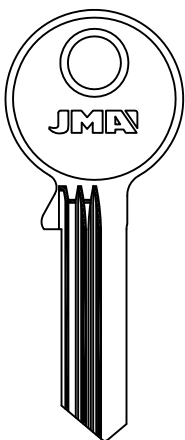

X23  
CE-9D

X24  
CE-10D

X25  
CE-11D

X26  
CE-12D

X27  
CE-13D

X28  
CE-14D

X29  
CE-15D

X30  
CE-16D

X31  
CE-17D

X32  
CE-18D

X33  
CE-19D

X34  
CE-20D

X35  
CE-21D

X36  
CE-22D

X37  
CE-23D

X38  
CE-24D

X39  
CE-25D

X40  
CE-26D

X41  
CE-27D

X42  
CE-28D

W23  
CE-29D

W24  
CE-30D

W25  
CE-31D

W26  
CE-32D

W27  
CE-33D

W28  
CE-34D

W29  
CE-35D

W30  
CE-36D

W31  
CE-37D

W32  
CE-38D

W33  
CE-39D

W34  
CE-40D

W35  
CE-41D

W36  
CE-42D

W37  
CE-43D

W38  
CE-44D

W39  
CE-45D

W40  
CE-46D

W41  
CE-47D

W42  
CE-48D

CE-118D

SOLID

**JMA**<sup>®</sup>

Copyright by Alejandro Altuna S.A. 2014



ATENCIÓN: Concerniente a las marcas y denominaciones comerciales ver nota en índice.  
 ATTENTION: Concerning the marks and commercial denominations see note in index.  
 ATTENTION: Concernant les marques et dénominations commerciales voir la note dans l'index.  
 ACHTUNG: Beziehen auf die marke und handelsname sehen sie die notiz im index.

PARA-FOR:

CES (D)

CES

33 mm.

1Z...1-100000

16  
CE-50

26  
CE-55

27  
CE-56

28  
CE-57

15  
CE-77

17  
CE-78

18  
CE-79

25  
CE-80

35  
CE-81

36  
CE-82

37  
CE-83

38  
CE-84

45  
CE-85

46  
CE-86

47  
CE-87

48  
CE-88

CE-49

CE-49D

CE-51

CE-51D

CE-52

BODA

LAT.

CES

31,5 mm.

LAT.

A5  
CE-61

A4  
CE-60

A3  
CE-59

A2  
CE-58

A1  
CE-54

B5  
CE-66

B4  
CE-65

B3  
CE-64

B2  
CE-63

B1  
CE-62

C5  
CE-71

C4  
CE-70

C3  
CE-69

C2  
CE-68

C1  
CE-67

D5  
CE-76

D4  
CE-75

D3  
CE-74

D2  
CE-73

D1  
CE-72

K  
CE-90D

CE-53D

HÄFELE

BODA

CES

\* LAT.

LAT.

CE-89

CE-89D

\* CE-133

CE-94

CE-96

CE-97



CES

PARA-FOR:

CES (D)

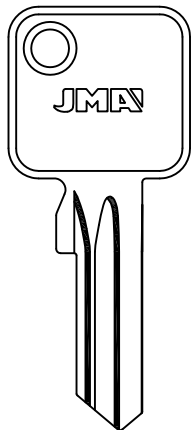

CASMA-SPEEDAL

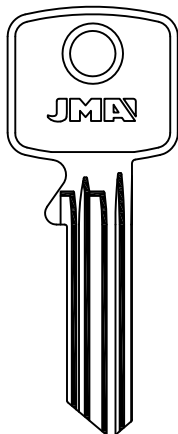

NEMEF

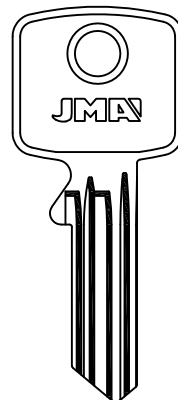

CES

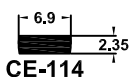
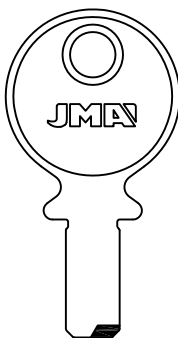
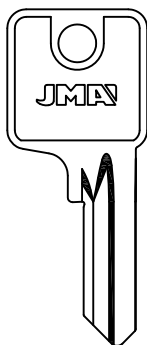

LAT.

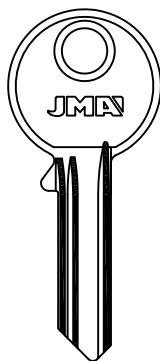

WS 401-410

CE-130

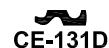
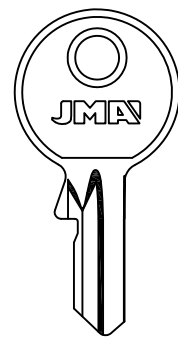

CES

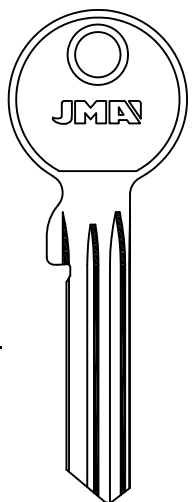

LAT.

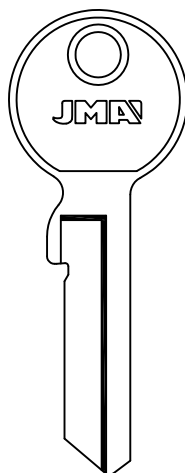
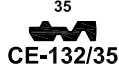
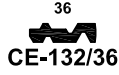
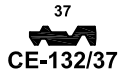
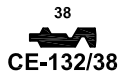
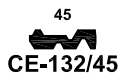
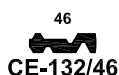
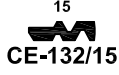
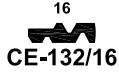
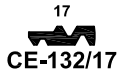
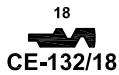
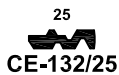
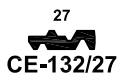

CE-134

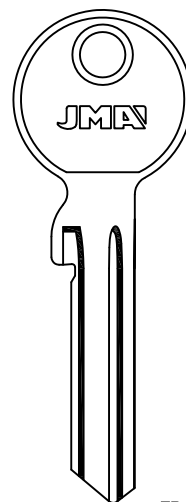

ALP.

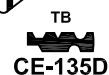









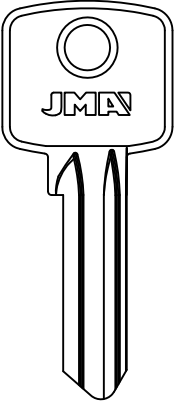
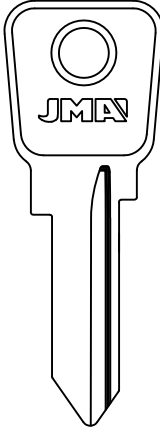
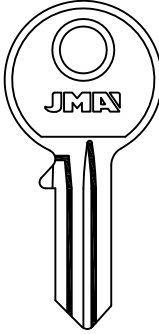
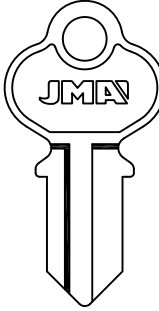

CE-135D









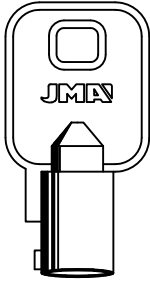
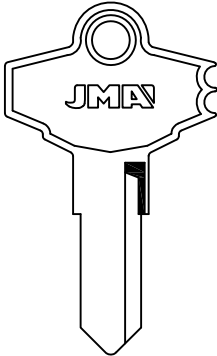
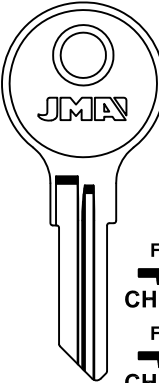
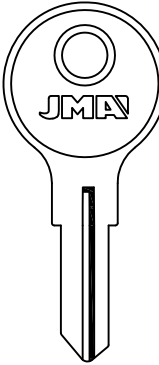

**PARA-FOR:**

- CHAVO (P)
- CHELIABINSK (RUS)
- CHEYLOCK (HK)
- CHICAGO (USA)
- CHUBB (GB)
- CIEF (F)
- CIELS (F)

| CHAVO   | CHELIABINSK  | CHEYLOCK   | CHICAGO  |
|---|--|--|--|
|        |         |         |   |
|  CHA-2 |  CHTZ-1 |  CHEK-1 |  CHI-1<br> CHI-2<br> CHI-3<br> CHI-4<br> CHI-5<br> |





**CHICAGO**

|   |   |   |   |
|---|---|---|---|
|   |                         |   |           |
|  CHI-1T<br>ACE-ADEMCO-AGA-ALPHA<br>EURO LOCKS-FORT-GEM-L & F |  CHI-6<br>ILLINOIS ODA |  FR CHI-7D<br> FR CHI-8D<br> XF CHI-9D<br> XF CHI-10D |  CHI-12D |

**CHUBB**

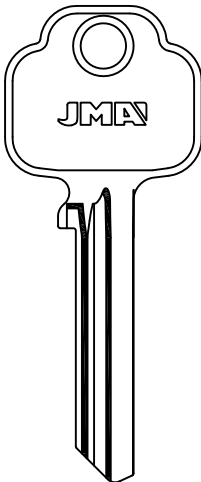
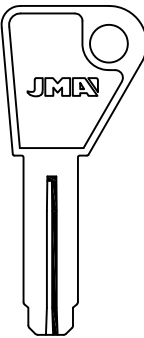
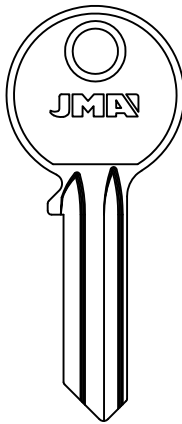
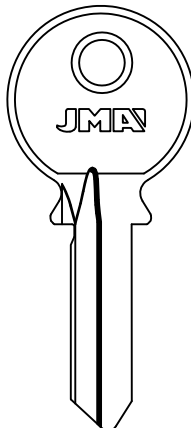
**CIEF**

**CIELS**

|  |   |   |  |
|--|---|---|--|
|         |                      |       |         |
|  CHU-1D |  CHU-10<br>AVA-CHUBB |  CF-1 |  CIE-1D |



## CIFIAL

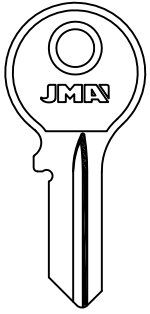

CIF-1D

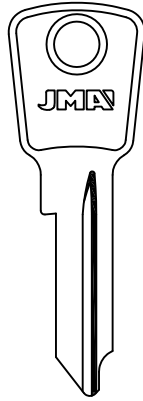

CIF-2D

LEFEBURE

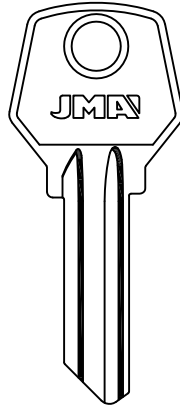

CIF-3

CIF-3D

EFER

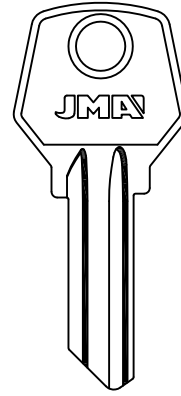

CIF-4

EFER

## PARA-FOR:

CIFIAL (P)

CILA-GENTILI (I)

CINA (RC)

CISA (I)

## CILA-GENTILI

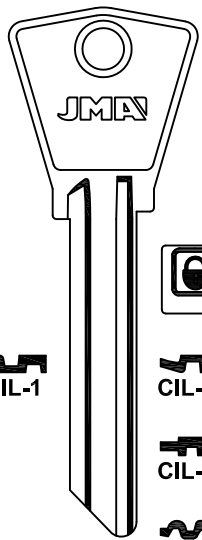

CIL-1



CIL-1D

CIL-2D

CIL-3D

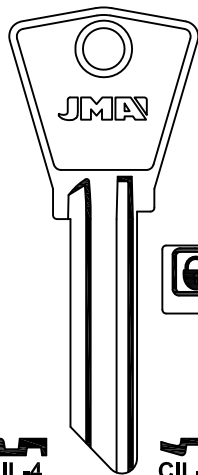

CIL-4



CIL-4D

CIL-5D

## CINA

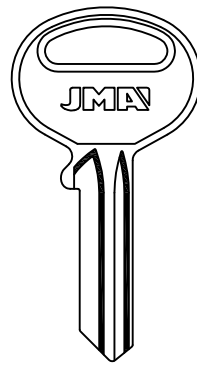

ALI-1

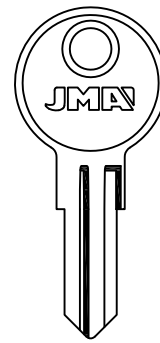

CIN-1

CIN-1D

## CINA

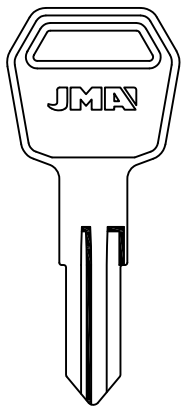

CIN-2

CIN-2D

## CISA

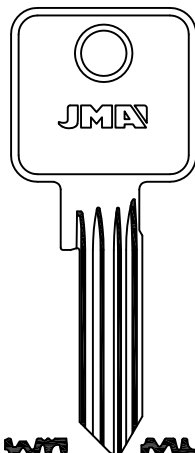

CI-11

CI-1D

CI-39D

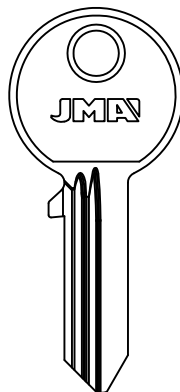

CI-4I

CI-4D

TZAFRER

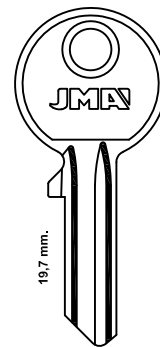

19,7 mm.



CI-4IP



CI-4DP

ABUS

**JMA**<sup>®</sup>

Copyright by Alejandro Altuna S.A. 2014



ATENCIÓN: Concerniente a las marcas y denominaciones comerciales ver nota en índice.  
 ATTENTION: Concerning the marks and commercial denominations see note in index.  
 ATTENTION: Concernant les marques et dénominations commerciales voir la note dans l'index.  
 ACHTUNG: Beziehen auf die marke und handelsname sehen sie die notiz im index.

PARA-FOR:

CISA (I)

CISA

23.2 mm.

.....1 AL 6

CI-5IP CI-5DP CI-6I \*CI-6D CI-44D CI-58D CI-7D CI-14 CI-17

ABUS ESCO ESSENDIA GEFI GETE GTV SCHUCO STANDARD

\*MTIC. ABUS CHAVO ESCO ESSENDIA ITO GEFI GETE GTV NB SCHUCO STANDARD

A/AZIZA/Z.....  
000001-030198

BATU-KUNERT JPM ABUS-ASTRAL-BRICARD

CISA

CI-19D CI-20 CI-20D CI-21 CI-25 CI-26 CI-30 CI-31 CI-32 CI-33 CI-35 CI-56 CI-59 CI-60 CI-67

LAT.

ABUS-ASTRAL-AXIS

CISA

CI-22D CI-23D CI-24 CI-28D

ABUS ABUS



# CISA

PARA-FOR:

CISA (I)

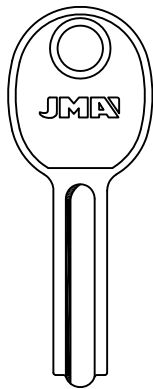

CI-41

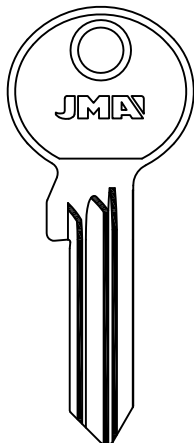

A  
CI-43D

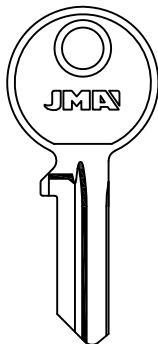

CI-45D

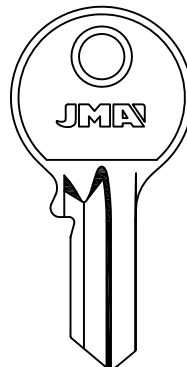

CI-46D

ABUS

# CISA

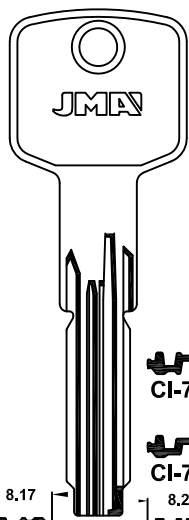

LAT.

8.17  
2.98  
CI-48

ABUS

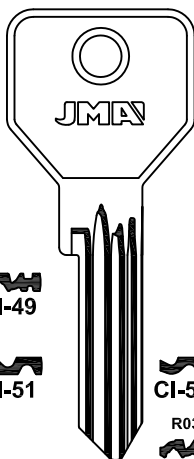

CI-49

CI-51

CI-72

R032  
CI-61

CI-51D

R033  
CI-55D

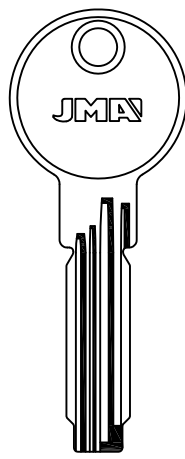

LAT.

8.2  
2.85  
CI-57

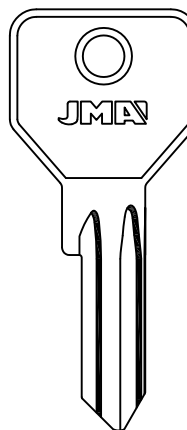

CI-62

CI-62D

# CISA

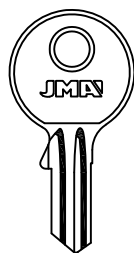

CI-65

ABUS-ALA

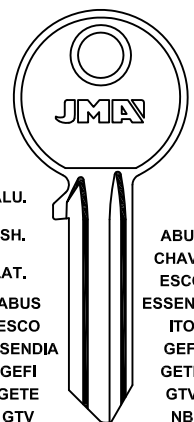

ALU.

\* FSH.

\* LAT.

ABUS

ESCO

ESSENDIA

GEFI

GETE

GTV

NB

SCHUCO

STANDARD



50-60

CI-1L

\*\* CI-DL

ABUS

CHAVO

ESCO

ESSENDIA

ITO

GEFI

GETE

GTV

NB

SCHUCO

STANDARD

TREE

CI-21

20  
CI-9D

04-05-07  
CI-11D

33  
CI-13

CI-15

R002  
CI-18

R005-19  
CI-29

A  
CI-2

02  
CI-8D

08  
CI-10D

11  
CI-12

CI-15D

CI-16D

CI-27

CI-34

R007  
CI-36

CI-38D

CI-42

CI-53

CI-63

CI-34D

CI-70

CI-69

\* CI-66D

CI-64D











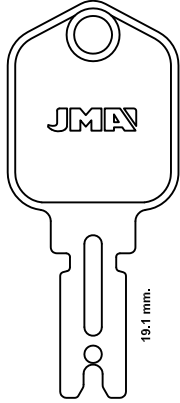

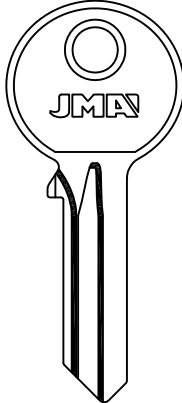

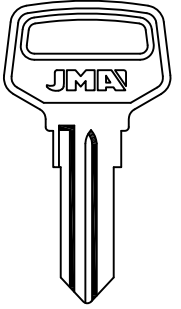
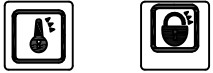

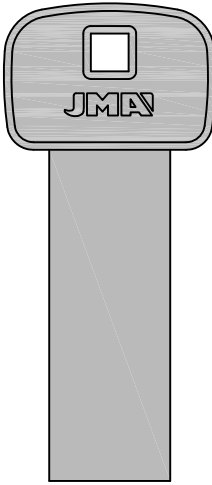

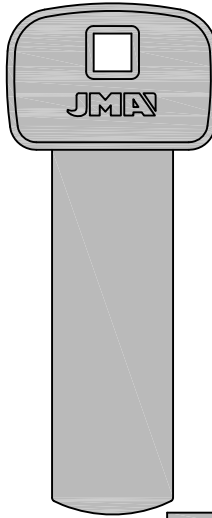

CI-63

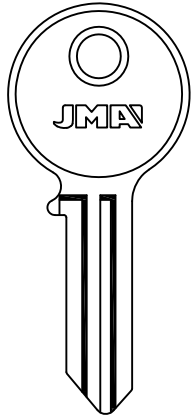
CI-63D

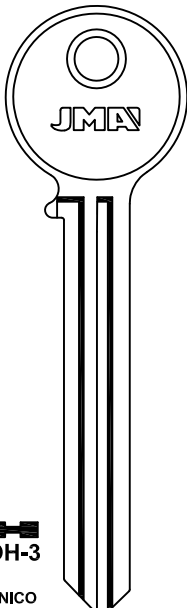

**PARA-FOR:**

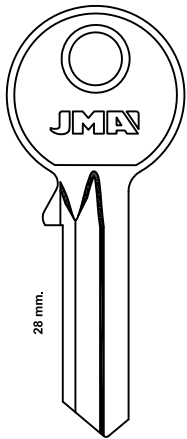
- CLARK FORK LIFT  
(USA)
- CLASSIC
- CLAUSOR (E)
- CLEMSA (E)
- COHNKO (RUS)
- COM (D)











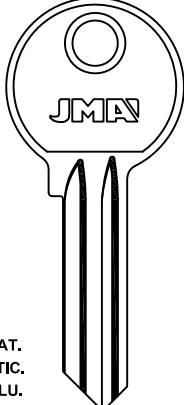
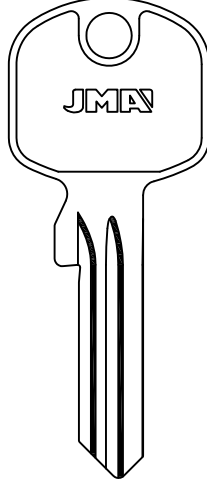
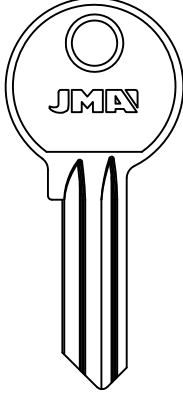





| CLARK FORK LIFT   | CLASSIC  | CLAUSOR  |
|---|--|--|
|  <p>19.1 mm.<br/>LAT.</p>  <p><b>CLF-1</b><br/>YALE</p>   |   <p><b>CLS-1D</b></p>         |  <p>ALU.</p>   <p><b>CL-1I</b><br/>BRABANTIA</p>          |
| CLEMSA  |  | COHNKO   |
|     <p>MG-6I    MG-6S    MG-6D</p> |  <p>PLAS.</p>  <p>MG-9</p> |   <p>COH-1</p>  <p>COH-2    COH-2D</p> <p>SONICO</p> |
| COHNKO  |  | COM  |
|   <p>COH-3<br/>SONICO</p>   |   <p>COH-4</p>               |  <p>28 mm.</p>  <p>COM-1D</p>  |













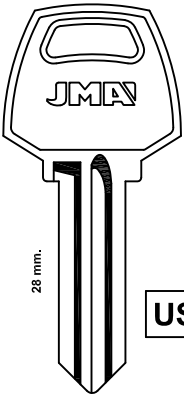
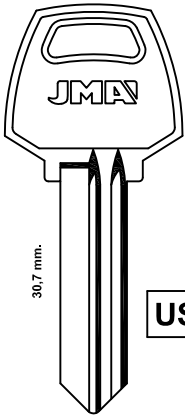
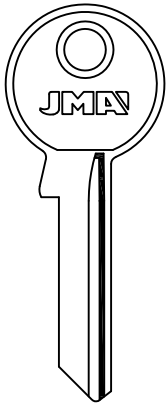
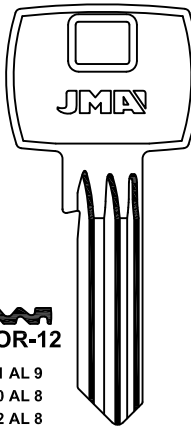

## CORBIN

PARA-FOR:  
CORBIN (I)









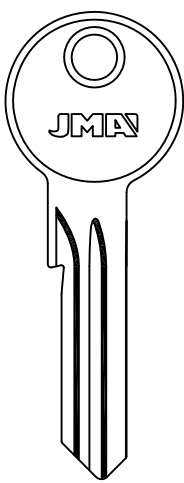
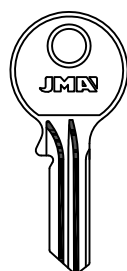
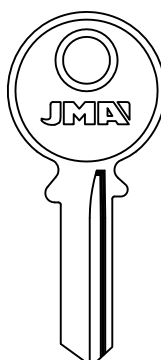

|   |   |   |   |   |   |
|---|---|---|---|---|---|
|  | ALUNORM   |   |   |    |  |
|   | CRC-CAMBOA  |   |   |   |   |
|   | DOM   |   |   |   |   |
|   | ESCO  |   |   |   |   |
|   | EURONORM  |   |   |   |   |
|   | HEGO  |   |   |   |   |
|   | HESTE   |   |  |   |   |
|   | ISSERSTEDT  |   |   |   |   |
|   | KAWE  |   |   |   |   |
|   | LITTO   |   |   |   |   |
|   | MERMIER   | * COR-48  |  |   |   |
|   | MUKRA   |   |   |   |   |
|   | NEMEF   |   |   |   |   |
|   | NOVOFERM  |   |   |   |   |
|   | STREMLER  | COR-49  |  |   |   |
|   | SUL   | BWS   |   |   |   |
|   | THONE   |   |   |   |   |
|   | VERSCO  | COR-69  |  |   |   |
|   | ZECE  |   |   |   |   |
| * LAT.  |   |   |   |   |   |
| ** MTIC.  |   |   |   |   |   |
| ** ALU.   |   |   |   |   |   |
|   |  |  |  |  |  |
| COR-11  | COR-1D  | COR-80  | COR-36D   | COR-21  | COR-2D  |
|   |  |  |  |    |  |
| COR-3   | COR-3D  | COR-79  | COR-76D   | COR-1GD   | COR-16D   |

ESCO-KAWE-LITTO-NEMEF

## CORBIN

|   |   |   |   |
|---|---|---|---|
|   |   |   |   |
| 28 mm.  | 30,7 mm.  |   |   |
|  |  |   |   |
| COR-7   | COR-9   |   | COR-12  |
|  |  |  |   |
| COR-8   | COR-10  | COR-11  | COR-13  |
|   |   |  |  |
|   |   | COR-11D   | COR-13D   |
|   |   |   |   |
|   |   |   | COR-72  |
|   |   | MASTER  | EUROPARTNER-FUCHS   |

## CORBIN

|   |   |   |   |   |
|---|---|---|---|---|
|   | 027   |   |    |  |
|   | * COR-64  |   |   |   |
|   | 029   |   |   |   |
|   | * COR-65  |   |   |   |
|   | 038   |   |   |   |
|   | * COR-66  |   |   |   |
|   |  |   |   |   |
|   | * COR-67  |   |   |   |
|   |  |   |   |   |
|   | * COR-68  |   |   |   |
|   |  |   |   |   |
|   | * COR-71  |   |   |   |
|   |   | * LAT.  |   |   |
|  |  |  |    |  |
| COR-15D   | COR-73  | COR-74  | COR-17D   | COR-20  |
|   |   |   |  | COR-20D   |
| TESIO   |   |   |   |   |



**PARA-FOR:**

CORBIN (I)

**CORBIN**

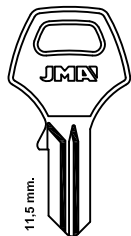

20-25  
1 AL 6

**COR-20/25**

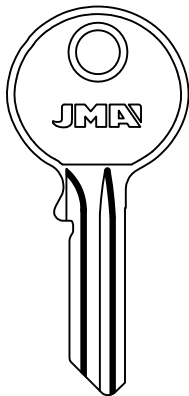

**COR-23D**

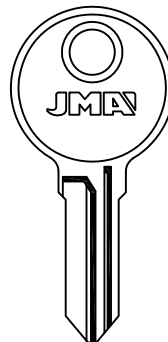

**COR-24**

**COR-24D**

CHANGE-O-MATIC

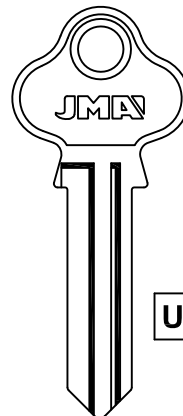

USA

**COR-25I**

**COR-25**

SKILMANN

**CORBIN**

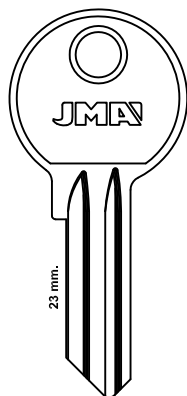

.....1 AL 7  
.....2 AL 7

**COR-26**

ESCO-EURONORM-KAWE-MUKRA

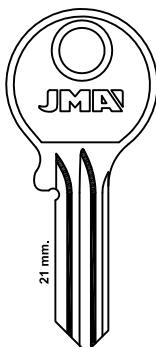

**COR-27D**

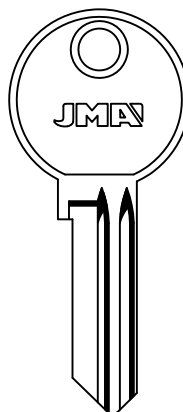

**COR-28**

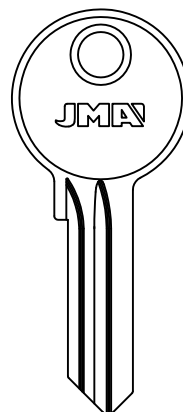

LAT.

**COR-29D**

**CORBIN**

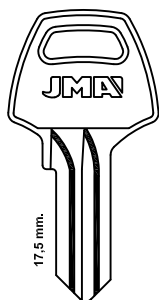

1 AL 9  
1 AL 7  
2 AL 7

**COR-30**

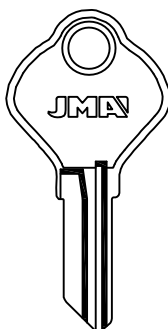

**COR-31**

CCL

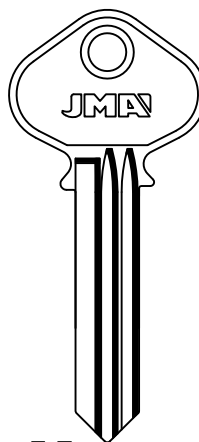

LAT.

**COR-32**

**COR-33**

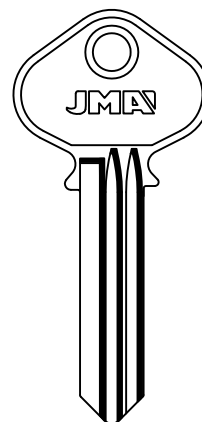

LAT.

**COR-34**



## CORBIN

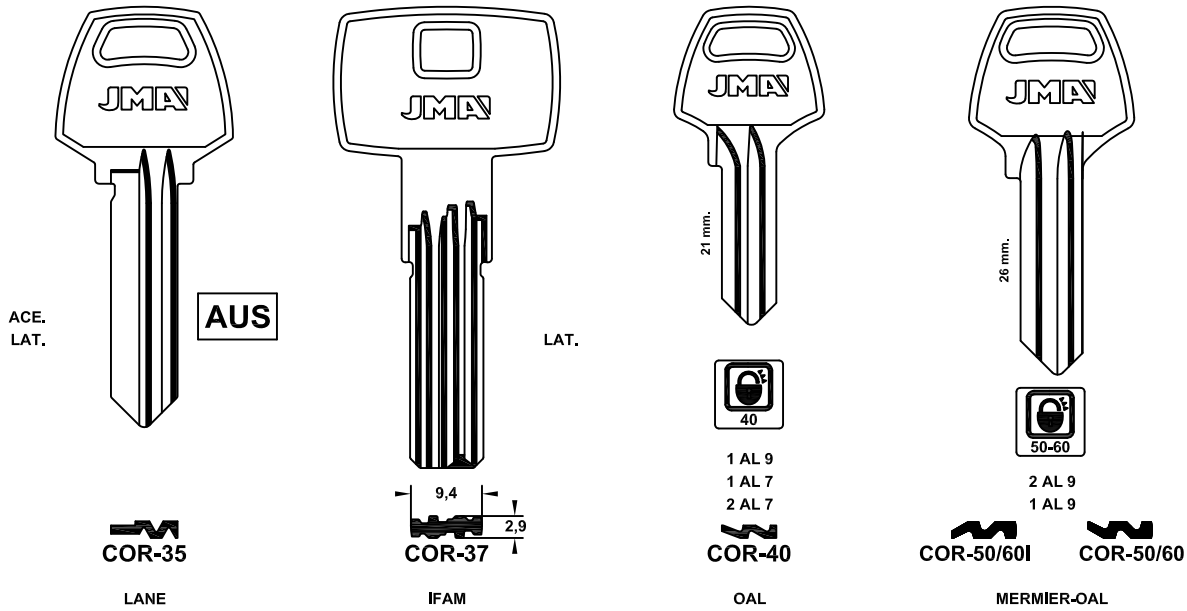

## CORBIN

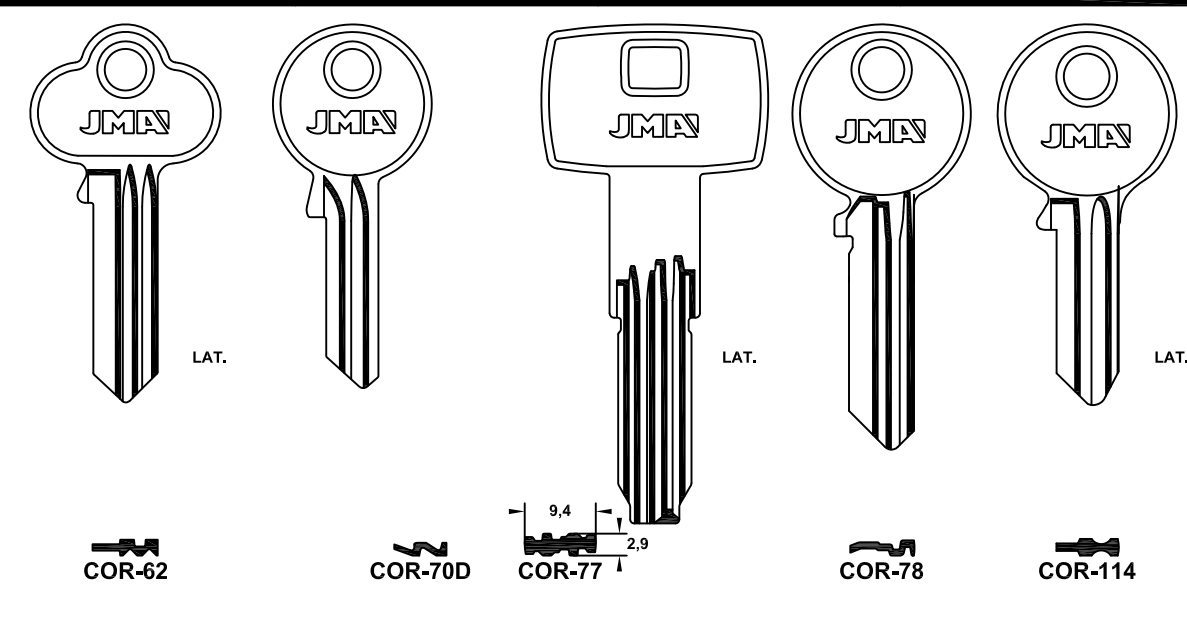

## CORBIN

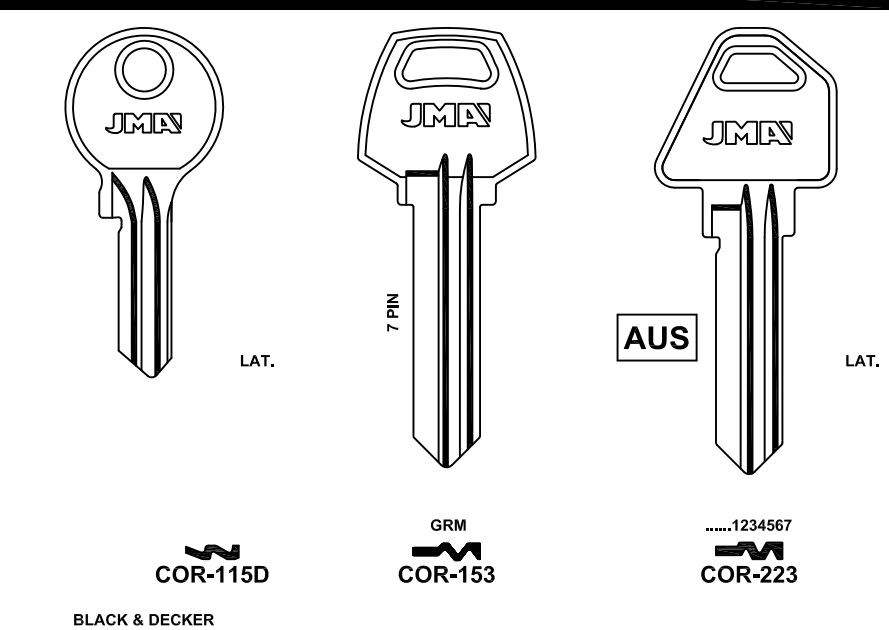

## CORONA

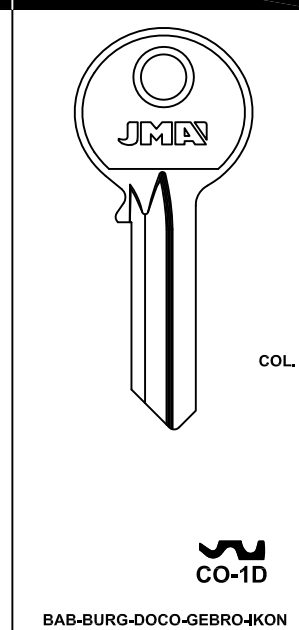

## PARA-FOR:





CORBIN (I)

CORONA (D)



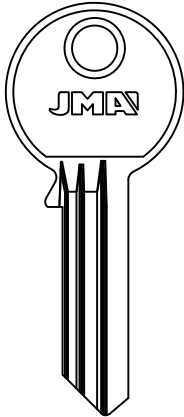
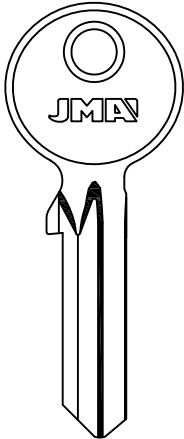
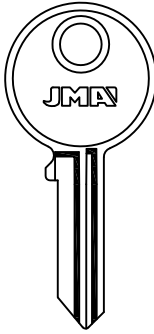
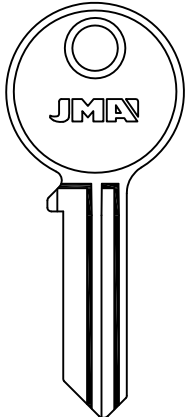





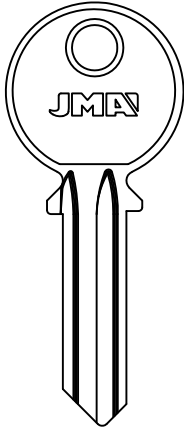
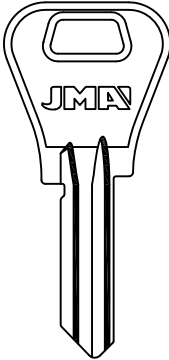
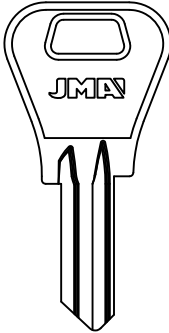
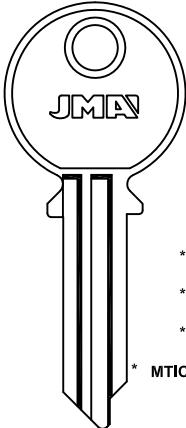

**PARA-FOR:**

- CORONA (D)
- COTICO (D)
- CRAZY LOCKS (RC)
- CUBELLS (E)
- CVL (E)
- DAD (F)











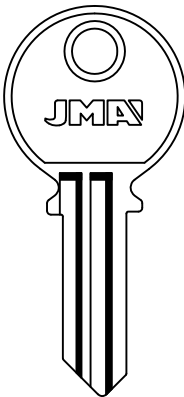
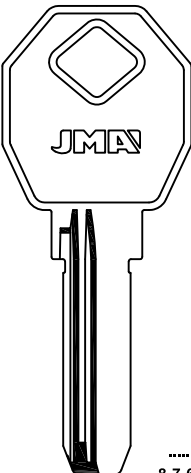
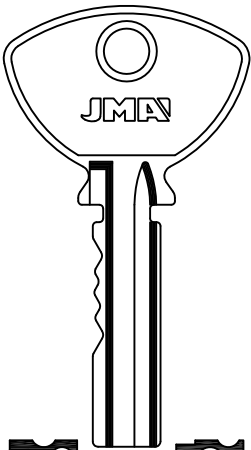
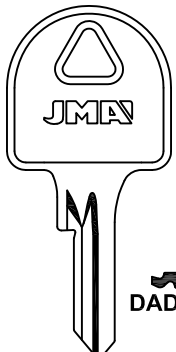

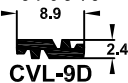
| CORONA   | COTICO  | CRAZY LOCKS  | CUBELLS  |
|--|---|--|--|
|                       |            |           |           |
| <br>M<br>CO-M<br>IKON | <br>COT-1D | <br>CLK-1 | <br>CUB-1 |

**CVL**

|   |   |  |   |
|---|---|--|---|
|             |               |            |             |
| LAT.<br>ALU.  | LAT.<br>ALU.  |  | * FSH.<br>* LAT.<br>* ALU.<br>* MTIC.(D-C)  |
| <br>CVL-1I | <br>CVL-1D   | <br>CVL-2I  | <br>CVL-5I |
| SERRALLER   |   | UCEM   |   |
| <br>CVL-2D | <br>CVL-3D | <br>CVL-3I | <br>CVL-5D |
| AUMON-CAYS-CAZORLA-EURO<br>FERMOD-JJ-PP-QCM   |   |  |   |

**CVL**

**DAD**

|   |  |   |   |
|---|--|---|---|
|            |             |             |            |
| LAT.  | LAT.   |   |   |
| <br>CVL-6  | <br>CVL-9D  | <br>DAD-1I  | <br>DAD-3D |
| <br>CVL-8D | <br>DAD-2I | <br>DAD-1D | <br>DAD-4D |
|   |  | <br>DAD-2D | <br>DAD-5D |
|   |  | <br>DAD-6D |   |
|   |  | DECAYEUX  |   |
|   |  | ARFE-DECAYEUX   |   |

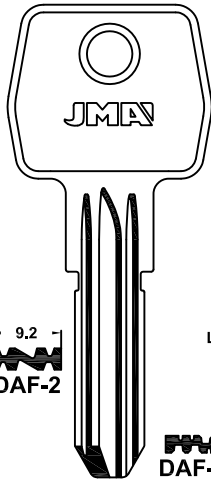
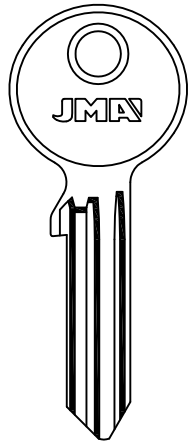

**DAF**

DAF-3D



DAF-4D

LAT.

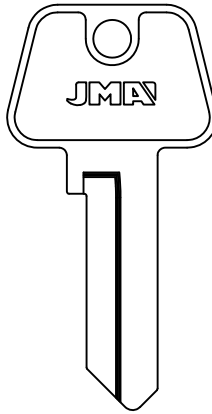
**DEFA**

DEF-1D

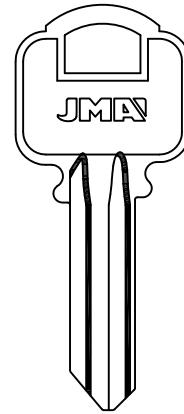
**DEKABA**

DEK-2



DEK-7D

MAUER

**PARA-FOR:**

DAF (TR)

DEFA (N)

DEKABA (BG)

DELAPORTE (F)

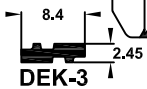
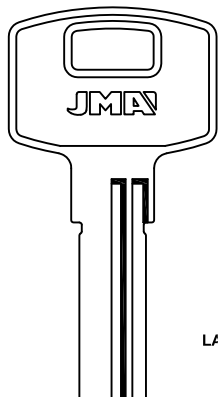
**DEKABA**

DEK-3

E2



DEK-8

MAUER

LAT.

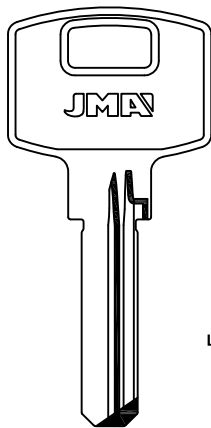

DEK-4

MAUER

LAT.

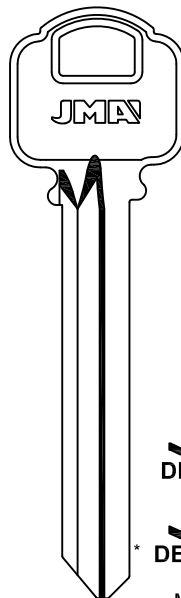

DEK-6D



DEK-14D

MAUER

\* LAT.

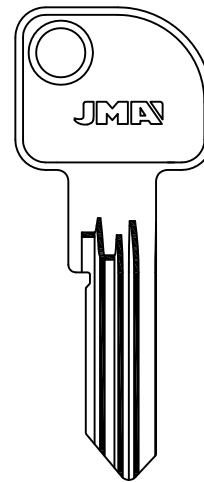

DEK-9D

MAUER

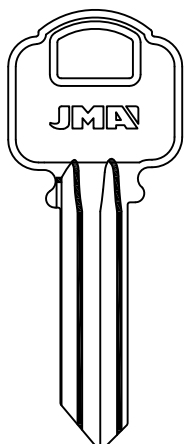
**DEKABA****DELAPORTE**

DEK-10

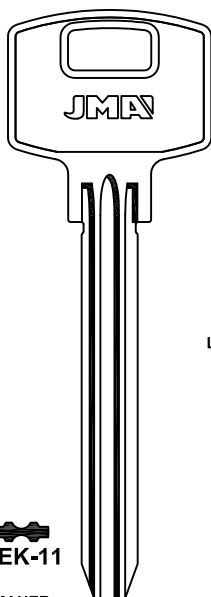

DEK-11

MAUER

LAT.

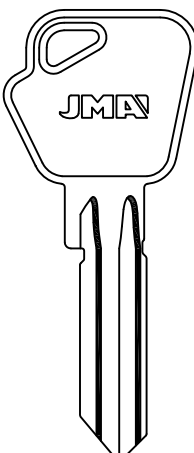

DEK-13

MAUER

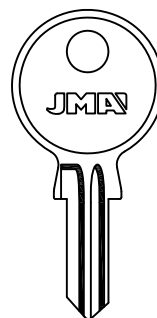

2501-2550



DLP-1

DIRAK-EMKA

**JMA**<sup>®</sup>

Copyright by Alejandro Altuna S.A. 2014



ATENCIÓN: Concerniente a las marcas y denominaciones comerciales ver nota en índice.

ATTENTION: Concerning the marks and commercial denominations see note in index.

ATTENTION: Concernant les marques et dénominations commerciales voir la note dans l'index.

ACHTUNG: Beziehen auf die marke und handelsname sehen sie die notiz im index.

**PARA-FOR:**

- DELAPORTE (F)
- DELCA (GR)
- DEXTER (I)
- DIAMOND (RC)
- DIEBOLD (D)
- DIERRE (I)
- DIMITROVGRAD (RUS)
- DOM (D)

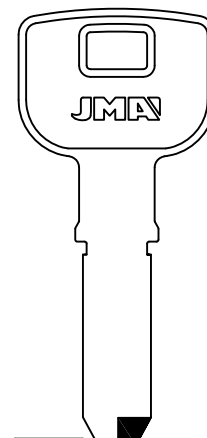
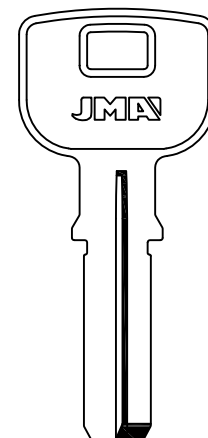
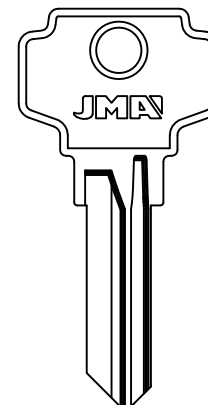
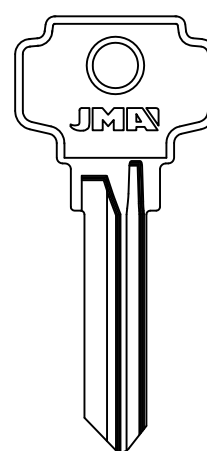
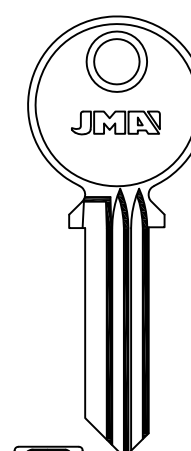
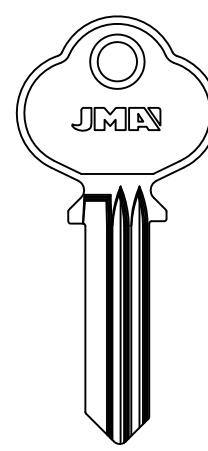
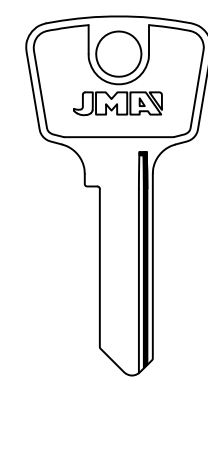
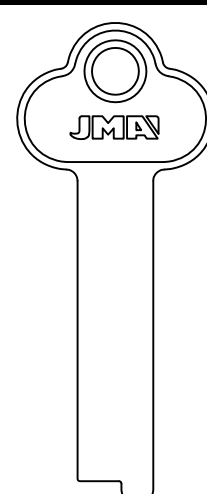
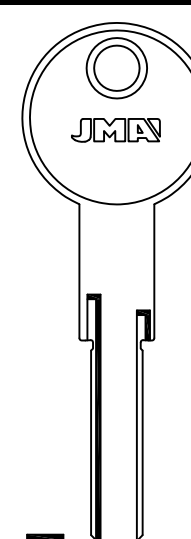
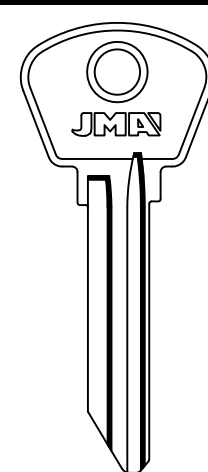
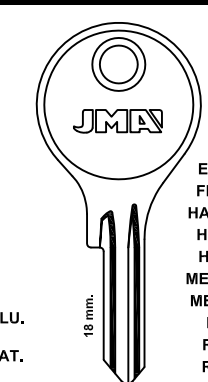
| DELAPORTE   | DELCA   |  | DEXTER   |
|---|---|--|--|
|  <p>DLP-2</p>                                |  <p>LAT</p> <p>DLC-1<br/>9<br/>DLC-2<br/>2.4</p> <p>GEVY</p> |  <p>LAT</p> <p>8.85<br/>DLC-3<br/>2.45</p> <p>GEVY</p> |  <p>ALU.</p> <p>0 AL 7<br/>T<br/>0 AL 9<br/>0 AL 9</p> <p>DX-5 DX-5D</p>  |
| DEXTER  | DIAMOND   |  |  |
|  <p>0 AL 7<br/>0 AL 9</p> <p>DX-6 DX-6D</p> |  <p>DIA-1</p>   |  <p>DIA-2</p>   |  <p>DIA-3</p>  |
| DIEBOLD   | DIERRE  | DIMITROVGRAD   | DOM  |
|  <p>LAT.</p> <p>DIE-1</p>                  |  <p>LAT.</p> <p>DR-1</p> <p>ATRA</p>                       |  <p>DM-1</p>   |  <p>18 mm.</p> <p>* ALU.<br/>* LAT.<br/>* FSH.</p> <p>BTV<br/>DAD<br/>ESAFE<br/>FECOR<br/>HAEFELE<br/>HEKNA<br/>HUWIL<br/>MECALUX<br/>METEOR<br/>MLM<br/>RENZ<br/>RUKA<br/>SCHLEGEL<br/>STS</p> <p>2D 001-222<br/>5A 0001-2600<br/>9A 0001-5200<br/>1D 601-654</p> <p>DOM-11 * DOM-1D</p> |



# DOM

PARA-FOR:

DOM (D)

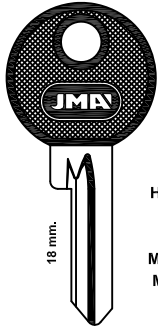

BTV  
DAD  
ESAFE  
FECOR  
HAEFELE  
HEKNA  
HUWIL  
MECALUX  
METEOR  
MLM  
RENZ  
RUKA  
SCHLEGEL  
STS

2D 001-222  
5A 0001-2600  
9A 0001-5200  
1D 601-654



DOM-1D.P

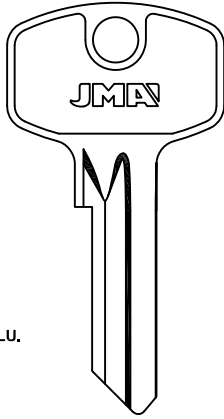

ALU.



DOM-2D

MOREAUX-STUV

C  
1301-1500  
C  
1001-1200  
CL  
001-250  
GP  
001-250



DOM-3I



DOM-4



DOM-8D



DOM-3D



DOM-4D



DOM-8D

CHRIST

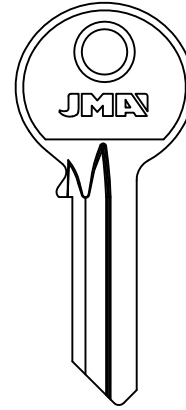

DOM-5D

STEIGA-STUV-VIKI

# DOM

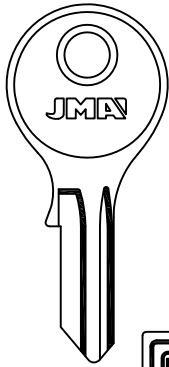

DN  
001-120  
80138-80728  
80761-83242



DOM-6I



DOM-6D

BARRO-IDEAL-TM

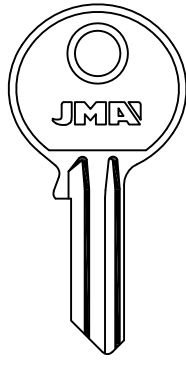

DOM-7I

EV  
0001-2840  
GD  
0001-1000  
4C  
0001-3000



DOM-7D

HOHRMANN



DOM-9



EV...1-2840  
GS...1-1000  
FT...1-1000  
CQ...301-400  
...1-1000



DOM-9D

NOBO

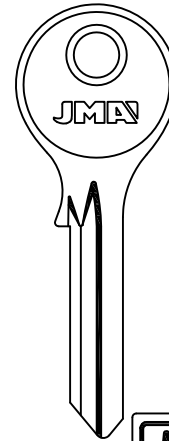

DOM-10D

# DOM

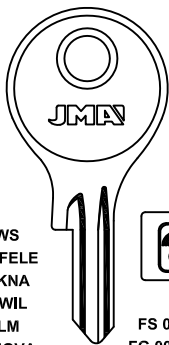

CWS  
HAEFELE  
HEKNA  
HUWIL  
MLM  
MENOVA  
METEOR  
RUKA  
SINJET  
STS

1D 058-114



DOM-11I

FS 01-60  
FG 001-615  
4A 001-182  
3A 01-82  
CF 001-140  
DB 001-148  
2A 01-34  
1D 01-57  
1D 501-560



DOM-11D

NOBO

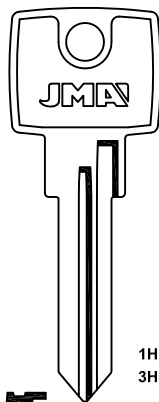

DOM-12

1H 0001-4088  
3H 0001-0600



DOM-12D

ASPA

1H 0001-4088  
3H 0001-0600



DOM-48

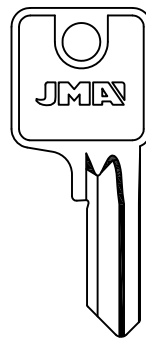

DOM-13D

DC...1-1800  
K.. 1-50  
GD...1-1800  
GZ...1-1800  
3E...1-350

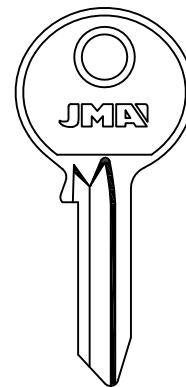

DOM-14D

FA-GZ  
0001-3948



**PARA-FOR:**

DOM (D)

**DOM**

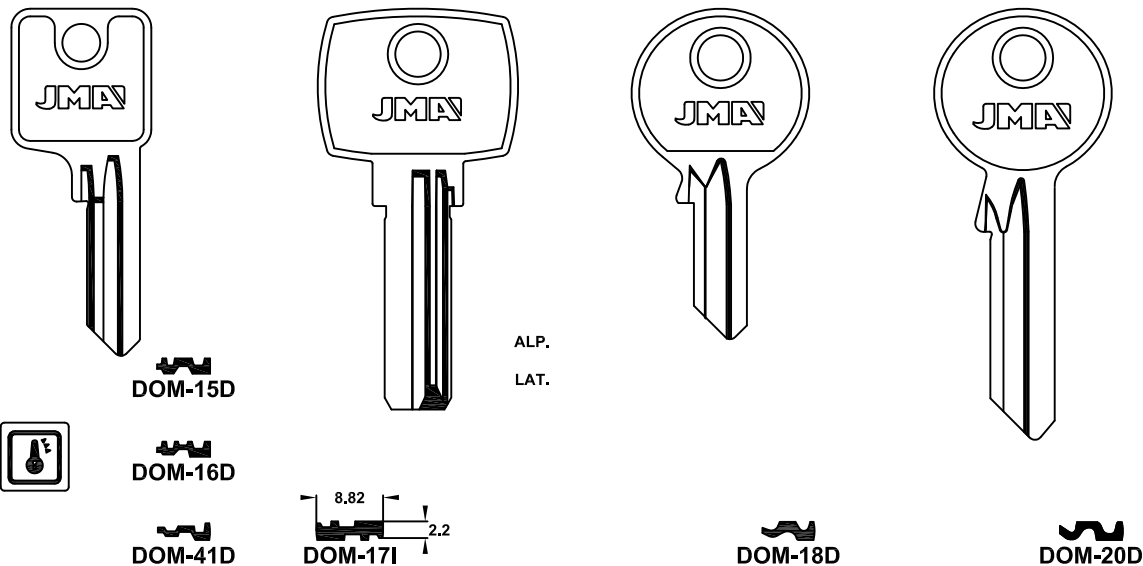

ALP.  
LAT.

CORBIN-EMHART

**DOM**

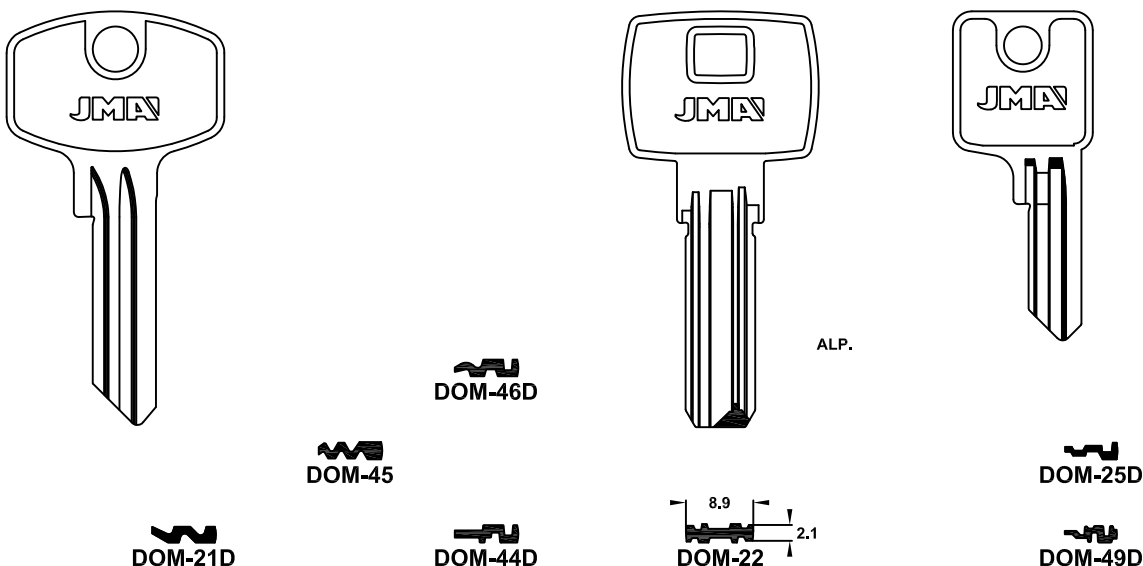

ALP.

CORBIN

ARCU

**DOM**

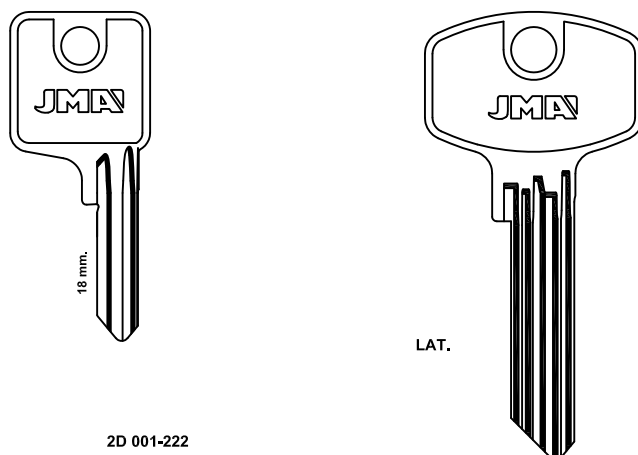

LAT.

2D 001-222  
5A 0001-2600  
9A 0001-5200  
1D 601-654

DOM-26    DOM-26D

DOM-27/35  
DOM-27/19  
DOM-27/16  
DOM-27/13  
DOM-27/12





# DOM

PARA-FOR:

DOM (D)

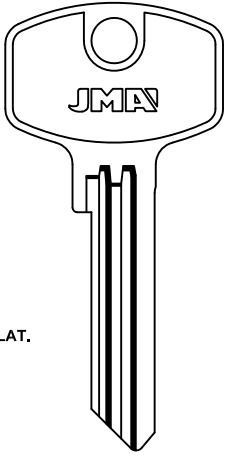

|           |            |            |            |            |
|-----------|------------|------------|------------|------------|
| DOM-27D/2 | DOM-27D/9  | DOM-27D/16 | DOM-27D/23 | DOM-27D/30 |
| DOM-27D/3 | DOM-27D/10 | DOM-27D/17 | DOM-27D/24 | DOM-27D/31 |
| DOM-27D/4 | DOM-27D/11 | DOM-27D/18 | DOM-27D/25 | DOM-27D/32 |
| DOM-27D/5 | DOM-27D/12 | DOM-27D/19 | DOM-27D/26 | DOM-27D/33 |
| DOM-27D/6 | DOM-27D/13 | DOM-27D/20 | DOM-27D/27 | DOM-27D/34 |
| DOM-27D/7 | DOM-27D/14 | DOM-27D/21 | DOM-27D/28 | DOM-27D/35 |
| DOM-27D/1 | DOM-27D/8  | DOM-27D/15 | DOM-27D/22 | DOM-27D/36 |

|            |            |            |            |
|------------|------------|------------|------------|
| DOM-27D/37 | DOM-27D/44 | DOM-27D/51 | DOM-27D/58 |
| DOM-27D/38 | DOM-27D/45 | DOM-27D/52 | DOM-27D/59 |
| DOM-27D/39 | DOM-27D/46 | DOM-27D/53 | DOM-27D/60 |
| DOM-27D/40 | DOM-27D/47 | DOM-27D/54 | DOM-27D/61 |
| DOM-27D/41 | DOM-27D/48 | DOM-27D/55 |            |
| DOM-27D/42 | DOM-27D/49 | DOM-27D/56 |            |
| DOM-27D/43 | DOM-27D/50 | DOM-27D/57 |            |

# DOM

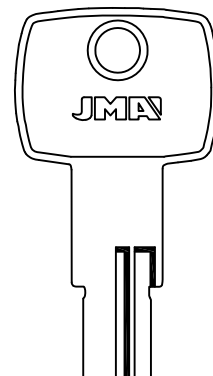
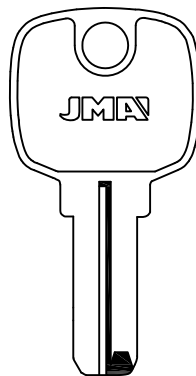
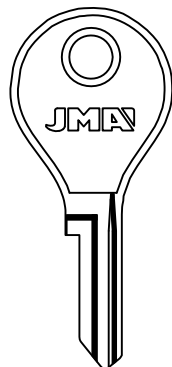
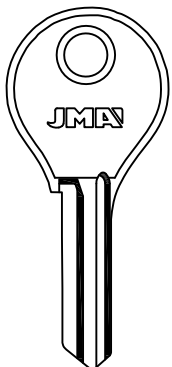

ALP.

LAT.

DOM-28 DOM-28D

6E...1-205  
 DOM-29

EA0

8.4  
 2.4  
 DOM-30

MOREAUX

8.9  
 IX 5  
 2.35  
 DOM-31

CORBIN-EMHART



PARA-FOR:

DOM (D)

DOM

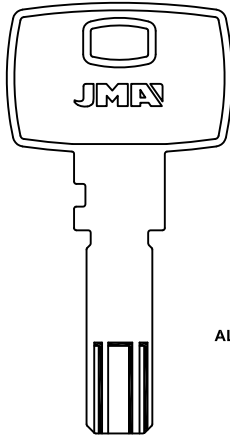

ALP.

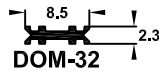

DOM-32

CORBIN-EMHART

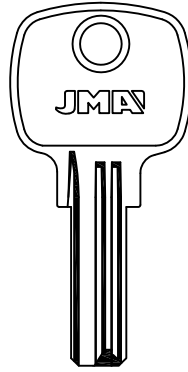

ALP.

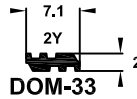

DOM-33

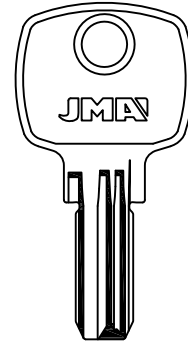

ALP.

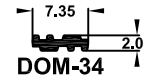

DOM-34

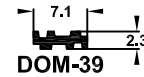

DOM-39

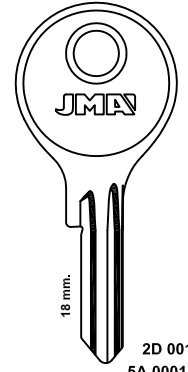

18 mm.



DOM-35



DOM-35D



DOM-51

2D 001-222  
5A 0001-2600  
9A 0001-5200  
1D 601-654

DOM

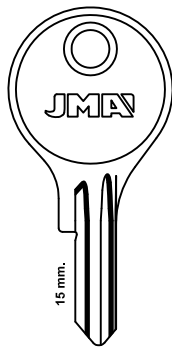

15 mm.



DOM-36

2D 001-222  
5A 0001-2600  
9A 0001-5200  
1D 601-654



DOM-36D

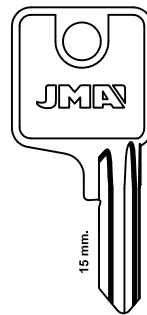

15 mm.



DOM-37

2D 001-222  
5A 0001-2600  
9A 0001-5200  
1D 601-654



DOM-37D

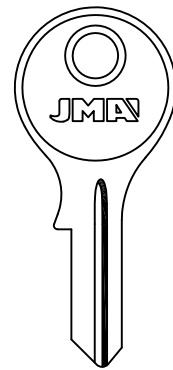

DOM-38D

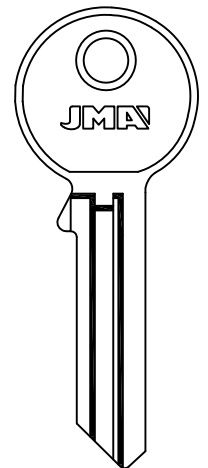

DOM-40D

DOM

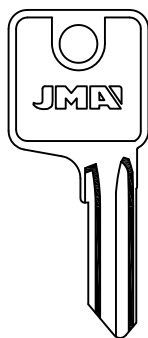

DOM-42  
FLAMBO-HEKNA-NOBO  
PEROHAUS

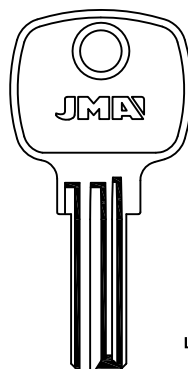

LAT.



DOM-43

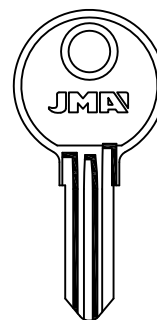

DOM-52

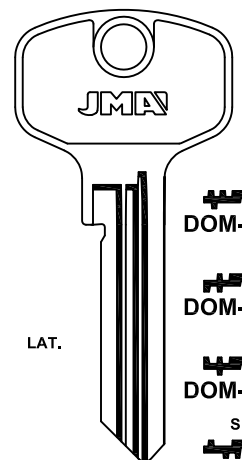

LAT.



DOM-74D



DOM-72D



DOM-58D



DOM-54D



DOM-53D



## DOM

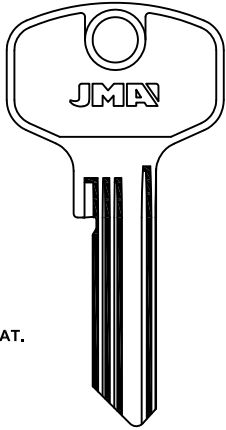

 DOM-73D

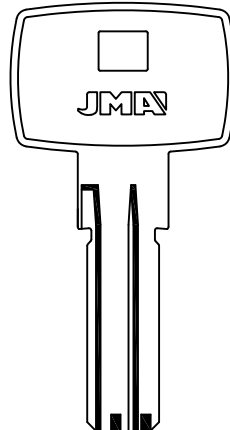

 DOM-71D

 DOM-65

 DOM-67D

 DOM-61

 DOM-60D

 DOM-59

 DOM-57

 DOM-57D

 DOM-55

 DOM-55D

 DOM-56D

 DOM-63D

 DOM-62D

STUV

LAT.

ALP.

## PARA-FOR:

DOM (D)

DOMINION LOCK (USA)

DOMUS (I)

## DOM

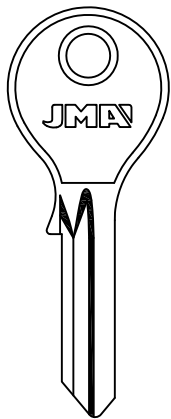

 DOM-64D

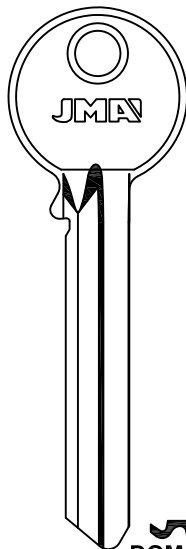

 DOM-66D

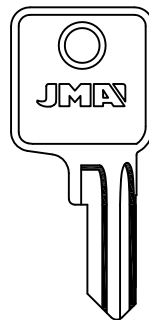

CL...1-250  
GP...1-250  
C...1001-1200  
C...1301-1500  
 DOM-68

GEWIRU

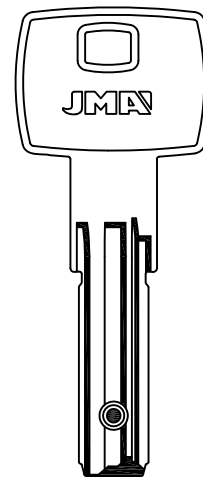

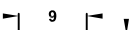
 DOM-B1

CORBIN-ST5

ALP.

## DOMINION LOCK

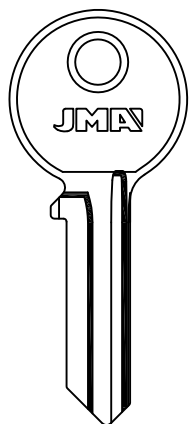

 DOI-1

PETERBORO

LAT.

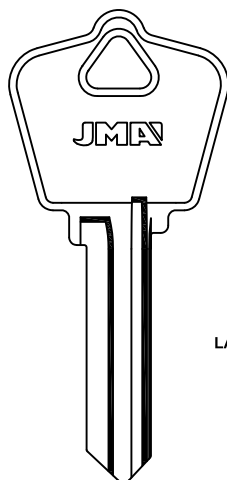

 DOI-4

LAT.

## DOMUS

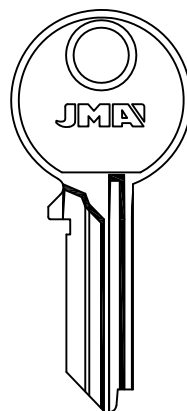

 DO-21

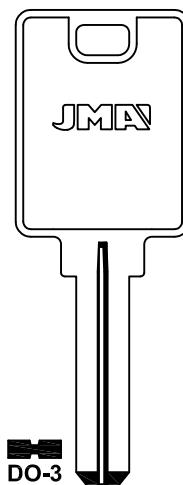

 DO-3











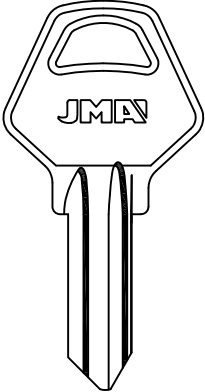
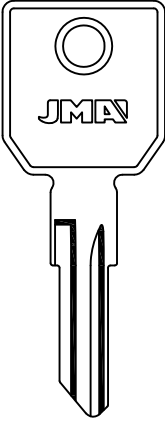
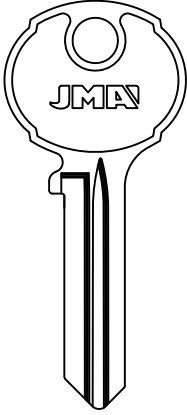
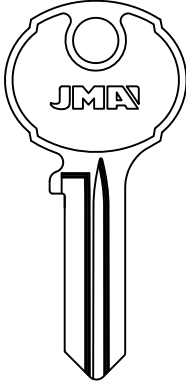





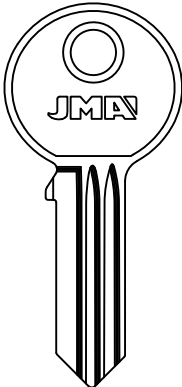

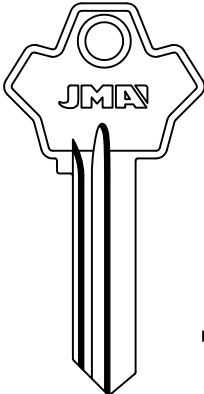
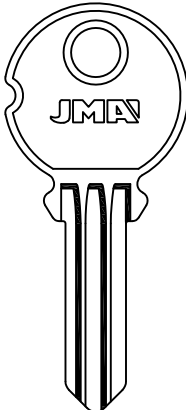
 DO-4

ALP.

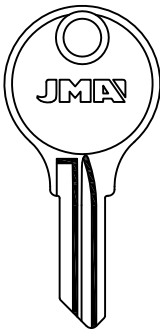
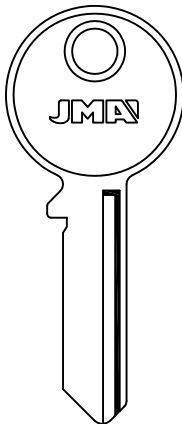
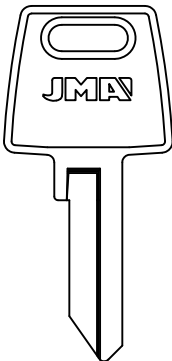
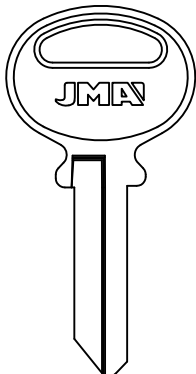

**PARA-FOR:**

- DOMUS (I)
- DOUBLE CIRCLE (RC)
- DURALOCK (USA)
- EAG (D)
- EAGLE (USA)
- ECM (I)
- EIKO (J)

| DOMUS  |   | DOUBLE CIRCLE  |   |
|--|---|--|---|
|           |          |            |          |
|  DO-5     |  DO-5D   |  DO-7       |  DC-1D   |
|  |   |  |  DC-2D   |
|  |   | TRI CIRCLE   |   |
| DOUBLE CIRCLE  |   | DURALOCK   | EAG   |
|          |         |           |         |
|  DC-3   |  DC-4D |  DUR-1D |  EG-2  |
|  |   |  |  EG-1  |
|  |   | LAT.   |   |
| EAGLE  | ECM   | EIKO   |   |
|         |        |         |        |
|  EAG-2D |  EC-1  |  EI-1D  |  EI-2D |
| EZ...<br>PZ...<br>1-240  |   |  | CINA  |
| LAT.   |   |  |   |



**ELZETT**



ELZ-10

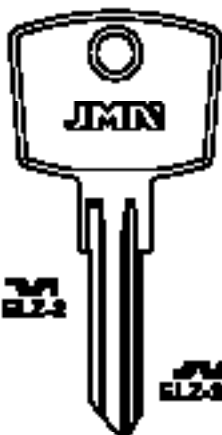

ELZ-4

ELZ-80

ELZ-40

ELZ-80



ELZ-80



ELZ-80

TIPENTAL-TUB

**ELZETT**

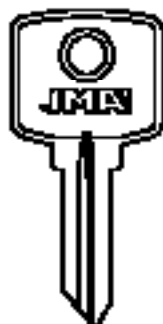

ELZ-4



LAT.

ELZ-10  
ELZ-110



ELZ-110

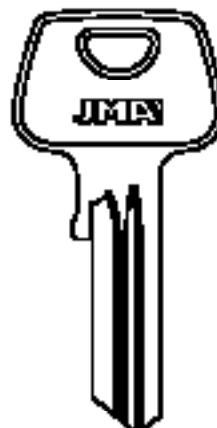

ELZ-12

ELZ-120

**EMKA**



EMK-1

**EP PINSON**



EP-10

**ERA**



ER-10



ER-20

**PARA-FOR:**

ELZETT (H)

EMKA (F)











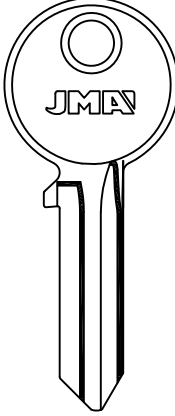
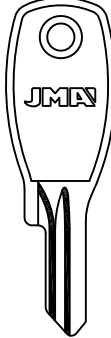
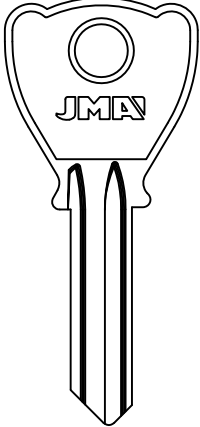
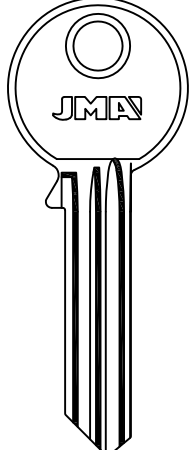





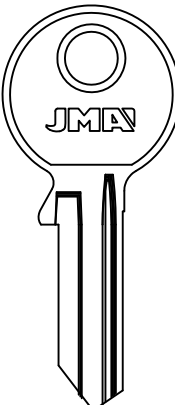
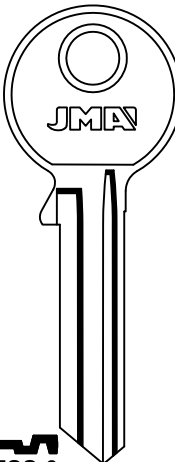
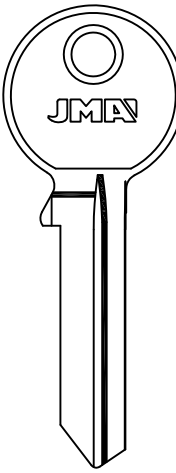
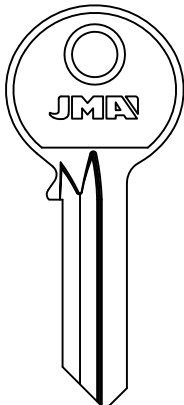

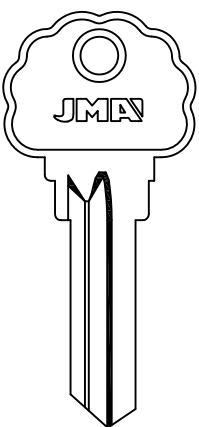
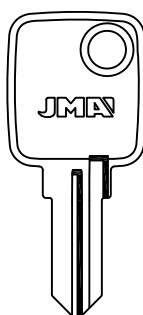
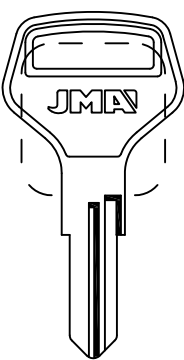
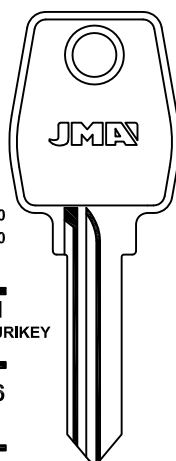

EP PINSON (GB)

ERA (GB)



**PARA-FOR:**

- ERA (GB)
- ESA (E)
- ESLA (GB)
- ESS (D)
- ETAS (GB)
- EUREKA (I)
- EURO BOX
- EURO LOCKS (B)

| ERA   |   | ESA   |   | ESLA  |   |
|---|---|---|---|---|---|
|    |    |     |   |    |   |
|    |    |     |  |    |    |
|   |   | NUMIDA  |   |   |   |
| ESS   |   |   | ETAS  |   |   |
|   |   |    |   |   |   |
|  |  |   |   |   |   |
|  |  |  |   |  |   |
|   |   | BAB   |   | YANEDIS   |   |
| EUREKA  |   | EURO BOX  |   | EURO LOCKS  |   |
|  |  |   |   |  |   |
|  |  |  |   |  |   |
|   |   | BRABANTIA-MARS-WEDO   |   | 47001-48000<br>45000-47000<br>1201-1400<br>EMKA-SECURIKEY                             |   |
|   |   |   |   |  |   |
|   |   |   |   |  |   |
|   |   |   |   |  |  |



## EURO LOCKS

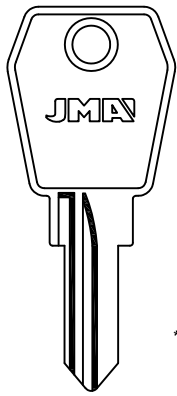

\* ALU.



25001-27000



FASMA-L.&F.

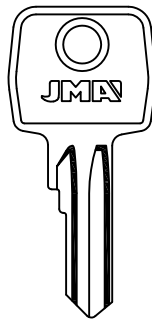
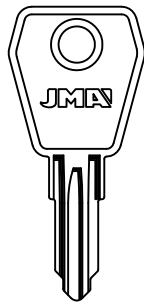

....  
....A  
458-5124



....  
....E  
405-4324

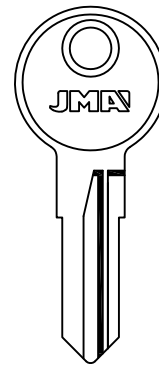

EU-7



EU-7D



EU-11

## PARA-FOR:

EURO LOCKS

(B)

EVERGOOD (RC)

EVVA (A)

## EURO LOCKS

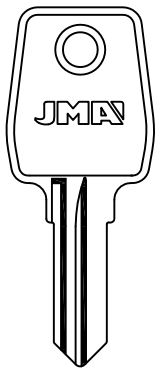

L&F

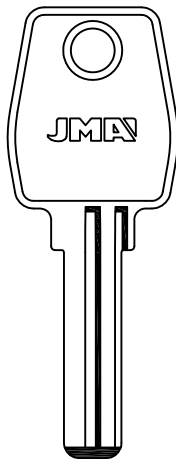

LAT.

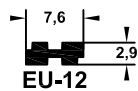

HOBBY-HYMER

## EVERGOOD

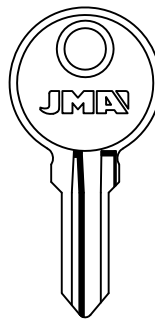

ARREGUI

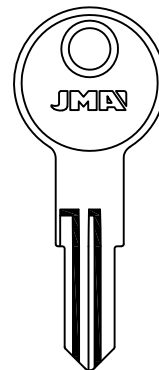

## EVERGOOD

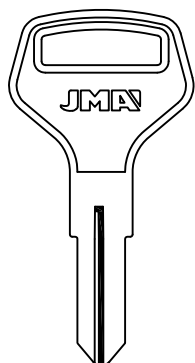

EVE-3D

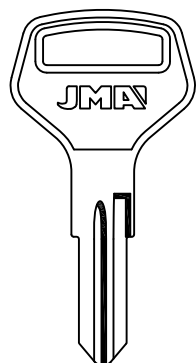

EVE-4

## EVVA

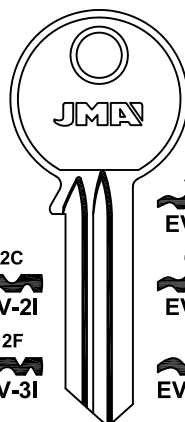

\* LAT.



EV-2I



EV-3I



EV-1



EV-2



EV-3D



EV-13D



EV-25D

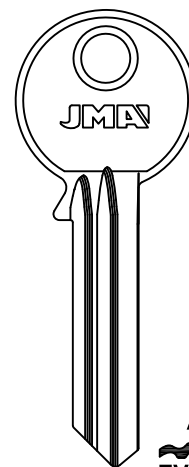

EV-4D



EV-10

ELCA

**JMA**<sup>®</sup>

Copyright by Alejandro Altuna S.A. 2014



ATENCIÓN: Concerniente a las marcas y denominaciones comerciales ver nota en índice.

ATTENTION: Concerning the marks and commercial denominations see note in index.

ATTENTION: Concernant les marques et dénominations commerciales voir la note dans l'index.

ACHTUNG: Beziehen auf die marke und handelsname sehen sie die notiz im index.

**PARA-FOR:**

EVVA (A)

EXCEL (F)

EXPRES (PL)

EZCURRA (E)

**EVVA**

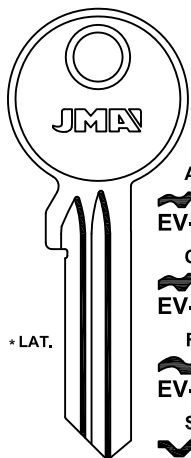

\* LAT.

- A  
EV-6D \* EV-27D/5 \* EV-27D/10
- C  
EV-7D \* EV-27D/4 \* EV-27D/9
- F  
EV-8D \* EV-27D/3 \* EV-27D/8
- S  
EV-9D \* EV-27D/2 \* EV-27D/7
- EV-23D \* EV-27D/1 \* EV-27D/6

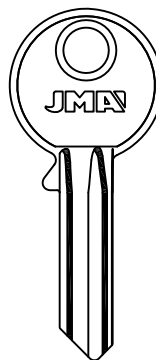

K0  
...101-1479



K1  
...2001-2479

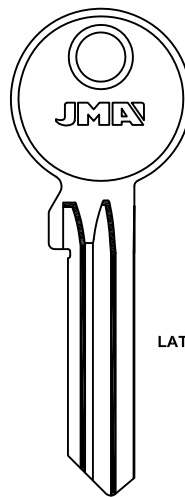

LAT.

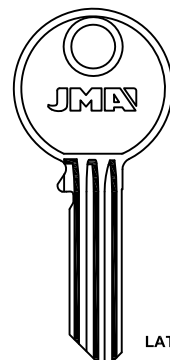

LAT.

NM...  
50000-54999



NM...  
65000-69999



ELCA-TRYBA

**EVVA**

**EXCEL**

**EXPRES**

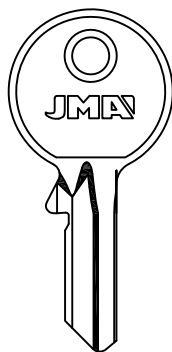

LAT.

...(K1) 4001-4250

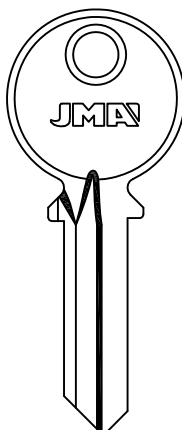

SIDLEEN

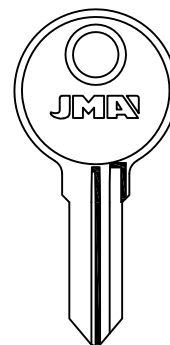
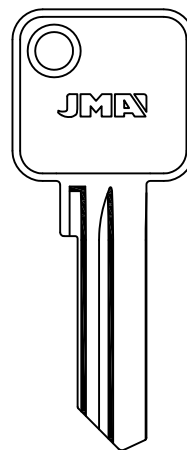

RST  
EXS-2D

WT  
EXS-3

WTR  
EXS-3D

**EXPRES**

**EZCURRA**

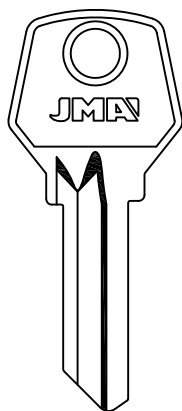

SISO

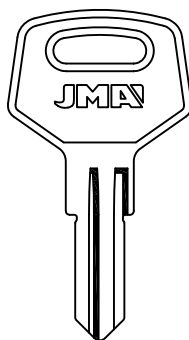

EXS-5 EXS-5D



SISO

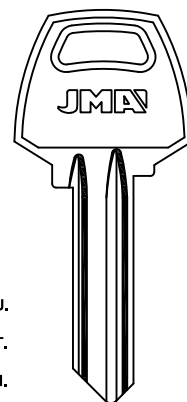

\* ALU.  
\* LAT.  
\* FSH.

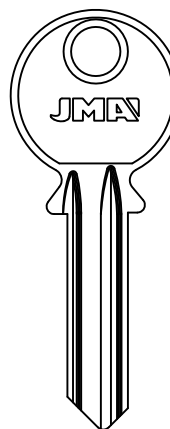



## EZCURRA

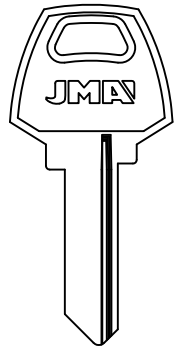

EZ-3I

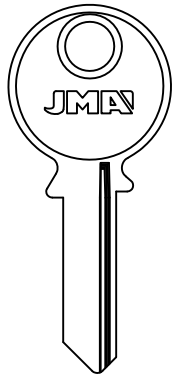

EZ-3D

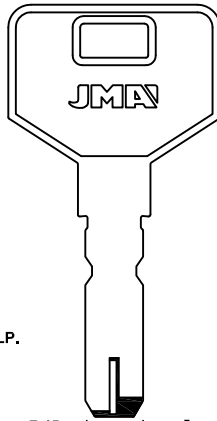

EZ-4I

EZ-4D

ALP.



EZ-DS10E

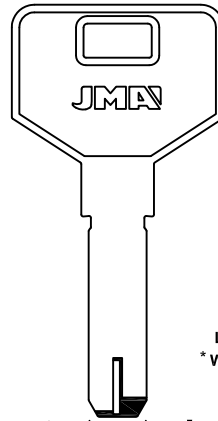

LAT.  
\* WNC.



\* EZ-DS15R

## PARA-FOR:

EZCURRA (E)

FAB (CZ)

## FAB

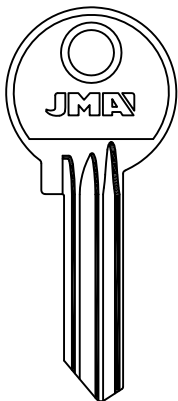

11  
FB-1



9  
FB-19



12  
FB-21



14  
FB-23



16  
FB-25

FB-31

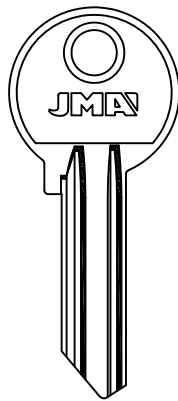

22  
FB-21

FB-2D



10X  
FB-4



11X  
FB-5

20  
FB-6

21  
FB-7

23  
FB-8



24  
FB-9



26  
FB-10



30  
FB-11

32  
FB-12

12X  
FB-26

14X  
FB-29

## FAB

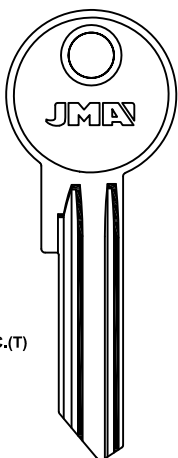

PR22  
\* FB-13



PR23  
FB-14

PR24  
FB-15

PR26  
FB-16



PR30  
\* FB-17

PR32  
FB-18

PR20  
\* FB-27

PR21  
FB-28



10X  
FB-32

12X  
FB-34

11X  
FB-35

K  
FB-38

14X  
FB-41

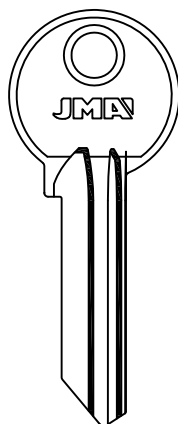

FB-33

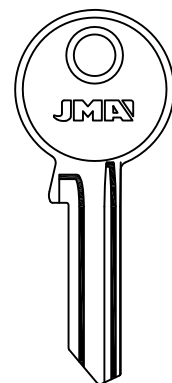

FB-39

\* MTIC.(T)



PARA-FOR:

FAC (E)

FAC

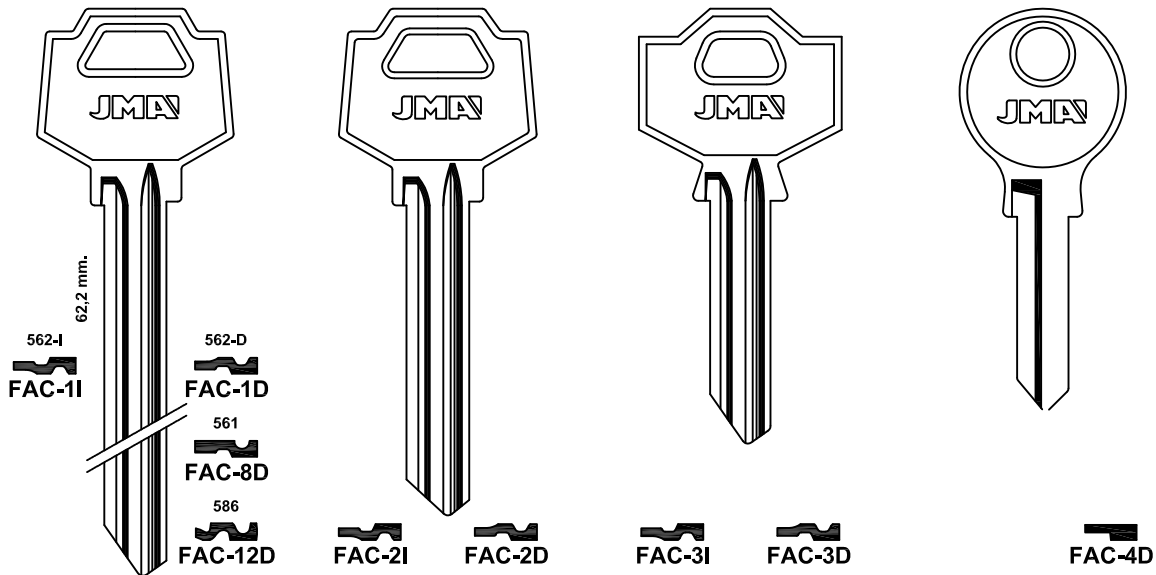

FAC

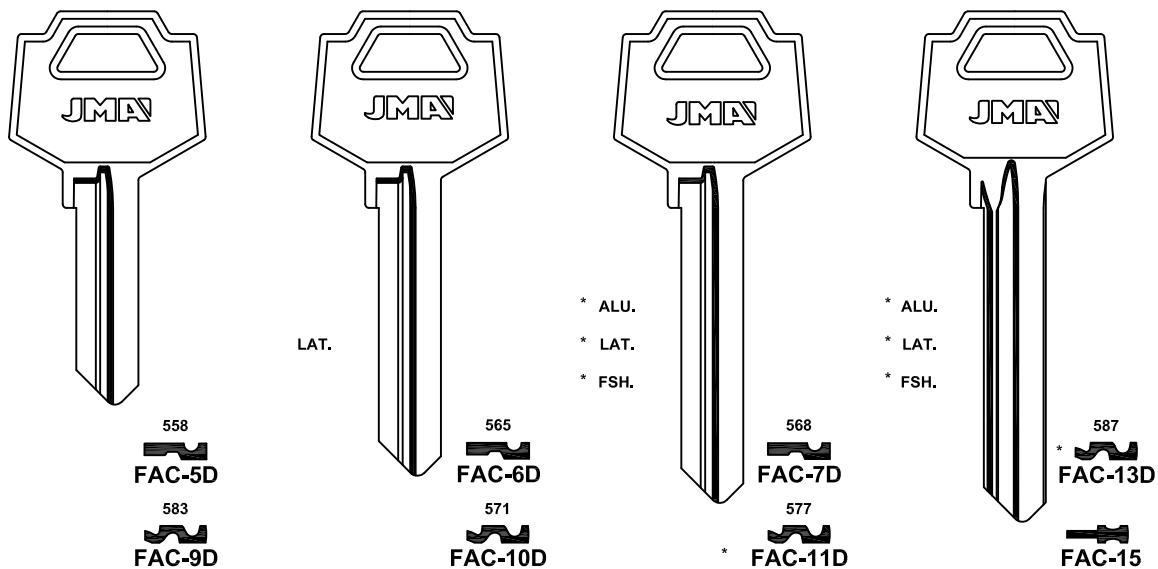

FAC

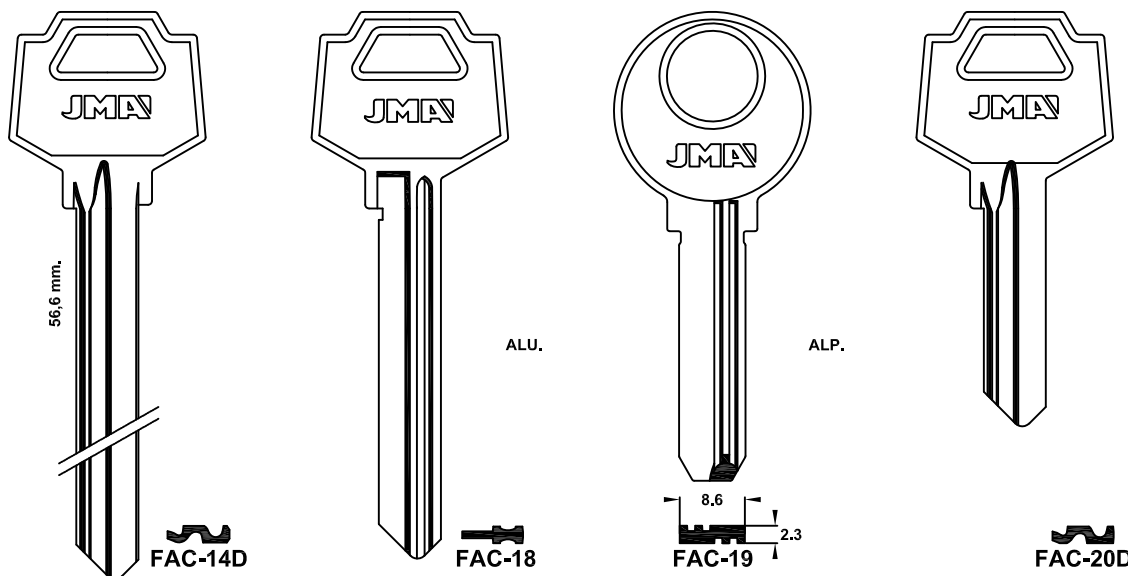

**FAC**

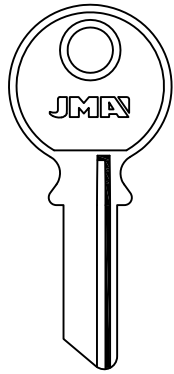

FAC-21

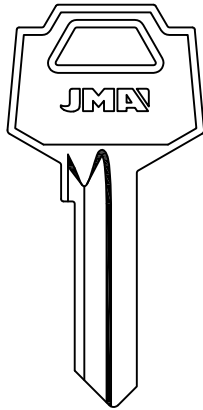

FAC-21D

FAC-22D

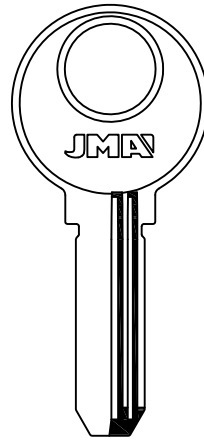

LAT.

FAC-23  
8.9 2.35

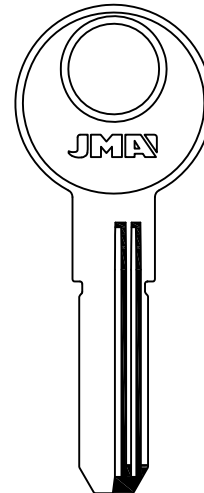

LAT.

FAC-24  
8.9 2.35

**PARA-FOR:**

- FAC (E)
- FAINER (P)
- FALCON (USA)
- FAMA (BR)
- FANA (D)
- FAS (S)
- FASEM (I)
- FAVOUR (DZ)

**FAINER**

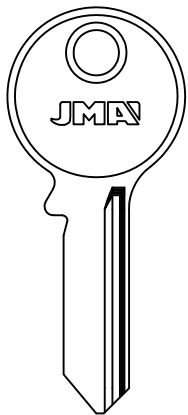

FAIN-1

SIL

**FALCON**

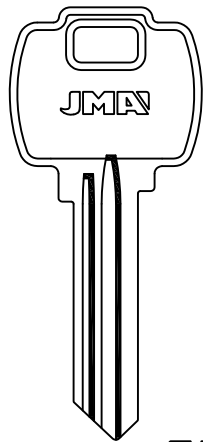

LAT.

FAL-1D

FAL-2D

WEISER

**FAMA**

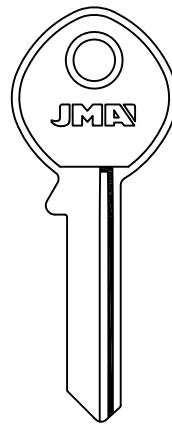

FAM-1

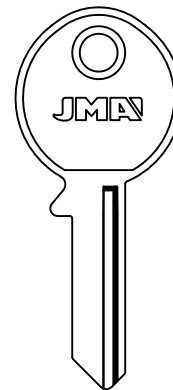

FAM-2

**FANA**

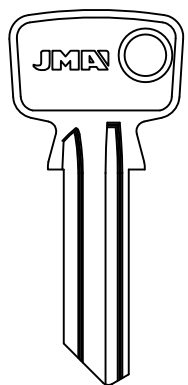

FAN-1

FAN-1D

**FAS**

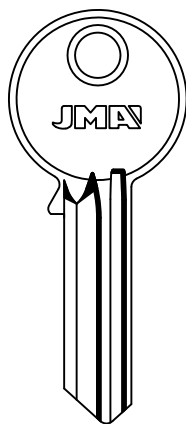

FA-1

FA-1D

**FASEM**

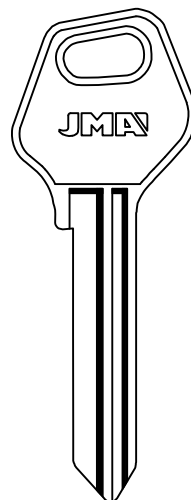

FAS-1

**FAVOUR**

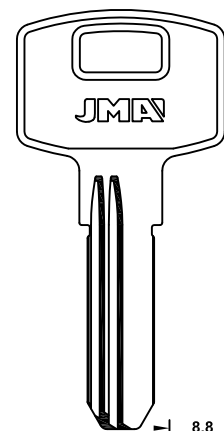

LAT.

FAV-1D  
8,8 2,35

FAV-2

TEICOCIL



**PARA-FOR:**

FAYN (RC)











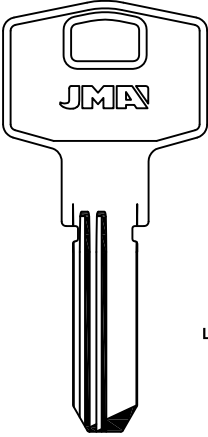
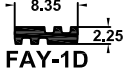
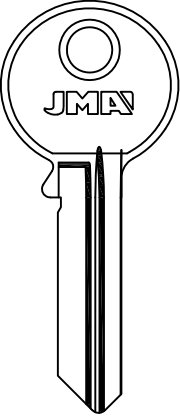

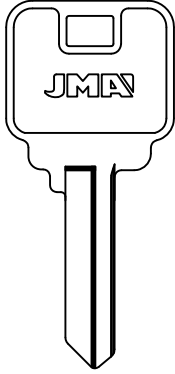

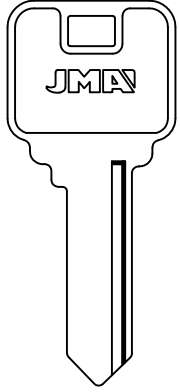

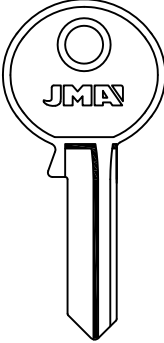

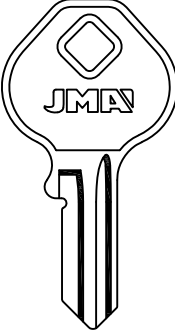

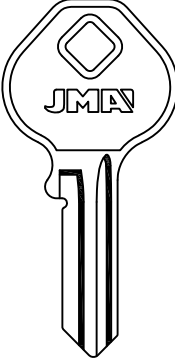

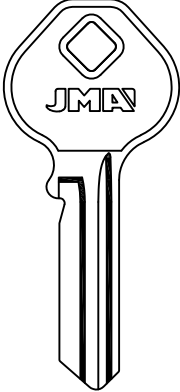

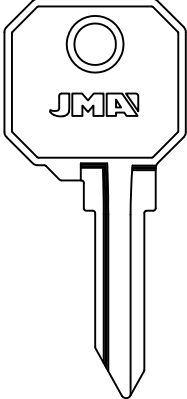

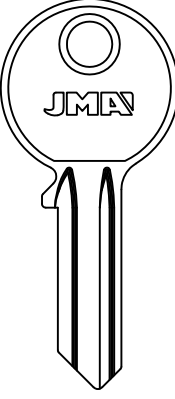
FCV (D)

FECHADURA  
(BR)

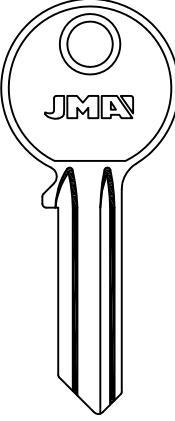
FEDERAL (USA)

FERONERIA  
(RU)

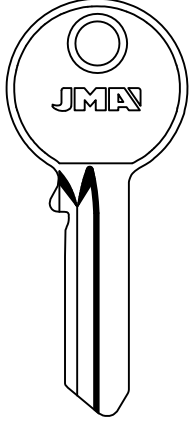
F.F. (I)

|  | FAYN  | FCV   | FECHADURA  |   |
|--|---|---|--|---|
|  |  <p>LAT.</p>  <p>FAY-1D</p> |   <p>FV-1D</p>  |   <p>FEC-1D</p>  |   <p>FEC-2<br/>STAM</p> |
|  | FECHADURA   | FEDERAL   |  |   |
|  |   <p>FEC-3D<br/>STAM</p> |   <p>FED-1</p>   |   <p>FED-2</p>  |   <p>FED-3</p>       |
|  | FERONERIA   | F.F.  |  |   |
|  |   <p>FER-1</p>          |  <p>0 AL 7</p>   <p>FF-1 FF-1D</p>  <p>FF-3</p> <p>GUARDIAN</p> |  <p>0 AL 7</p>   <p>FF-2 FF-2D</p>  <p>FF-10D</p> <p>GUARDIAN</p> |   <p>FF-5D</p>      |



F.F.

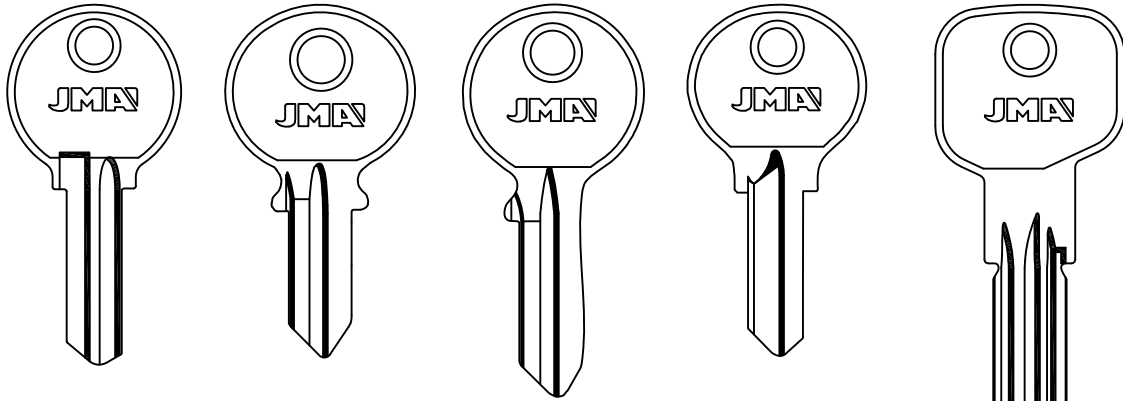

FF-6



FF-11



FF-7D



FF-8D



FF-9D



FF-13

LAT.

PARA-FOR:

F.F. (I)

FIC LOCKS  
(USA)

FICHET (F)

FIC LOCKS

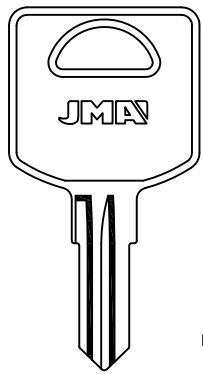

LAT.



FCS-1D

FICHET

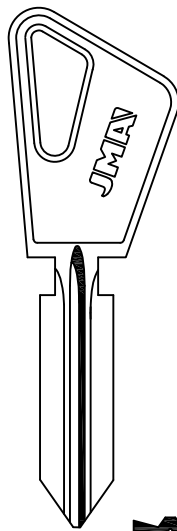

LAT.



FIC-1



FIC-2

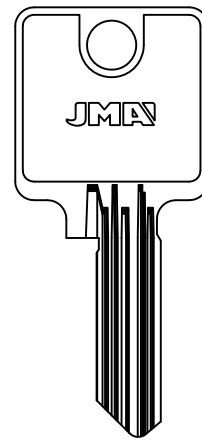
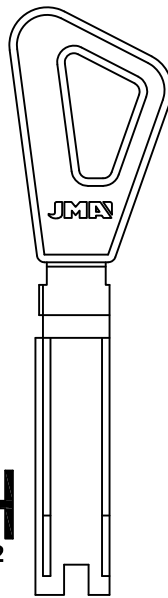

FIC-5

SURFINOR

FICHET

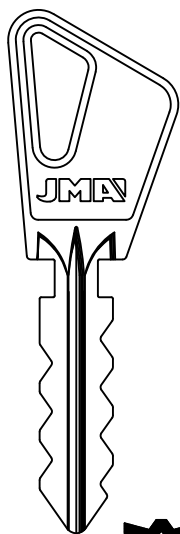

FIC-7

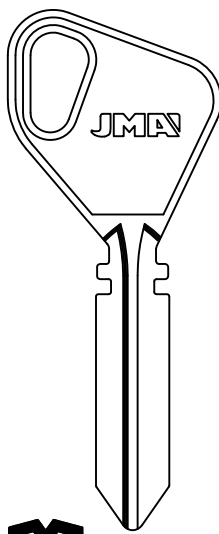

FIC-8

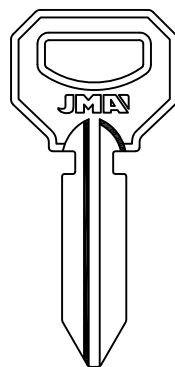

FIC-9

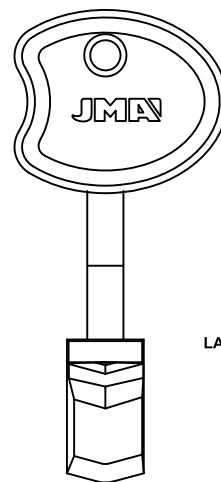

FIC-18

LAT.











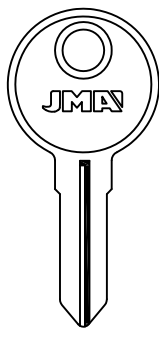

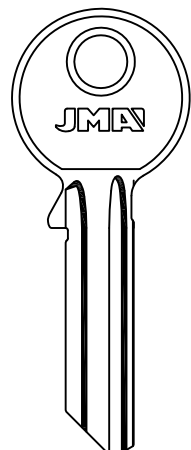

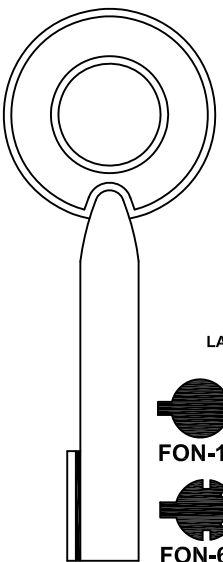

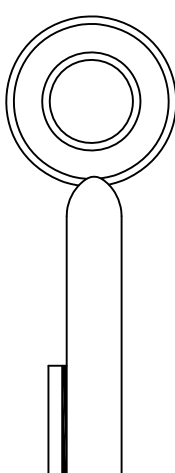
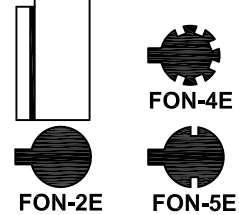
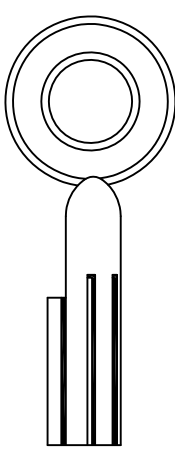

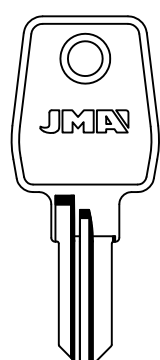
SURFINOR

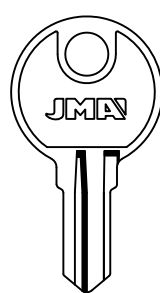
TECNOR

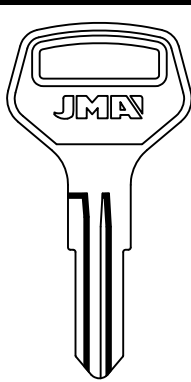
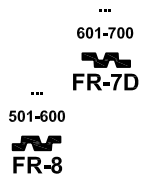
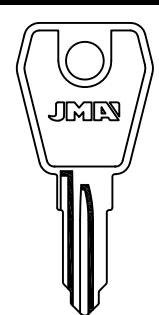

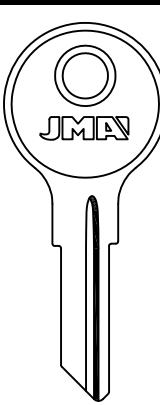
**PARA-FOR:**

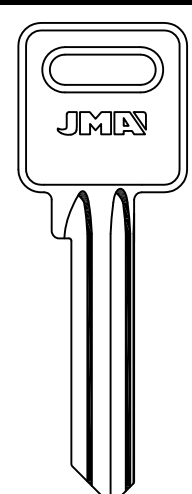
- FIST (I)
- FLORA (D)
- FONTAINE (F)
- FORT (F)
- FORTE (YV)

| FIST   | FLORA  | FONTAINE  |   |
|--|--|---|---|
| <br><br><b>FIS-1D</b>  | <br><br><b>FLO-1 FLO-1D</b><br><small>FLOHR-NB-NORDWEST-SUKI</small> | <br><br><b>FON-1E FON-6E</b><br><small>LAT.</small> |   |
| FONTAINE   |  | FORT  |   |
| <br><br><b>FON-2E FON-4E FON-5E</b><br><small>PROGRES</small> | <br><br><b>FON-3E</b><br><small>LAT.</small>                      | <br><br><b>FR-1D</b><br><small>DAD</small>       | <br><br><b>FR-4</b>          |
| FORT   |  |   | FORTE   |
| <br><br><b>FR-7D FR-8</b><br><small>ARREGUI</small>          | <br><br><b>FR-9D</b><br><small>ABUS-SECURITAL</small>            | <br><br><b>FR-11D</b>                           | <br><br><b>FTE-1 FTE-1D</b> |

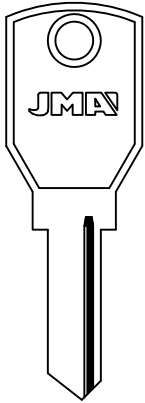
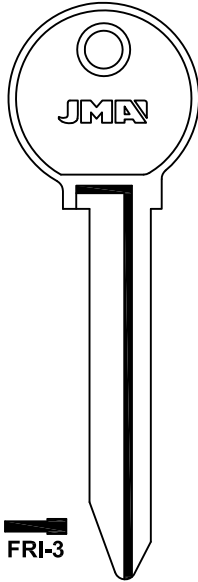
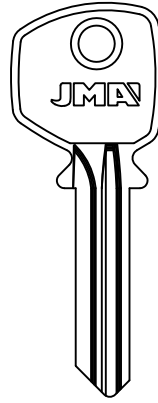
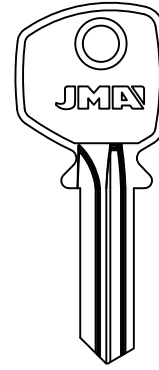

**FORTIS**  
FORTIS-21**FRIPA**  
FRI-3**FTH**  
FTH-1  
FTH-8  
FTH-1D  
FTH-8D  
FTH-2**PARA-FOR:**

FORTIS (E)

FRIPA (D)

FTH (F)

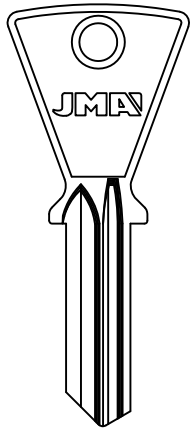
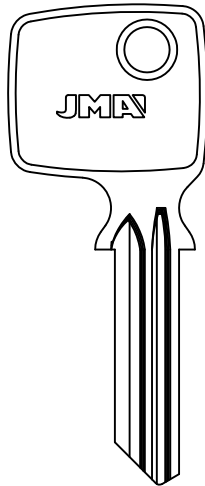
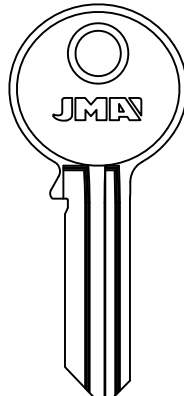
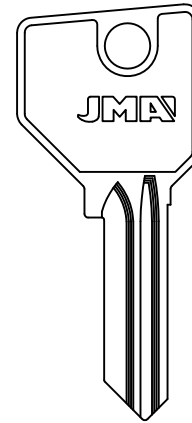
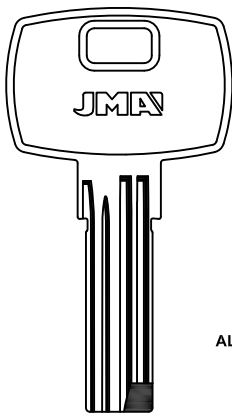
**FTH**  
FTH-3  
FTH-4.....A 1 AL 9  
  
FTH-5  
FTH-22  
FTH-6**FTH**

ALP.

  
FTH-7

CODEM-TOVER-YALTRES

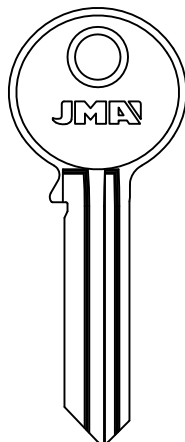
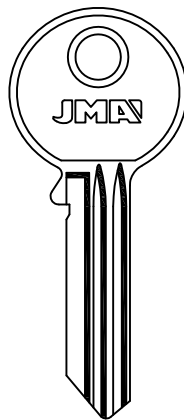
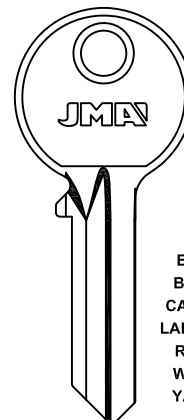
.....A 1 AL 9  
  
FTH-9  
FTH-10  
FTH-21CF-CIB-4FAM-JL-NICO-PROBAT  
CIBC-CITY-SUF

.....0 AL 9

  
FTH-11DBKS  
BIRD  
CARAT  
LAREDO  
ROC  
WOC  
YALE

PARA-FOR:

FTH (F)

FTH

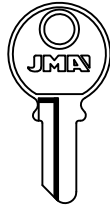

FTH-12D

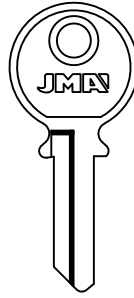

FTH-13D

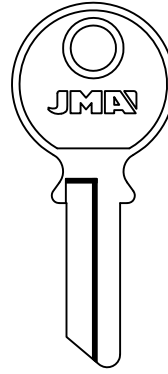

FTH-14D

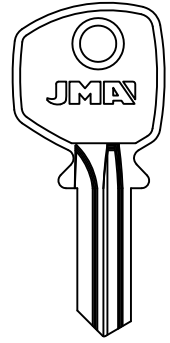

FTH-15

FTH

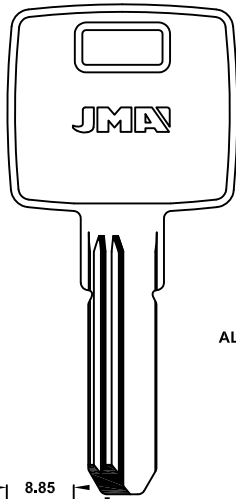

FTH-16  
8.85  
2.95

IFAM-KARO

ALP.

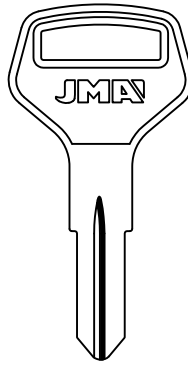

FTH-17D

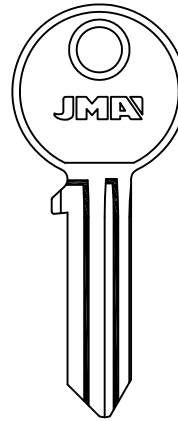

FTH-18  
.....A 1 AL 9

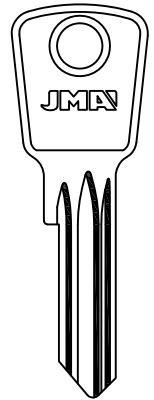

FTH-19

FEDERAL

FTH

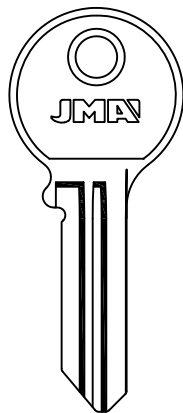

FTH-20D

HERACLES

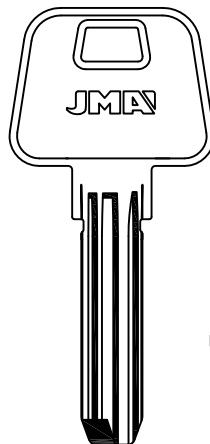

FTH-23  
7.9  
2.95

ATLANTIC

LAT.

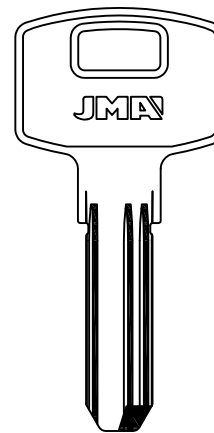

FTH-25  
8.5  
2.35

SP

LAT.

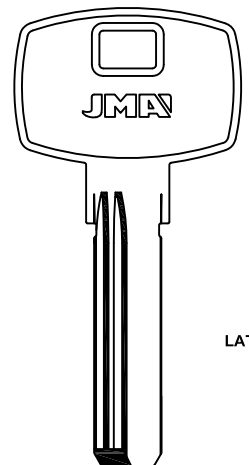

FTH-26D  
8.7  
2.35

SP

LAT.





**FTH**

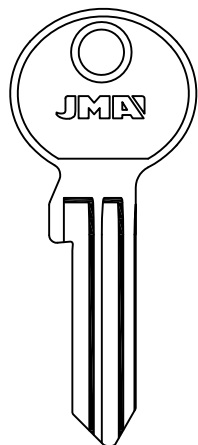

FTH-27

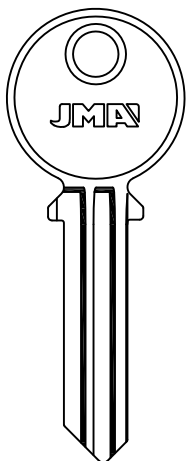

FTH-28

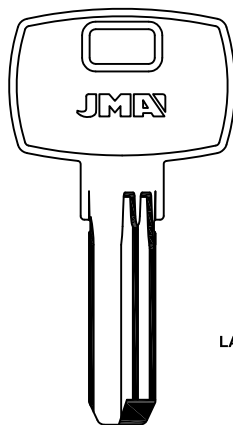

LAT.

FTH-29  
8,65  
2,8

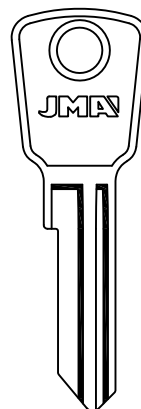

FTH-31

FEDERAL

**PARA-FOR:**

- FTH (F)
- GABON (F)
- GAMMET (PL)
- GATO (COL)
- GBZ (I)
- GE GE (A)

**GABON**

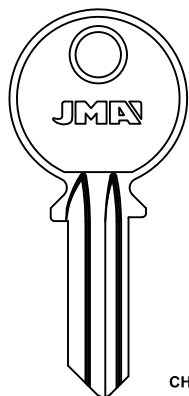

GAB-1I

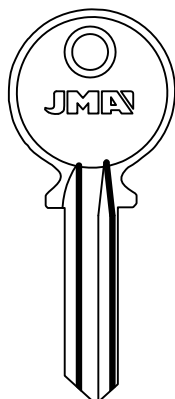

GAB-2  
CHG-GALLUS-MAXIGARD  
PICARDIE-SOS-WINNER

GAB-1D

CHG  
GALLUS  
MAXIGARD  
PICARDIE  
SOS  
WINNER

**GAMMET**

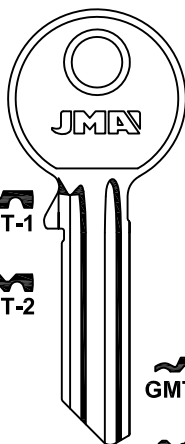

GMT-1

GMT-2

GMT-3D

GMT-4D

GMT-5D

EXPRES

**GATO**

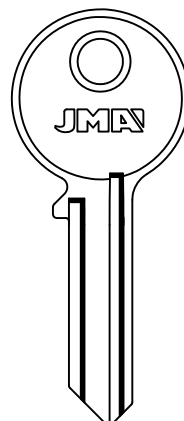

GAT-1

**GATO**

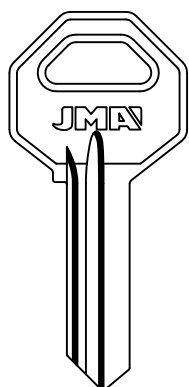

LAT.

GAT-2D

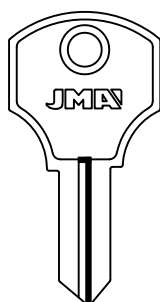

LAT.

GAT-3D

**GBZ**

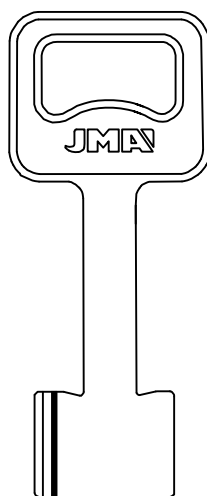

LAT.

GBZ-1

**GE GE**

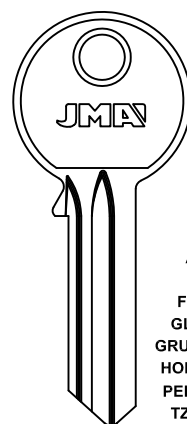

ABUS  
FLIK  
FULLEX  
GLOSTAL  
GRUNDMANN  
HOHRMANN  
PEROHAUS  
TZAFRER

GE-1D

GE-2



**PARA-FOR:**

GE GE (A)

GEBA (D)

GERA (D)

**GE GE**

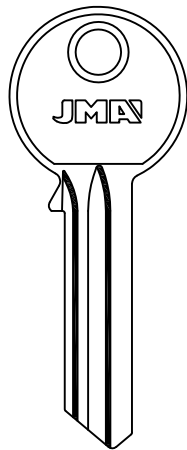

1.....  
500001-735807



ALFA-FINSTRAL

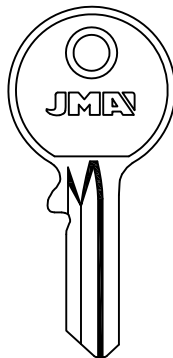

X....1001-1875  
E...00-576



LABOFA-PEROHAUS

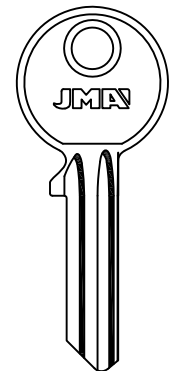
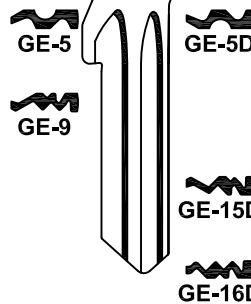
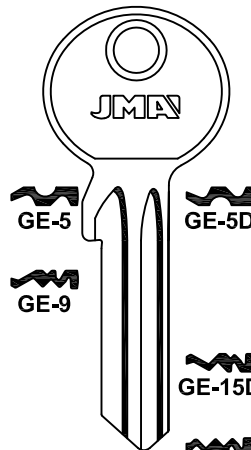

PEROHAUS

**GE GE**

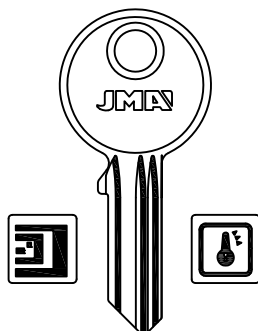

M35 Z....  
20655-21806



M25 Z....  
9135-10286

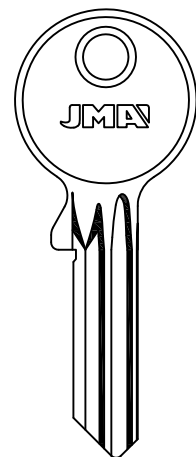
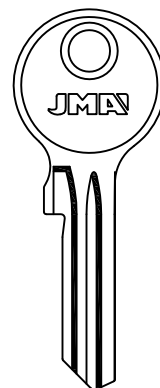
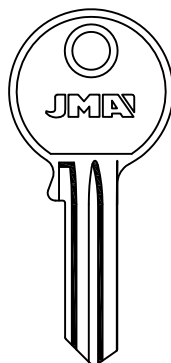

**GEBA**

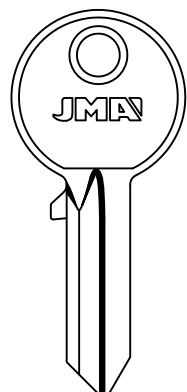

GEB-1D

**GERA**

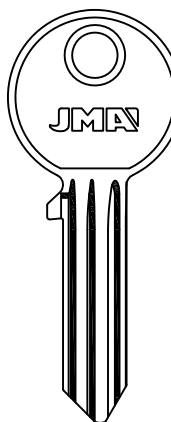

GEA-1

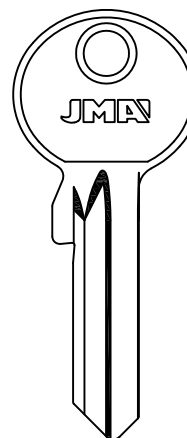

GEA-2D

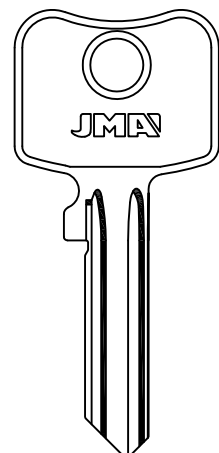

GEA-3



## GERA

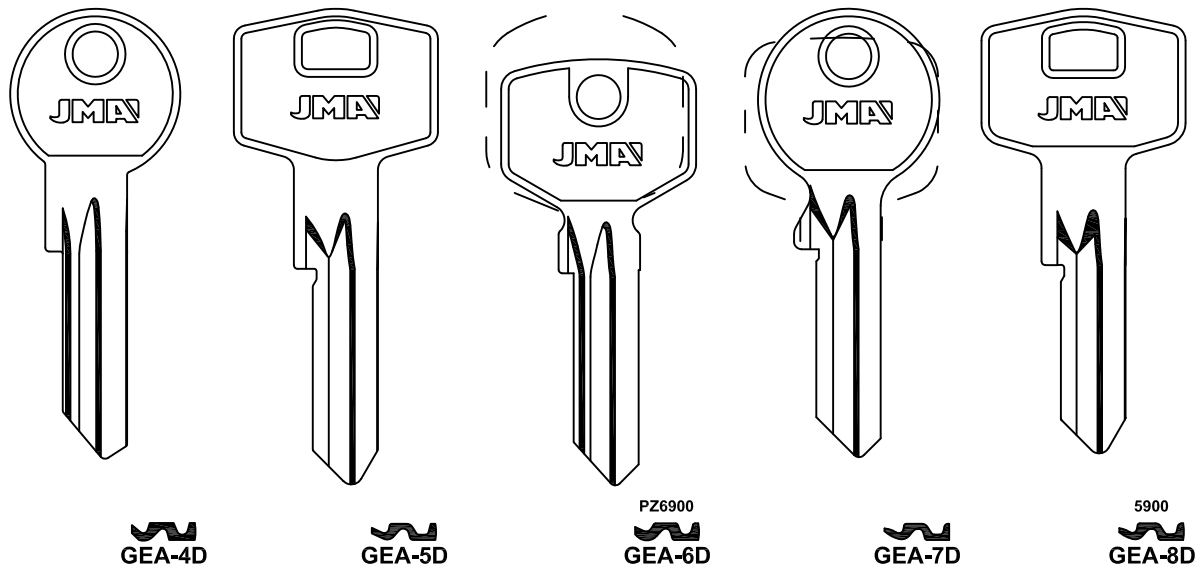

ROTO

## PARA-FOR:

- GERA (D)
- GERDA (PL)
- GIBBONS (GB)
- GIUSSANI (I)

## GERDA

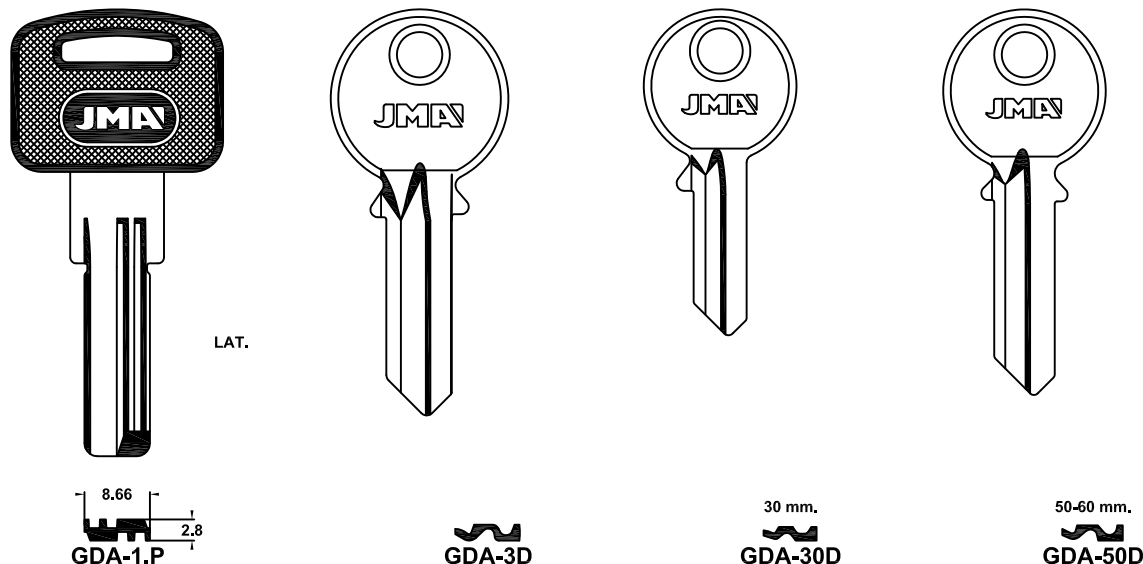

EUROPROFIL

EUROPROFIL

### GERDA

### GIBBONS

### GIUSSANI

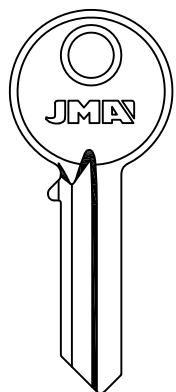

GDA-60D

EUROPROFIL

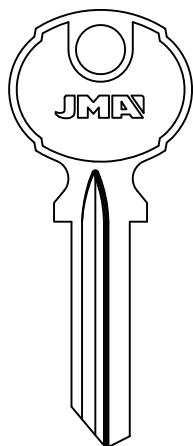

GIB-1D

WILLENHALL

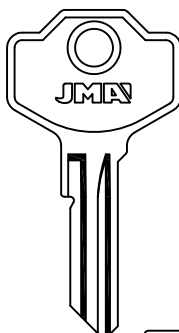

9001-9741  
3001-3480

GIU-1

3001-3480

GIU-2

SIMECA



GIU-1D

GIU-2D

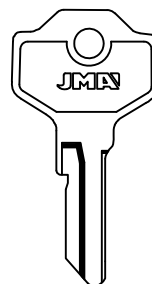







GIU-3D

OAL-LUME

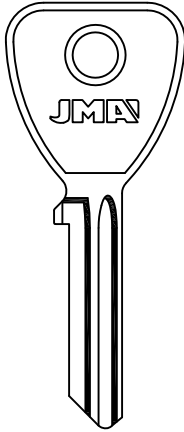
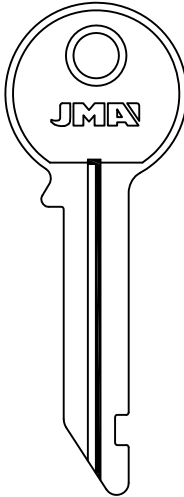
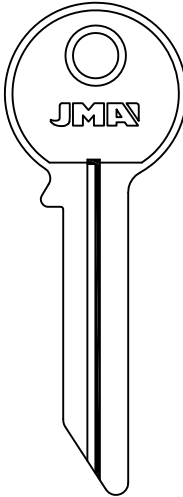
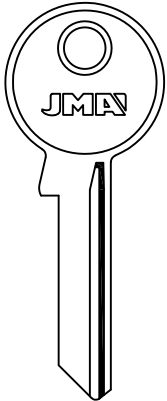







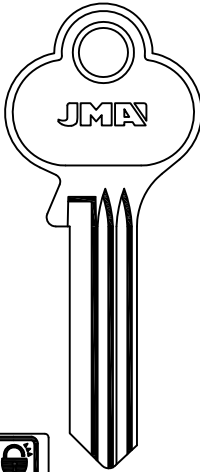
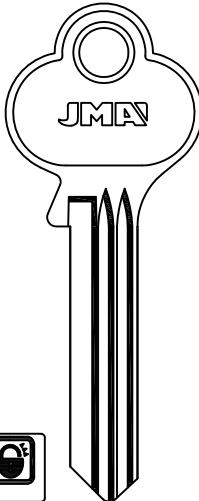
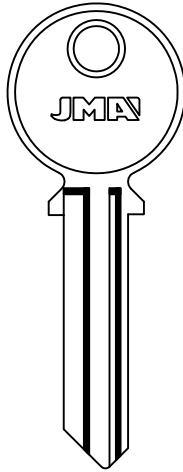
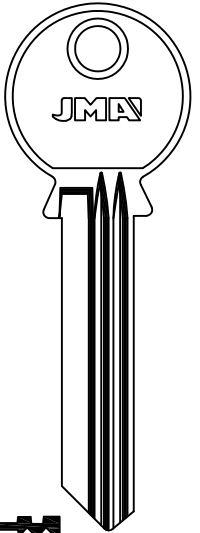

**PARA-FOR:**







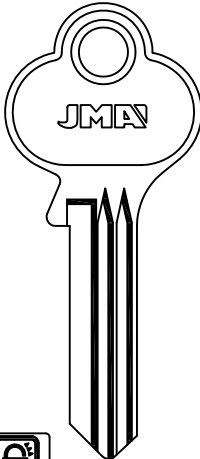
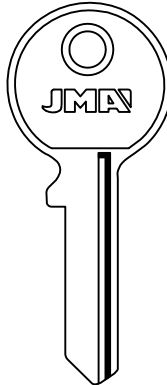
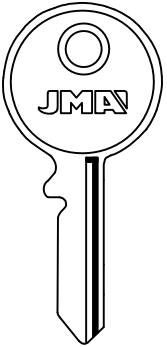
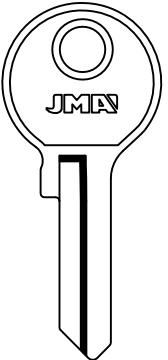

- GIUSSANI (I)
- GLAZIEV (RUS)
- GLOBE (RC)

| GIUSSANI  | GLAZIEV   |   | GLOBE   |
|---|---|---|---|
|  |  |   |    |
|  |  |  |   |

**GLOBE**

|   |   |  |   |
|---|---|--|---|
|   |   |   |   |
|   |   |   |  |
| LARK  |   | MIAN-FORCE   |   |

**GLOBE**

|   |   |  |   |
|---|---|--|---|
|    |    |   |  |
|   |   |   |  |
| GOLD DOOR   |   |  |   |



# GLOBE

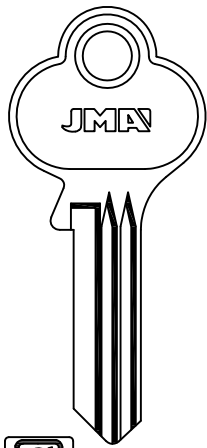

GLO-10

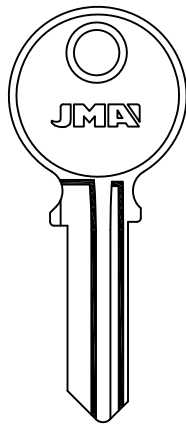

GLO-11

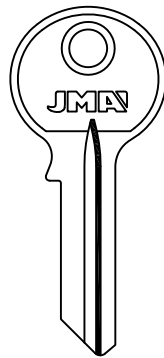

GLO-12D

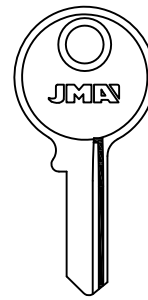

GLO-22 GLO-22D

GOLD DOOR

# PARA-FOR:

- GLOBE (RC)
- GODREJ (IND)
- GR (RC)
- GTV (D)
- GUARD (HK)

## GLOBE

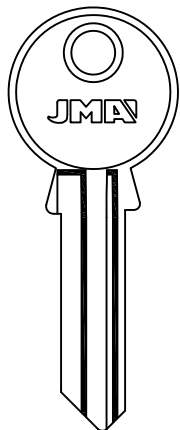

GLO-23 GLO-23D

ANLO-LUCO

## GODREJ

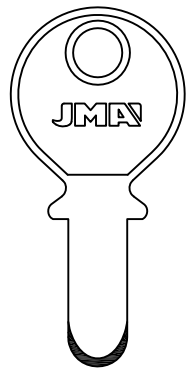

ALP.



GOD-1

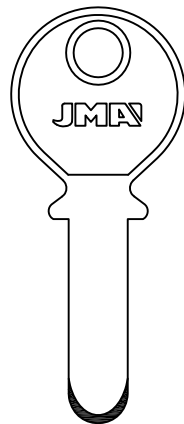

ALP.

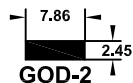

GOD-2

## GR

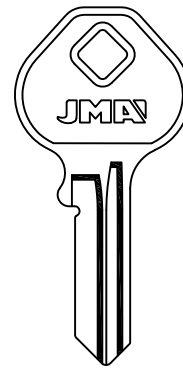

GRG-1

## GTV

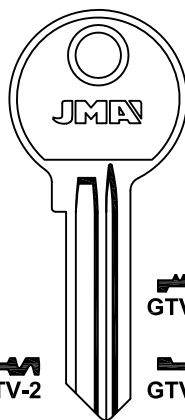

GTV-1D

GTV-2

GTV-2D

GTV-3D

GTV-4D

TIEFENTHAL

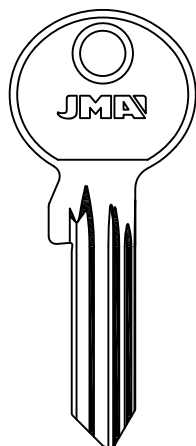

GTV-5D

JOWIL-TIEFENTHAL

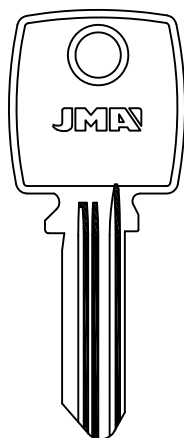

GTV-11

GTV-10

TIEFENTHAL

LAT.

## GUARD

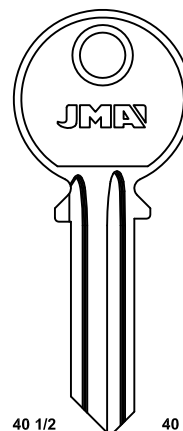

40 1/2  
GUA-1

41 1/2  
GUA-2

40  
GUA-1D











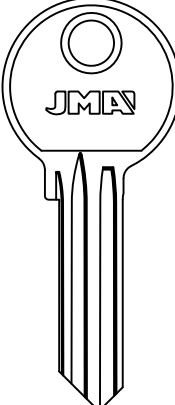
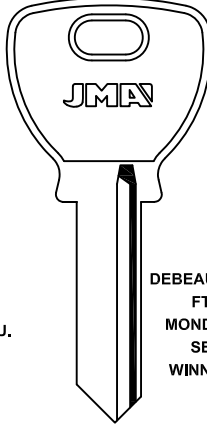
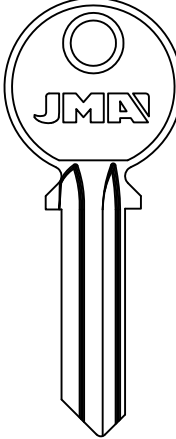
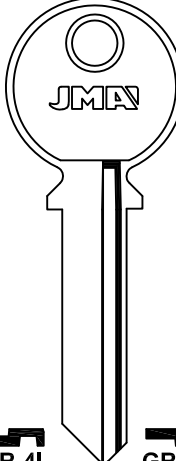











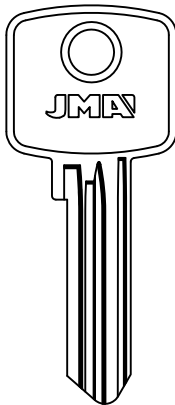
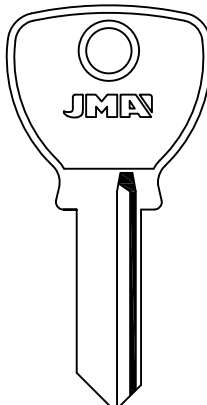
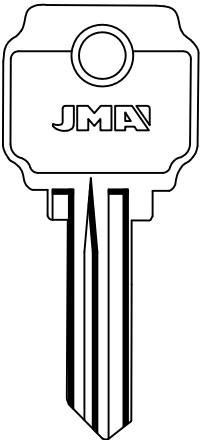
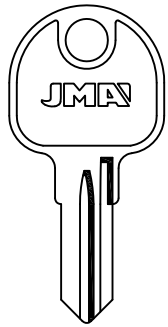



41  
GUA-2D

FAB

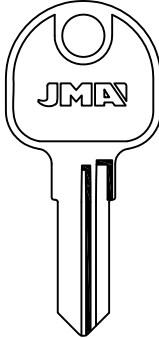
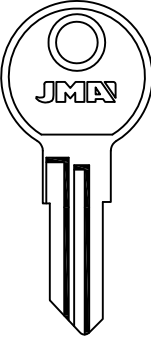
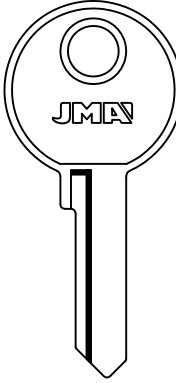
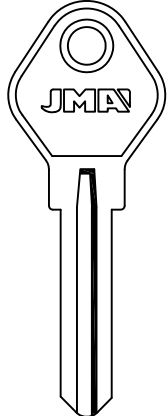







**PARA-FOR:**

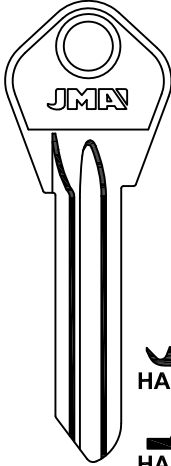
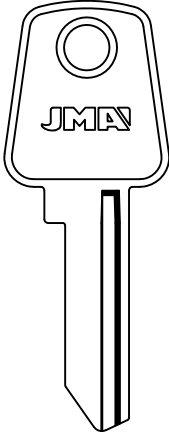
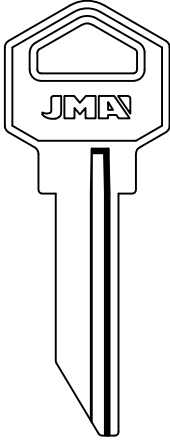
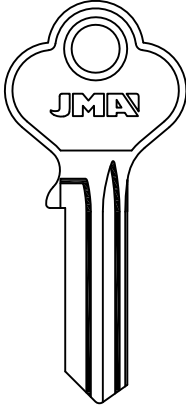







- GUARD (HK)
- GUERVILLE R. (F)
- HÄFELE (D)
- HAGA (RC)
- HALLE (USA)

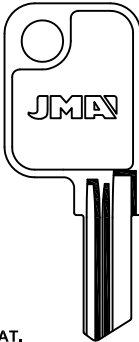
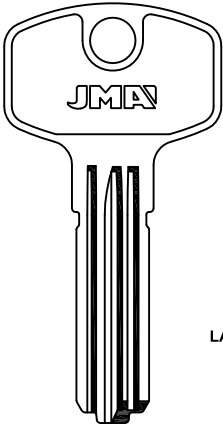
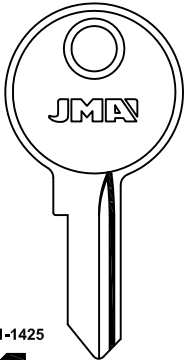
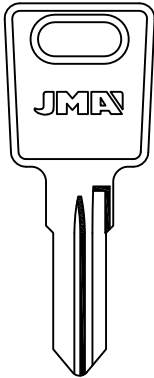



| GUARD  | GUERVILLE R.   |   |  |
|--|--|---|--|
|   |  <p>ALU.</p> <p>DEBEAURAIN<br/>FT<br/>MONDIAL<br/>SE<br/>WINNER</p>   |   |   |
|  GUA-3  GUA-3D     |  GR-1I  GR-1D<br> GR-2I  GR-2D |  GR-3I  GR-3D<br>PERRIER |  GR-4I  GR-4D<br> GR-5I  GR-5D |
| GUERVILLE R.   |  | HÄFELE  |  |
|    |    |    |    |
|  GR-6  GR-6D   |  GR-7  GR-7D   |  GR-8<br>MONDIAL   |  HAF-1  HAF-1D<br> HAF-4  |
| HÄFELE   |  | HAGA  | HALLE  |
|   |   |   |   |
|  HAF-2  HAF-2D |  HAF-3D   |  HAG-1D  |  HAL-1  |

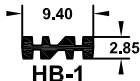

| HARKOV  |  |  | HARLOC   |
|---|--|--|--|
|            |           |           |           |
| <br>HAK-1D |  |  |  |
| <br>HAK-2D |  |  |  |
| <br>HAK-5  | <br>HAK-3 | <br>HAK-4 | <br>HAR-1 |
|   |  |  | DNS-EAGLE-LORI   |

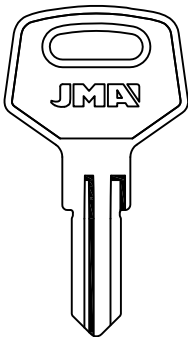
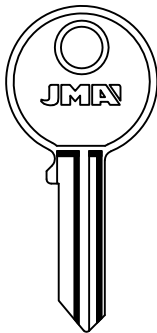
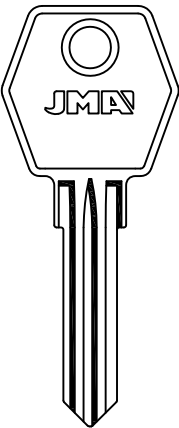
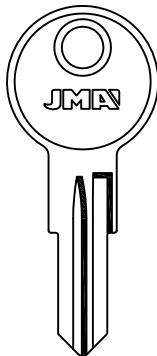
**PARA-FOR:**  
HARKOV (RUS)  
HARLOC (USA)  
HAYWORTH (USA)  
HB (I)  
HEKNA (D)  
HELIX (RC)  
HENDERSON (USA)  
HERME (RC)











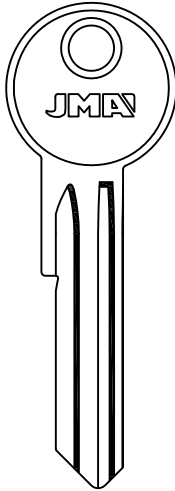
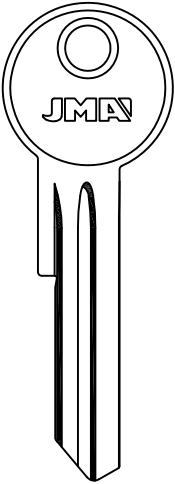
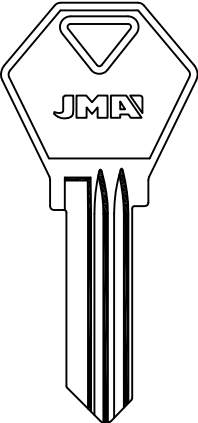
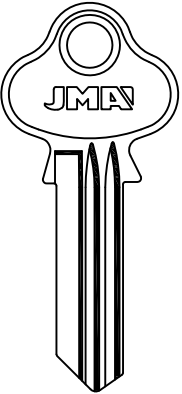



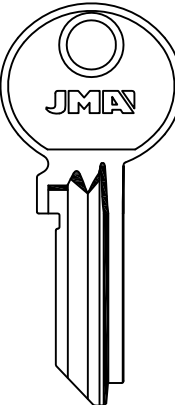
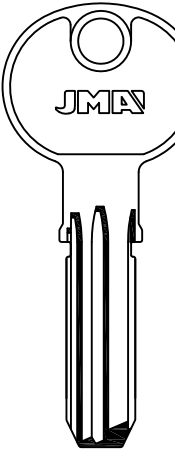
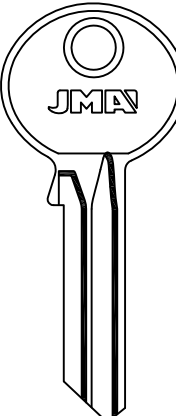
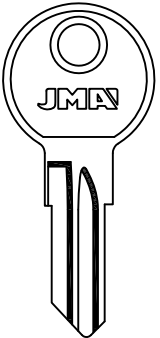

| HAYWORTH  | HB  | HEKNA  |  |
|---|---|--|--|
|              |           |            |            |
| LAT.  | LAT.  | ....1001-1425  |  |
| <br>HAW-1D |   | <br>HEK-1 |  |
| <br>HAW-2D |   | <br>HEK-2 |  |
| <br>HAW-3D | <br>HB-1 | <br>HEK-3 | <br>HEK-4 |
|   | LEGALLAIS   | METALCASTELLI-RAUCO-REGENT   | METALCASTELLI-RAUCO-REGENT   |

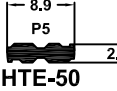
| HELIX  | HENDERSON  |  | HERME  |
|--|--|--|--|
|           |           |           |           |
|  | R<br>008-254   |  |  |
| <br>HEL-1 | <br>HEN-1 | <br>HEN-2 | <br>HRM-1 |
|  | REAGENT  |  |  |

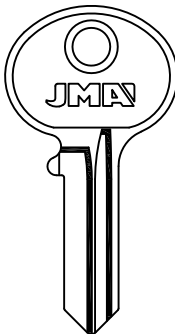
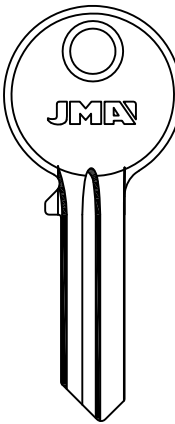
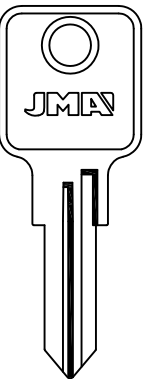
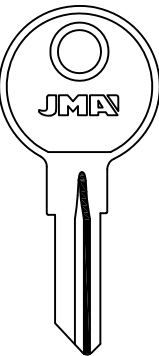

**PARA-FOR:**

- HOBES (RCZ)
- HORSE (RC)
- HTEC (E)
- HTV (GB)
- HUDSON (USA)
- HUNIT (I)
- HUWIL (D)

| HOBES  |   | HORSE  |  |
|--|---|--|--|
|           |                  |                    |   |
|  HOB-1    |  HOB-2D          |  HOR-1            |  HOR-2  HOR-2D |
| HTEC   |   | HTV  | HUDSON   |
|          |                 |                   |    |
|  HTE-1D |  HTE-50<br>THT |  HT-1<br>VAUGHN |  HUD-2D   |
|  | LAT.<br>8,9<br>P5<br>2,41   |  |  |
| HUDSON   | HUNIT   | HUWIL  |  |
|         |                |                  |   |
|  HUD-3  |  HUN-1D<br>FTH |  HUW-1           |  HUW-2  |
|  |   |  HUW-1D         |  HUW-3D   |
|  |   | W<br>3000-4000<br>A<br>3001-4000   | V  |
|  |   | STRAFOR-STEELCASE  | CEKA-HÄFELE-MAUSER-SCHÄRF  |





| HUWIL   | IBEAR                                 | ICA       |             |
|---|---------------------------------------|-----------|-------------|
|   |                                       |           |             |
| N<br>0005-1878<br>N<br>2001-2204<br><br>HUW-N | <br>IB-1<br><br>IB-2<br>ICA-SERRALLER | <br>ICA-1 | <br>ICA-4IP |
| TECNO   |                                       |           |             |

**PARA-FOR:**

- HUWIL (D)
- IBEAR (E)
- ICA (E)
- ICSA (I)
- IFAM (E)

| ICA         | ICSA              |            | IFAM                     |
|-------------|-------------------|------------|--------------------------|
|             |                   |            |                          |
| <br>ICA-5IP | <br>ICS-1D        | <br>ICS-2D | LAT.<br><br>IF-1<br>JOMA |
|             | ORLANDO-REMO-ZANI |            |                          |

| IFAM             |                    |                  |          |
|------------------|--------------------|------------------|----------|
|                  |                    |                  |          |
| ALP.<br><br>IF-2 | ALP.<br><br>IF-3.P | ALP.<br><br>IF-4 | <br>IF-5 |
|                  |                    |                  |          |



**PARA-FOR:**

IFAM (E)

IGS (F)

IKON (D)

**IFAM**

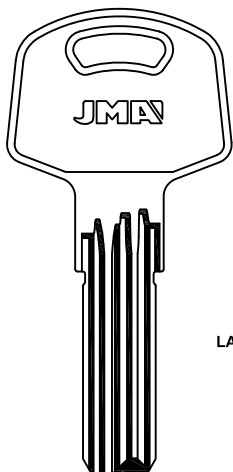

LAT.

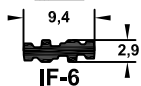

IF-6

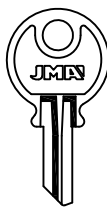

IF-15

TEM

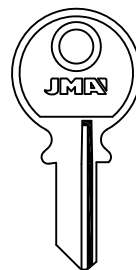

IF-120

ABUS-JOMA-TEM-TESA

IF-D20

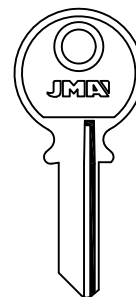

IF-125

\* IF-D25

BATU-FADE-JOMA  
GUARD-RIPA-TEM

**IFAM**

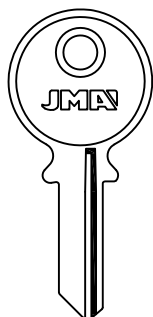

IF-130

JOMA



IF-D30

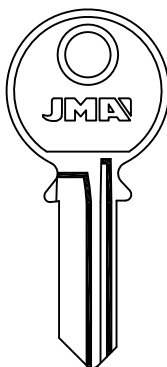

LAT.  
ALU.



IF-140

RIPA

IF-35

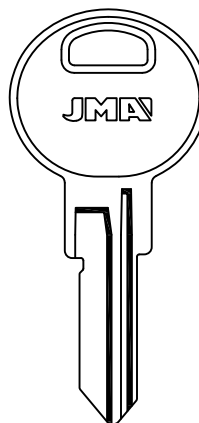

IF-140L

RIPA

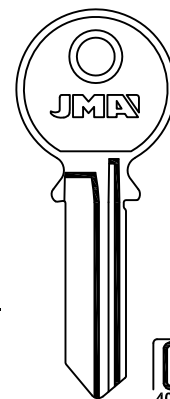

\* ALU.  
\* LAT.  
\* FSH.



IF-150



\* IF-45/55

\*50\*

IF-151

**IFAM**

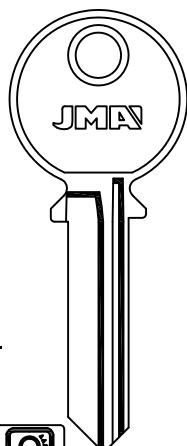

LAT.



IF-160/70

IF-60/70

**IGS**

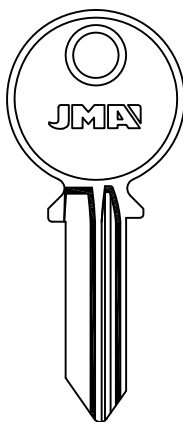

IGS-1

**IKON**

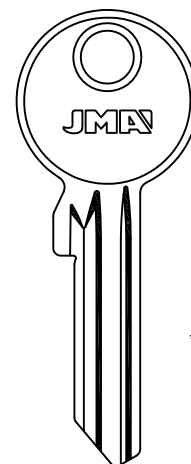

\* LAT.

SN4



ZE-1

SN2



ZE-2

N2



ZE-6

SN3



ZE-1D

SN1



ZE-2D

N1



ZE-6D

M



ZE-9D

SN5



\* ZE-14D

BRUMME-OTIS



# IKON

PARA-FOR:

IKON (D)

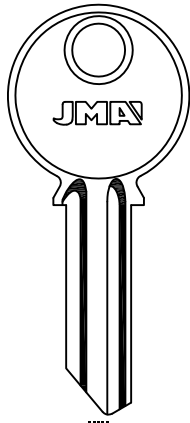

.....  
1 AL 9 AL 0  
A-B-C-D-E-F-G-H-I-L



BRUMME-OTIS

# IKON

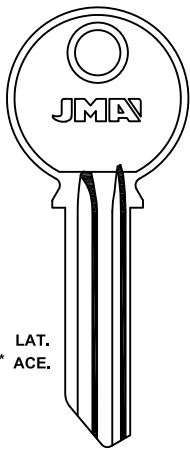

LAT.  
\* ACE.



LAT.



PARA-FOR:

IKON (D)

IKON

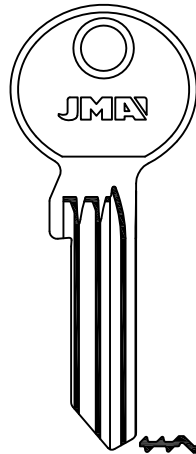

ZE-10D

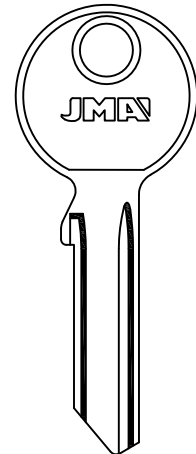

ZE-13

ZE-11D

IKON

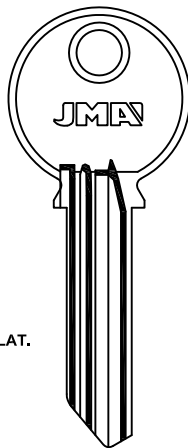

LAT.



ZE-65D



ZE-66D



ZE-67D



ZE-68D



ZE-69D



ZE-110D



ZE-117D



ZE-60D



ZE-61D



ZE-62D



ZE-63D



ZE-64D



ZE-109D



ZE-116D



ZE-55D



ZE-56D



ZE-57D



ZE-58D



ZE-59D



ZE-108D



ZE-115D



ZE-50D



ZE-51D



ZE-52D



ZE-53D



ZE-54D



ZE-107D



ZE-114D



ZE-33D



ZE-34D



ZE-47D



ZE-48D



ZE-49D



ZE-106D



ZE-113D



ZE-28D



ZE-29D



ZE-30D



ZE-31D



ZE-32D



ZE-105D



ZE-112D



ZE-23D



ZE-24D



ZE-25D



ZE-26D



ZE-27D



ZE-70D



ZE-111D



ZE-147D



ZE-146D



ZE-145D



ZE-141D



ZE-136D



ZE-127D



ZE-126D



ZE-125D



ZE-148D

LAT.

PERFIL Z SERIE 400



## IKON

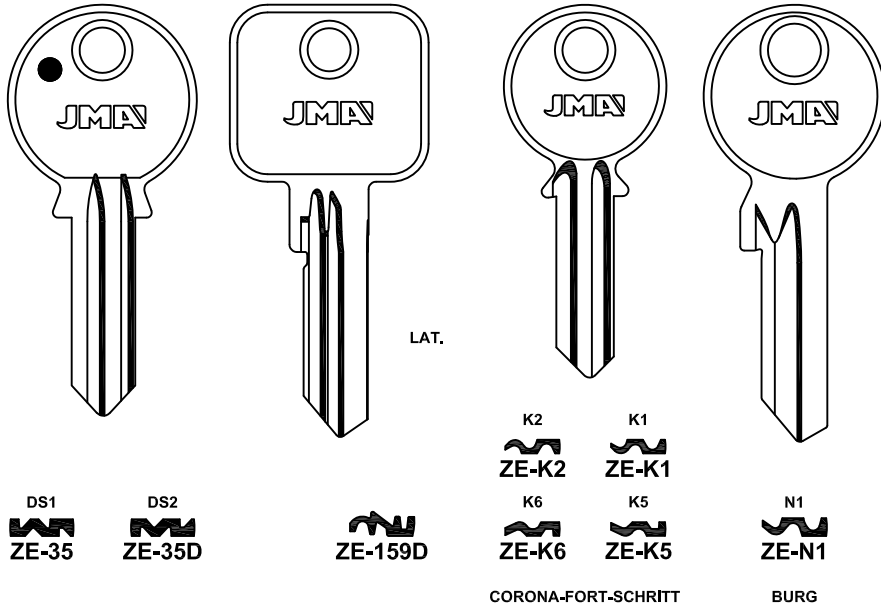

## ILARGI

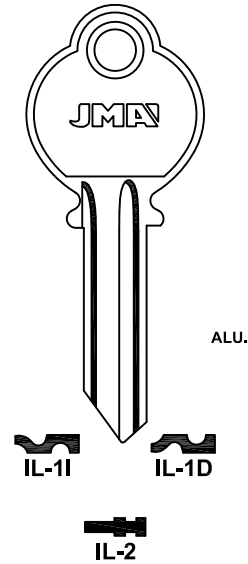

## PARA-FOR:

IKON (D)  
ILARGI (E)  
ILCO (USA)  
ILLINOIS (USA)  
ILS (I)  
IMB (KW)

## ILCO

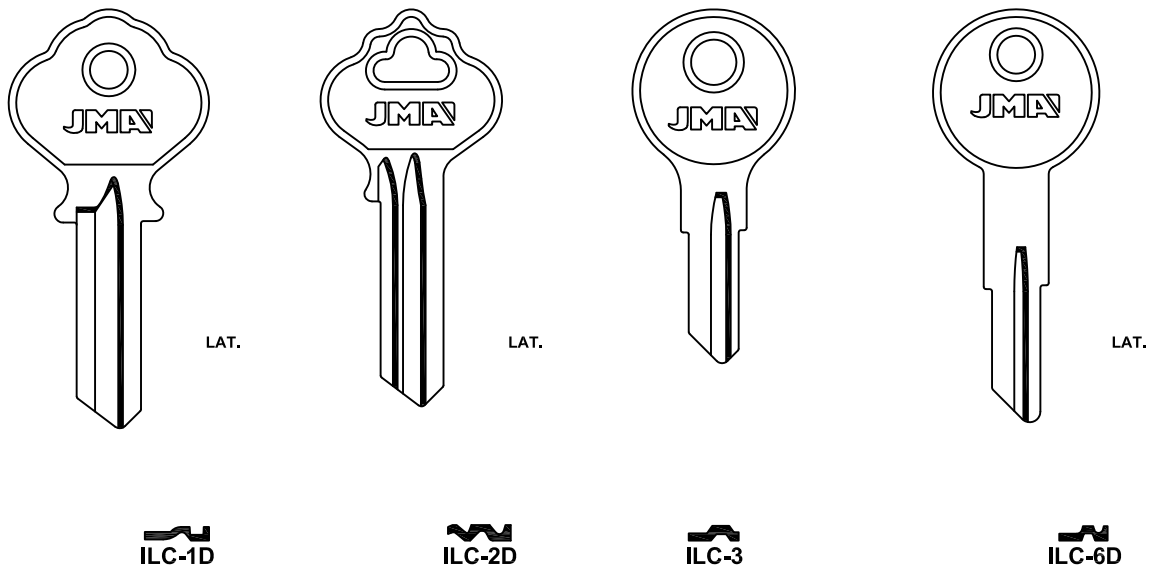

## ILLINOIS

## ILS

## IMB

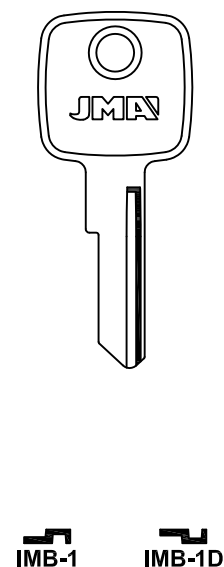
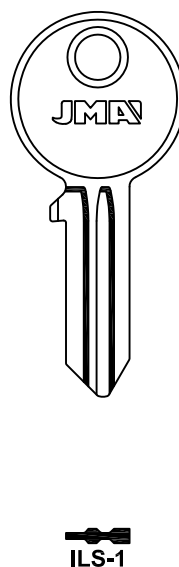
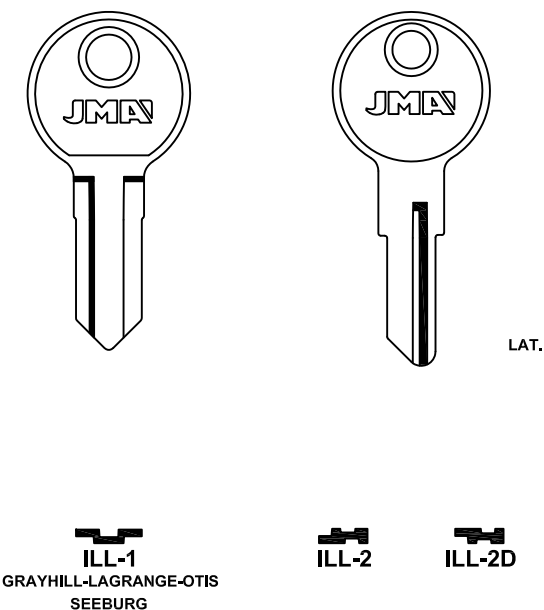

**PARA-FOR:**











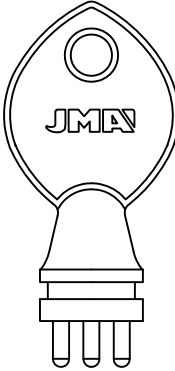
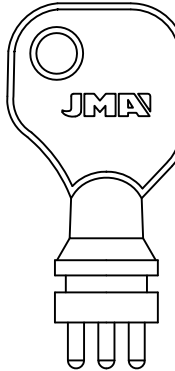

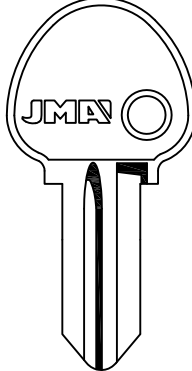
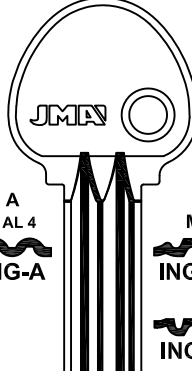

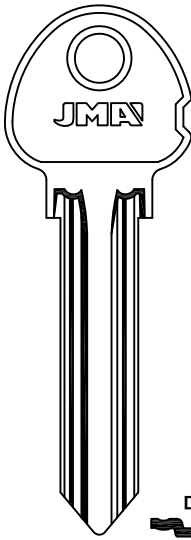
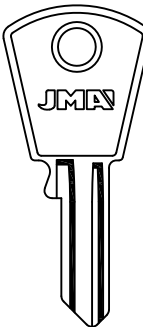

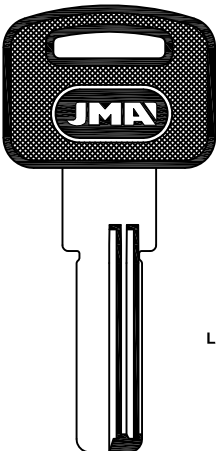
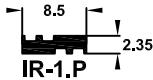
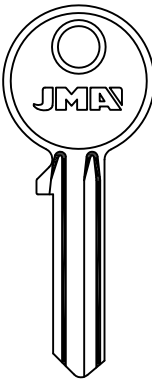

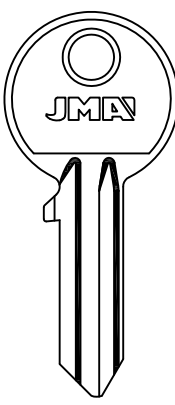

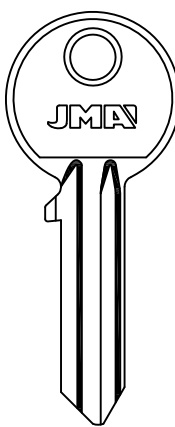

INCECA (E)

INGERSOLL  
(USA)

INT (D)

IR (F)

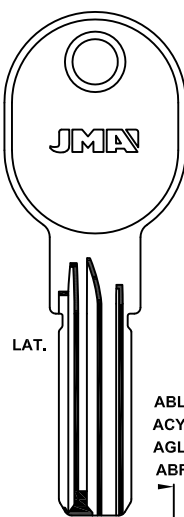
ISEO (I)

| INCECA  |   | INGERSOLL   |  |
|---|---|---|--|
|  <p>LAT.</p>  <p>LAT.</p>  <p>INCE-1E</p>  <p>INCE-2E</p> |   |   <p>A<br/>1 AL 4<br/>ING-A</p> <p>M<br/>ING-M</p> <p>ING-N</p> <p>S<br/>1 AL 4<br/>ING-S</p> <p>W<br/>ING-W</p>  <p>ING-6</p>  |  |
| INGERSOLL   | INT   | IR  | ISEO   |
|  <p>D<br/>ING-D</p>   |  <p>LAT.</p>  <p>INT-1</p>  <p>INT-1D</p>           |  <p>LAT.</p>  <p>8,5 2,35<br/>IR-1.P<br/>BYP-IFAM</p>   |  <p>ALU.</p>  <p>1 AL 5<br/>IS-1I</p>  <p>IS-1D<br/>TESA</p>         |
| ISEO  |   |   |  |
|  <p>....1-2000<br/>Y....1-2000<br/>0 AL 8</p>  <p>IS-2I</p>  <p>IS-2D</p>  |  <p>*ALU.</p>  <p>IS-3I</p>  <p>F5<br/>* IS-3D</p> |  <p>IS-4</p> <p>....1-2000<br/>Y....1-2000<br/>0 AL 8</p>  <p>IS-5D</p>  <p>IS-7D</p>  <p>IS-8</p>  <p>IS-8D</p>  <p>IS-18D</p>  <p>IS-19D</p> |  <p>LAT.</p>  <p>ABL.....1-015328<br/>ACY.....1-015328<br/>AGL.....1-015328<br/>ABF.....1-015694<br/>9,4<br/>R6<br/>2,5<br/>IS-6D</p> <p>MD-VACHETTE</p> |



# ISEO

# PARA-FOR:

ISEO (I)

ITO (TR)

IVANA (D)

JARDI (E)

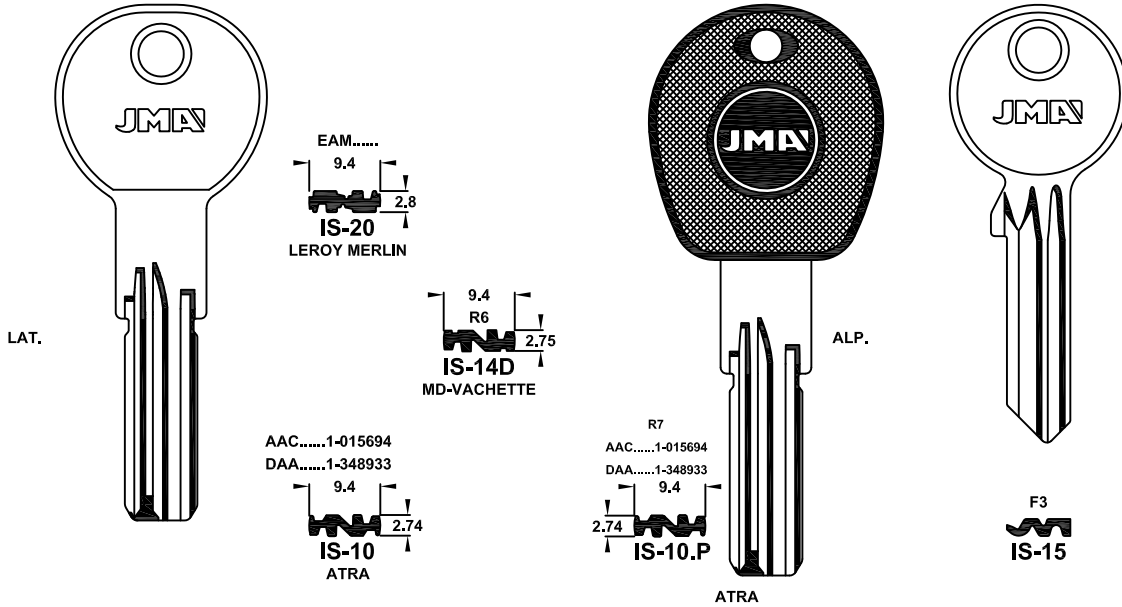

# ISEO

# ITO

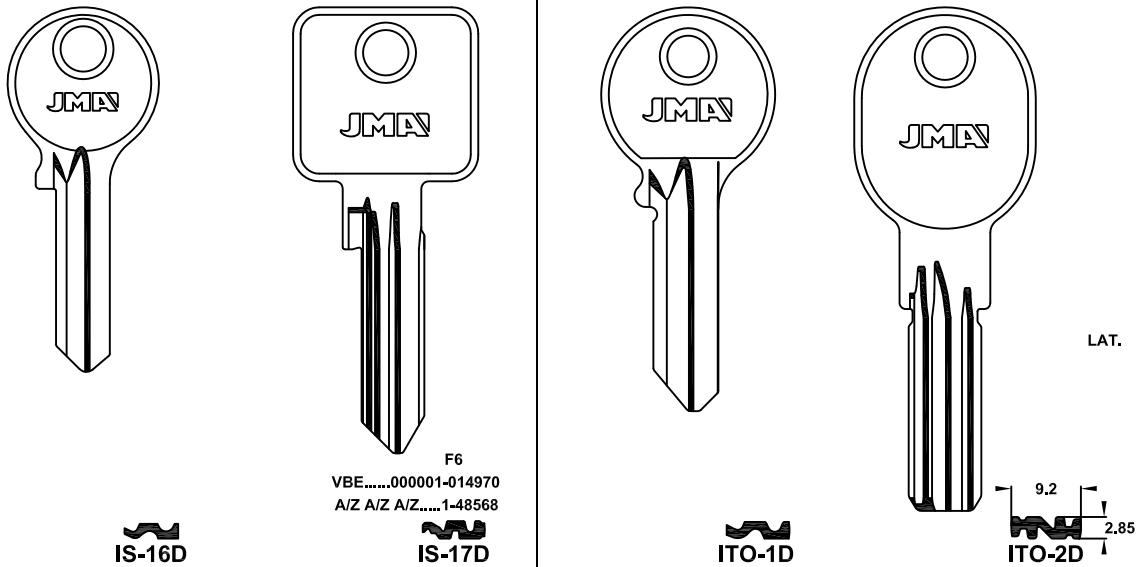





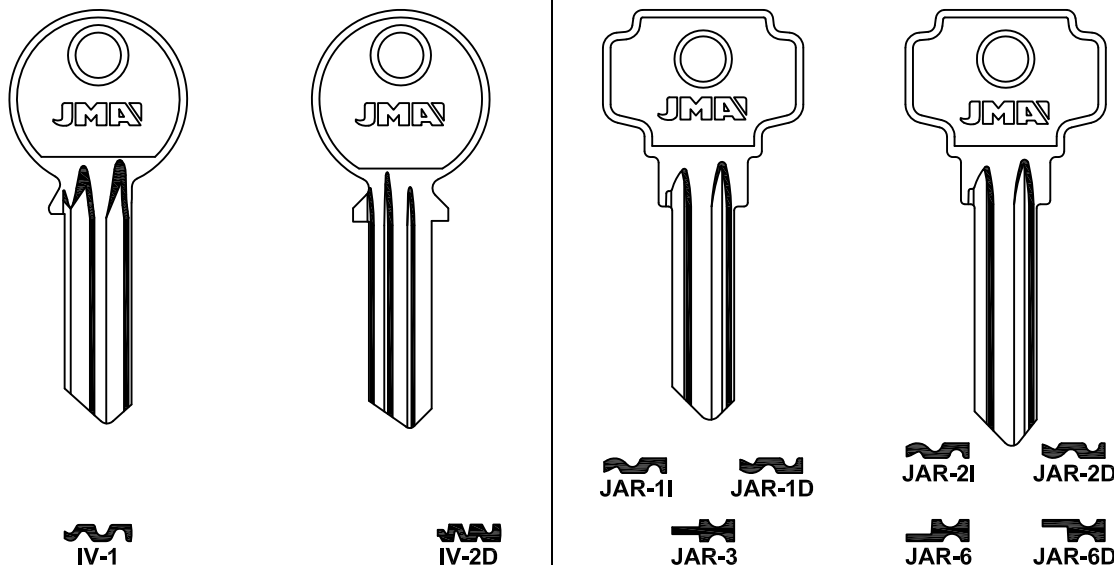

# IVANA



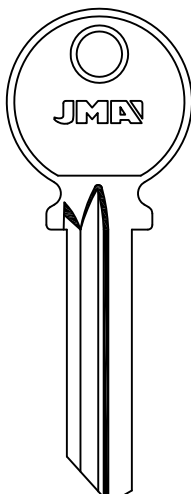
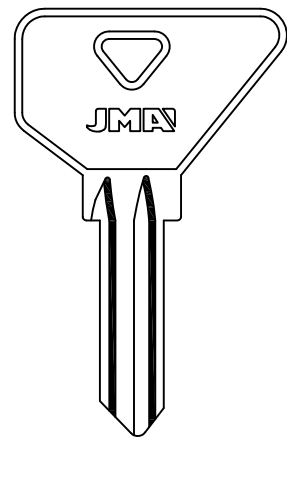
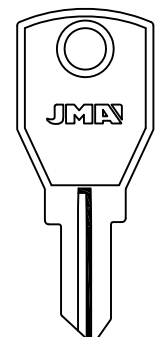
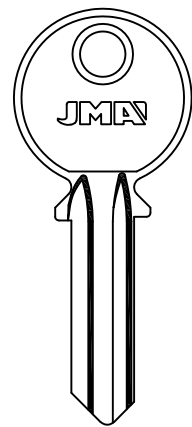



# JARDI



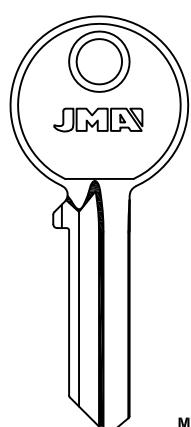
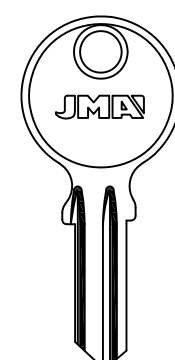
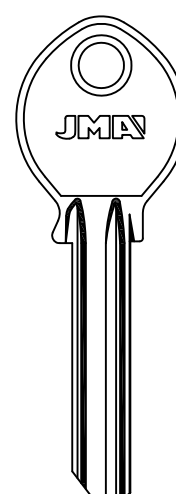
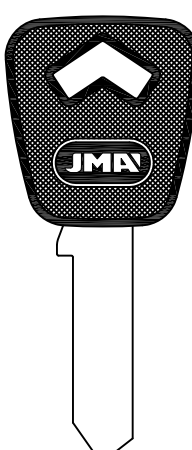



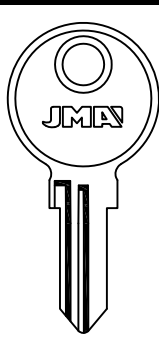
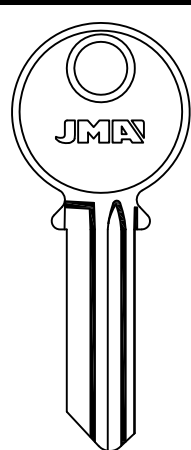
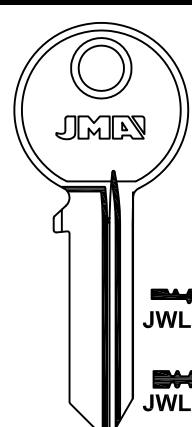
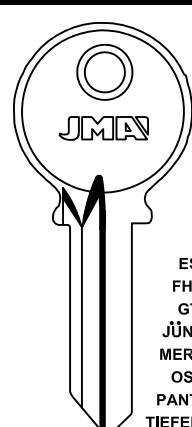

**PARA-FOR:**

- JARDI (E)
- JINLONG (RC)
- JIP (E)
- JIS (E)
- JOMA (E)
- JOVI (E)
- JOWIL (D)

| JARDI  | JINLONG  | JIP   |
|--|--|---|
|    |         |    |
|  JAR-4D  JAR-5I  JAR-5D |  JIN-1D |  JIP-1I  JIP-1D |

| JIS  |  |  |   |
|--|--|--|---|
|          |          |   |           |
| ALU.<br>LAT.<br>FSH.<br>MTIC.(J)   | LAT.<br>ALU.   | ALU.   | ALP.  |
|  JIS-1D |  JIS-2I |  JIS-3I  JIS-3D |  JIS-4.P |
| SEMEL  |  |  |   |

| JOMA   | JOVI   | JOWIL   |   |
|--|--|---|---|
|         |       |   |              |
|  JOM-1D |  JO-1 |  JWL-9  JWL-9D | ESZ<br>FHÜR<br>GTV<br>JÜNGST<br>MERCUR<br>OSKO<br>PANTHER<br>TIEFENTHAL<br>TRITON<br>VOKO<br>WEPA |
|  |  |  JWL-4D  |  JWL-2D      |
| GTV  |  |   |   |





## JOWIL

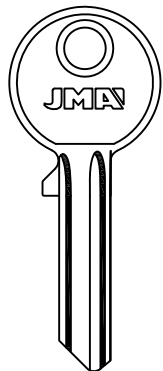

JWL-5

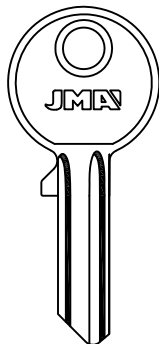

JWL-6

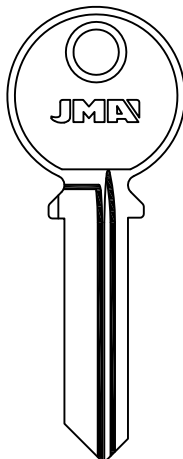

JWL-7D

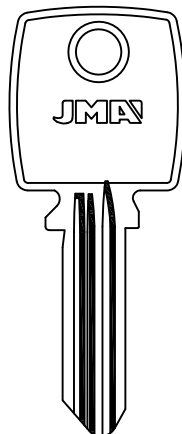

JWL-10D

LAT.

JWL-11D

## PARA-FOR:

JOWIL (D)

JPM (F)

JTF (F)

## JPM

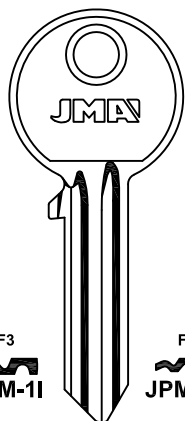

F3  
JPM-1I



F3  
JPM-1D

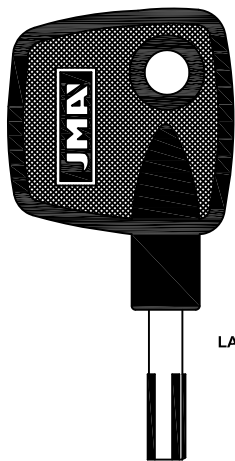

LAT.

JPM-1E

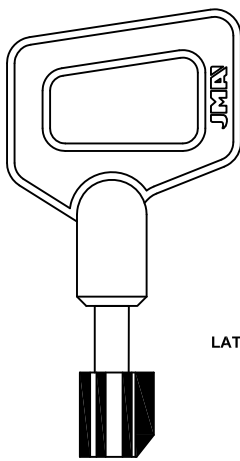

LAT.

JPM-2E

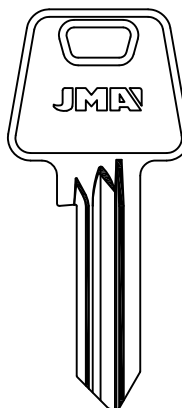

JPM-3D

JPM-2I

JPM-2D

JPM-4

JPM-4D

ABUS

## JPM

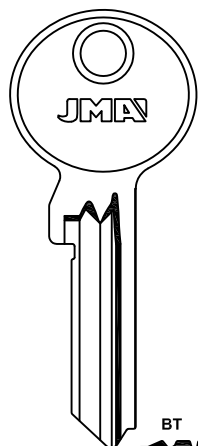

BT  
JPM-10D

BK  
JPM-11D

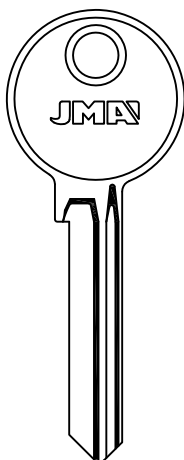

JTF-1I

## JTF

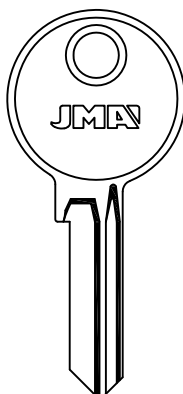

JTF-2I

JTF-3

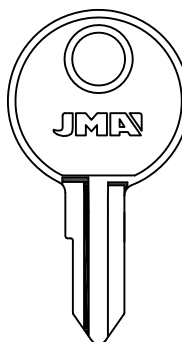

JTF-4



**PARA-FOR:**

- JU-JUNGINGER (D)
- JUNGHEINRICH (D)
- JUNIE (D)
- JUNKUNG (USA)
- JUZU (E)
- JVAL (P)
- KABA (CH)

| JU-JUNGINGER  | JUNGHEINRICH  | JUNIE   |   |
|---|---|---|---|
| <br><br><br><br>  | <br>  | <br><br><br><p style="text-align: center;">PEROHAUS-US</p>  | <br><br><br><br><p style="text-align: center;">PEROHAUS-US</p>              |
| JUNIE   | JUNKUNG   | JUZU  |   |
| <br><br><br><br><br><br>                                    | <br><p style="text-align: center;">LAT.</p><br><p style="text-align: center;">A.MOTORS-BULIT-LION</p> | <br><br><br><p style="text-align: center;">ALSO-A.MOTORS-BULIT-LION</p>   | <br>  |
| JVAL  |   | KABA  |   |
| <br><br><br><br><p style="text-align: center;">P.C.-FEB</p> | <br><br><br><br><br><br><p style="text-align: center;">P.C.-FEB</p>                                   | <br><p>S15-S16<br/>S17-S18<br/>S53-S58<br/>S59-S61</p><br><br><br><p style="text-align: center;">LÄSBOLAGET</p> | <br><p>* ALU.<br/>ALP.</p><br><br><p style="text-align: center;">GEMINI</p> |



# KABA

# PARA-FOR:

KABA (CH)

KABS (D)

KALE (TR)

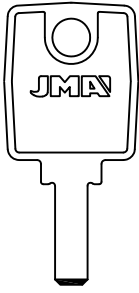

ALP.

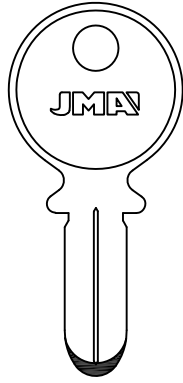

ALP.

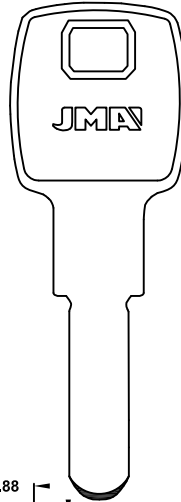

ALP.

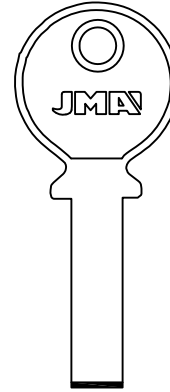

ALP.

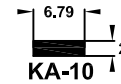
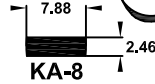
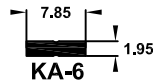
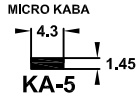

## KABA

## KABS

## KALE

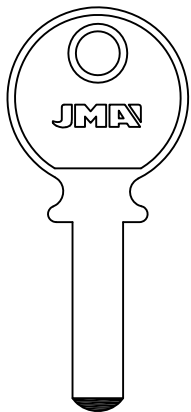

ALP.

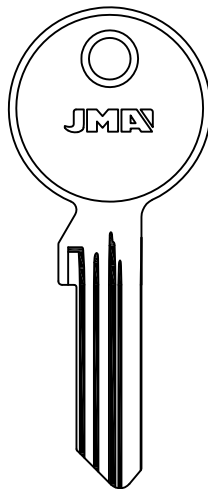

KAB-1D

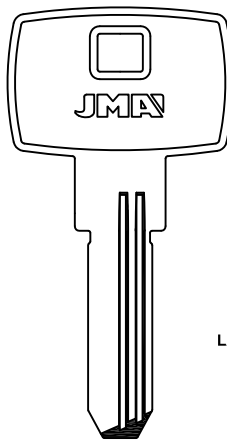

LAT.

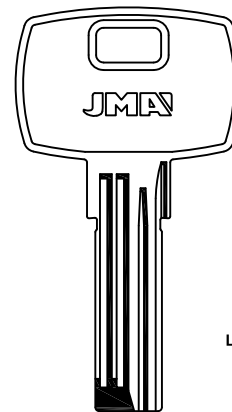

LAT.

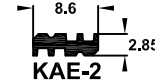
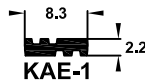

# KALE

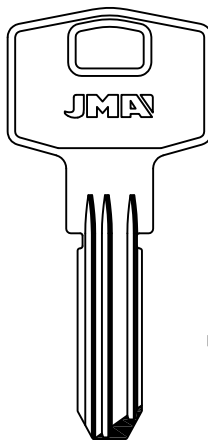
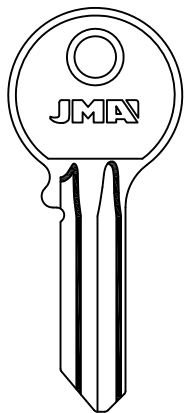

LAT.

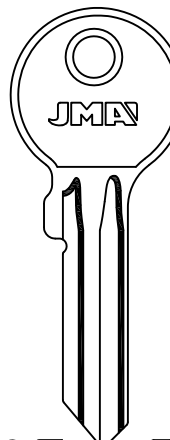
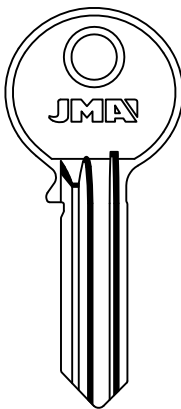

KAE-6

KAE-6D

KAE-3

KAE-3D

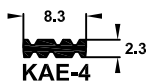

KAE-5

KAE-7

KAE-7D



**PARA-FOR:**

- KALE (TR)
- KALUGA (RUS)
- KAP (RUS)
- KAZAN (RUS)

**KALE**

LAT.

LAT.

KAE-8 KAE-8D

KAE-9 KAE-9D

KAE-10D

KAE-11D

KAE-12

KAE-13D

FAC-GAON JIS FAC

**KALE KALUGA KAP KAZAN**

LAT.

LAT.

KAE-14

KAL-1

KAL-2D

KAP-1D

KAP-2D

KAZ-1

**KAZAN**

KN

KAZ-2

KAZ-3

KAZ-4

KAZ-5

KAZ-5D



**KAZAN**

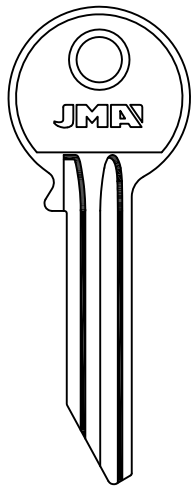

**KAZ-6**

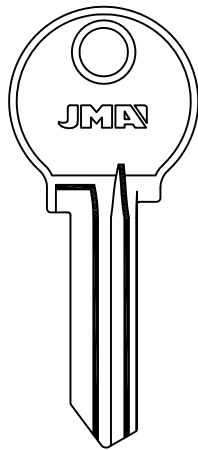

**KAZ-7**

**KESO**

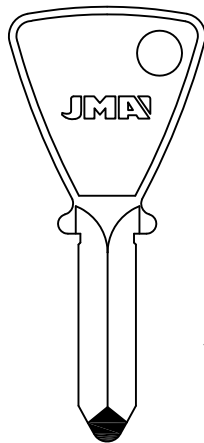

**KE-1**  
7.49  
2.7

JPM

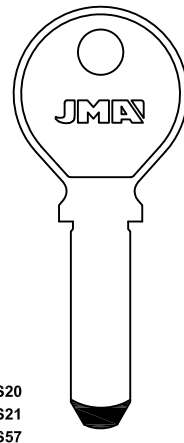

**KE-3**  
7.6  
2000  
2.45

ALP.

ALP.

S20  
S21  
S57

**PARA-FOR:**

- KAZAN (RUS)
- KESO (CH)
- KFV (D)
- KICHINEV (RUS)
- KIFERM (F)

**KESO**

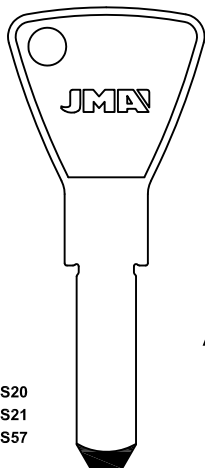

S20  
S21  
S57

**KE-4**  
7.6  
2000  
2.45

ALP.

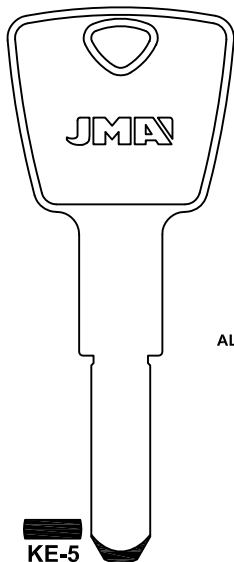

**KE-5**

ALP.

**KFV**

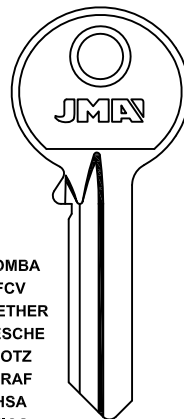

COMBA  
FCV  
FLIETHER  
GIESCHE  
GOTZ  
GRAF  
HSA  
NICO  
SEN  
SCHUCO

ALU.

**KFV-1**

**KFV**

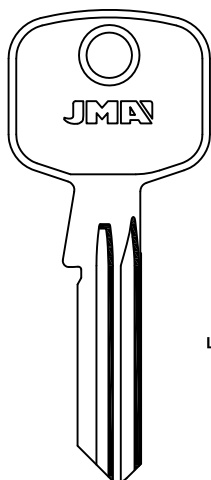

LAT.

**KFV-O**

**KFV-N**

**KFV-M**

**KFV-L**

**KFV-F**

**KFV-E**

**KFV-D**

**KFV-C**

COMBA-FCV-FLIETHER-GIESCHE  
GOTZ-GRAF-HSA-NICO-SCHUCO-SEN

**KICHINEV**

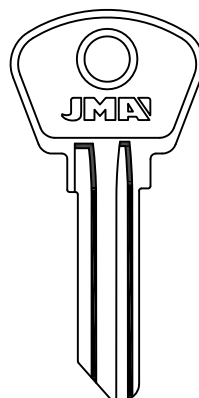

**KIC-1**

**KIFERM**

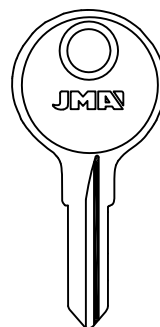

**KIF-1**











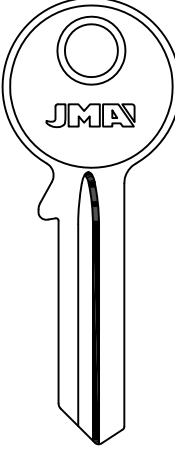
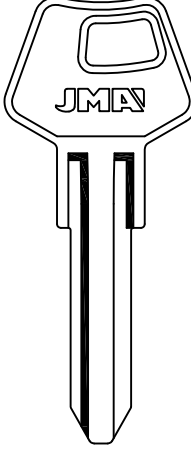

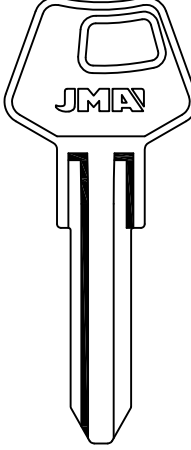

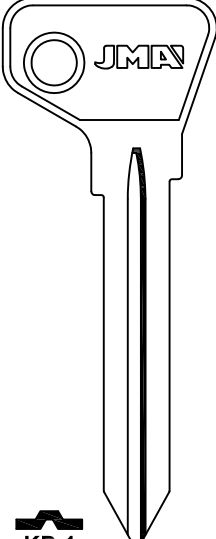

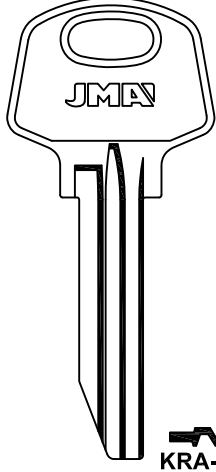

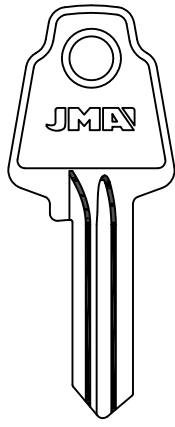

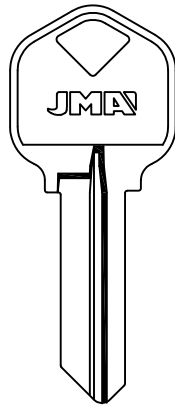

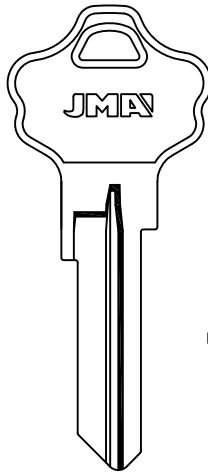

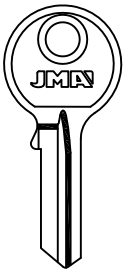
**KIF-1D**

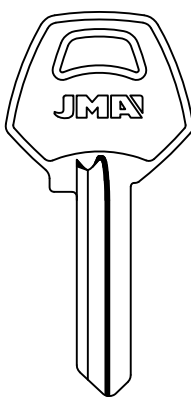
**KIF-2D**

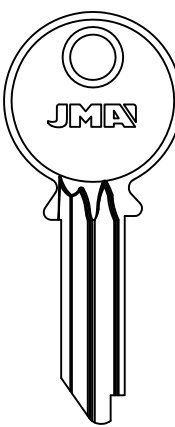

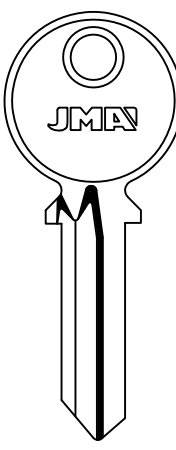
**PARA-FOR:**

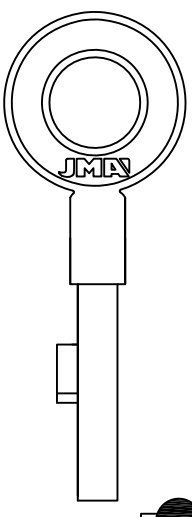
- KIROVMACH (RUS)
- KP (RUS)
- KRAMATORSK (RUS)
- KREMENCHUG (RUS)
- KWIKSET (USA)
- KYNNARPS (GB)
- LAFONTE (BR)
- LAPERCHE (F)

| KIROVMACH  | KP  |   | KRAMATORSK   |
|--|---|---|--|
| <br><br><br><b>KIR-1D</b> | <br><br><b>KIR-2</b>  | <br><br><b>KP-1</b>   | <br><br><b>KRA-1D</b><br><br><br><b>KRA-2</b> |
| KREMENCHUG   | KWIKSET   |   | KYNNARPS   |
| <br><br><b>KRE-1D</b>   | <br><p>ACE.<br/>LAT.</p> <br><b>KWI-1</b><br><small>BRICARD-EZSET-VACHETTE</small> | <br><p>LAT.</p> <br><b>KWI-2D</b><br><small>TITAN</small> | <br><br><b>KNA-1D</b>   |
| LAFONTE  | LAPERCHE  |   |  |
| <br><br><b>LAF-1D</b>  | <br><br><b>LAP-1</b>  | <br><br><b>LAP-2D</b>                                    | <p>LAT.</p> <br><br><b>LAP-2E</b>  |



## LAPERCHE

PARA-FOR:  
LAPERCHE (F)

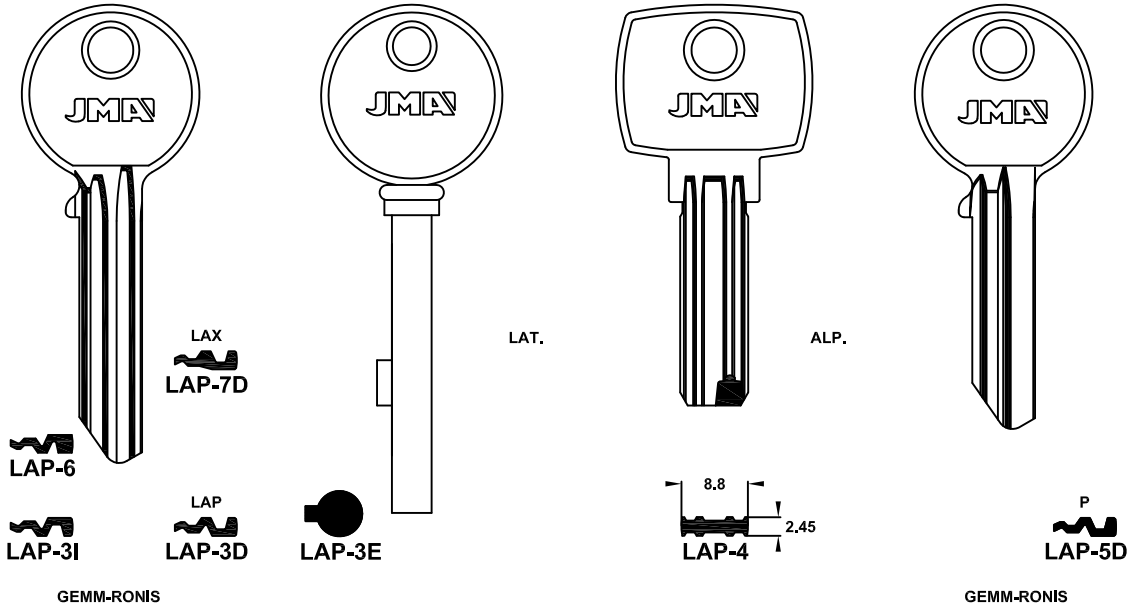

## LAPERCHE

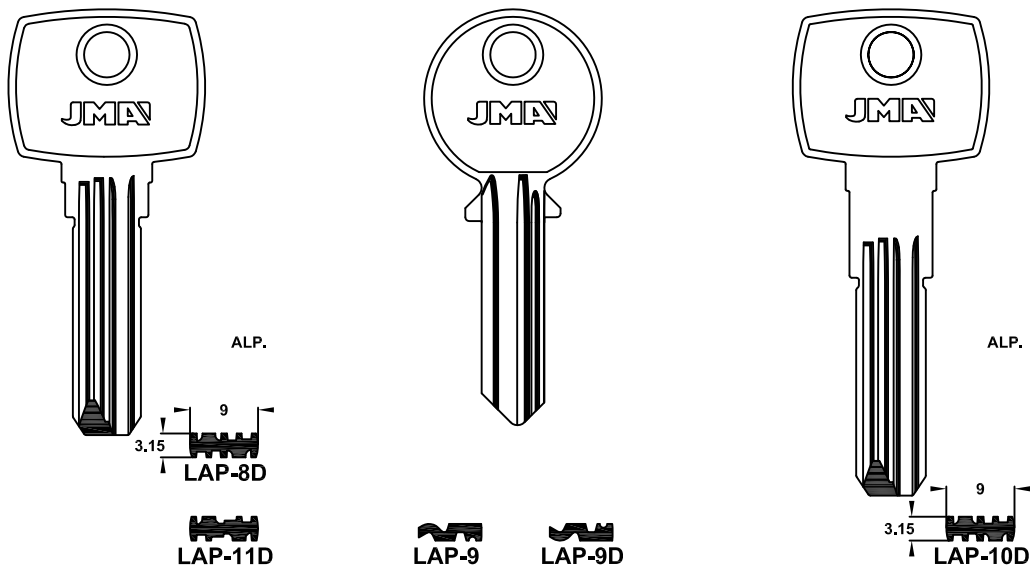

## LAPERCHE

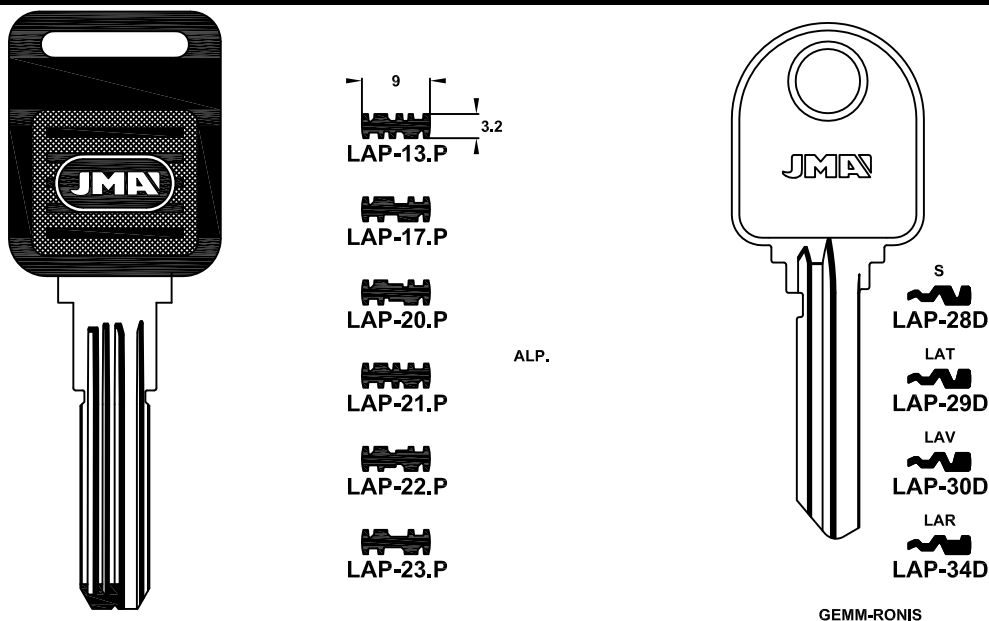

**PARA-FOR:**

LAPERCHE (F)

LAPORTE (F)

LARK (RC)

LAS (F)

**LAPERCHE**

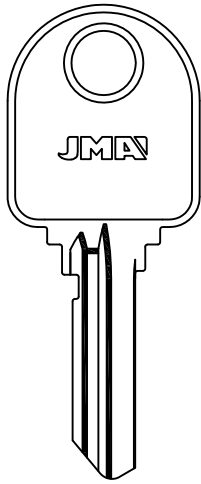

S  
LAP-42D

X  
LAP-43D

T  
LAP-44D

V  
LAP-45D

R  
LAP-46D

GEMM-RONIS

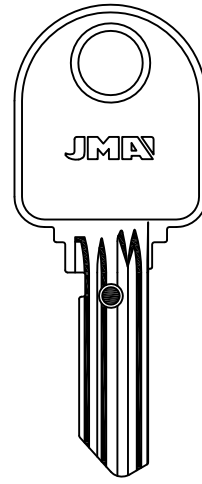

BDC  
LAP-88

FICHET

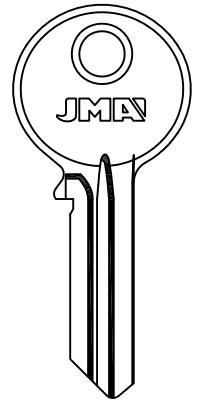

LAP-96D

VACHETTE

**LAPORTE**

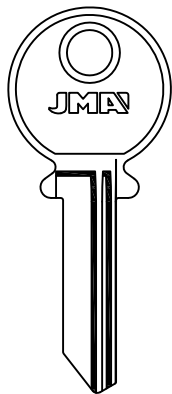

LPO-1

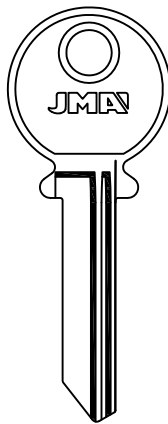

LPO-2

**LARK**

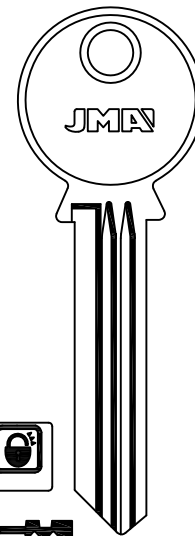

LAR-11

**LAS**

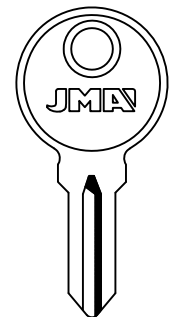

AX  
001-224  
LAS-AX

EX  
LAS-1D

ATAL-HÄFELE-KIFERM-RENZ

**LAS**

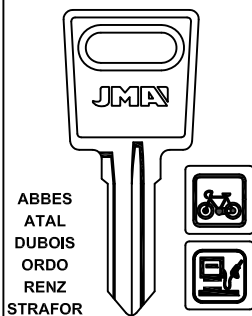

FM  
LAS-2

FM  
001-400  
501-550  
LAS-4



FH  
001-400  
501-550  
LAS-FH

LAS-4D

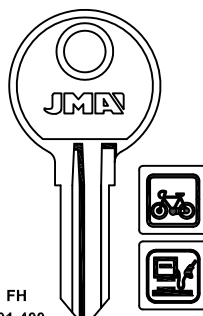

FH  
001-400  
501-550  
LAS-3

H  
LAS-5

U  
LAS-U

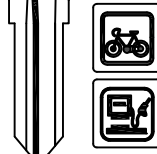

KIFERM

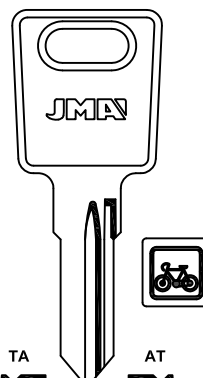

TA  
LAS-6

RM  
0001-2000  
KT  
3001-4000  
LAS-KT

ATAL-KIFERM-MARCADET-RONIS



AT  
LAS-6D

TK  
4001-5000  
LAS-TK

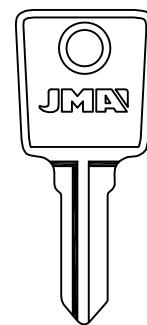

LAS-7

ABBES-ORDO

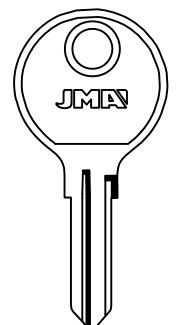

LS  
LAS-8

L  
LAS-9





# LAS

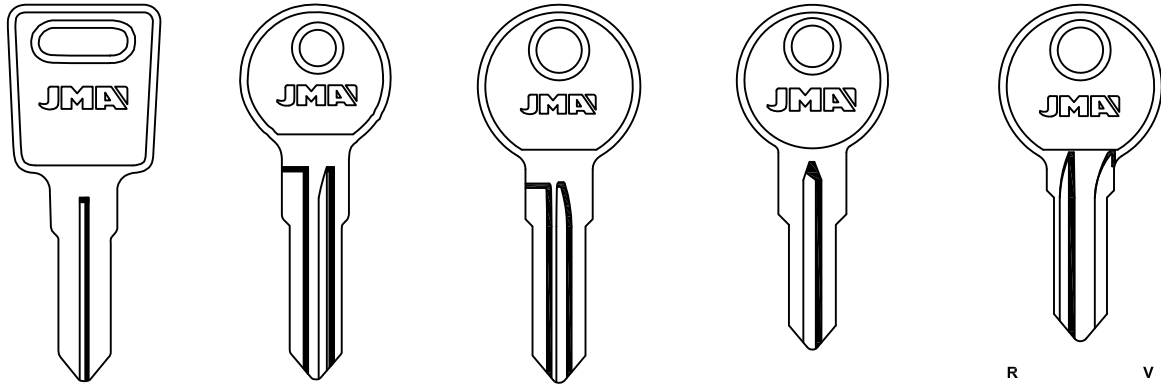

PR  
LAS-10

LAS-11

A...1-650  
LAS-11D

LAS-12D

AX  
001-224  
LAS-AX/L

R  
001-224  
LAS-R

V  
001-224  
LAS-V



Y  
001-224  
LAS-Y

MARCADET

ATAL-KIFERM-RENZ

ATAL-HÄFELE-KIFERM-RENZ

DUBOIS-KIFERM-PJ-PK

# PARA-FOR:

LAS (F)

LÅSBOLAGET (S)

LEGALLAIS (F)

LEGE (GB)

LINCE (E)

## LAS

## LÅSBOLAGET

## LEGALLAIS

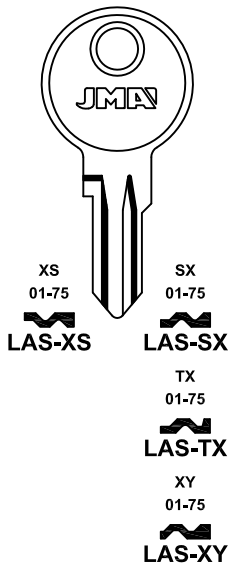

ATAL-JU-KIFERM-METEOR-RENZ

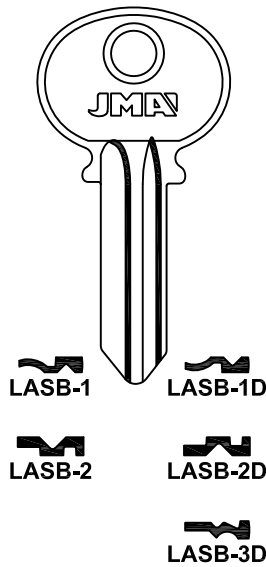

TANLOCKS

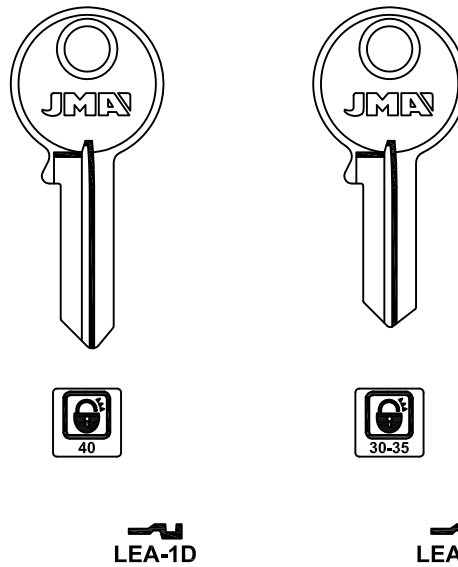

## LEGE

## LINCE

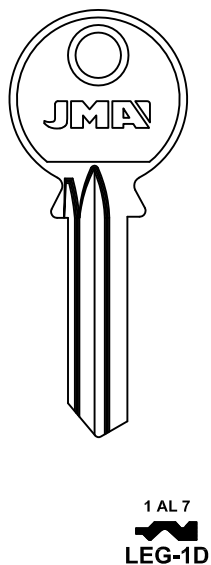

1 AL 7  
LEG-1D

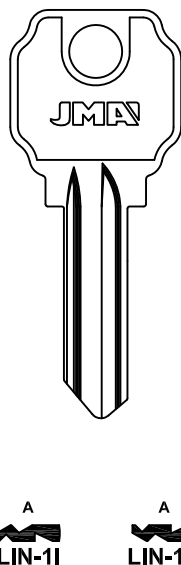

A  
LIN-11  
A  
LIN-1D

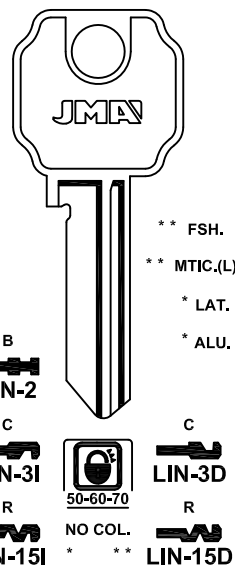

B  
LIN-2  
C  
LIN-31  
R  
LIN-151  
NO COL.  
\* \*\*

\*\* FSH.  
\*\* MTIC.(L)  
\* LAT.  
\* ALU.

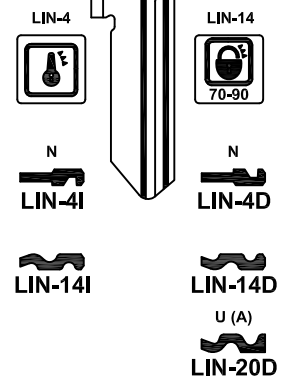

LIN-4  
LIN-14  
N  
LIN-4I  
N  
LIN-4D  
LIN-14I  
LIN-14D  
U (A)  
LIN-20D



**PARA-FOR:**

LINCE (E)

LIPS (NL)

**LINCE**

\* LAT.

D LIN-5I      D LIN-5D

T LIN-12I      T LIN-12D

D1 LIN-18      D1 LIN-18D

E LIN-6I      E LIN-6D

F LIN-7I      F LIN-7D

J LIN-8I      J LIN-8D

30-40      20-25      25

**LINCE**

ALP.

M LIN-10I      M LIN-10D

K LIN-9      S LIN-16      S LIN-16D

O LIN-11I      O LIN-11D

60-70      60-70      15

9      2.45      9      2.45

LIN-13

**LINCE**

LAT.

LAT. WNC.

9      2.45      9      2.45

R LIN-25      R LIN-25D

LIN-19D      LIN-21D

**LIPS**

30      35

LIP-11      LIP-1D

CRAIN-ICSA-SIB



LIPS

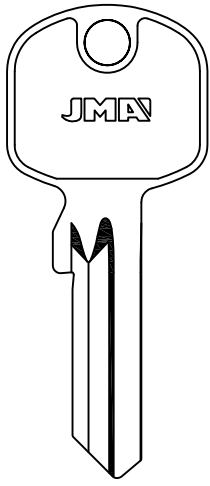

35  
LIP-1GD

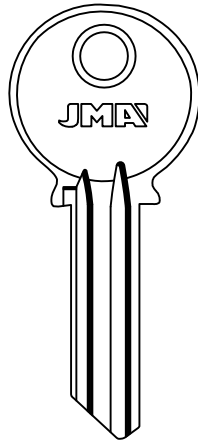

34  
LIP-2

29  
LIP-2D

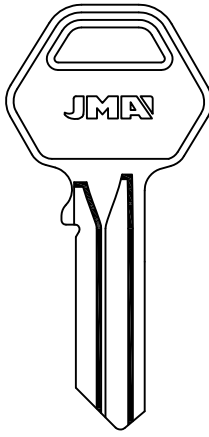

26  
LIP-3

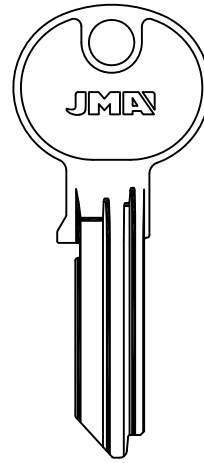

E03  
LIP-4

PARA-FOR:

LIPS (NL)

LITTO (B)

LOB (PL)

LIPS

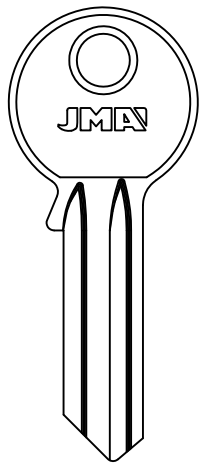

33  
LIP-33

28  
LIP-28D

LITTO

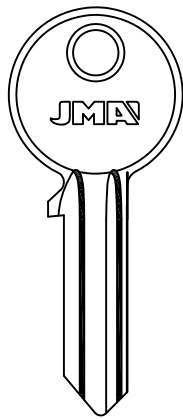

E  
LIT-11

ANKERSLOT

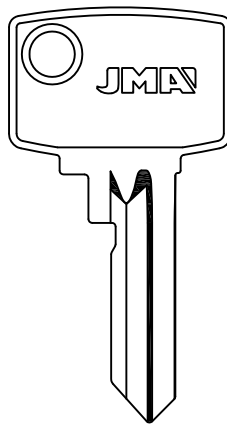

LIT-2D

ALU.  
MTIC.

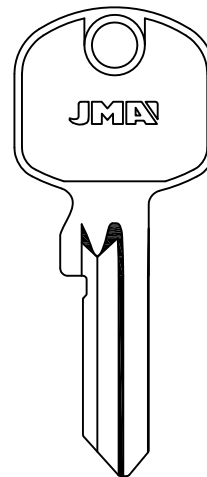

LIT-2GD

LITTO

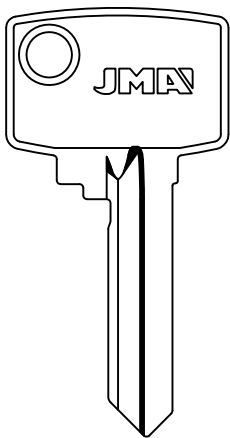

LIT-3D

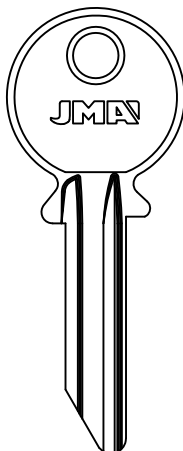

LIT-5I

LIT-5D

BKS

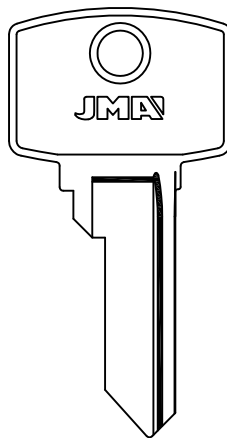

LIT-7D

LOB

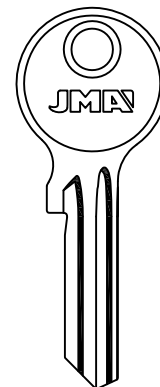

LB-1







LB-1D



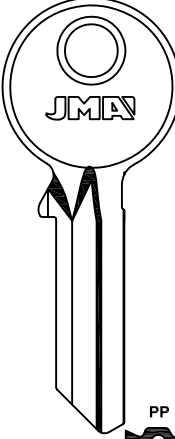
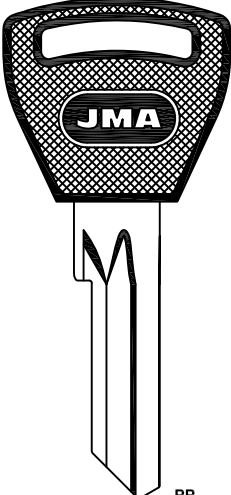
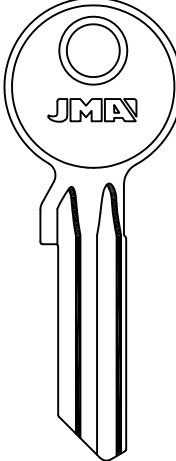
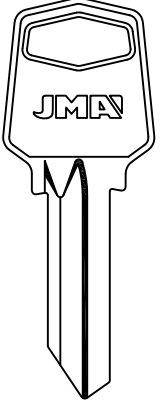





EXPRES

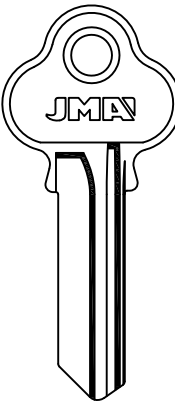
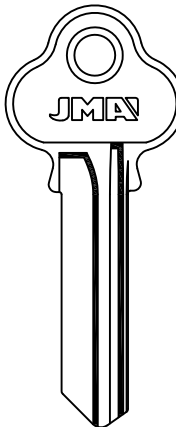
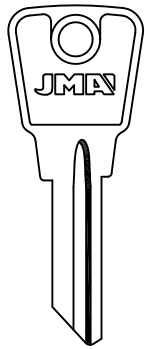
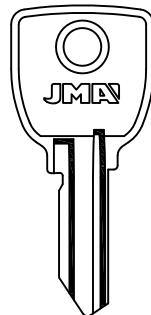
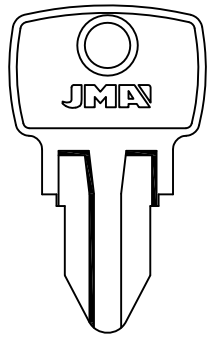









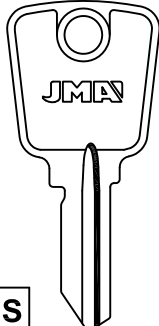
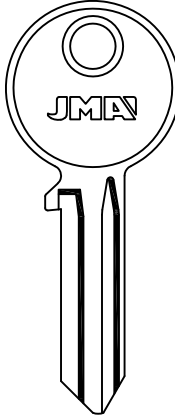
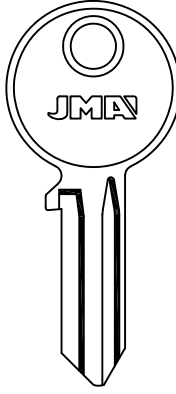
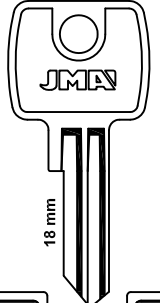

**PARA-FOR:**

- LOB (PL)
- LOCK (MEX)
- LOCKWOOD (USA)
- LOGO (I)
- L.&F. (GB)

| LOB  |   |  | LOCK   |  |
|--|---|--|--|--|
|   |                |    |                         |  |
|  PP<br>LB-2D<br><br> LB-4D |  PP<br>LB-2D.P |  LB-3<br> LB-3D |  LOC-1D<br>ACE.<br>LAT. |  |
| BRICARD-EXPRES-REDY-YETI   |   |  |  |  |

| LOCKWOOD  |   |  |  |  |
|---|---|--|--|--|
|   |   |                 |                        |              |
|  0 AL 9 A<br>LWO-1<br> LWO-1D |  0 AL 9 A<br>LWO-2<br> LWO-2D |  24A<br>LWO-7D |  CL.. 1-1000<br>LWO-8 |  N<br>LWO-9 |
| GAINSBOROUGH  |   |  |  | LEN-LOK  |

| LOCKWOOD   | LOGO  |  | L. & F.   |
|--|---|--|---|
|   |    |    |    |
| AUS  | ALU.  |  | 18 mm   |
|  ...151-250<br>L...1-960<br>...1-960<br>LWO-26D |  LO-1I<br> LO-1D<br> LO-3D |  LO-2I<br> LO-2D<br> LO-4D |  90...1-200<br>...1-400<br>91...201-275<br>GH...1-4000<br>SS...1-400<br>91...276-350<br>LF-1I<br> LF-1D |
| LEN-LOK  | CISA  | CISA   | CEM-EURO LOCKS-UNION  |



## LOWE & FLETCHER

PARA-FOR:

L.&F. (GB)

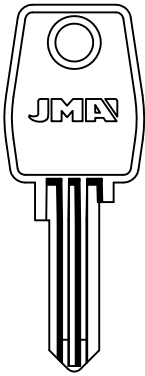

95001-97000  
97001-99000



LF-2

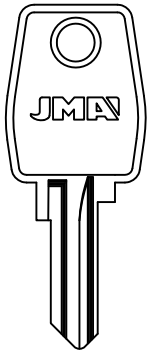

LF-4I



....  
70001-71000  
M....  
70001-71000



LF-5



LF-5D

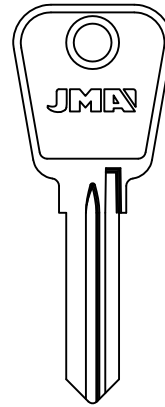

....  
66001-67200



LF-7

.....  
81001-87000



LF-7D

FORD EUROPA



LF-12



LF-12D

BICICLETTA CYCLES

DOBLE SAFE-EURO LOCKS

EURO LOCKS

TELFORD

## LOWE & FLETCHER

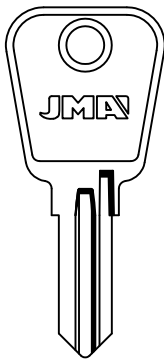

93...201-400  
.....93901-94000



LF-8



LF-8D

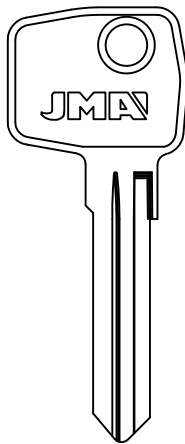

LF-10

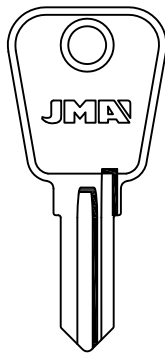

93...201-400  
.....93901-94000



LF-13



LF-13D

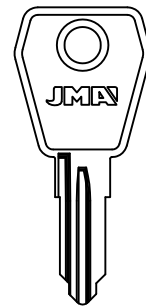

LF-14D

EURO LOCKS-MIBRA-UTZ

EURO LOCKS

MIBRA-UTZ

EURO LOCKS

## LOWE & FLETCHER

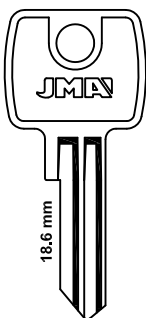

18.6 mm



60... 001-200  
60... 001-200  
90... 001-200  
...1-400  
GHM...1-155  
M...1-400  
RV...1-400  
RVM...1-400  
SP...1-400  
99...1-400



LF-15

FFE  
001-100



LF-17

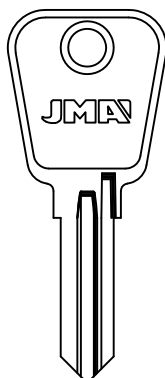

LF-16

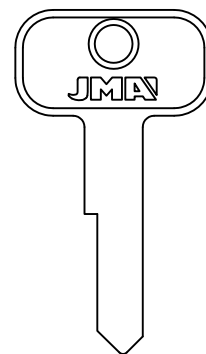

LF-18D

CEM-EURO LOCKS-ULTRA-UNION

**JMA**<sup>®</sup>

Copyright by Alejandro Altuna S.A. 2014



ATENCIÓN: Concerniente a las marcas y denominaciones comerciales ver nota en índice.  
ATTENTION: Concerning the marks and commercial denominations see note in index.  
ATTENTION: Concernant les marques et dénominations commerciales voir la note dans l'index.  
ACHTUNG: Beziehen auf die marke und handelsname sehen sie die notiz im index.

PARA-FOR:

L.&F. (GB)

LOWE & FLETCHER

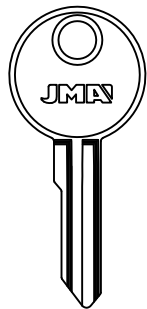

LF-19

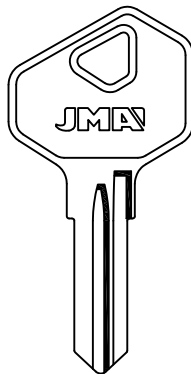

LF-20

19...1-420  
....17001-19000  
....7001-9000

LF-20D

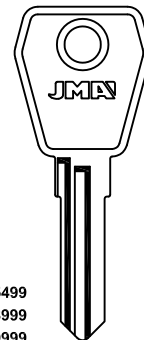

LF-21

....35000-35499  
....78000-78999  
....79000-79999

LF-33D

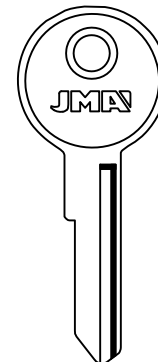

LF-22

LOWE & FLETCHER

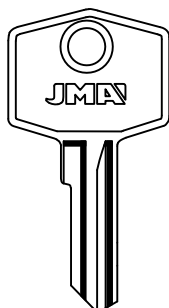

LF-23

ULTRA

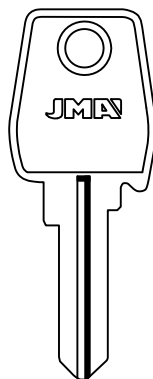

LF-24

DOBLE SAFE-EURO LOCKS

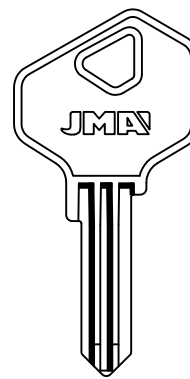

LF-25

V..1-88  
14001-14088

LF-40

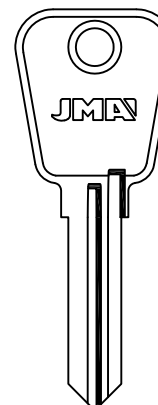

LF-26

LOWE & FLETCHER

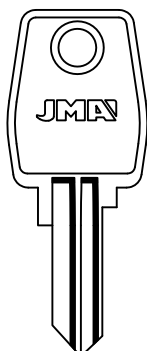

LF-27

EURO LOCKS

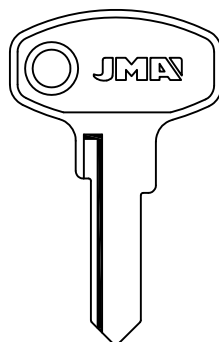

LF-28

EURO LOCKS

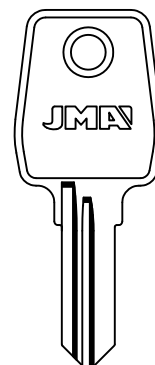

93...401-900  
....90901-90975

LF-29D

EURO LOCKS

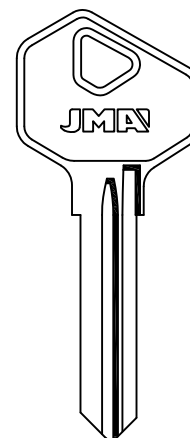

09...1-900  
29...1-478

LF-30



## LOWE & FLETCHER

## PARA-FOR:

L.&F. (GB)

LT (PRC)

LUCKY (RC)

LUMA (E)

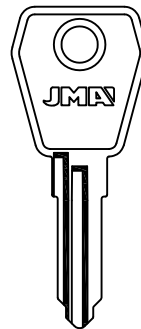
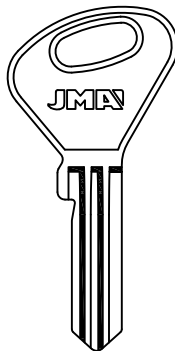
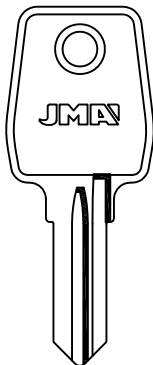
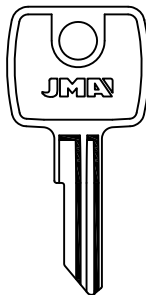
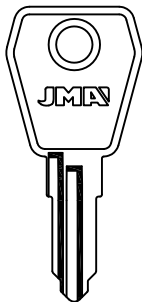

LF-31

LF-34

R...201-600  
...9001-9494

LF-35

LF-36

LF-37D

LF-38D

## LOWE & FLETCHER

## LT

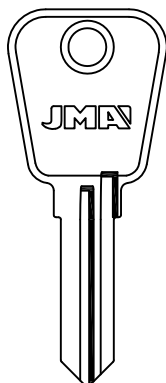

LF-41

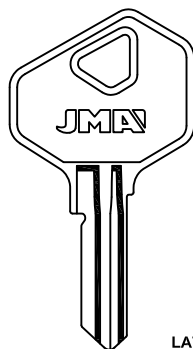

LAT.

92...601-800

LF-44

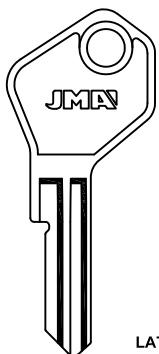

LAT.

92...1-400  
60...001-400  
...1-400  
...RV1  
...ES1  
91...201-350  
M...1-400

LF-45

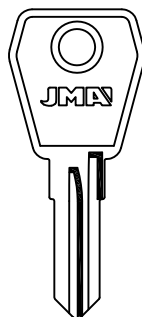

LF-46

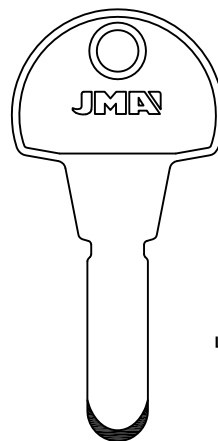

LAT.



LT-1

## LUCKY

## LUMA

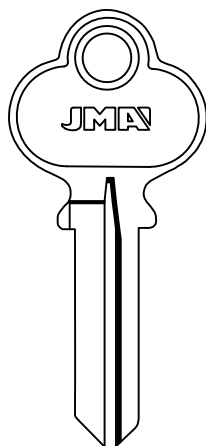

LUC-1D

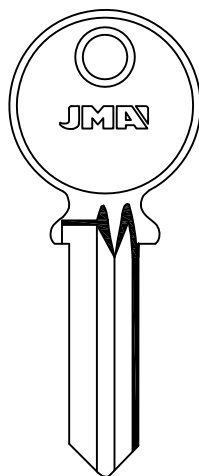

LUC-2

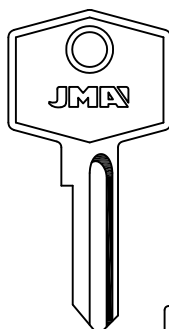

A1101-A1112

LUMA-1I

B3301-B3312

LUMA-2I

A2201-A2212

LUMA-1D

B4401-B4412

LUMA-2D

C5501-A5512

LUMA-3I

LUMA-4I

C6601-C6612

LUMA-3D

LUMA-4D

BASTA

**JMA**<sup>®</sup>

Copyright by Alejandro Altuna S.A. 2014



ATENCIÓN: Concerniente a las marcas y denominaciones comerciales ver nota en índice.











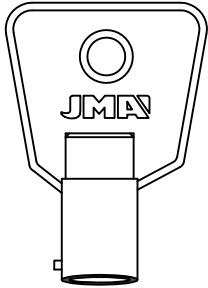
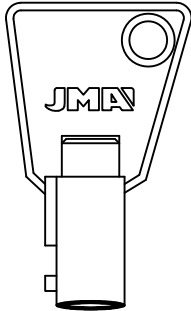
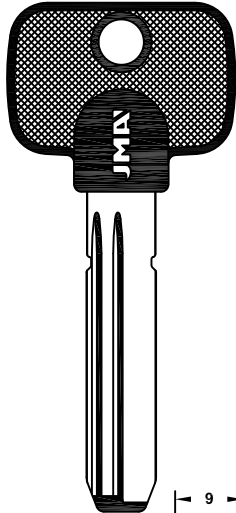
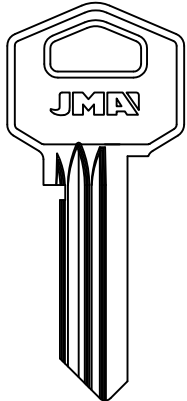

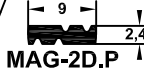

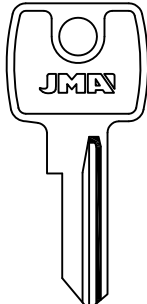
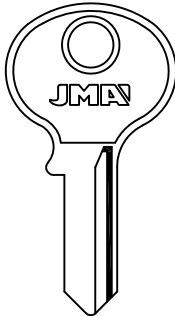
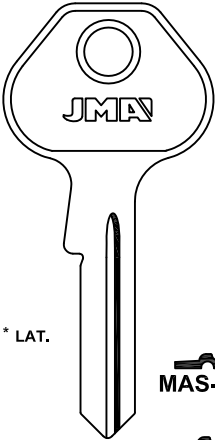
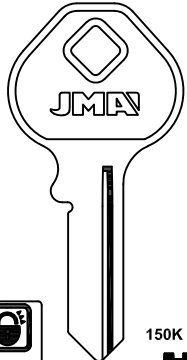







ATTENTION: Concerning the marks and commercial denominations see note in index.

ATTENTION: Concernant les marques et dénominations commerciales voir la note dans l'index.

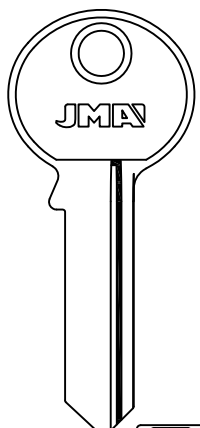
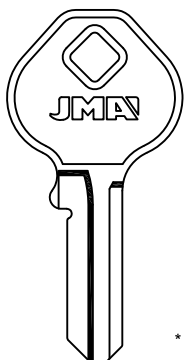
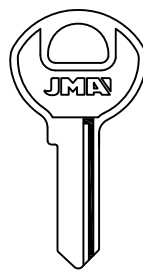
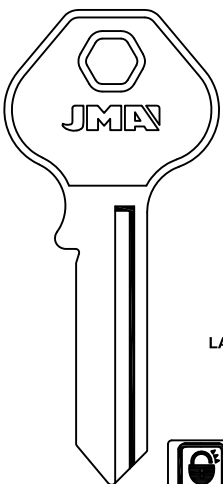
ACHTUNG: Beziehen auf die marke und handelsname sehen sie die notiz im index.

**PARA-FOR:**

- LYF (E)
- MAGNUM (GB)
- MARIANI (I)
- MARQUES (P)
- MASTER (USA)

| LYF   |   | MAGNUM  | MARIANI   |
|---|---|---|---|
|    |    |     |    |
| LAT.  | LAT.  | ALP.  |   |
|    |    |    |    |
| LYF-1T  | LYF-2T  | MAG-2D.P  | MA-5D   |
| MARQUES   |   | MASTER  |   |
|   |   |    |   |
|   |   | * LAT.  |   |
|  |  |  |  |
| MQ-11   | MQ-1D   | MAS-2D  | MAS-3D  |
|  |  |  |  |
| MAS-1   | MAS-1D  | MAS-22D   | MAS-11  |
|   |   |  |  |
|   |   | 7000 * MAS-24D  | MAS-11D   |
|   |   |   |  |
|   |   |   | MAS-12D   |
| MASTER  |   |   |   |
|  |  |  |  |
|   | * LAT.  | LAT.  | LAT.  |
|  |  |  |  |
| MAS-4D  | * MAS-5D  | MAS-7   | MAS-8   |
|   |  |  |   |
|   | MAS-6   | MAS-7D  |   |





**MASTER**

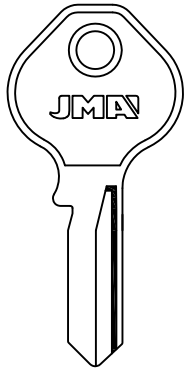

LAT.

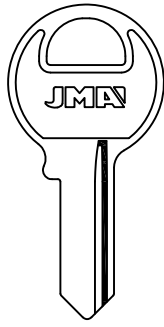

LAT.

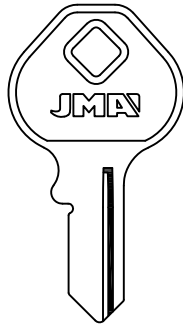

JMA



MAS-13D



LAT.



MAS-15.P  
7.2  
1.95

MAS-9

MAS-9D

MAS-10

MAS-10D

**MASTER**

**MASTER LOCK**

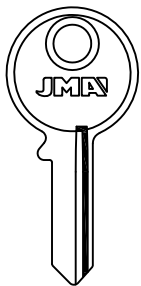

LAT.

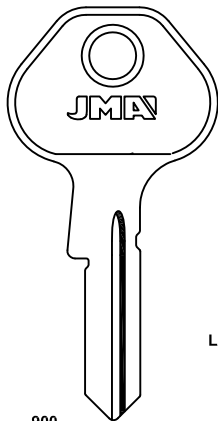

LAT.

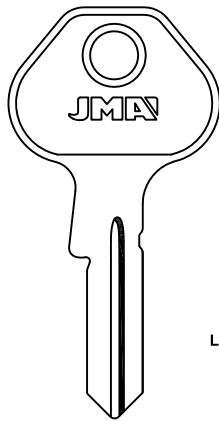

LAT.

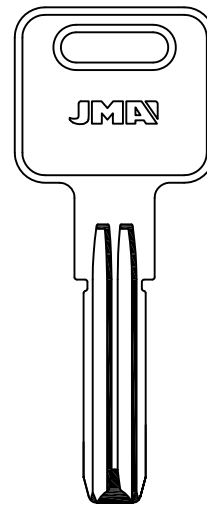

LAT.

900  
MAS-19

6000  
MAS-18D

6000B  
MAS-29D

MASL-1

MAS-17

MAS-17D

**MAXUS**

**MCL**

**MCM**

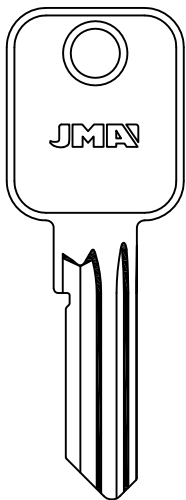

MXS-1

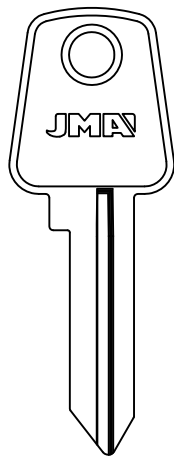

MCL-1D

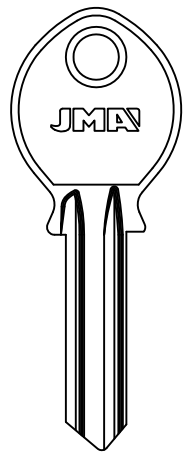

MCM-1

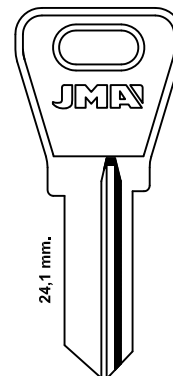

24,1 mm.

MCM-21

MCM-2D

**PARA-FOR:**

MASTER (USA)

MASTER LOCK (TJ)

MAXUS (UA)

MCL (RUS)

MCM (E)



PARA-FOR:

MCM (E)

MCM

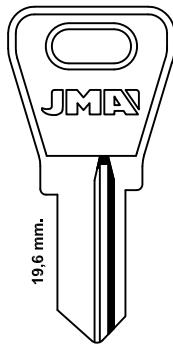

MCM-3I

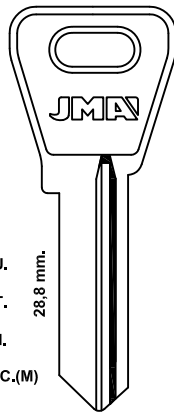

\* ALU.  
\* LAT.  
\* FSH.  
\*\* MTIC.(M)

\* MCM-4I

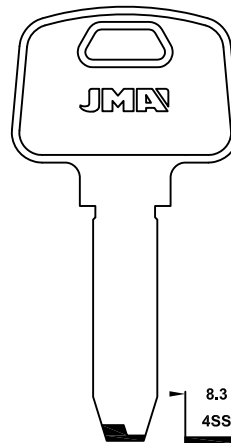

MCM-4D \*\*

MCM-4EC

ESAFE-K+K

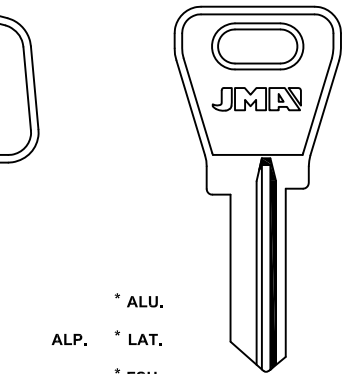

MCM-4SS

MCM-11S

LOB-YETI

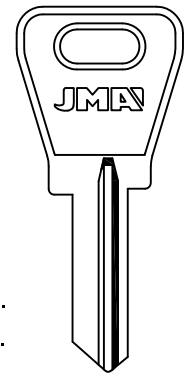

\* ALU.  
\* LAT.  
\* FSH.

MCM-5I

COFER

\* MCM-5D

MCM

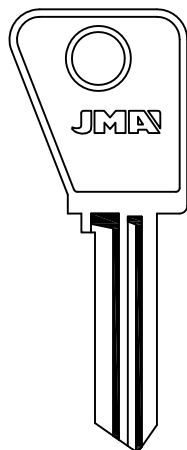

MCM-6

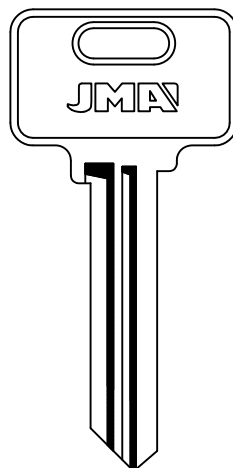

MCM-7

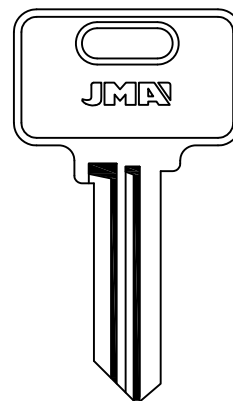

MCM-8

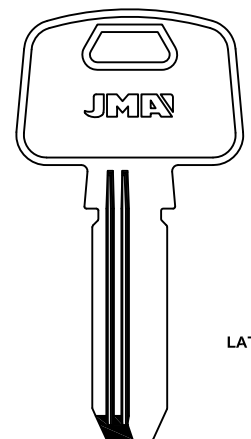

MCM-10

ESAFE-TROMER

LAT.

MCM

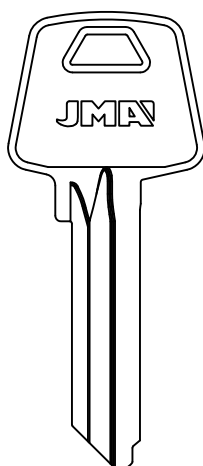

MCM-12D

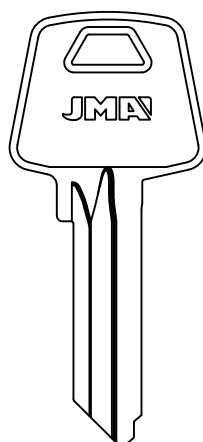

MCM-13D

ALU.  
FSH.

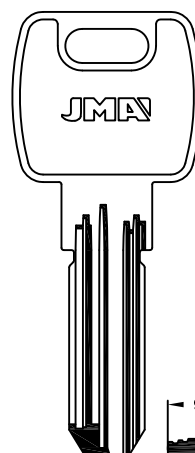

MCM-16

MCM-21D

DIERRE

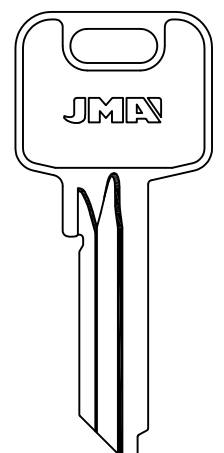

X.....1234567890  
E.....11241-79868  
E-1

MCM-18D



**MCM**

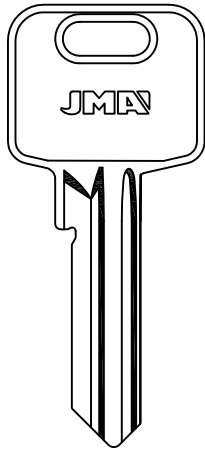

B  
MCM-24B

C  
MCM-24C

D  
MCM-24D

E  
MCM-24E

F  
MCM-24F

MCM-26

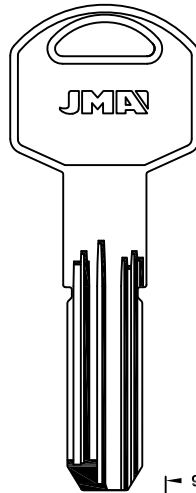

LAT.

9.7  
E8  
2.8  
MCM-27

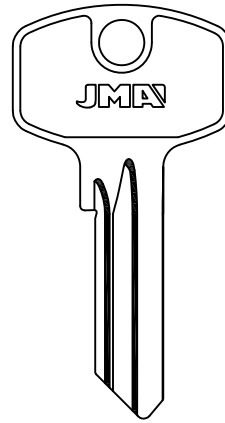

MCM-29D

**PARA-FOR:**

- MCM (E)
- ME-FA (RC)
- MECO (D)
- MELSMETALL (D)

**MCM**

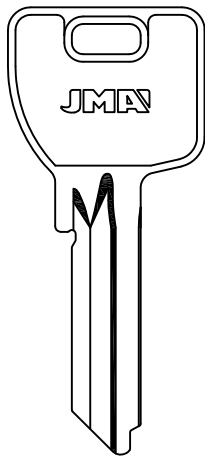

E  
MCM-30D

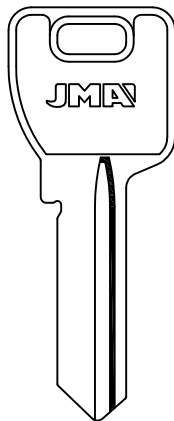

25  
MCM-31

C  
MCM-31D

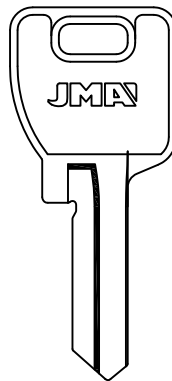

OV  
MCM-32D

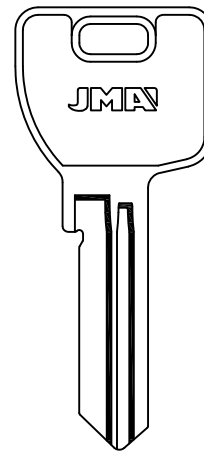

AV  
MCM-33

**MCM**

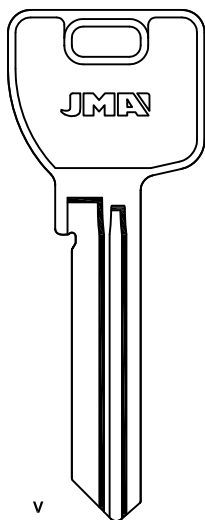

V  
MCM-35

**ME-FA**

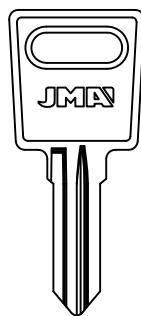

...1-100  
BRA-1  
BRABANTIA-CLAUSOR-CASH BOX  
ELSET

**MECO**

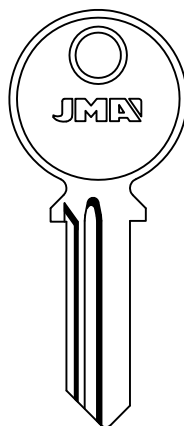

MEC-5D

**MELSMETALL**

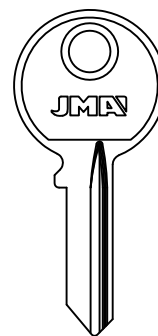

MEL-1

MEL-4

MEL-4D



**PARA-FOR:**  
 MELSMETALL (D)  
 MERONI (I)

**MELSMETALL**

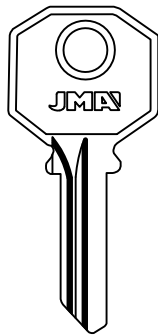

MEL-2D

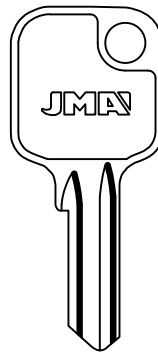

MEL-3

HBC



MEL-5.P

SECURIKEY

**MERONI**

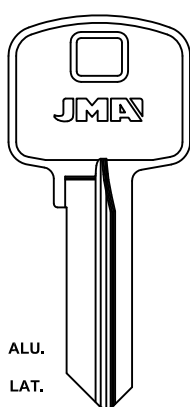

ALU.  
LAT.

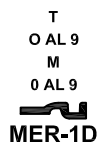

MER-1D

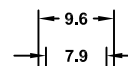
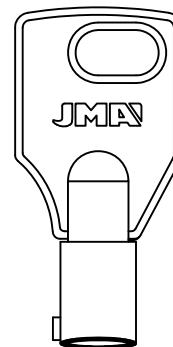
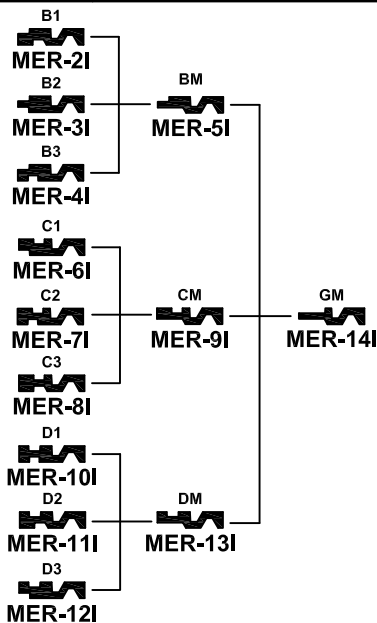

MER-1T

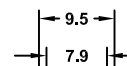
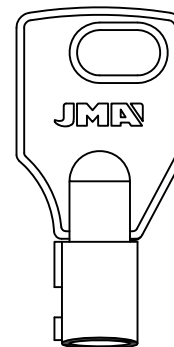

MER-3T

**MERONI**

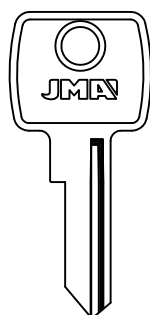

MER-15

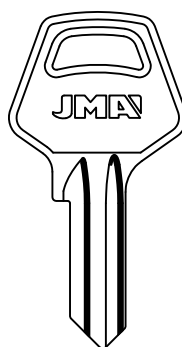

MER-16

LAMA

MER-16D

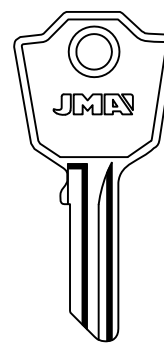

MER-17

LAMA

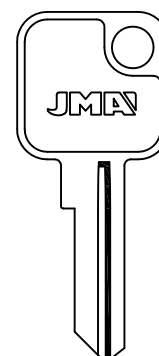

MER-18

PREMI-APRI

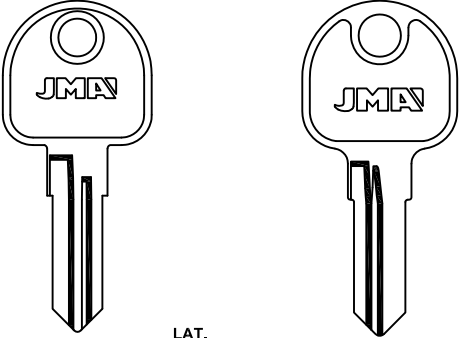
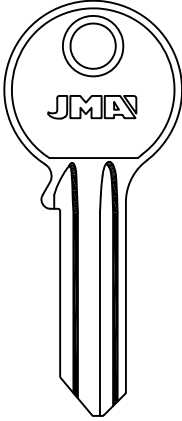
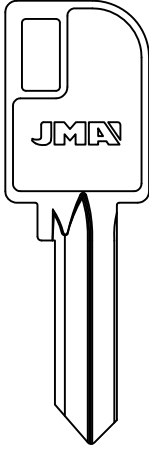
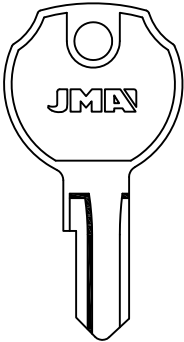
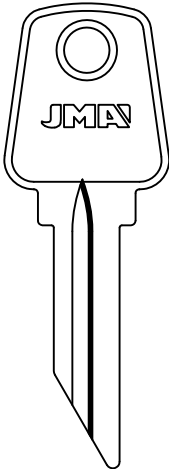
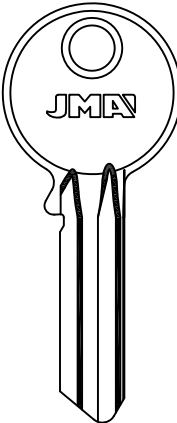
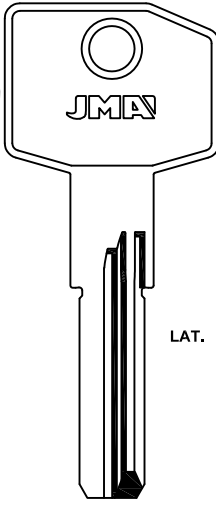
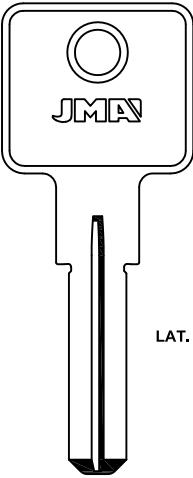
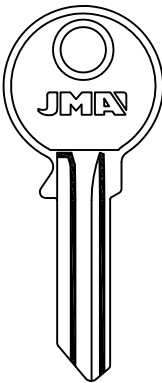
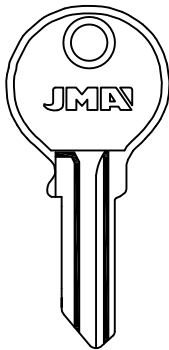
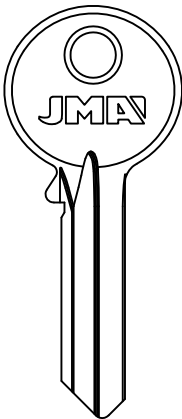
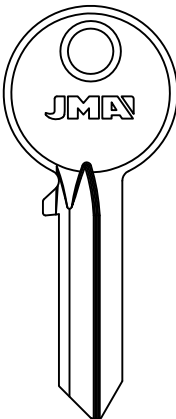

| MERONI   |  | METAL   | METALUX  |   |
|--|--|---|--|---|
|  <p>LAT.</p> <p>CC<br/>MER-20D</p> <p>CD<br/>MER-21D</p> <p>MER-19D</p> |  |  <p>MTL-1    MTL-1D</p>  |  <p>MET-2D</p> <p>CAS-CISMA</p>         |   |
| METEOR   | METIZ  | MG (MONTI)  |  |   |
|  <p>B...1-600<br/>G...1-600</p> <p>MTO-1</p>                           |  <p>MEZ-1D</p> |  <p>MGA-1    MGA-1D</p> |  <p>LAT.</p> <p>MGA-2</p> <p>TROMER</p> |  <p>LAT.</p> <p>MGA-3</p> |
| MICHEL-SEAT  |  | MILA  |  |   |
|   |  <p>LAT.</p>  |                        |                                       |   |
| <p>MCH-1    MCH-1D    MCH-2    MCH-2D</p> <p>OMR-POTENT                      AM-POTENT</p>   |  | <p>MI-1D</p>  | <p>MI-2D</p>   |   |











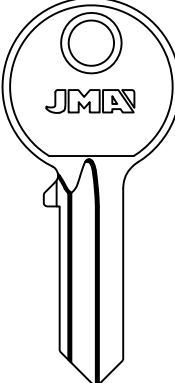
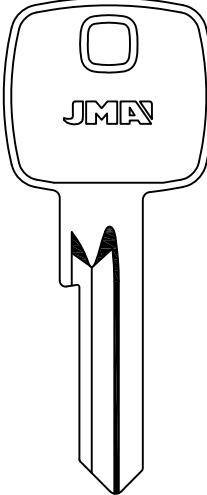
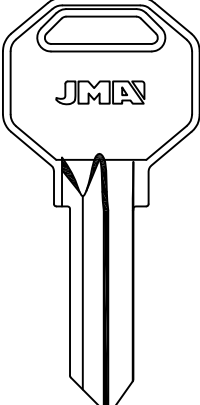
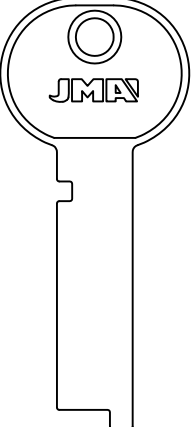

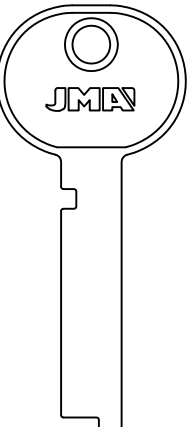
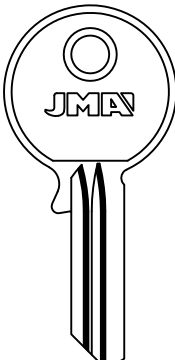
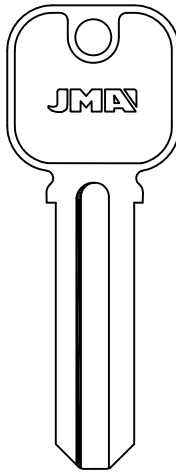

**PARA-FOR:**

- MERONI (I)
- METAL (BG)
- METALUX (F)
- METEOR (D)
- METIZ (RUS)
- MG MONTI (I)
- MICHEL-SEAT (I)
- MILA (DK)

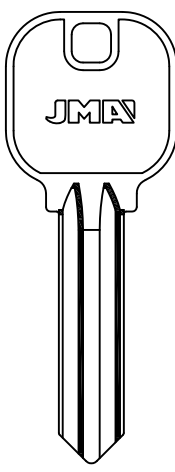
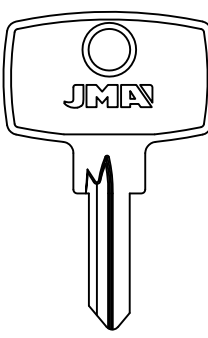

**PARA-FOR:**

- MILA (DK)
- MILES (RUS)
- MING-TAY (RC)
- MIWA (J)
- MLM (F)

| MILA   |  |   | MILES   |  |  |
|--|--|---|---|--|--|
|             |           |             |              |  |  |
| <br>MI-3D   | <br>MI-4D | <br>MI-5D  | <br>MIL-1    |  |  |
|  |  |   | TRINITY   |  |  |
| MILES  |  | MING-TAY  |   | MIWA   |  |
|            |  |             |   |             |  |
| <br>MIL-2 |  | <br>MIN-1D |   | LAT.   |  |
|  |  |   |   | <br>MIW-1 |  |
|  |  |   |   | <br>MIW-2 |  |
| MIWA   |  |   | MLM   |  |  |
|           |  |   |             |  |  |
| <br>MIW-3 |  |   | <br>MLM-1D |  |  |
| <br>MIW-4 |  |   | <br>MLM-5  |  |  |
|  |  |   | <br>MLM-5D |  |  |
|  |  |   | DOM-STUV  |  |  |
|  |  |   | DOM-STUV  |  |  |

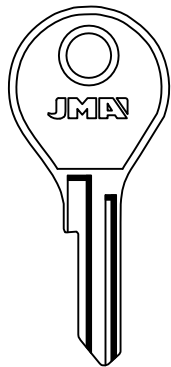

**MLM****MLM-3**

DOM-STUV

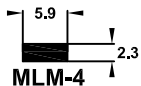
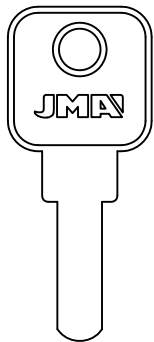
**MLM-4**

LAT.

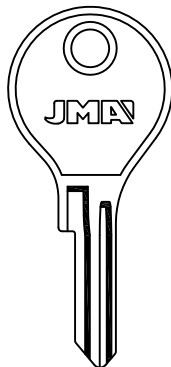
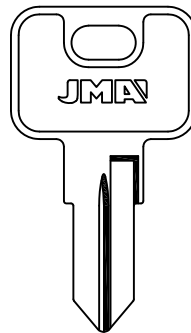
**MLM-6****MLM-7****MOBELLA****MBL-1****MBL-1D****PARA-FOR:**

MLM (F)

MOBELLA (S)

MOGILEV (RUS)

MON (E)

MONOBLOC (F)

MOSRENTGUEN (RUS)

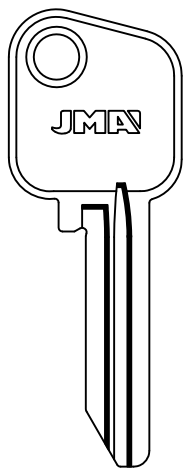
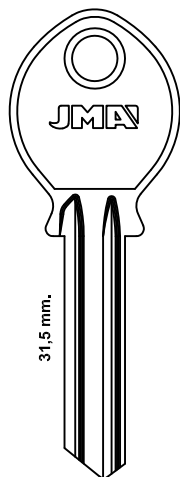
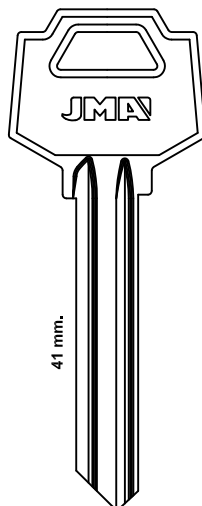
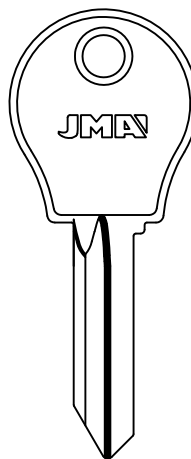



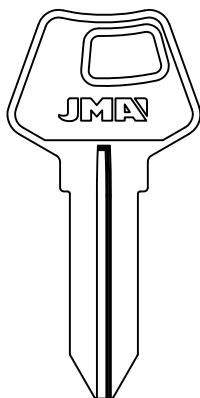
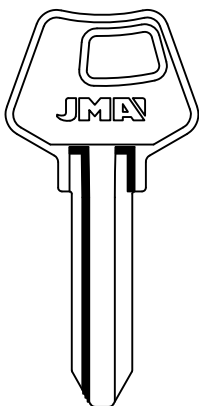
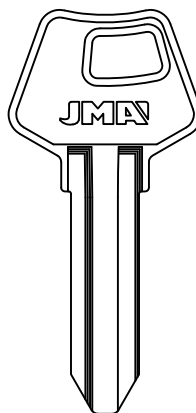





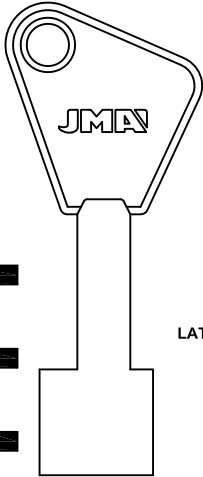



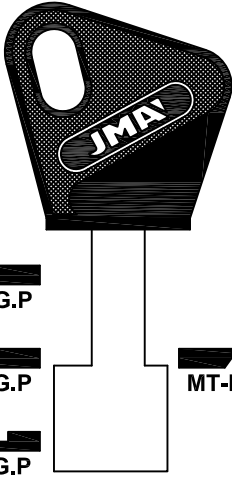



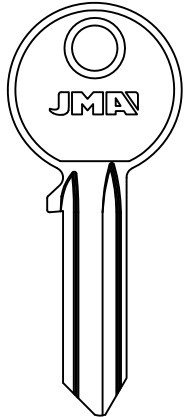

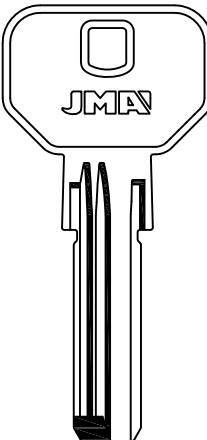

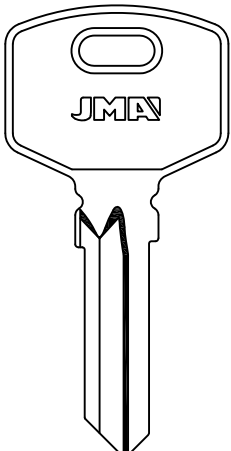

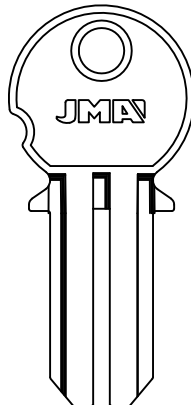
**MOGILEV****MOG-1D****MON****MON-1I****MON-1D****MON-2I****MON-2D****MONOBLOC****MNO-1D**

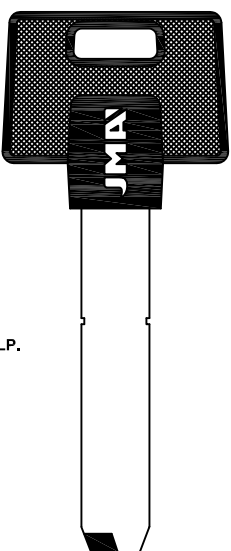
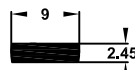
FO

**MOSRENTGUEN****MR-1****MR-2****MR-3**

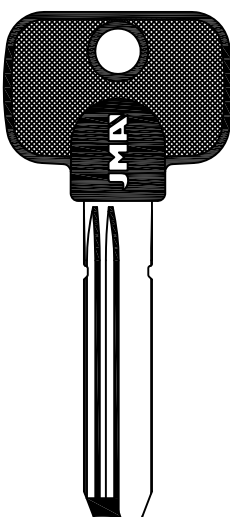
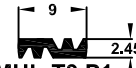
**PARA-FOR:**

- MOTTURA (I)
- M.P. PLODARI (I)
- MSM
- MSV (P)
- MUL.T.LOCK (IL)

| MOTTURA   |   | M.P. PLODARI  |
|---|---|---|
|  <p>LAT.</p>  MT-AG<br> MT-CG<br> MT-EG<br> MT-GG  |  <p>LAT.</p>  MT-AG.P<br> MT-CG.P<br> MT-EG.P<br> MT-GG.P   |  <p>LAT.</p>  MP-1I<br> MP-1D      |
| MSM   |   | MSV   |
|  <p>LAT.</p>  <p>8.7<br/>2.3<br/>MSM-1D</p>  |  <p>LAT.</p>  MSM-2D   |  <p>LAT.</p>  MSV-1<br> MSV-2 |
| MUL.T.LOCK  |   |   |
|  <p>LAT.</p>  <p>9<br/>2.45<br/>MUL-T2.P</p>  MUL-T3.P<br> MUL-T4.P<br> MUL-T5.P<br> MUL-T7.P |  <p>LAT.</p>  <p>9<br/>2.45<br/>MUL-T3.P1</p> <p>64</p>  MUL-T8.P1<br> MUL-T9.P1<br><p>JUNIOR</p>  MUL-T11.P1 | <p>GAMMA</p>  |





**MUL.T.LOCK**

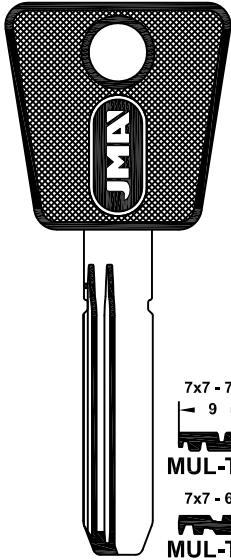
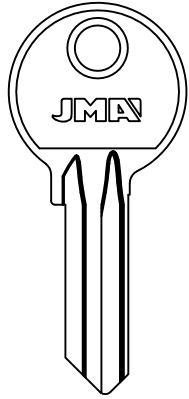

ALP.

MUL-T6 MUL-T6D

MUL-T10.P  
MUL-T16.P

**NATIONAL CABINET**

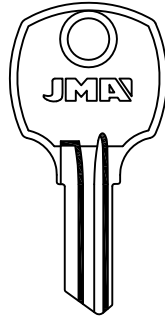

LAT.

NTC-6

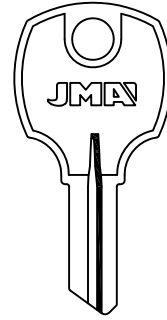

LAT.

NTC-10D

**PARA-FOR:**

- MUL.T.LOCK (IL)
- NATIONAL CABINET (USA)
- NOVA (D)
- OCARIZ (E)
- OCTAVO M. (RUS)
- OFITA (E)
- OJMAR (E)

**NOVA**



NO-1

ABUS-TOP

**OCARIZ**

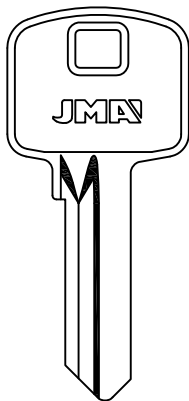

KL  
OCA-1D  
KR  
OCA-2D

**OCTAVO M.**

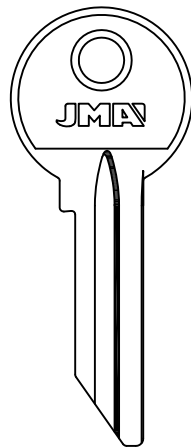

8M-1D

**OFITA**

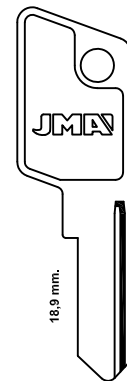

OF-1

**OFITA**

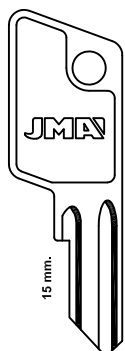

OF-2

**OJMAR**

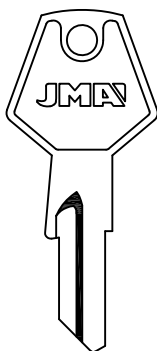

OJ-1D

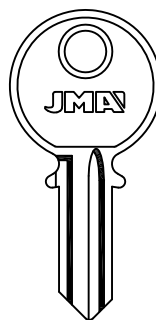

OJ-2I

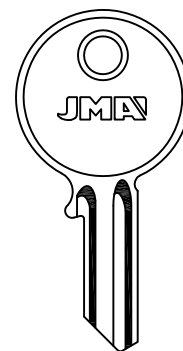

OJ-3I OJ-3D

OJ-7I



**PARA-FOR:**

OJMAR (E)

OLIVA (I)

**OJMAR**

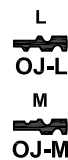
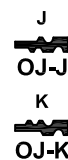
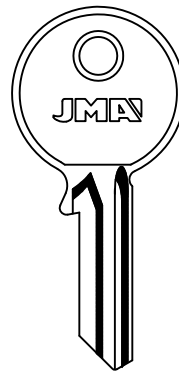
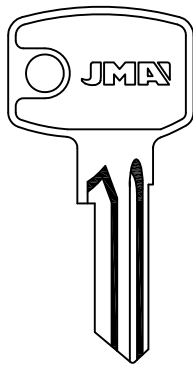
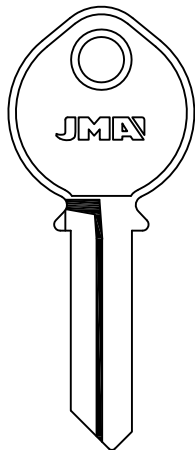

**OJMAR**

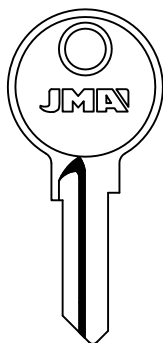

HERO-KEMEN-RS

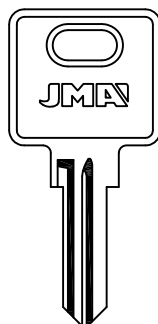

BURG-HRG-ISKU-KEMEN-MOFLEX-SISO-STUMPF METALL

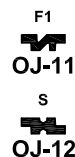
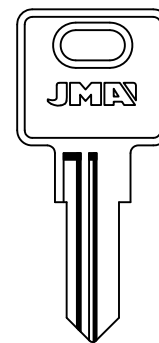

BURG

**OJMAR**

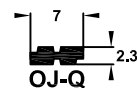
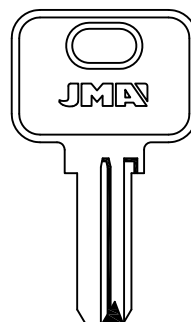
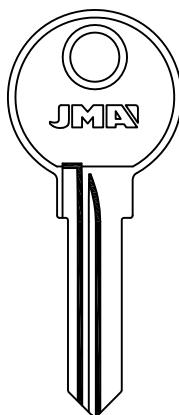
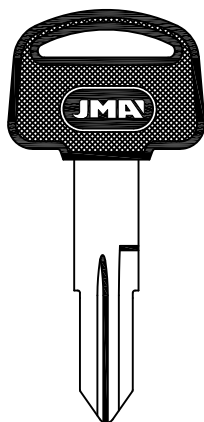

ALP.

**OLIVA**

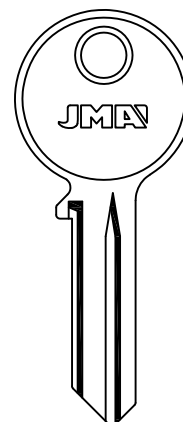



FERMABLOCK-PB-PREFER

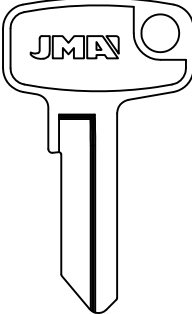
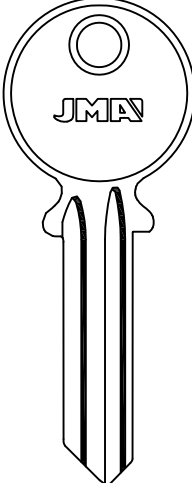
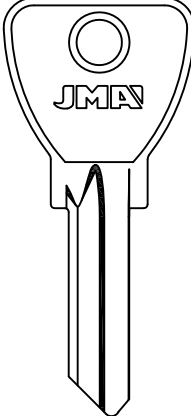
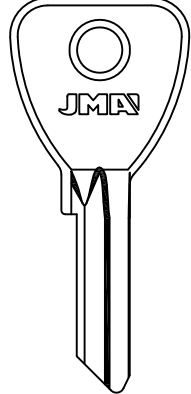

| OLIVETTI   | OMA  | O MEC  |  |
|--|--|--|--|
|  <p data-bbox="159 638 239 683"><b>OLIV-1</b></p> |  <p data-bbox="462 638 542 683"><b>OA-1</b></p> <p data-bbox="470 694 534 716">C.A.R.S.</p> |  <p data-bbox="829 638 909 683"><b>OMC-1D</b></p> |  <p data-bbox="1133 638 1212 683"><b>OMC-2D</b></p> |

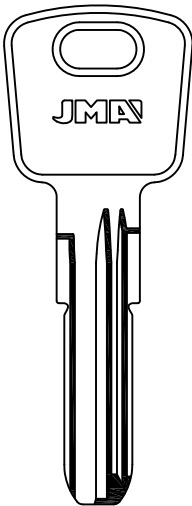
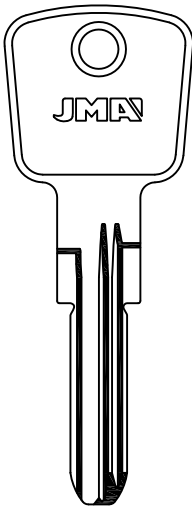
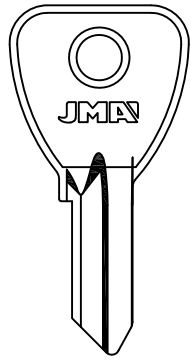
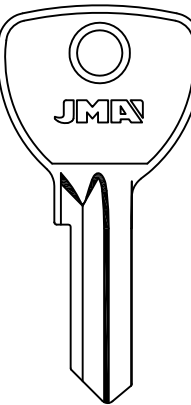
**PARA-FOR:**  
 OLIVETTI (I)  
 OMA (I)  
 O MEC (I)  
 OMIV (I)  
 O.M.R. (I)  
 ORDO (F)  
 ORION-NOVOX  
 (F)

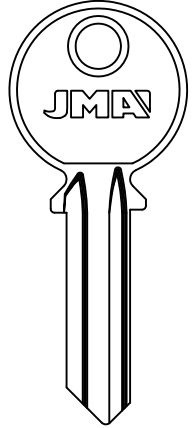
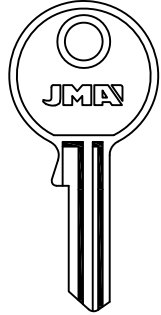

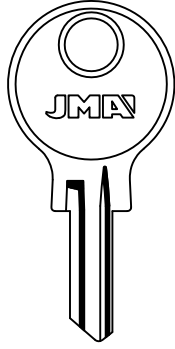
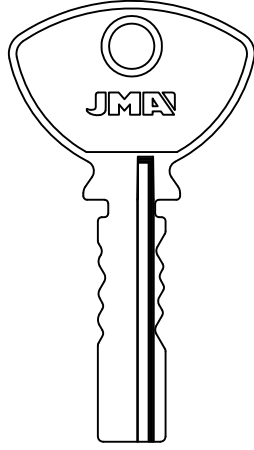







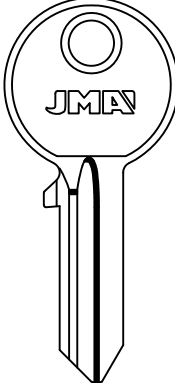
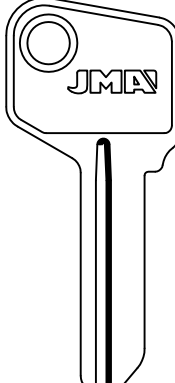
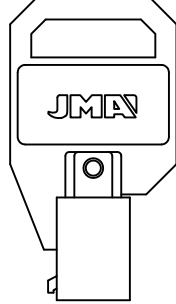
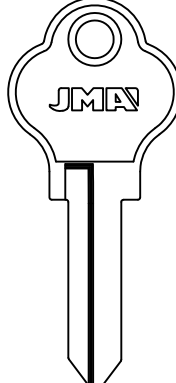

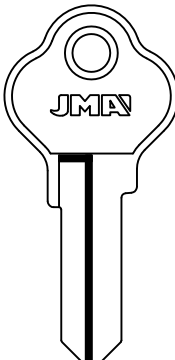
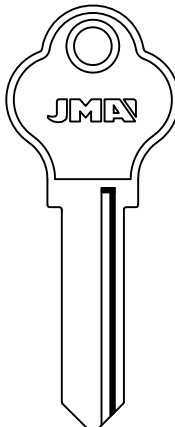
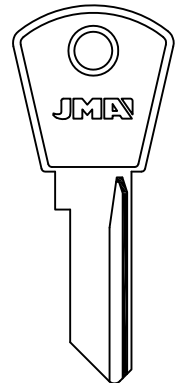
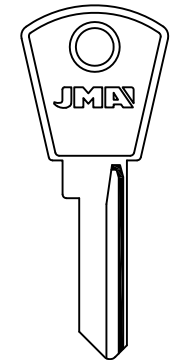

| O MEC  |  |   |   |
|--|--|---|---|
|  <p data-bbox="159 1332 239 1377"><b>OMC-3</b></p> <p data-bbox="167 1377 231 1400">SANTOS</p> |  <p data-bbox="462 1332 542 1377"><b>OMC-4</b></p> |  <p data-bbox="829 1332 909 1377"><b>OMC-5D</b></p> |  <p data-bbox="1133 1332 1212 1377"><b>OMC-6D</b></p> |

| OMIV   | O.M.R.  | ORDO  | ORION-NOVOX   |
|--|---|---|---|
|  <p data-bbox="95 1993 167 2038"><b>OMI-1</b></p> <p data-bbox="223 1993 295 2038"><b>OMI-1D</b></p> <p data-bbox="167 2049 231 2072">CIB-STV</p> |   <p data-bbox="470 1993 534 2038"><b>OM-1</b></p> <p data-bbox="446 2049 558 2072">MICHEL SEAT</p> |  <p data-bbox="710 1993 774 2038"><b>OR-1I</b></p> |  <p data-bbox="1005 1993 1077 2038"><b>ON-1I</b></p> <p data-bbox="1141 1993 1212 2038"><b>ON-1D</b></p> <p data-bbox="1061 2049 1157 2072">DECAEUX</p> |

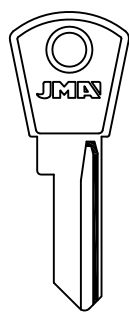
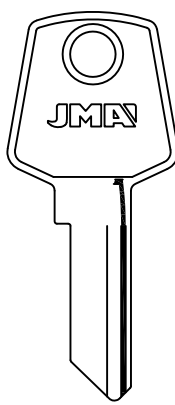
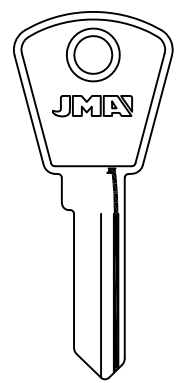
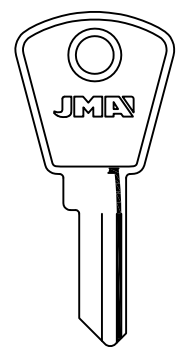

**PARA-FOR:**

- ORO (IL)
- ORSHA (RUS)
- P&C I. (USA)
- PADO (BR)
- PAPAIZ (BR)

| ORO   | ORSHA   | P&C I.   | PADO  |
|---|---|--|---|
|                      |                            |              |                            |
| <br>ORO-1D           | <br>ORK-1D                 | <br>PCI-1T  | <br>PAD-1D                 |
| PADO  |   | PAPAIZ   |   |
|                     |                           |             |                           |
| <br>PAD-2D         | <br>PAD-3                | <br>PAD-3D  | <br>45-50-60-70<br>PAP-1 |
|   |   |  | <br>35<br>PAP-2          |
| PAPAIZ  |   |  |   |
|                    |                          |            |                          |
| <br>25-30<br>PAP-3 | <br>45-50-60-70<br>PAP-4 | <br>PAP-5 | <br>PAP-6                |



P.C.

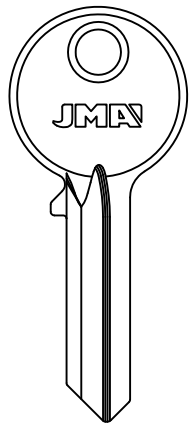

1 AL 5  
PC-1D

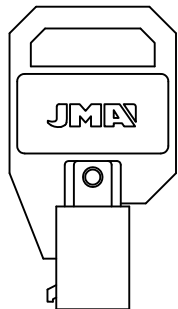

8,04 9,6  
PC-1T

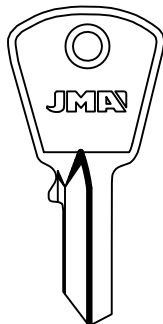

...1 AL 5  
PC-2D

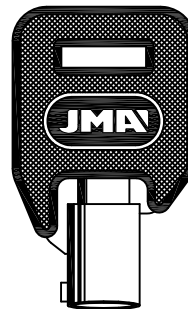

8,04 9,6  
PC-3T.P

ETNA-FEB-FPB-FRAL-SANTOS

PARA-FOR:

P.C. (I)

PENZMASH  
(RUS)

PETROZAVODSK  
(RUS)

PFAFFENHAIN  
(D)

PENZMASH

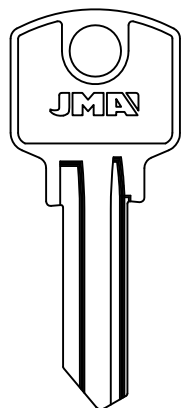

PEN-1 PEN-1D

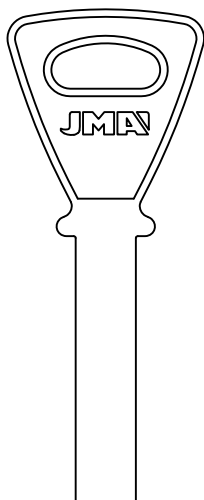

PEN-2

PETROZAVODSK

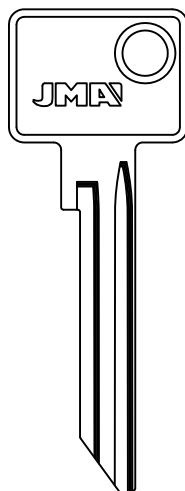

PET-1

PFAFFENHAIN

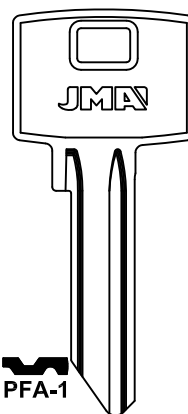

PFA-1  
KH  
PFA-2  
PFA-5

PFAFFENHAIN

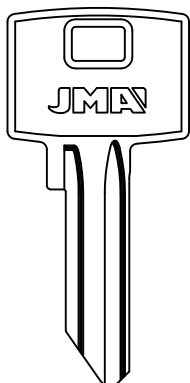

L  
PFA-3

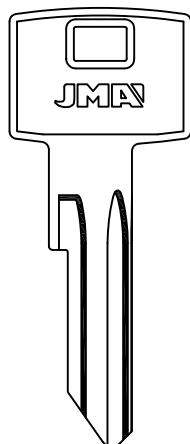

PFA-4

A21  
PFA-10D  
A22  
PFA-11D  
A23  
PFA-12D

EA  
PFA-13D  
EB  
PFA-14D  
EH  
PFA-15D  
EN  
PFA-16D  
RF  
PFA-17D  
RG  
PFA-18D

T21 AL T26-T28  
T31 AL T42  
T44 AL T46  
T51-T54-T65  
T85-T86-T91  
PFA-22 PFA-22D



**PARA-FOR:**

PFAFFENHAIN  
(D)

PHILLIPS (MEX)











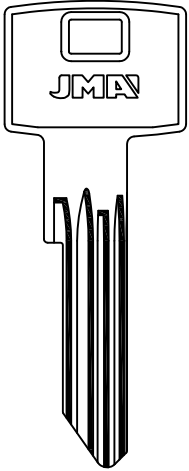
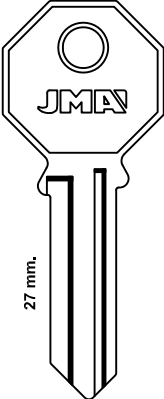
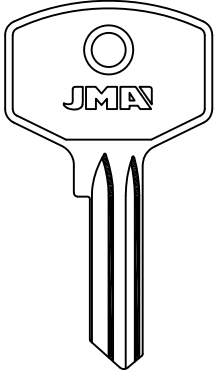







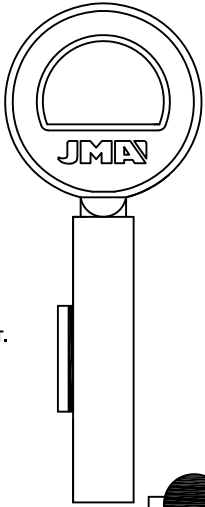
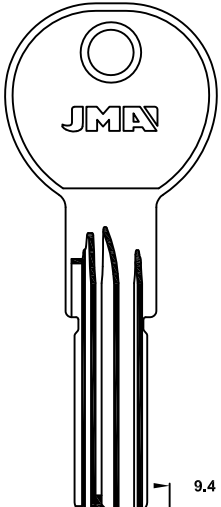

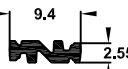
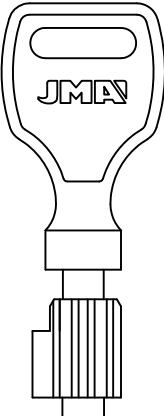
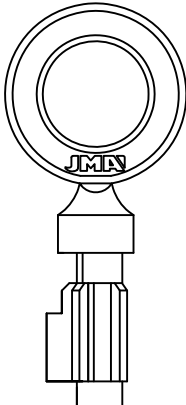

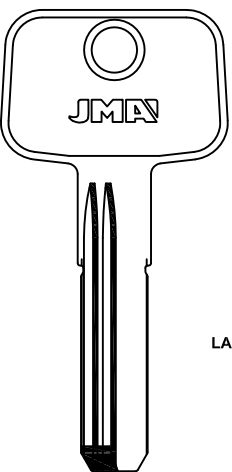
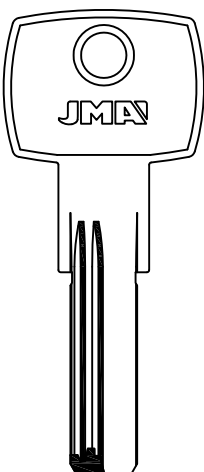

PHOENIX (GB)

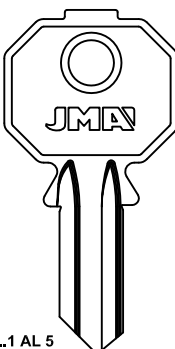
PICARD (F)

POLLUX (F)

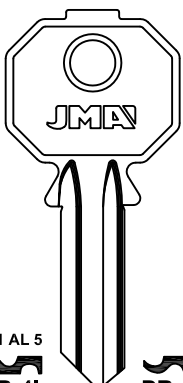
POTENT (I)

PREFER (I)

| PFAFFENHAIN  |  | PHILLIPS   | PHOENIX   |  |
|--|--|--|---|--|
|   |  |  <p>27 mm.</p>  |    |  |
|  PFA-6  PFA-6D  PFA-21  |  |  PHI-52   |  PHO-1   |  |
|  |  |  |  A21<br>PFA-7D<br> A22<br>PFA-8D<br> A23<br>PFA-9D |  |
| PICARD   |  | POLLUX   |   |  |
|  <p>LAT.</p>  <p>LAT.</p>  PIC-1E  PIC-8D <p>9.4<br/>2.55</p> <p>ISEO</p>          |  |  <p>LAT.</p>  <p>LAT.</p>  POL-3TEC  POL-5TEC  POL-4E  |   |  |
|  |  |  |   |  |
| POTENT   |  | PREFER   |   |  |
|  <p>LAT.</p>  <p>P04.....<br/>1-2-3-4-5-6</p>  PTN-1D <p>8.6<br/>2.4</p>  PTN-2D |  |  <p>...1 AL 5</p>  PR-1  PR-1D  PR-2  PR-3 <p>UNIFOR</p>                                    |   |  |
|  |  |  <p>...1 AL 5</p>  PR-4I  PR-4D  PR-10  PR-11 <p>BLOCUS-CAP-CIB-JIP<br/>PASTORE-PROMO</p> |   |  |



**PREFER**

**PARA-FOR:**

PREFER (I)  
REGAL (GB)  
RENZ (D)

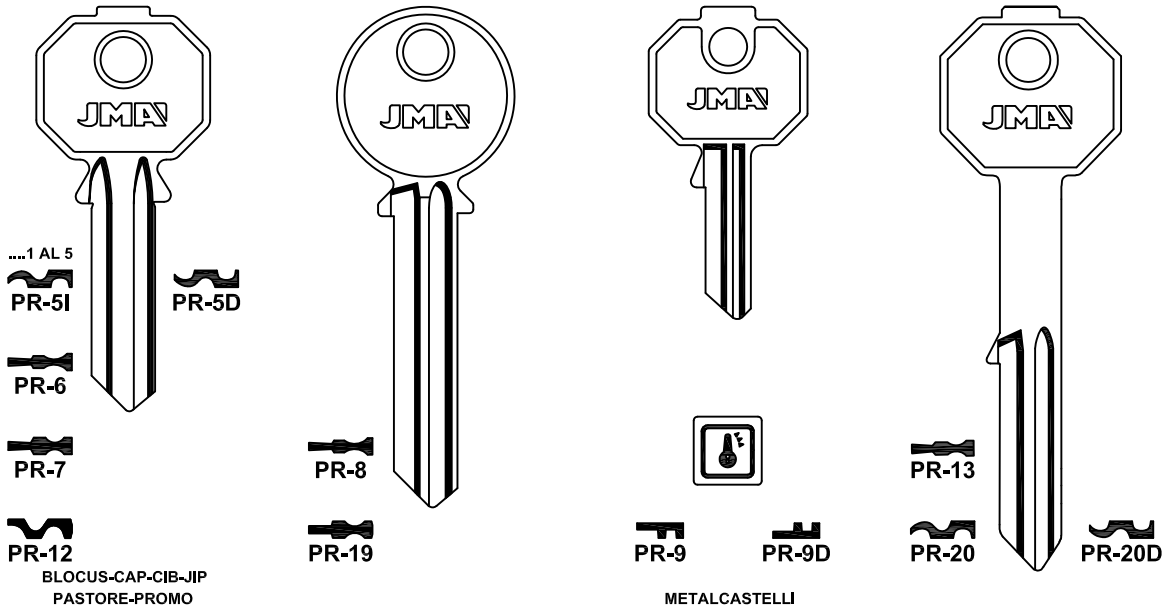

**PREFER**

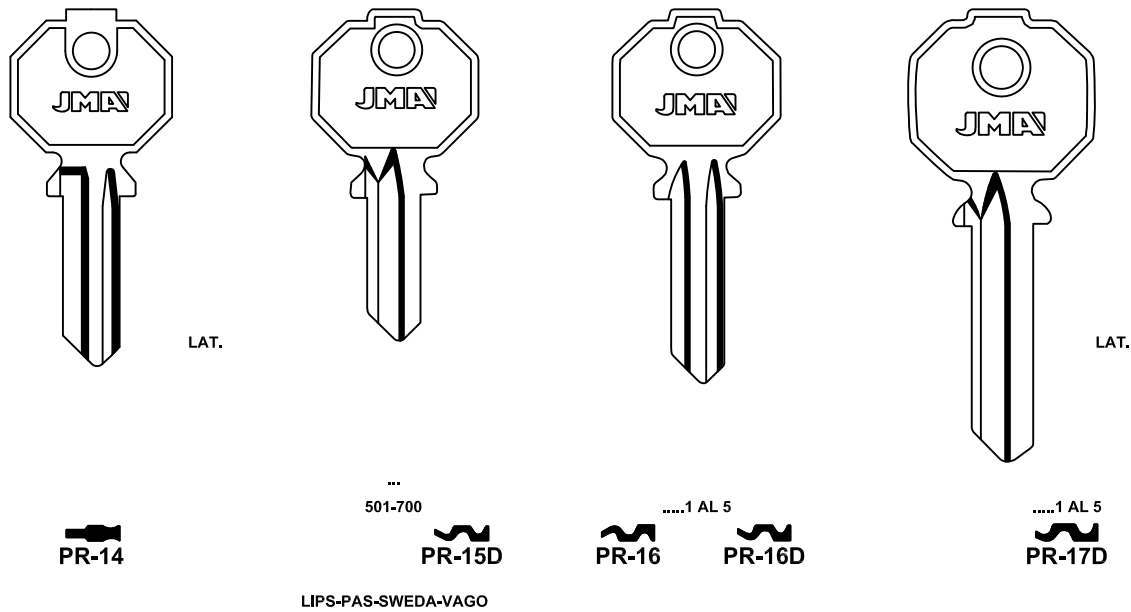

**PREFER**





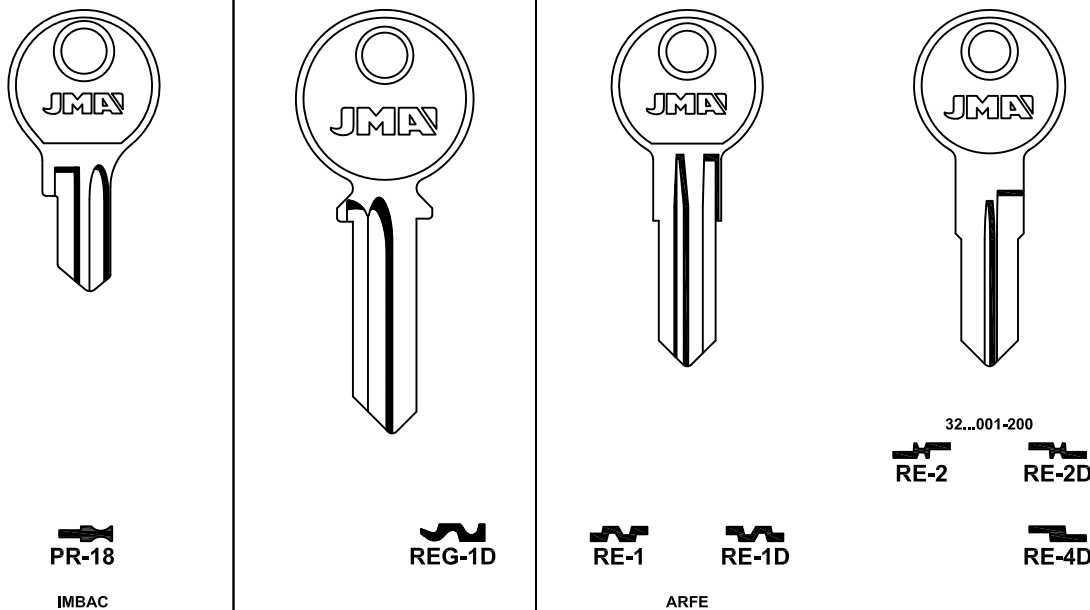





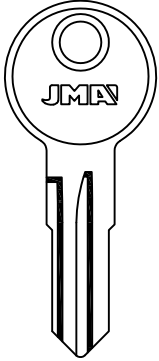
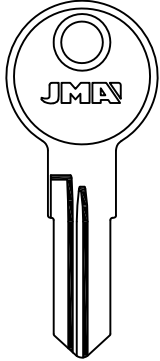
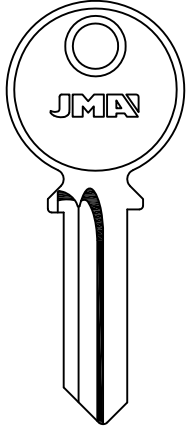
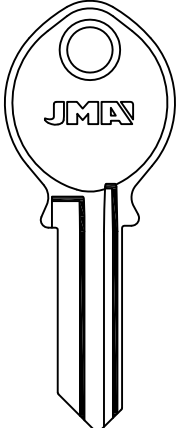





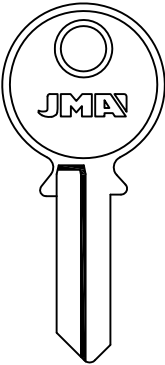
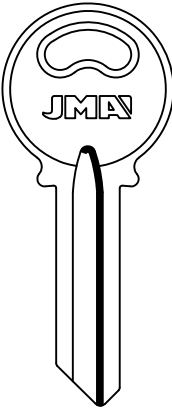
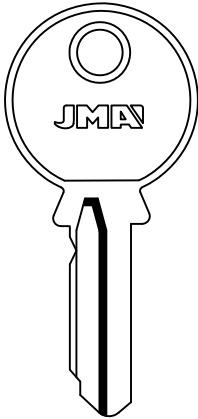
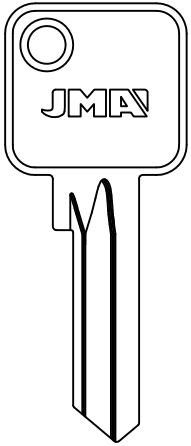

**REGAL**

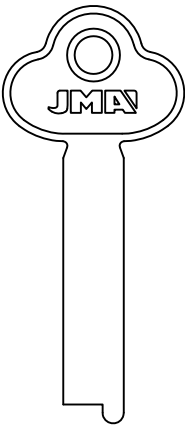
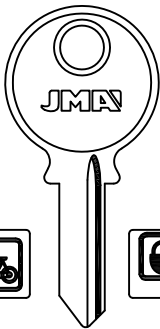
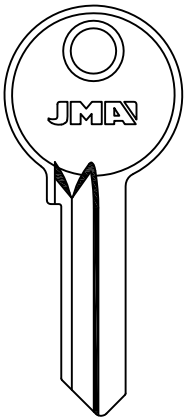
**RENZ**



**PARA-FOR:**

- RENZ (D)
- REX (DK)
- RGM (E)
- RIAZIAN (RUS)
- RICOUARD (F)
- RIGA (RUS)
- RIL (E)
- RIPA (E)
- RITA

| RENZ  |   | REX   | RGM   |   |
|---|---|---|---|---|
|    |    |   |    |   |
|    |    |    |    |  |
| RGM   | RIAZIAN   | RICOUARD  | RIGA  |   |
|   |   |    |   |   |
|  |    | <br>COUILLET-DECAYEUX-KIFERM<br>LAS-PASSY-YVEL   |  |   |
| RIL   | RIPA  | RITA  |   |   |
|  |    |    |   |   |
|  | <br><br> | <br><br> |  |   |
|   | ABUS-FADE   |   |   |   |





# RONIS

PARA-FOR:

RONIS (F)

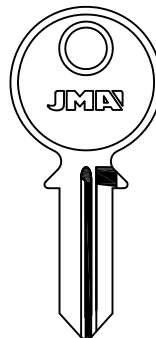
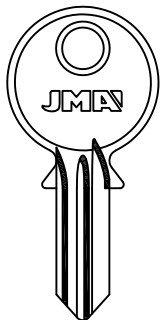

A8..AA-DS  
..8AB-ZZ  
S...385-402



A9..AA-DS  
..8AB-ZZ  
S...403-420



..4AB-ZZ  
S...331-348



RO-2I

..3AB-ZZ  
....1 AL 4



RO-2D

AA-JZ  
A4../A.4.



RO-4I

AA-JZ  
A3../A.3.  
S...213-246



RO-4D

AB-ZZ  
..6  
S...349-366



RO-6I

AB-ZZ  
..7  
S...367-384



RO-6D



C4..AA-ZY  
D4..AA-HR



RO-5I

C3..AA-ZY  
D3..AA-HR  
J...1-544



RO-5D

ABSA-FROSER-PJ-SADV

ABSA

# RONIS

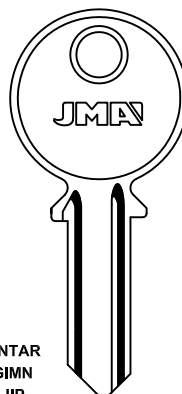
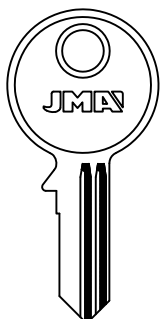

ARMOR  
EMHART  
FORINDEX  
KARDEX  
MLM  
NEMEF  
RONEO  
SANEL STRAFOR  
SCHAFFER  
YAC

...151-700  
E...1-1000  
T...107-400  
Y...101-600



...11 1-700  
A...A1-700  
C...101-600  
D...1-1000  
T...1-380  
TA...1-224  
GV...1-300  
...F1-500  
1F..1-21



RO-7D

...151-700  
E...1-1000  
T...107-400  
Y...101-600



RO-8I

T...1-380  
TA...1-224  
GV...1-300  
...F1-500  
1F..1-21



RO-8D

F...1-500



RO-30

...0 AL 8



RO-30D

RO-32D



RO-33



ANTAR  
GIMN  
JIP  
LAPERCHE  
PM  
SESA



RO-9I



RO-9D

# RONIS

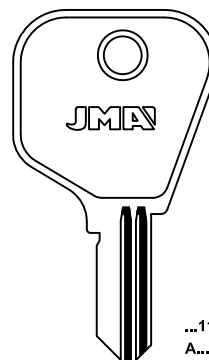
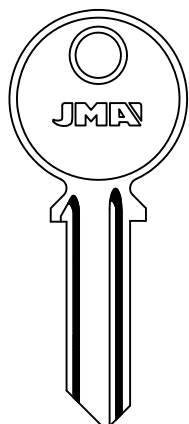

FM  
RO-18I  
LIONA LIOX-LAPERCHE



RO-19I



RO-19D

FK  
RO-20I  
FONTAINE-LAPERCHE



RO-21I



RO-20D



RO-22I



RO-21D



RO-23D

## RO-10D

ANTAR  
BLOCUS  
BAB  
DEBEAURAIN  
DELTA  
DERLOCHE  
DESPREZ  
DC  
EMGE  
EQUIBATIR  
FONTAINE  
FORINDEX  
GOLLOT  
GUIDOTTI  
JIP  
LAPERCHE  
LIONA-LIOX  
MAFOR  
MONDIAL  
MOREAUX  
NUMIDIA  
PM  
SESA  
STREMLER  
STUV  
VEGA

...11 1-700  
A...A1-700  
C...101-600  
D...1-1000  
T...1-380  
TA...1-224  
GV...1-300  
...F1-500  
1F..1-21

...151-700  
E...1-1000  
T...107-400  
Y...101-600



RO-11I



RO-11D

ABSA-SADV-SIMPLEX



**PARA-FOR:**

- RONIS (F)
- ROSSETTI (I)
- ROYAL (RC)
- RUKO (DK)

**RONIS**

**RO-12I**    **RO-12D**  
 M...601-983    TAV  
**RO-16I**    **RO-16D**  
**RO-24I**    **RO-24D**  
 ....1-1296  
 .....0 AL 9 AL 0  
 .....1 AL 9  
**RO-25I**    **RO-25D**  
 LAPERCHE  
**RO-26I**    **RO-26D**  
 LAPERCHE  
**RO-27I**    **RO-27D**  
 LAPERCHE  
**RO-28I**    **RO-28D**  
**RO-29D**    **RO-31D**  
**BURG-STRAFOR**    **ANTAR-LAPERCHE-SESA**    **SOLOR**

**RONIS**

**RO-34D**    **RO-36D**  
**CATOR**    **JD**  
**RO-37**    **RO-37D**    **RO-39**  
**RO-38**    **RO-38D**    **RO-40**    **RO-40D**  
**RO-41**    **RO-42**

**ROSSETTI**

**ROYAL**

**RUKO**

**ROSE-1**    **ROY-1**  
 LAT.    \* LAT.  
**RU-2I**    **RU-2D**  
**RU-3D**  
**RU-4D**  
**RU-10D**  
**RU-19D**  
**RU-TL**  
 ....1 AL 8  
 .....1 AL 9  
 .....1 AL 9 AL 0 A-B  
 .....0 AL 9 A AL M  
 S.....1 AL 9  
**RU-1D**  
**DIFA**



## RUKO

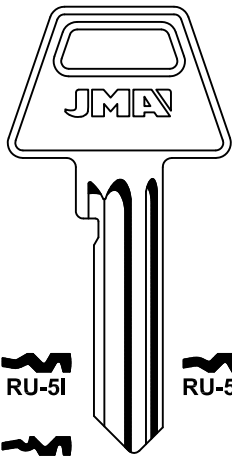

SKB  
RU-11D

RU-12D

RU-14D

RU-15

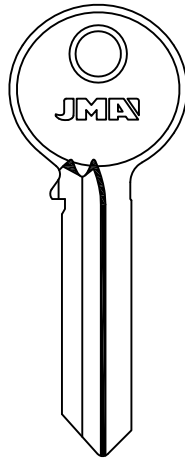

.....  
1 AL 9 A AL C  
RU-8D

GK  
RU-GK7

GL  
RU-GL7

GM  
RU-GM7

GS  
RU-GS7

RU-5I

RU-5D

RU-K

RU-KD

RU-6I

RU-L

RU-9I

RU-9D

RU-M

RU-7D

ASSA

## RUKO

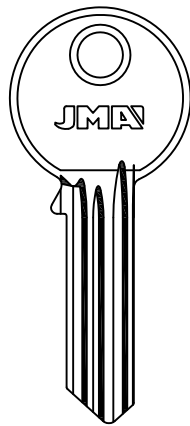
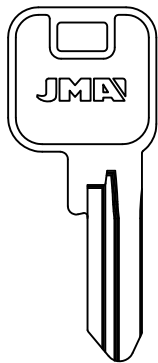

GK  
RU-GK  
GL  
RU-GL

GS  
RU-GS

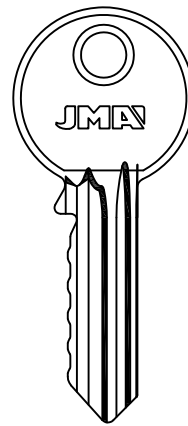

RU-13D

GC  
RU-GC

HNR  
RU-16D

GM  
RU-GM

ASSA

## RUSSIA

## RUSSWIN

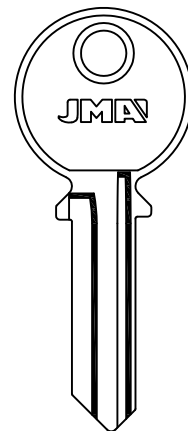
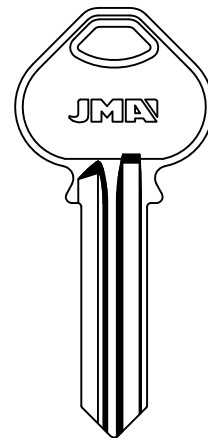
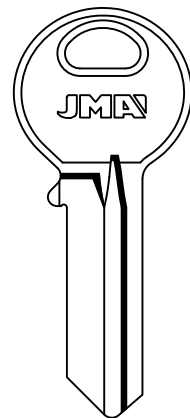
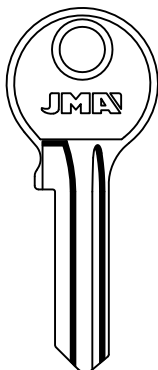

LAT.

RSS-1

RSS-2D

RUS-1







RUS-2



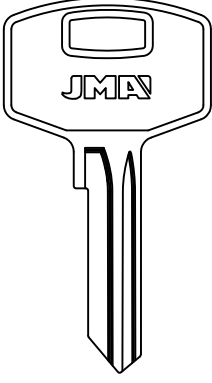
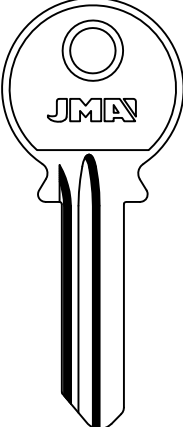
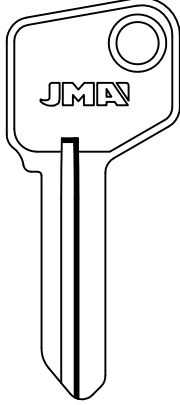
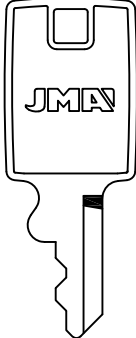





PARA-FOR:  
RUKO (DK)  
RUSSIA (RUS)  
RUSSWIN (USA)

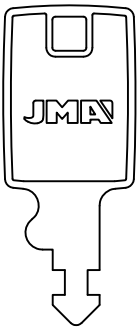
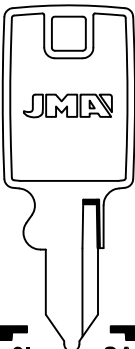
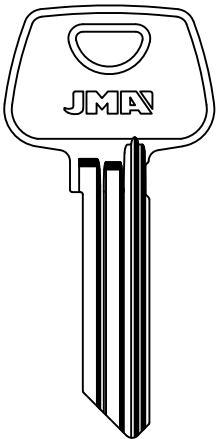
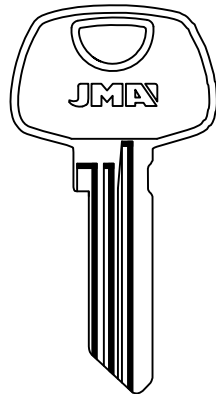







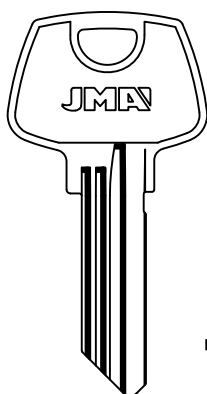
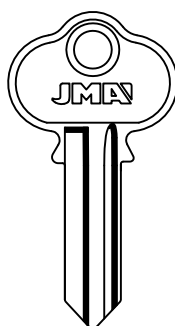
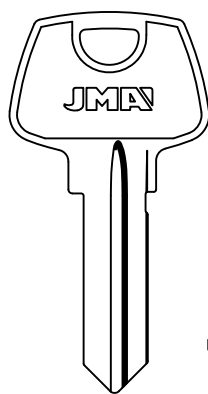
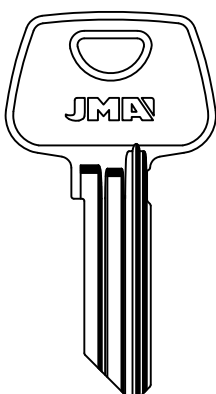

**PARA-FOR:**

- SABT (KW)
- SAM (RUS)
- SAMSONITE (USA)
- SARGENT (USA)

| SABT  | SAM   |   | SAMSONITE   |
|---|---|---|---|
|            |            |             |    |
| <br>SABT-1 | <br>SAM-1D | <br>SAM-2D | 170 S<br><br>SA-1 <br>SA-1D |

| SAMSONITE   |  | SARGENT   |   |
|---|--|---|---|
|           |    |    |                                   |
| <br>SA-2 | <br>SA-3I <br>SA-3D<br>SE 041<br>SE 052<br>SE 083<br>SE 124<br>SE 165<br>SE 186<br><br>SA-4 | LN      RN<br><br>SAR-1 <br>SAR-1D | S<br><br>SAR-2D<br>BRICARD-SHOWA |

| SARGENT   |  |   |  |   |   |
|---|--|---|--|---|---|
|                    |   |                     |   |  |  |
| LAT.<br><br>SAR-3D | LAT.<br><br>SAR-4 <br>SAR-4D | LAT.<br><br>SAR-5D | LAT.<br><br>SAR-6 <br>SAR-6D | LN      RN<br>1 AL 9  |   |



**SATURN**

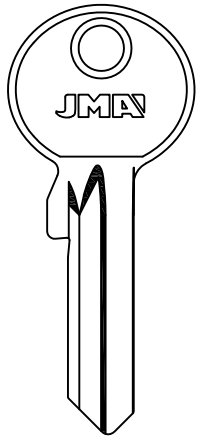

SAT-1D

GERA-VERA

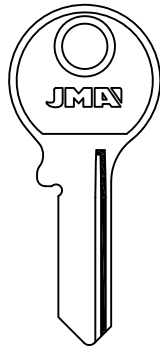

SAT-2

**SCHÄRER**

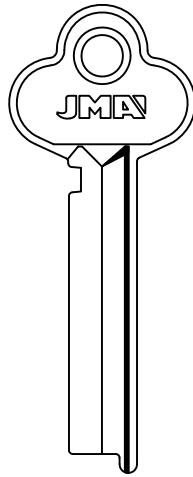

SHR-1

LAT.

**SCHLAGE**

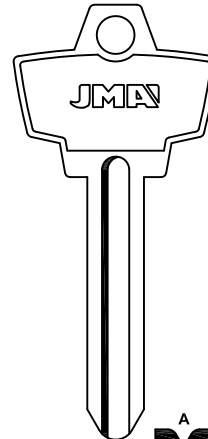

A  
SLG-1

W  
SLG-2

EPO

**PARA-FOR:**

- SATURN (D)
- SCHÄRER (USA)
- SCHLAGE (USA)
- SCHLECHTENDAHL (D)
- SCHUCO (D)
- SEA (CH)

**SCHLAGE**

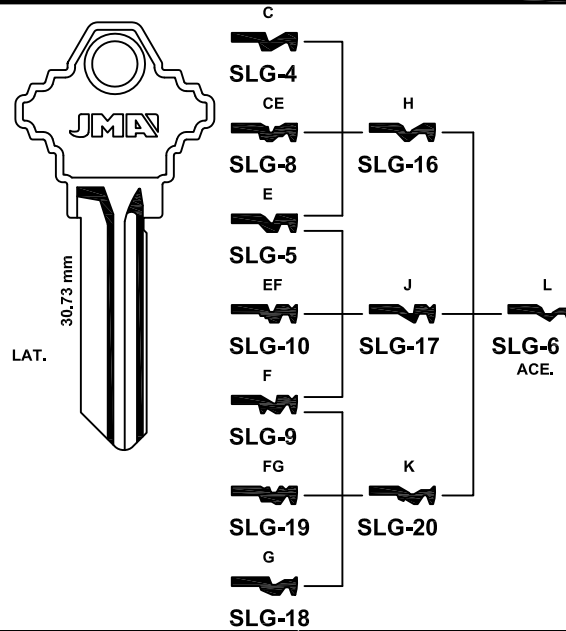
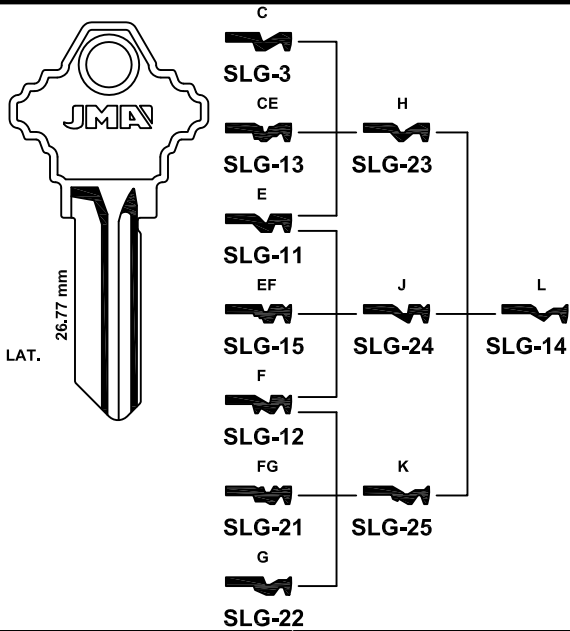

**SCHLAGE**

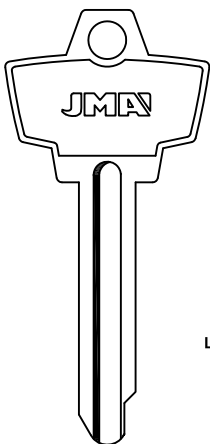

A  
SLG-7

LAT.

**SCHLECHTENDAHL**

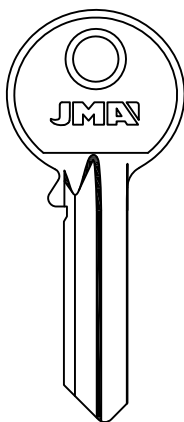

SCH-1D

CASI-HUTRA-NORDWEST

**SCHUCO**

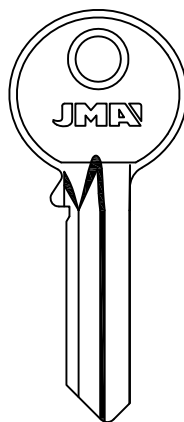

SCC-1D

**SEA**

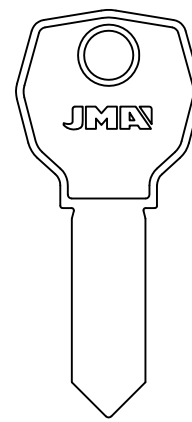

9.5  
20-23  
2.2  
SEA-1

EZCURRA-HASLER-VIDMAR



**PARA-FOR:**

- SEA (CH)
- SECUREMME (I)
- SECURITAL (I)
- SELECT (F)
- SELIVANOVSK (RUS)
- SENTRY SAFE (USA)
- SERRALLER (E)
- SERRETA (E)

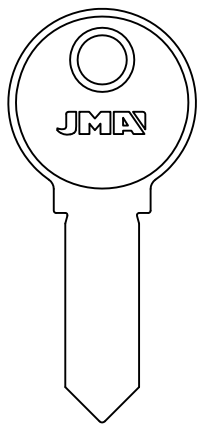
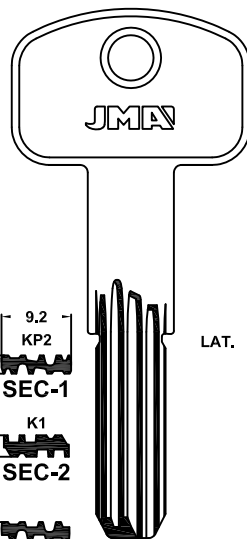
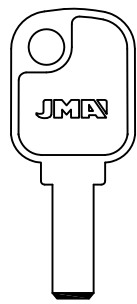
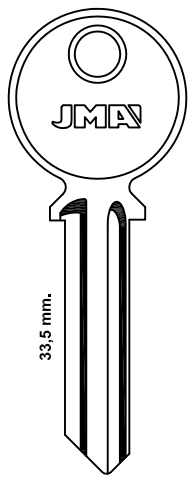
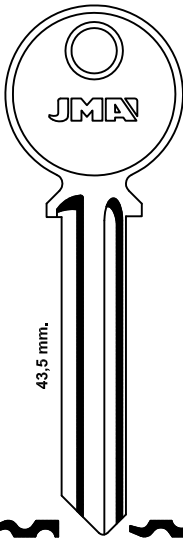
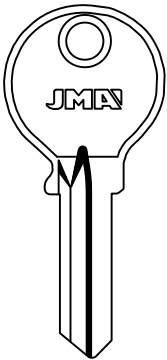
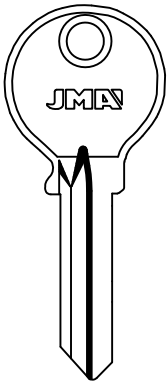
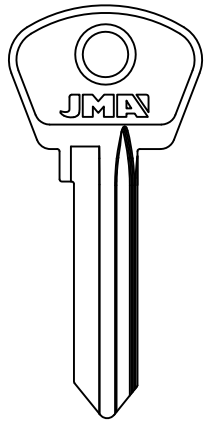
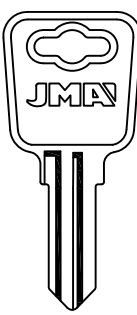
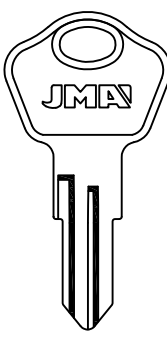
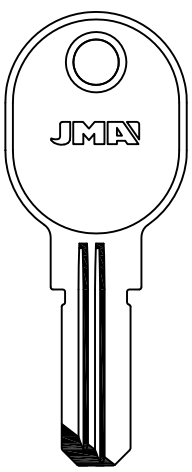
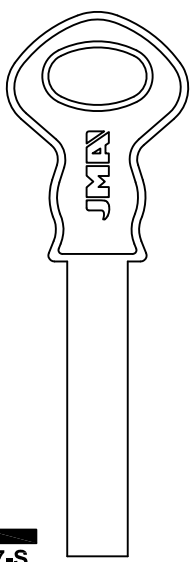
| SEA   | SECUREMME  | SECURITAL   | SELECT   |
|---|--|---|--|
|  <p style="text-align: center;">JMA</p> <p style="text-align: center;">LAT.</p> <p style="text-align: center;">.....1 AL 7</p> <p style="text-align: center;">9.5</p> <p style="text-align: center;">2.2</p> <p style="text-align: center;">SEA-2</p> <p style="text-align: center;">EZCURRA-HASLER-VIDMAR</p> |  <p style="text-align: center;">JMA</p> <p style="text-align: center;">LAT.</p> <p style="text-align: center;">9.2</p> <p style="text-align: center;">KP2</p> <p style="text-align: center;">2.4</p> <p style="text-align: center;">SEC-1</p> <p style="text-align: center;">K1</p> <p style="text-align: center;">2.85</p> <p style="text-align: center;">SEC-2</p> <p style="text-align: center;">2.37</p> <p style="text-align: center;">SEC-3</p> |  <p style="text-align: center;">JMA</p> <p style="text-align: center;">LAT.</p> <p style="text-align: center;">ZAM.</p> <p style="text-align: center;">5.46</p> <p style="text-align: center;">1.9</p> <p style="text-align: center;">SCR-1</p> <p style="text-align: center;">KYR</p> |  <p style="text-align: center;">JMA</p> <p style="text-align: center;">LAT.</p> <p style="text-align: center;">33.5 mm.</p> <p style="text-align: center;">SEL-1I</p> <p style="text-align: center;">SEL-1D</p> |
| SELECT  |  |   | SELIVANOVSK  |
|  <p style="text-align: center;">JMA</p> <p style="text-align: center;">LAT.</p> <p style="text-align: center;">43.5 mm.</p> <p style="text-align: center;">SEL-2I</p> <p style="text-align: center;">SEL-2D</p>   |  <p style="text-align: center;">JMA</p> <p style="text-align: center;">LAT.</p> <p style="text-align: center;">SEL-3D</p>  |  <p style="text-align: center;">JMA</p> <p style="text-align: center;">LAT.</p> <p style="text-align: center;">SEL-4D</p>   |  <p style="text-align: center;">JMA</p> <p style="text-align: center;">LAT.</p> <p style="text-align: center;">SL-1</p>  |
| SENTRY SAFE   |  | SERRALLER   | SERRETA  |
|  <p style="text-align: center;">JMA</p> <p style="text-align: center;">LAT.</p> <p style="text-align: center;">SEN-1D</p>  |  <p style="text-align: center;">JMA</p> <p style="text-align: center;">LAT.</p> <p style="text-align: center;">SEN-2D</p>   |  <p style="text-align: center;">JMA</p> <p style="text-align: center;">LAT.</p> <p style="text-align: center;">SER-3D</p>   |  <p style="text-align: center;">JMA</p> <p style="text-align: center;">LAT.</p> <p style="text-align: center;">7-S</p>  |

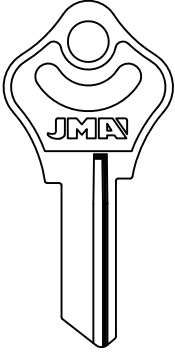
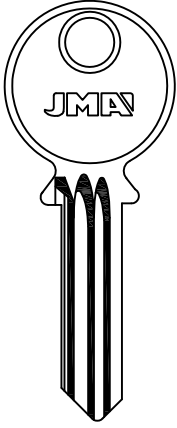
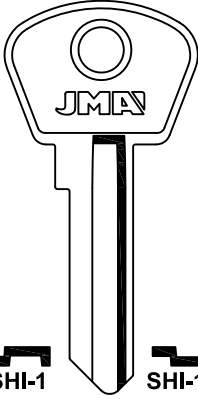
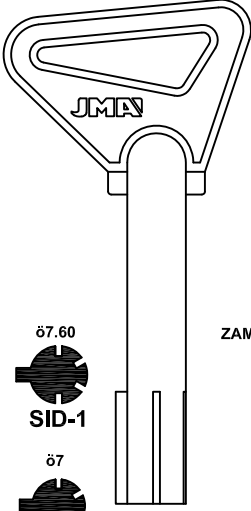

| SHANGAI  | SHAW  | SHILUTE   | SIDESE  |
|--|---|---|---|
|  <p>SHA-1</p> <p>CINA</p> |  <p>SH-11</p> <p>HTV-VAUGHN-YALE</p> |  <p>SHI-1 SHI-1D<br/>SHI-2D<br/>SHI-3D</p> |  <p>SID-1 SID-2</p> <p>ZAM.</p> |

**PARA-FOR:**  
 SHANGAI (RC)  
 SHAW (GB)  
 SHILUTE (RUS)  
 SIDESE (E)  
 SIMECA (CH)  
 SIS (I)

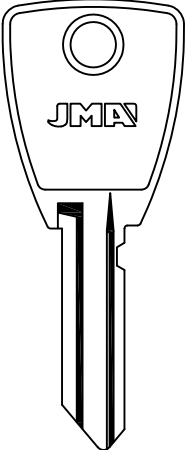
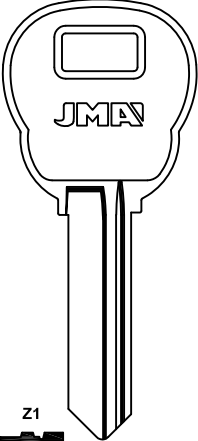
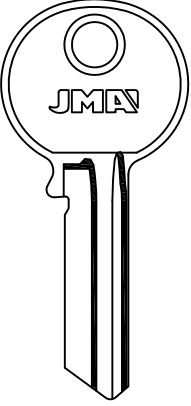
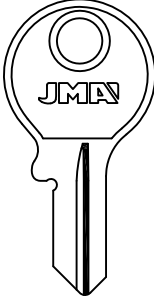
| SIMECA  |  |  | SIS  |
|---|--|--|--|
|  <p>SM-1</p> <p>GUTLER-KATE-ORBA<br/>SIAM-SIMATIC</p> |  <p>SM-2 SM-3 SM-3D</p> <p>GUTLER-KATE-ORBA<br/>SIAM-SIMATIC</p> |  <p>SM-4 SM-4D</p> |  <p>SIS-1</p> <p>FEL</p> |

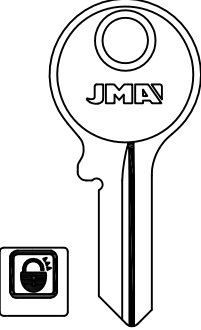
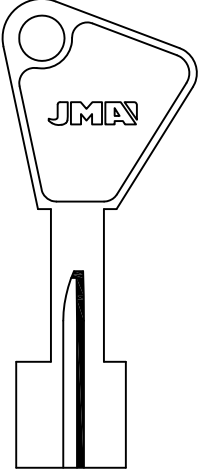
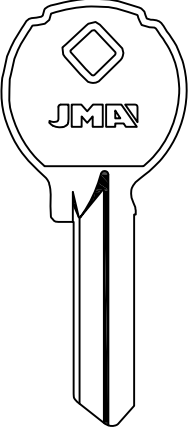
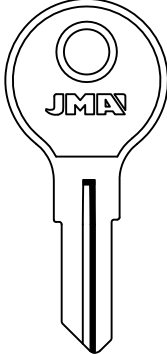
| SIS   |  |   |   |
|---|--|---|---|
|  <p>SIS-2</p> <p>SIS-6 SIS-6D</p> <p>SIS-7D</p> <p>UTZ-ZENITH</p> |  <p>SIS-3</p> |  <p>SIS-4D</p> <p>LAT.</p> <p>LÅSBOLAGET</p> |  <p>SIS-5D</p> |



**PARA-FOR:**

- SIS (I)
- SISO (I)
- SJL (RUS)
- SOFER (P)
- SOFI-SONAFI (P)
- SOLER (E)
- SOPRANO (BR)

|             |         | SIS         |  | SISO          |  | SJL |  |
|-------------|---------|-------------|--|---------------|--|-----|--|
|             |         |             |  |               |  |     |  |
|             |         |             |  |               |  |     |  |
|             |         |             |  |               |  |     |  |
|             |         |             |  | EVERGOOD-JOMA |  |     |  |
| SOFER       |         | SOFI-SONAFI |  |               |  |     |  |
|             |         |             |  |               |  |     |  |
|             | 26.4 mm |             |  |               |  |     |  |
|             | 29.1 mm |             |  |               |  |     |  |
| SIL         |         |             |  |               |  |     |  |
| SOFI-SONAFI |         | SOLER       |  | SOPRANO       |  |     |  |
|             |         |             |  |               |  |     |  |
|             |         |             |  |               |  |     |  |
|             |         |             |  |               |  |     |  |
|             |         | 90 mm       |  |               |  |     |  |





**SOS**

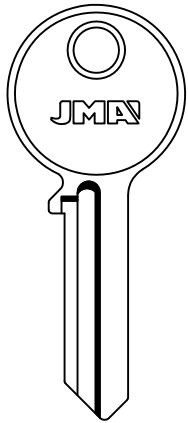

 SOS-1D

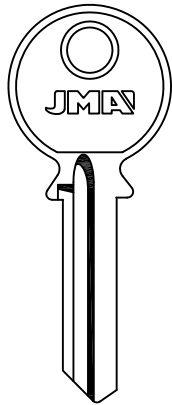

 SOS-2D

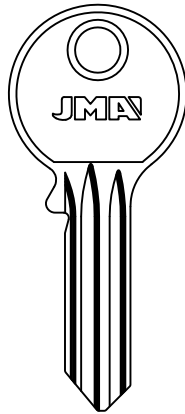

 SOS-3

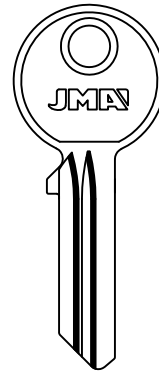

 SOS-4D

**PARA-FOR:**

- SOS (F)
- SPIDER (IL)
- SQUIRE & SONS (GB)

**SOS**

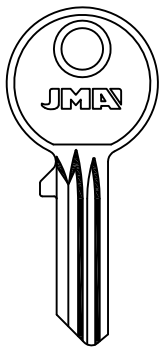

 SOS-5

**SPIDER**

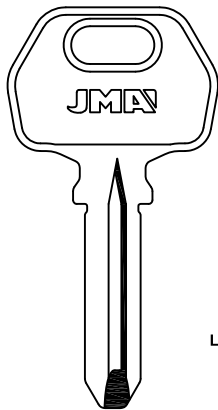

LAT.



CAVERS-CODKEY-LOCKSYS

**SQUIRE & SONS**

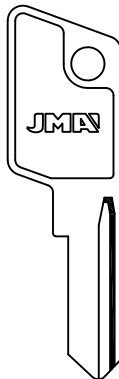

 SQ-1

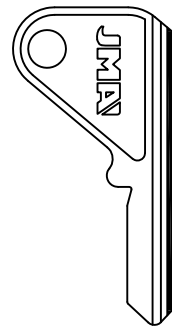

 SQ-2

**SQUIRE & SONS**

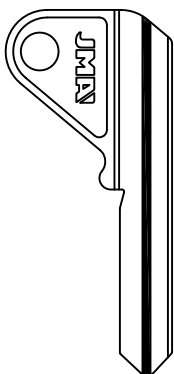

 SQ-3D

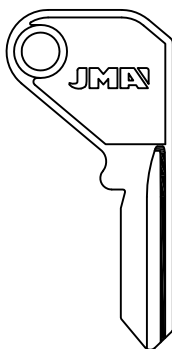

 SQ-4

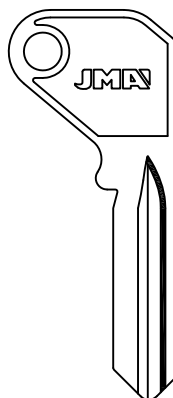

 SQ-5D

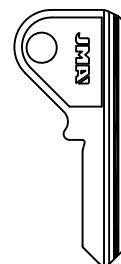

 SQ-6



**PARA-FOR:**

SQUIRE & SONS  
(GB)

STA-LOCK (GB)

STAR (J)

STARLET (D)

STEKLOMASH  
(RUS)

**SQUIRE & SONS**

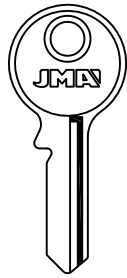

**SQ-7**

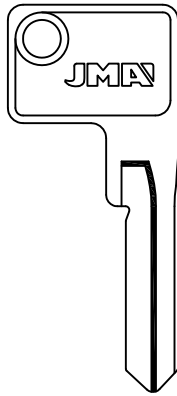

**SQ-8D**

**STA-LOCK**

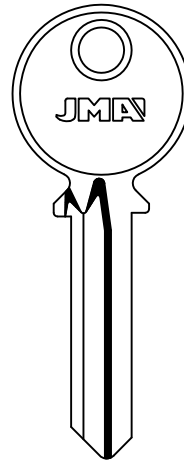

**STL-1D**

SECURE

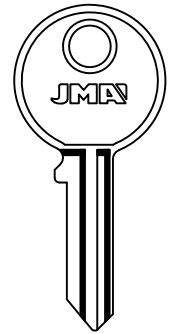

**STL-2I**

SECURE

**STAR**

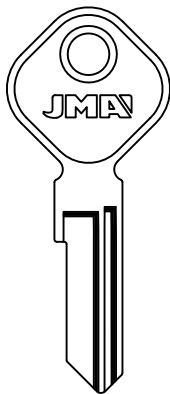

**STA-1**

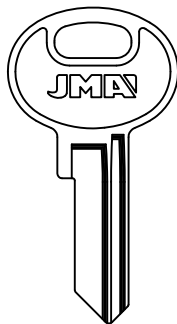

**STA-1D**

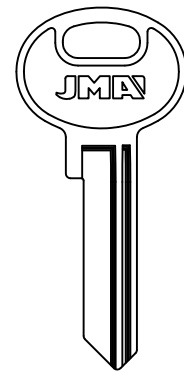

**STA-2**

**STA-2D**

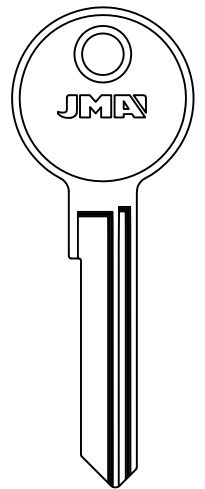

**STA-3**

**STA-3D**

K...  
1-1600

**STA-4**

**STA-4D**

**STAR**

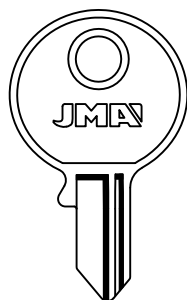

**STA-5**

**STA-5D**

**STARLET**

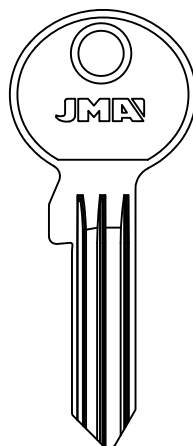

**ST-1I**

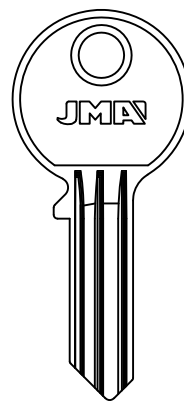

**ST-2**

**STEKLOMASH**

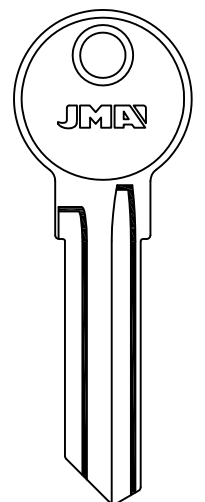

**STK-1**



| STEM |       |        | STERLING | STREBOR |         |       |  |
|------|-------|--------|----------|---------|---------|-------|--|
|      |       | STE-8D |          |         |         |       |  |
|      |       | STE-7  |          |         | STE-14D |       |  |
|      |       | STE-6  |          |         | STE-13D |       |  |
|      |       | STE-5D |          |         | STE-12  |       |  |
|      |       | STE-4  |          |         | STE-11  |       |  |
|      |       | STE-3  |          |         | STE-10  |       |  |
|      |       | STE-2D |          |         | STE-9D  |       |  |
|      |       | STE-1  |          |         |         |       |  |
|      | GE GE |        |          |         | STG-1   | STR-1 |  |

**PARA-FOR:**  
 STEM (D)  
 STERLING (GB)  
 STREBOR (GB)  
 STS (E)

| STREBOR            |         |       | STS          |          |
|--------------------|---------|-------|--------------|----------|
|                    |         |       |              |          |
| TS...300-369       | S..1-70 |       | ALU.<br>LAT. |          |
|                    |         |       |              |          |
| STR-2<br>INNOCENTI | STR-4   | STR-5 | STS-28       | STS-1D.P |

| STS    |        |        |          |        |
|--------|--------|--------|----------|--------|
|        |        |        |          |        |
|        |        |        |          |        |
| STS-3I | STS-3D | STS-4D | STS-4D.P | STS-6D |
| SEMEL  | BTV    | BTV    | BTV      | BTV    |



**PARA-FOR:**

STS (E)

STUBLINA (SCG)

STUMPF (D)

STUV (D)

**STS**

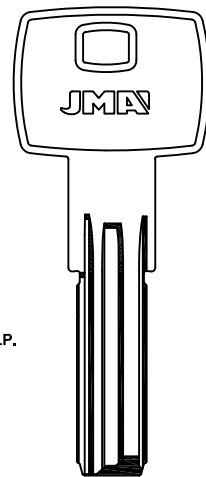
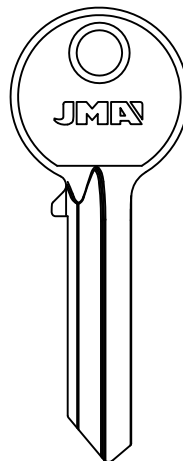
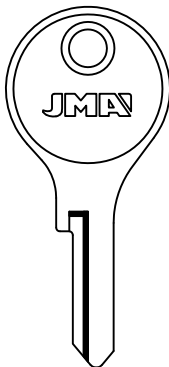
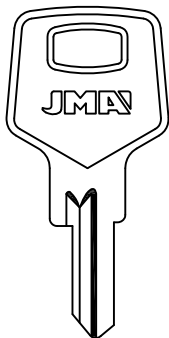

STS-7D

BTV

STS-12D

DAD

STS-13D

STS-21D

STS-35

MEGA6  
STS-38

ALP.

LAT.

**STS**

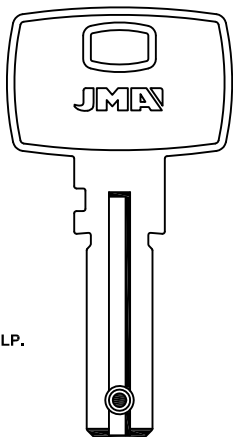

ALP.

IX-BOLA  
STS-B1

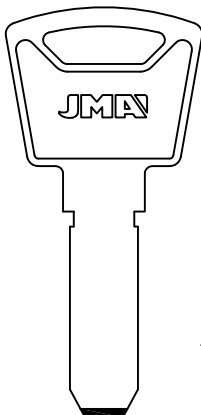

STS-T14

CAYS

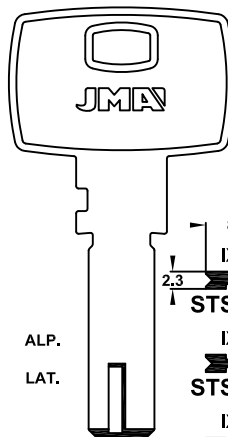

ALP.

ALP.

LAT.

DOM-ESAFE  
FAC-IFAM  
SERRALLER  
TECSESA  
TECNOLAR

IX-3  
STS-TV3  
IX-5  
STS-TV5  
IX-8  
STS-TV8  
IX-9  
STS-TV9

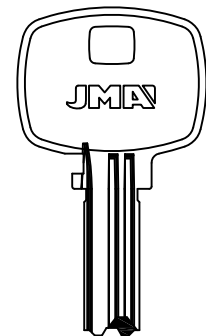

LAT.

STS-X5

**STS**

**STUBLINA**

**STUMPF**

**STUV**

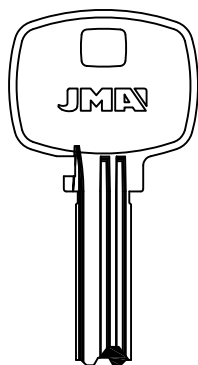

LAT.



STS-X6

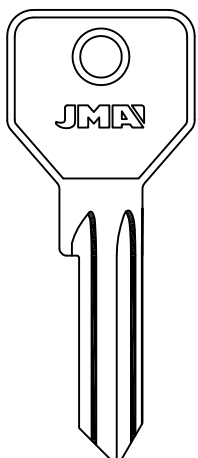

STB-1

STB-1D

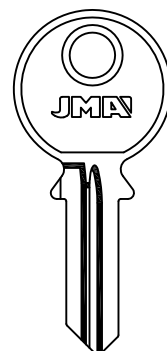

STF-1

STF-1D

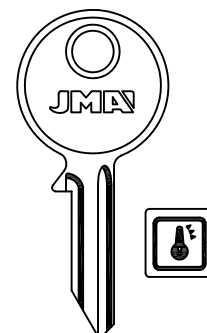

1F...201-278  
1F...Z201-278  
1F...X201-278

STUV-1I

STUV-1D

9F  
STUV-3

DOM-MLM

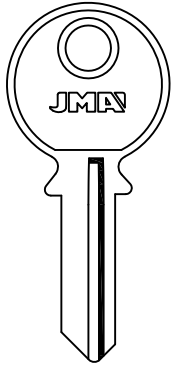

**STUV**

STUV-2

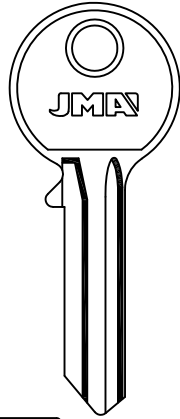
**SUREX**

SR-1I

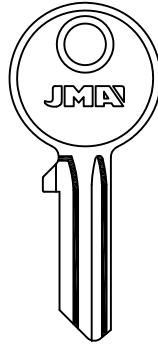

SR-2

ATLAS

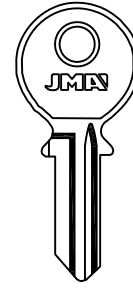

SR-3

ATLAS-EUROP-MATTEY

**PARA-FOR:**

STUV (D)

SUREX (F)

T-KEY

TAITO (J)

TALLINN (RUS)

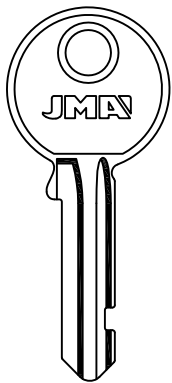
**SUREX**

SR-4

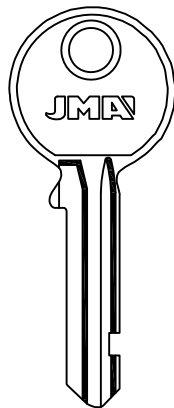

SR-5

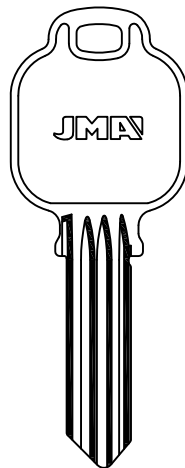
**T-KEY**

TKY-1

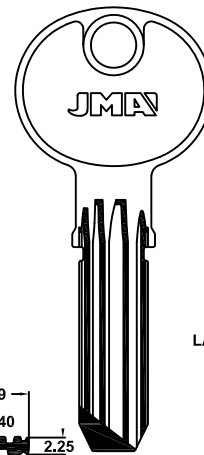

LAT.

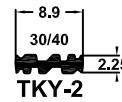

TKY-3

BAILING LOCK

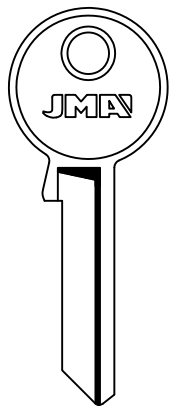
**TAITO**

TAI-1

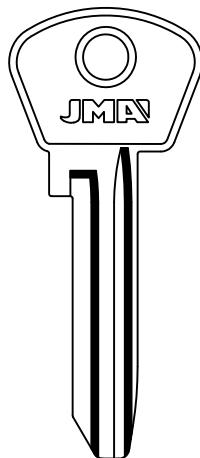
**TALLINN**

TAL-1

TAL-1D

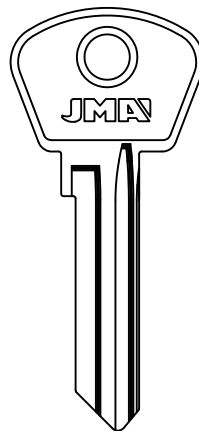

TAL-2

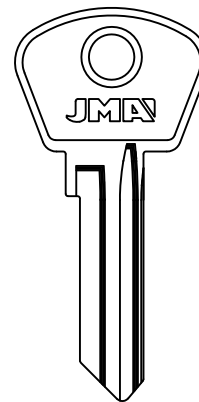

TAL-3



**PARA-FOR:**

- TARONI (I)
- TAYLOR (USA)
- TECON (E)
- TECSESA (E)
- TEICOCIL (P)
- TEKA (S)
- TEM (E)
- TESA (E)

|  | TARONI                              | TAYLOR                           | TECON  |                         |
|--|-------------------------------------|----------------------------------|--|-------------------------|
|  | <p>LAT.</p> <p>TRO-1 TRO-1D</p>     | <p>TAY-1</p>                     | <p>LAT.</p> <p>TC-1 TC-2</p>                               | <p>TC-2</p>             |
|  | TECSESA                             | TEICOCIL                         | TEKA   | TEM                     |
|  | <p>ALP.</p> <p>TEC-2</p>            | <p>TEI-1D</p>                    | <p>20104 20004</p> <p>TK-2I TK-2D</p> <p>ASSA-ERMEX-LM</p> | <p>TEM-I35 TEM-D35</p>  |
|  | TEM                                 | TESA                             |  |                         |
|  | <p>TEM-I55 TEM-D55</p> <p>CORSA</p> | <p>* LAT.</p> <p>TE-1I TE-1D</p> | <p>TE-3</p> <p>MR</p>                                      | <p>TE-4</p> <p>IFOS</p> |



## TESA

PARA-FOR:

TESA (E)

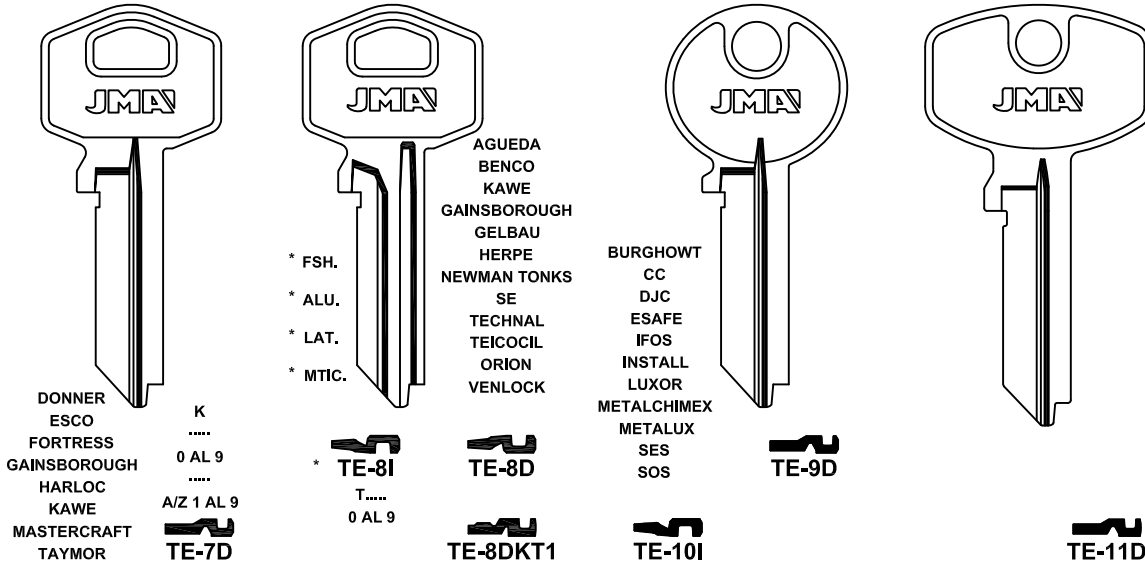

## TESA

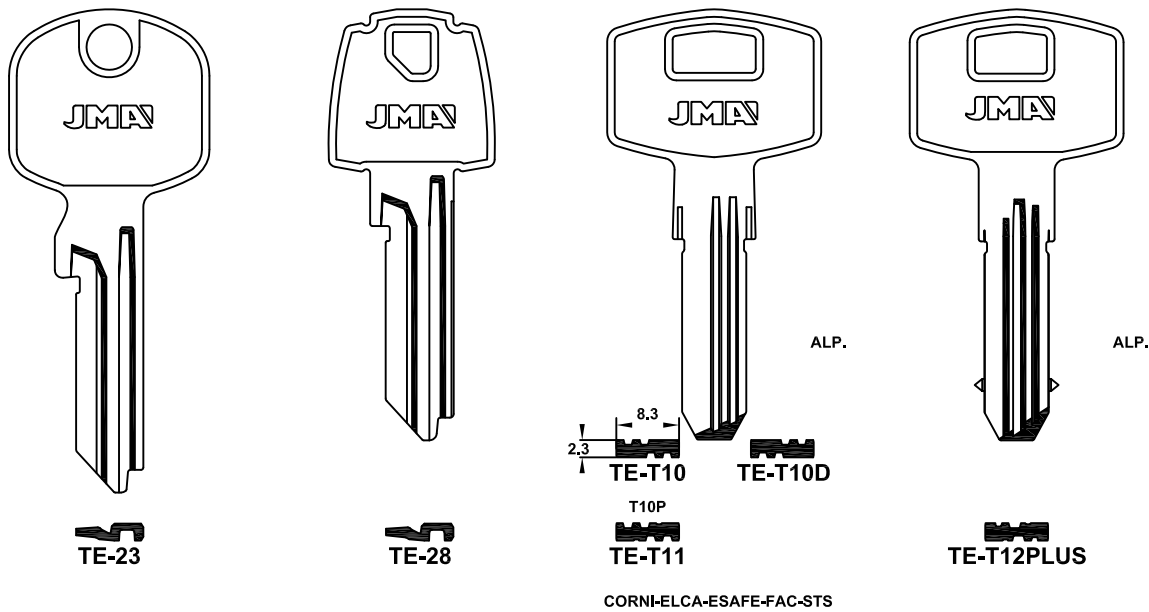



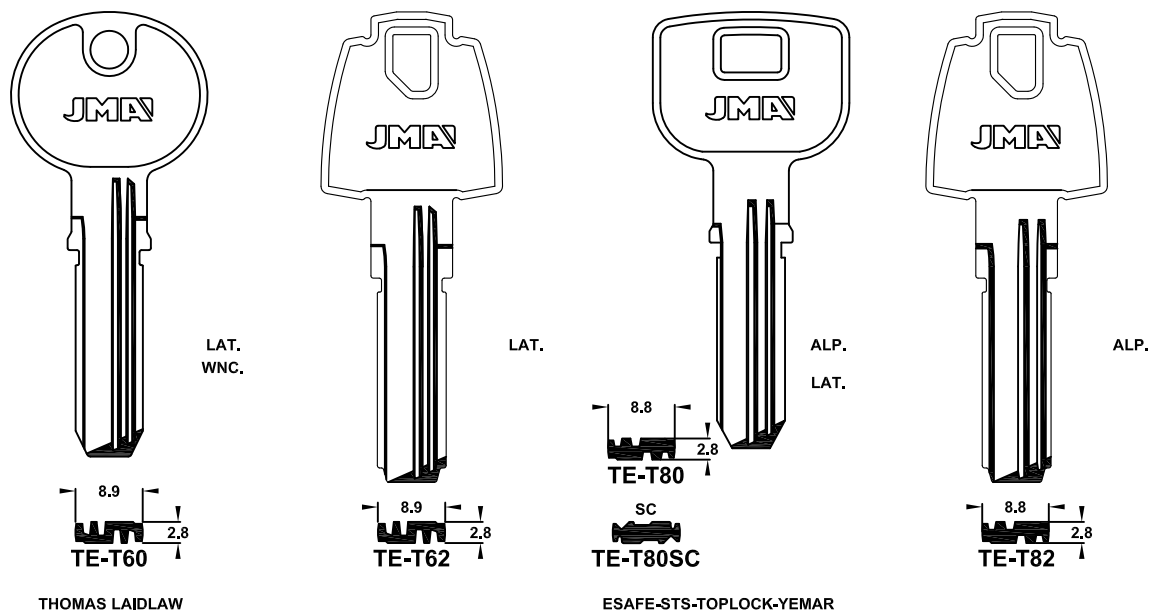





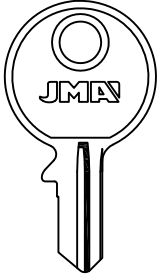
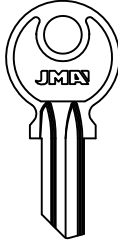
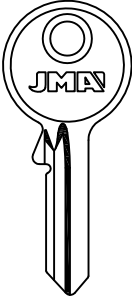
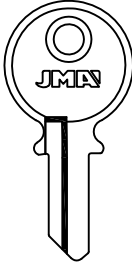





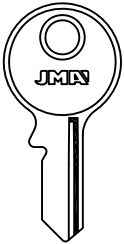
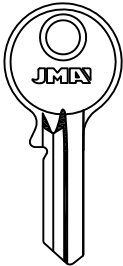
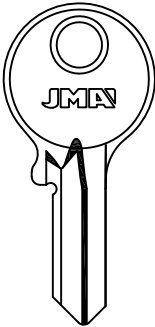
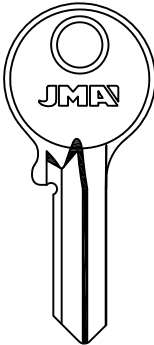





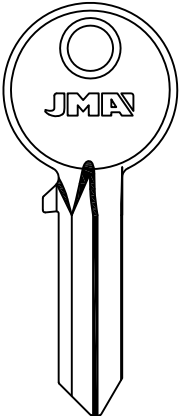
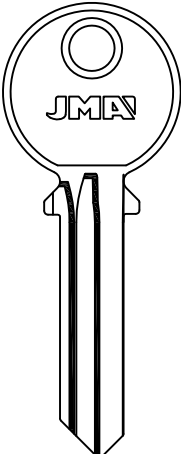
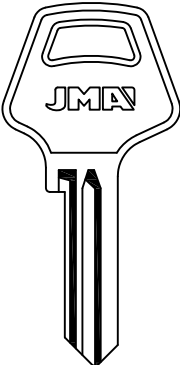
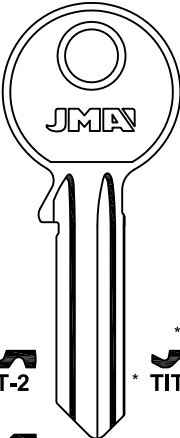

## TESA



**PARA-FOR:**

- TH (D)
- TICINO (I)
- TIFON (RC)
- TIGRIS (GB)
- TITAN (SLO)

|  | TH  | TICINO  | TIFON   |   |
|--|---|---|---|---|
|  |                    |    |    |                        |
|  | <br>TH-1<br>TRUMPH |  <br>TI-1 TI-1D<br>BERTOLOTTI | <br>TIF-1D   | <br>TIF-2D             |
|  |   |   | <br>25   |   |
| TIFON  |   |   |   |   |
|  |                   |   |   |                       |
|  | <br>TIF-15/20    | <br>TIF-25D  | <br>TIF-30D  | <br>TIF-40D          |
|  | <br>15-20        | <br>25   | <br>30   | <br>40               |
| TIFON  | TIGRIS  | TITAN   |   |   |
|               |                  |   |    |   |
| <br>TIF-50/60 | <br>TIG-1D       | <br>TIT-1D<br>HILLMANN-PAYKAN  | <br>TIT-2<br><br>TIT-10 | <br>TIT-2D<br>* ALU. |
| <br>50-60     |   |   |   |   |





## TITAN

PARA-FOR:

TITAN (SLO)

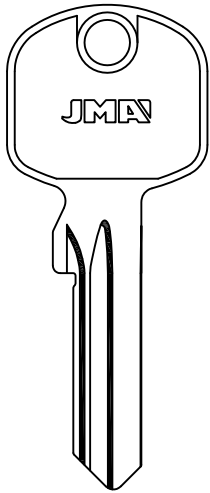

TIT-2GD

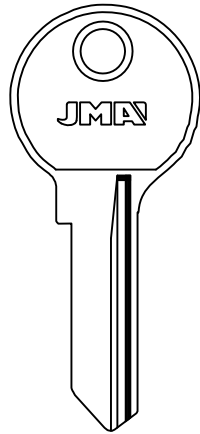

TIT-3

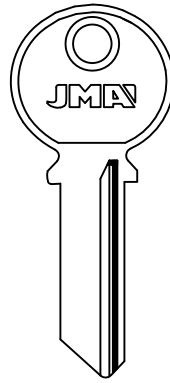

TIT-4

FTH-VACHETTE

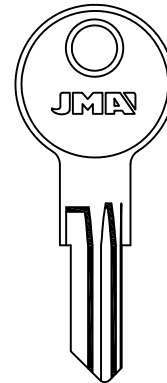

TIT-5

## TITAN

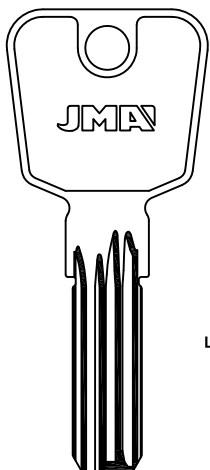

LAT.

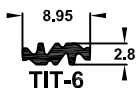

TIT-6

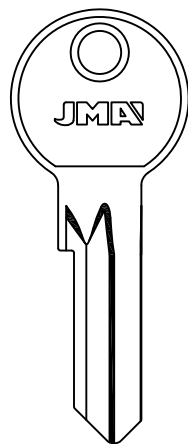

ALU.

TIT-8D

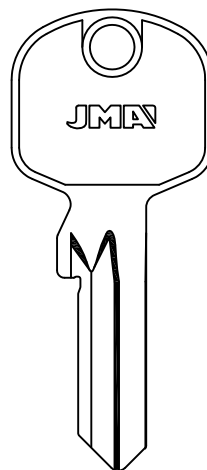

TIT-8GD

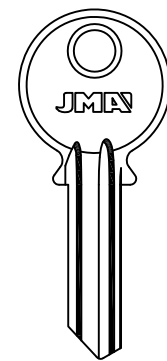

TIT-9

TIT-9D

LAMA

## TITAN

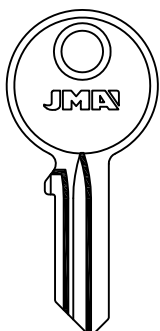

...251-300

TIT-11D



TIT-12D

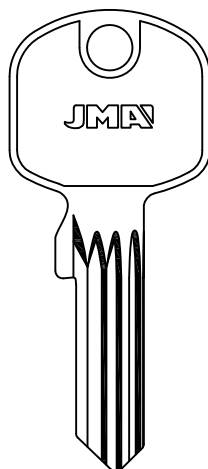

TIT-13

PICARDIE

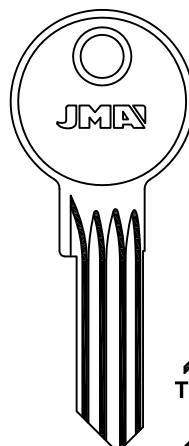

TIT-15

PICARDIE

TIT-18D

TIT-16D

TIT-15D

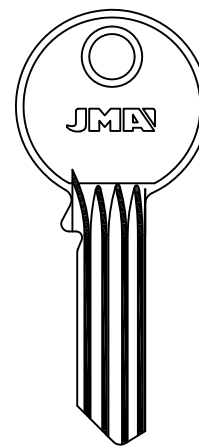





TIT-17



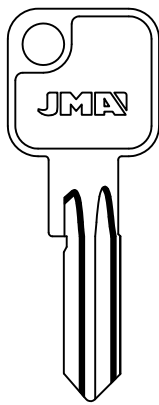

**PARA-FOR:**  
TOK WINKHAUS  
(D)

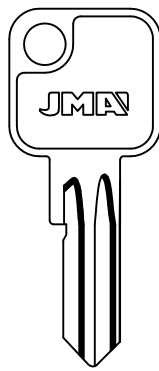
### TOK WINKHAUS

  
  
**TOK-2**  
TRELOCK

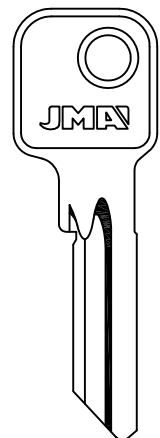
  
  
**TOK-3**  
TRELOCK

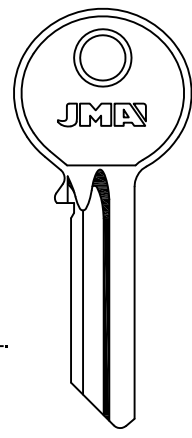
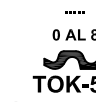

  
  
**TOK-4**  
TRELOCK



  
  
**TOK-5**  
COMBA-SIEBAU  
TRELOCK-VACHETTE

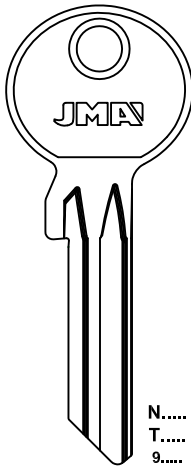

COL.

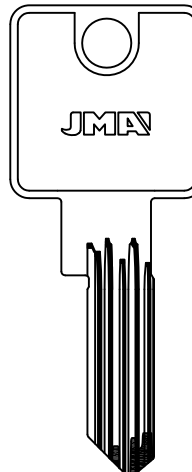

N/T/9.....  
.....  
0 AL 8



### TOK WINKHAUS



  
  
**TOK-6**   **TOK-6D**

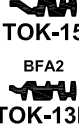

  
  
**TOK-7**   **TOK-7D**



  
  
**TOK-11**



  
  
**TOK-12**



  
  
**TOK-13**



  
  
**TOK-14**



  
  
**TOK-15**



  
  
**TOK-16**



  
  
**TOK-17**



  
  
**TOK-18**



  
  
**TOK-23**



  
  
**TOK-27**

  
  
**TOK-28**

  
  
**TOK-29**



  
  
**TOK-32**



  
  
**TOK-33**

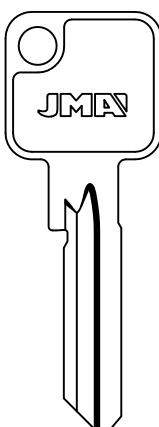

  
  
**TOK-34**

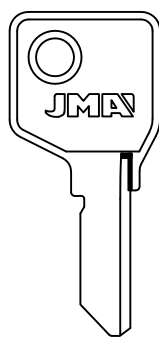

FICHET-BIFFAR

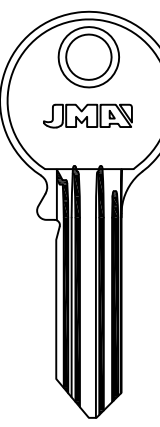

### TOK WINKHAUS

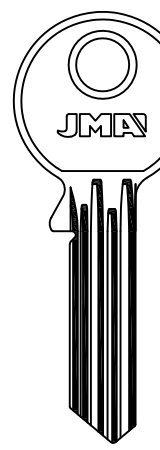

  
  
**TOK-17**  
TRELOCK

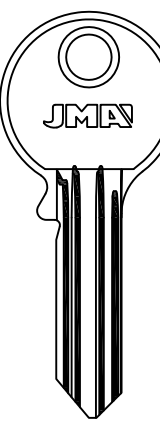

  
  
**TOK-18**

  
  
**TOK-19**

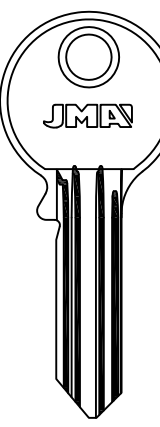
  
  
**TOK-20**

  
  
**TOK-29**

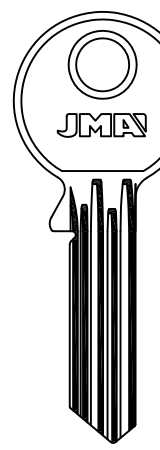
  
  
**TOK-30**

  
  
**TOK-31**

## TOK WINKHAUS

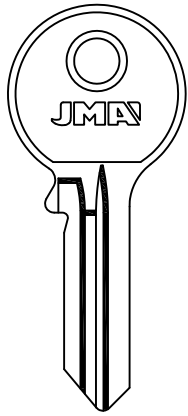

W  
TOK-56D

TRELOCK

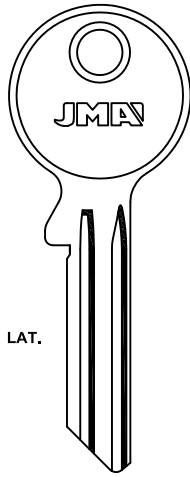

LAT.

LAT.



TOK-75



TOK-61



TOK-60



TOK-59



TOK-58



TOK-78



TOK-77

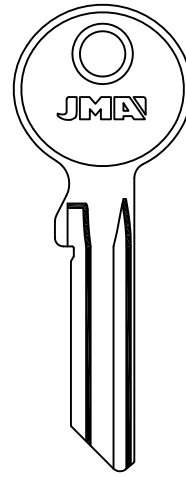

LAT.

TOK-76

SERIE AZ 01 N

PARA-FOR:  
TOK WINKHAUS  
(D)

## TOK WINKHAUS

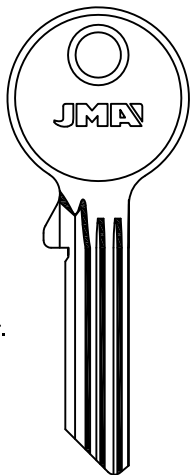

LAT.



X7  
TOK-37



X6  
TOK-62



X5  
TOK-47



X4  
TOK-21



X3  
TOK-46



X2  
TOK-45



X1  
TOK-44



X6  
TOK-62D



X5  
TOK-47D



X4  
TOK-21D

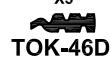

X3  
TOK-46D



X2  
TOK-45D



X1  
TOK-44D



X14  
TOK-40



X13  
TOK-8



X12  
TOK-39



X11  
TOK-38



X10  
TOK-48



X9  
TOK-67



X8  
TOK-63

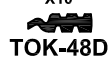

X10  
TOK-48D



X18  
TOK-69



X17  
TOK-68



X16  
TOK-41



X15  
TOK-49



X16  
TOK-41D

SERIE X

## TOK WINKHAUS

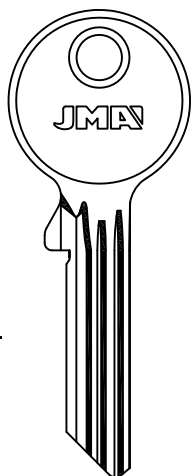

LAT.



Y7  
TOK-52



Y6  
TOK-43



Y5  
TOK-51



Y4  
TOK-70



Y3  
TOK-22



Y2  
TOK-42



Y1  
TOK-50



Y14  
TOK-24



Y13  
TOK-72



Y12  
TOK-66



Y11  
TOK-64



Y10  
TOK-54



Y9  
TOK-53



Y8  
TOK-71



Y8  
TOK-71D



Y18  
TOK-74



Y17  
TOK-65



Y16  
TOK-55



Y15  
TOK-73

SERIE Y



**PARA-FOR:**





TOMSK (RUS)



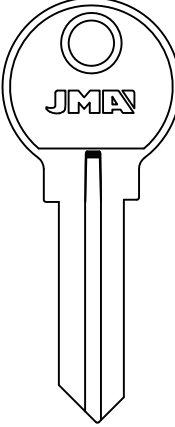
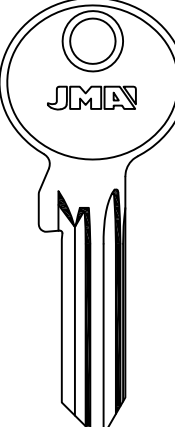
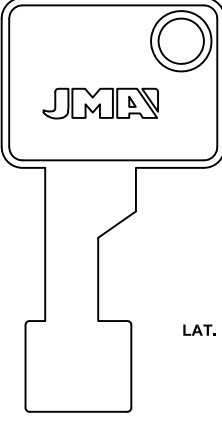
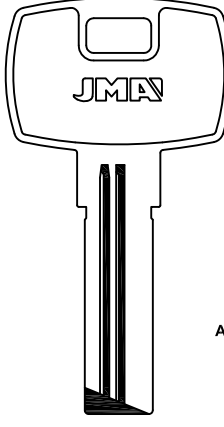

TOP (D)



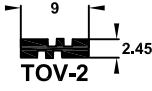

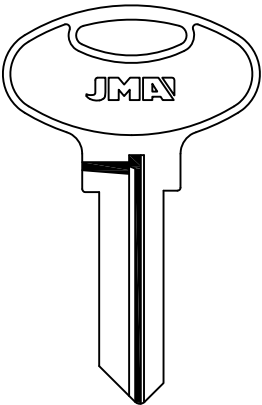
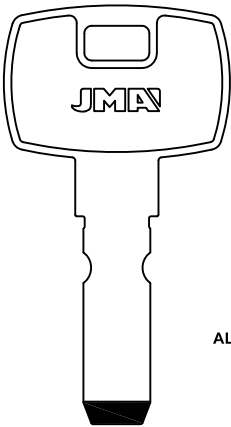
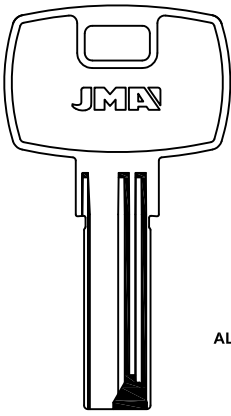
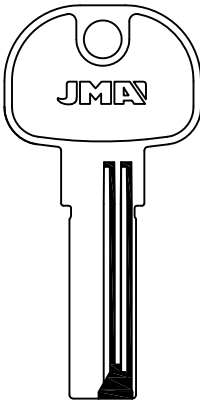
TOVER (E)

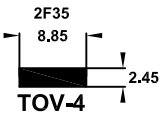
TRAVEX (PE)

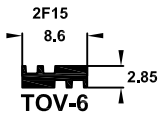
TRELOCK (D)

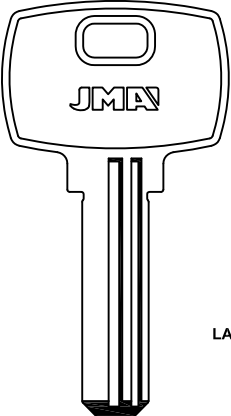
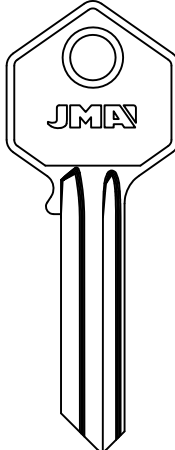
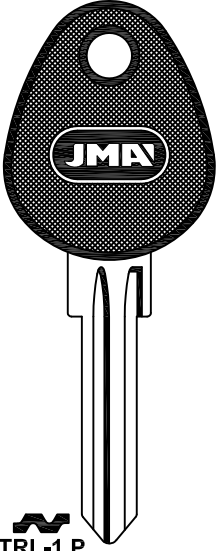
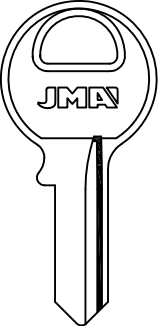
| TOMSK  | TOP   | TOVER  |  |
|--|---|--|--|
|           |                        |                       |           |
| <br>TOM-1 | <br>TOP-1<br>ABUS-NOVA | <br>TOV-1<br>TEICOCIL | <br>TOV-2 |

| TOVER  |  |  |  |
|--|--|--|--|
|            |                      |             |            |
| <br>TOV-3 | <br>TOV-4<br>TROMER | <br>TOV-5 | <br>TOV-6 |

| TOVER  | TRAVEX   | TRELOCK   |   |
|--|--|---|---|
|           |           |             |                      |
| <br>TOV-7 | <br>TRV-1 | <br>TRL-1.P | <br>TRL-2<br>HAMPTON |



## TRI-CIRCLE

PARA-FOR:  
TRI-CIRCLE (RC)

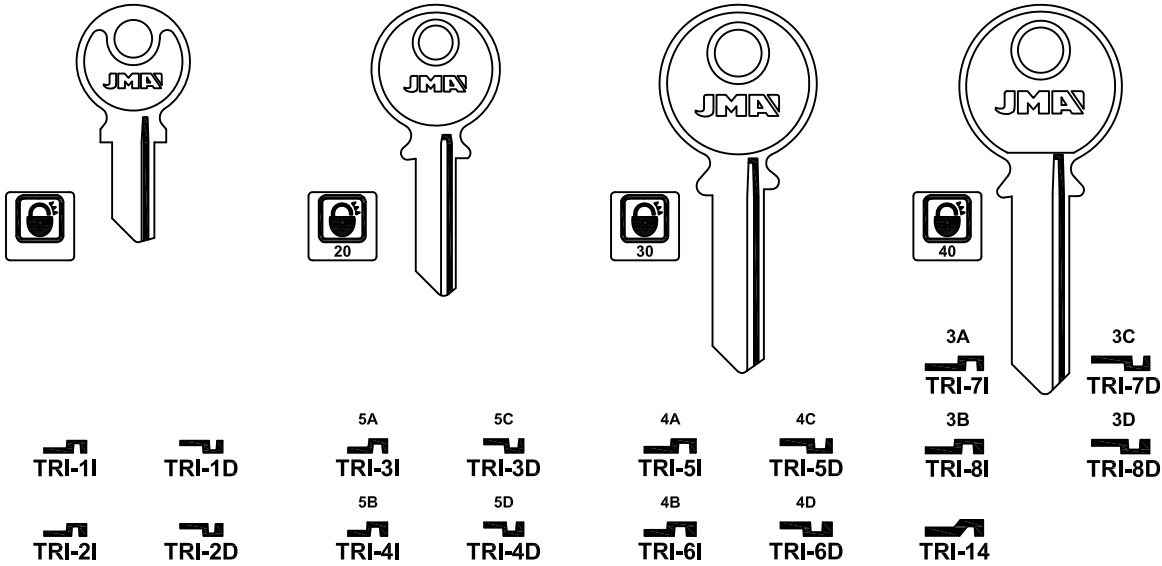

MARK

ELEPHANT

## TRI-CIRCLE

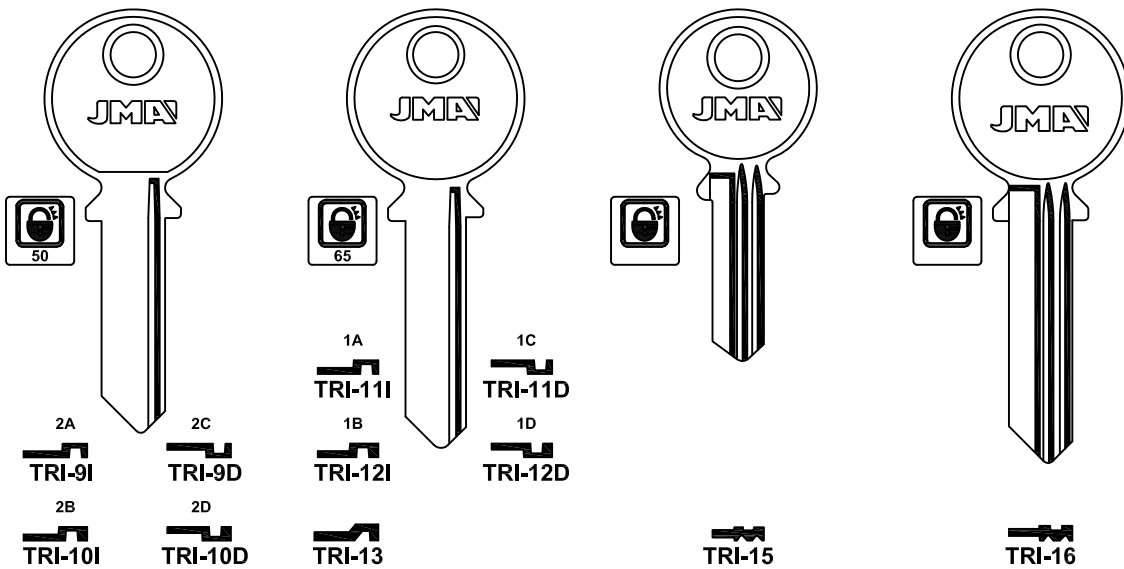

## TRI-CIRCLE

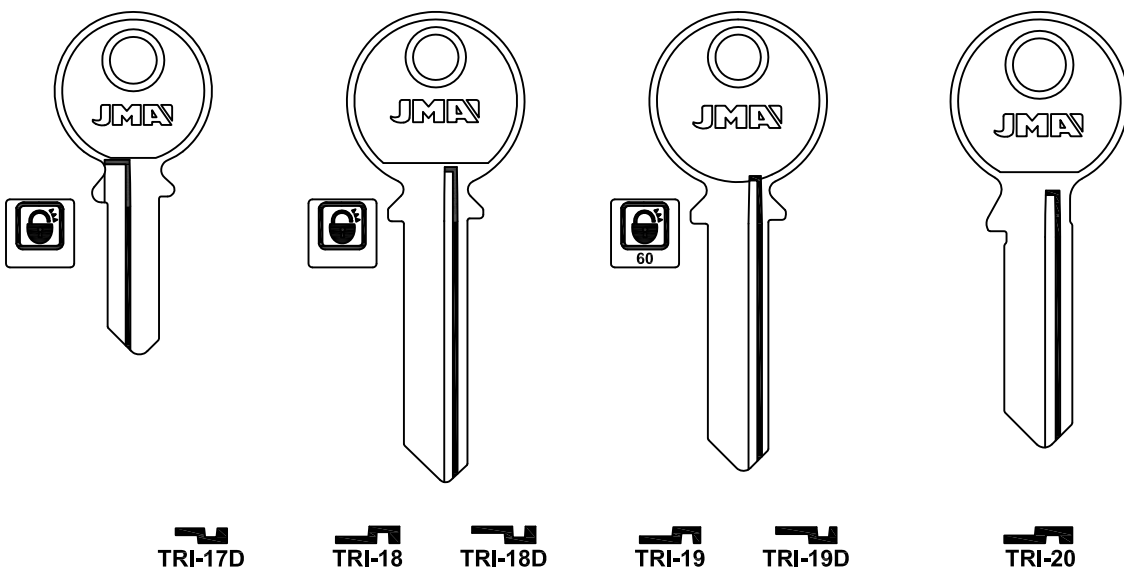







**PARA-FOR:**



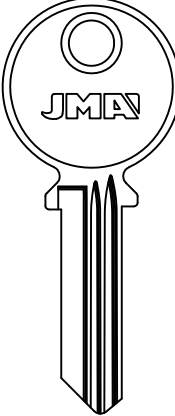
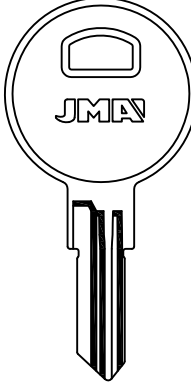
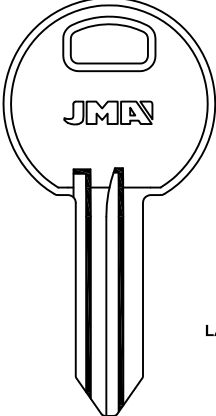
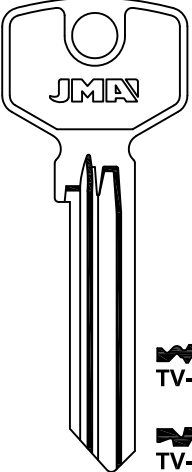



TRI STAR (RC)



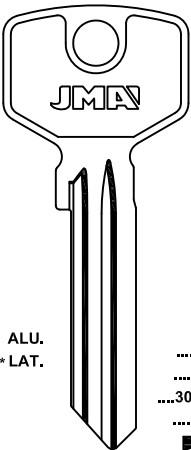
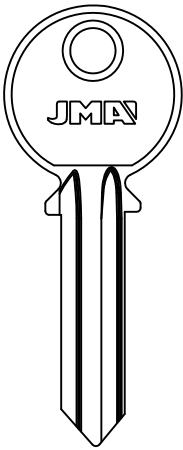
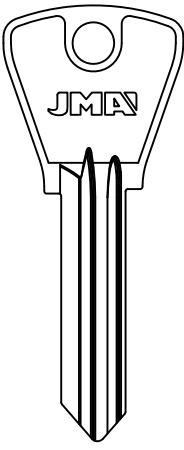
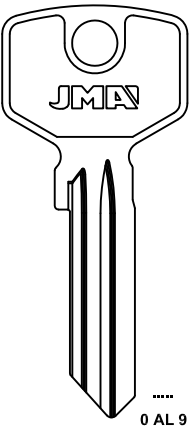







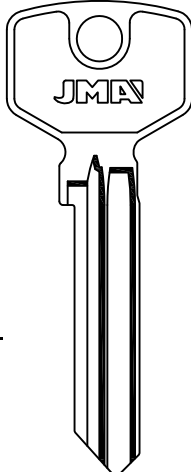

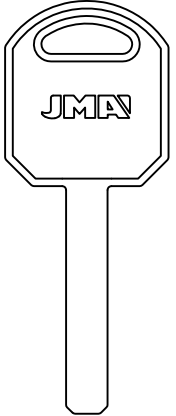

TRIMARK (USA)

TRIO-VING (N)







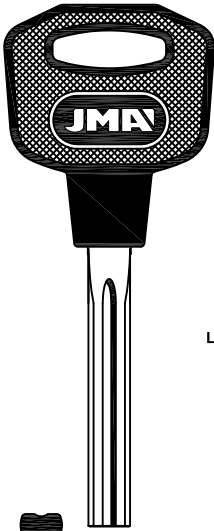

TRUPER (USA)

| TRI STAR  | TRIMARK   |   | TRIO-VING  |
|---|---|---|--|
|        |        |           |   |
|  TST-1 |  TRM-4 |  TRM-11D |  TV-13  |
|   | LAT.  | LAT.  |  TV-1D<br> TV-2D |

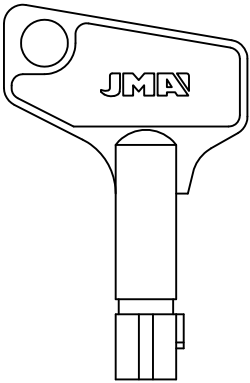

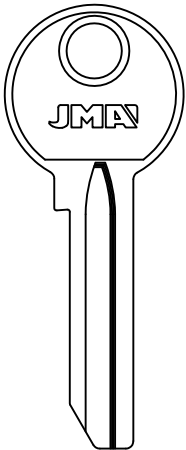

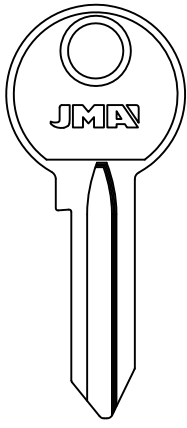



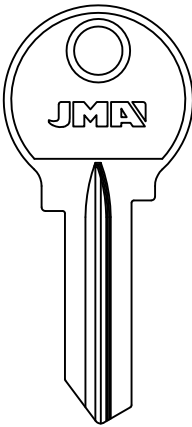

| TRIO-VING  |   |   |   |
|--|---|---|---|
|    |         |          |                             |
|  TV-4D  |  TV-11 |  TV-12 |  TV-16D                    |
| ALU.<br>*LAT.<br>.....1 AL 9<br>.....0 AL 9<br>...30000-56769<br>.....1-26770<br> TV-3D | ALU.  | ALU.  | .....<br>0 AL 9<br> TV-15D |
|  | TRIO  |   |   |

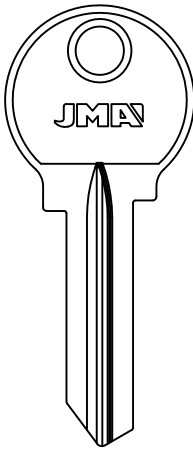

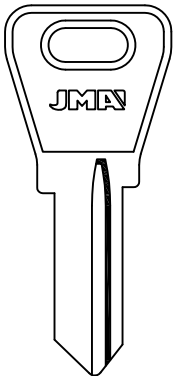

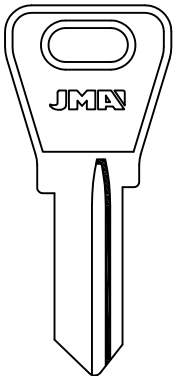

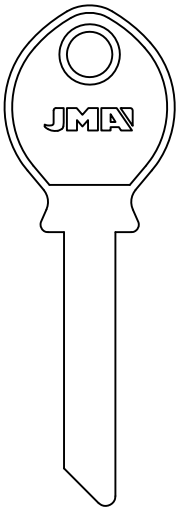

| TRIO-VING   | TRUPER   |  |   |
|---|--|--|---|
|  |  TV-17  |  TV-17D |        |
|   |  TV-18D |  |   |
|   |  TV-19D |  |   |
|   |  TV-20  |  |   |
|   |  TV-21  |  TV-32 |   |
|   |  TV-22  |  TV-22D |   |
| *LAT.   |  TV-23  |  TV-23D |  TV-30  |
|   |  |  |  TRU-7 |

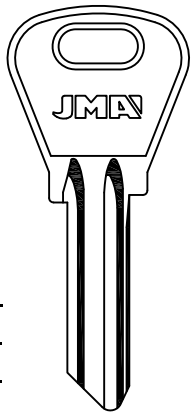
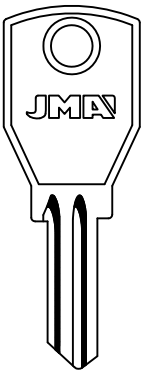
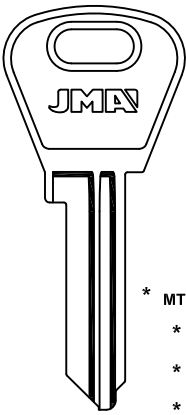
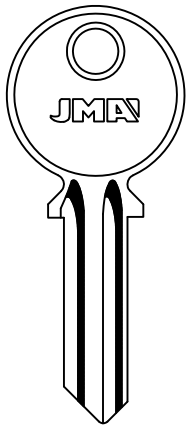

| TRUPER  | TSAG   | TULA  |   |
|---|--|---|---|
|  <p>LAT.</p>  <p>TRU-8.P</p> |  <p>J</p>  <p>SAG-1T</p> |   <p>TUL-1D</p> |   <p>TUL-2D</p> |

**PARA-FOR:**  
 TRUPER (USA)  
 TSAG (E)  
 TULA (RUS)  
 TUSHINO (RUS)  
 TZAFRER (GR)  
 UCEM (E)

| TUSHINO  |  | TZAFRER  |   | UCEM  |  |
|--|--|--|---|---|--|
|   <p>TUS-1D</p> |   <p>TUS-2D</p> |   <p>TZ-1</p> |   <p>TZ-1D</p> |   <p>5-L</p> |  |

| UCEM  |  |  |  |   |  |  |  |
|---|--|--|--|---|--|--|--|
|  <p>* ALU.<br/>* LAT.<br/>* FSH.</p> |                 |                 |               |  <p>UCEM-3</p> | <p>* MTIC.(V)<br/>* ALU.<br/>* LAT.<br/>* FSH.</p> |  <p>UCEM-12 *</p> |  <p>UCEM-4I</p> |
|  <p>* UCEM-1I</p>                     |  <p>UCEM-1D</p> |  <p>UCEM-2I</p> |  <p>UCEM-2D</p> | <p>CIB-ND</p>   | <p>CIB-ND</p>                                      | <p>STIQAM</p>  |  |



**PARA-FOR:**

- UCEM (E)
- ULIANOVSK (RUS)
- UMF (P)

**UCEM**

ALP.      ALP.      LAT. WNC.      ALP.

DEBEAURAIN      DEBEAURAIN

ESAFE      ESAFE

ISEO      ISEO

ND      ND

YEMAR      YEMAR

2.45      9      2.4      9      2.4      9      2.4      9

UCEM-5I      UCEM-5D      UCEM-7I      UCEM-7D      UCEM-8D      UCEM-8D.P

PENT

**UCEM**

ALP.      LAT.

9      9

2.4      2.4

UCEM-13D      UCEM-17D

PH

**ULIANOVSK**

UL-1      UL-2D

N

**ULIANOVSK**

UL-3      UL-4

**UMF**

UMF-1





# UNION

PARA-FOR:  
UNION (GB)

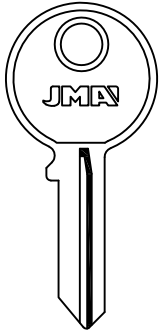

NRA  
FFE...1-100  
FJA...1-100  
FL...251-500  
NRA...51-90  
YFB...1-75  
FMD...1-75  
FG...1-30  
NF...1-30  
EJR...1-75



UN-FFE

UN-3

FP...  
626-750  
UN-FP

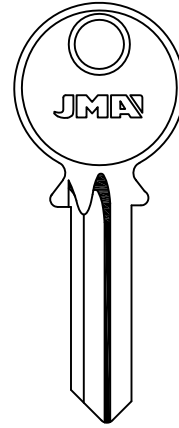
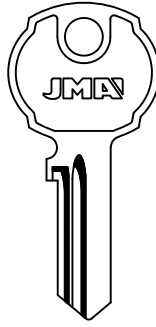

MC...1-40  
MRA...251-290  
MRN...1-54  
MRN...201-250  
MRN...251-300

UN-MRN

HX...100  
UN-2

FR...  
751-875  
UN-FR

FS...1-99  
FS...876-955

UN-1FS

FA...  
501-625

UN-44

RM...  
911-952

UN-44D

NGN...1-54

UN-NG

KB53A

UN-5D

KB506

UN-6D

BRITISH LEYLAND-FORD-HILLMAN-JAGUAR-LAND ROVER-MG-MORRIS-ROVER

# UNION

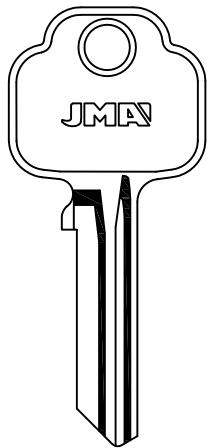

503  
UN-12I  
574  
UN-13I  
575  
UN-14I  
576  
UN-15I  
577  
UN-16I  
578  
UN-17I  
579  
UN-18I

UN-7I

581  
UN-19I  
582  
UN-20I  
583  
UN-21I  
584  
UN-22I  
585  
UN-23I  
586  
UN-24I  
587  
UN-25I  
588  
UN-26I  
589  
UN-27I

914  
UN-13D  
915  
UN-14D  
916  
UN-15D  
917  
UN-16D  
918  
UN-17D  
919  
UN-18D

UN-7D

901  
UN-19D  
902  
UN-20D  
903  
UN-21D  
904  
UN-22D  
905  
UN-23D  
906  
UN-24D  
907  
UN-25D  
908  
UN-26D  
909  
UN-27D

# UNION

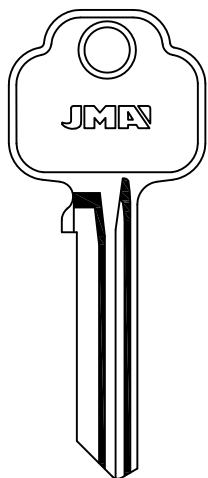

503  
UN-28I  
574  
UN-29I  
575  
UN-30I  
576  
UN-31I  
577  
UN-32I  
578  
UN-33I  
579  
UN-34I

UN-8I

581  
UN-35I  
582  
UN-36I  
583  
UN-37I  
584  
UN-38I  
585  
UN-39I  
586  
UN-40I  
587  
UN-41I  
588  
UN-42I  
589  
UN-43I

914  
UN-29D  
915  
UN-30D  
916  
UN-31D  
917  
UN-32D  
918  
UN-33D  
919  
UN-34D

UN-8D

901  
UN-35D  
902  
UN-36D  
903  
UN-37D  
904  
UN-38D  
905  
UN-39D  
906  
UN-40D  
907  
UN-41D  
908  
UN-42D  
909  
UN-43D

**JMA**®

Copyright by Alejandro Altuna S.A. 2014



ATENCIÓN: Concerniente a las marcas y denominaciones comerciales ver nota en índice.  
ATTENTION: Concerning the marks and commercial denominations see note in index.  
ATTENTION: Concernant les marques et dénominations commerciales voir la note dans l'index.  
ACHTUNG: Beziehen auf die marke und handelsname sehen sie die notiz im index.

**PARA-FOR:**

UNION (GB)

UNIVERSAL

**UNION**

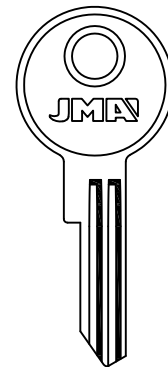
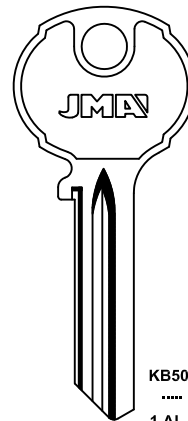
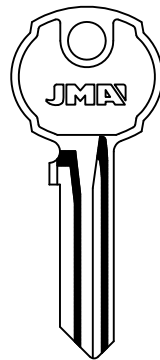
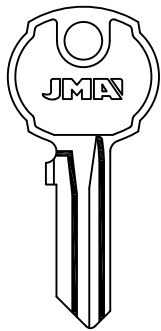

UN-9I



UN-9D



UN-10I



UN-10D

KB502  
.....  
1 AL 6  
 UN-11



UN-45D

KB682  
 UN-46D

ONIUM

**UNION**

**UNIVERSAL**

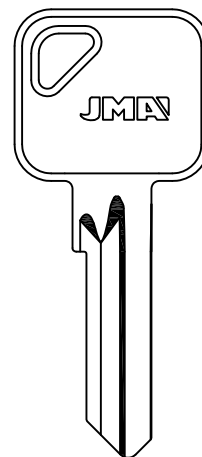
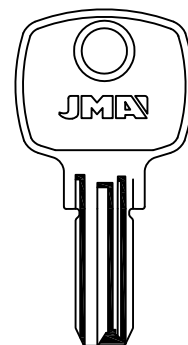
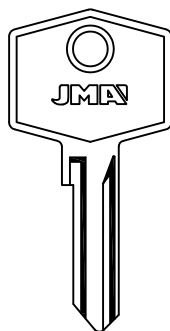
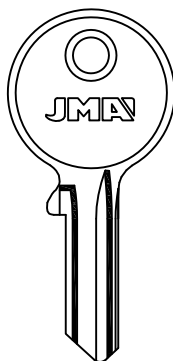

TBS...1-50  
NKL...1-150  
NND...1-150  
TBS...1-500  
TBS...201-350



UN-47



FK...  
01-99  
876-955



UN-FK

FS...  
01-99  
876-955



UN-FS

JAGUAR-VAUXHALL

LAT.

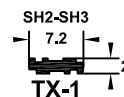

SH2-SH3  
7.2  
2  
TX-1



TX-3D

EURO SPEC

**UNIVERSAL**

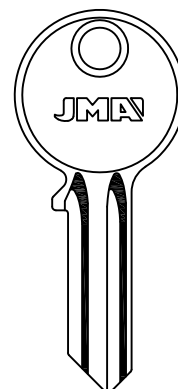
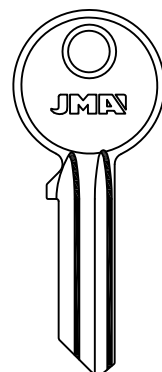
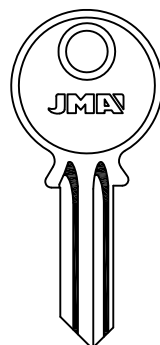
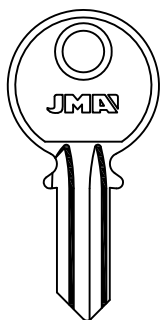

U-1I



U-1D



U-2I



U-2D



U-3I



U-3D



U-4I



U-4D

ALU.

TECNO



UNIVERSAL

PARA-FOR:  
UNIVERSAL

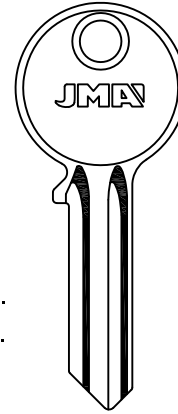
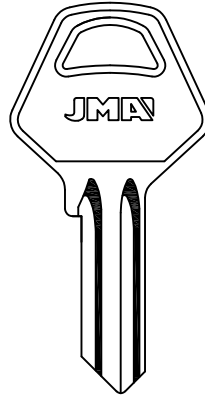
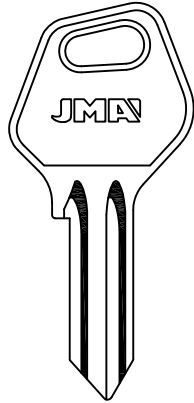
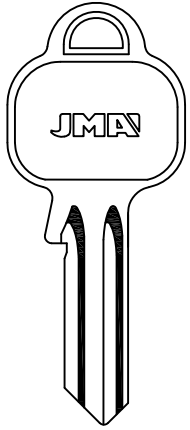

ALU.  
\* FSH.

U-4AI

U-4AD

U-4JI

U-4JD

U-4TI

U-4TD

U-5I

\* U-5D

ESAFE-SIL

UNIVERSAL

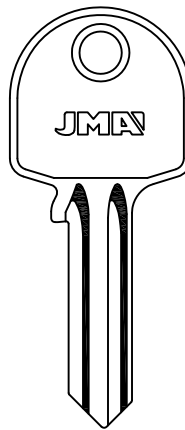
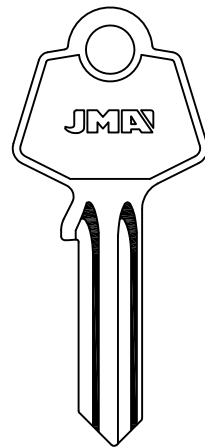
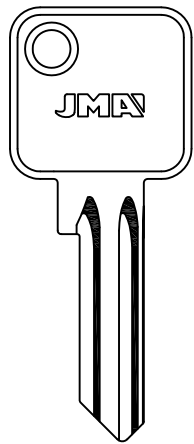
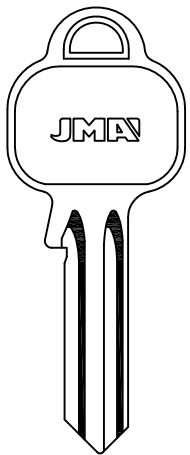

U-5AI

U-5AD

U-5BI

U-5BD

U-5CI

U-5CD

U-5DI

U-5DD

UNIVERSAL

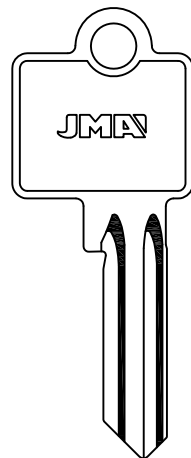
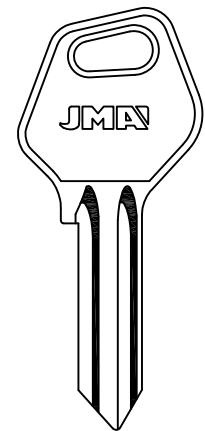
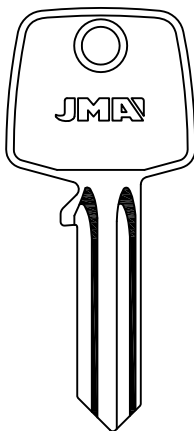
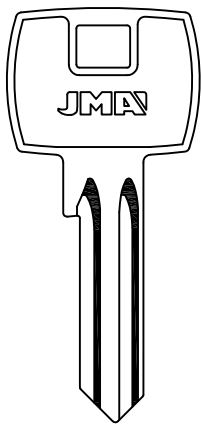

U-5EI

U-5ED

U-5FI

U-5FD

U-5JI

U-5JD

U-5KI

U-5KD



PARA-FOR:  
UNIVERSAL

UNIVERSAL

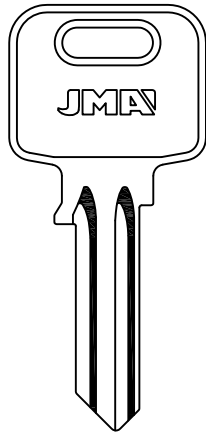

U-5MI

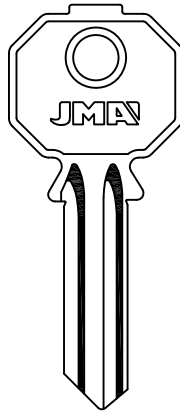

U-5MD

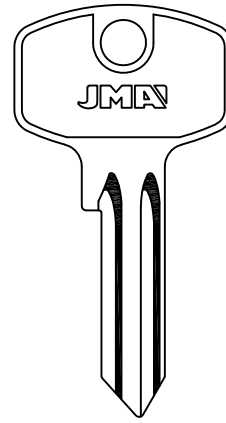

U-5PI

U-5PD

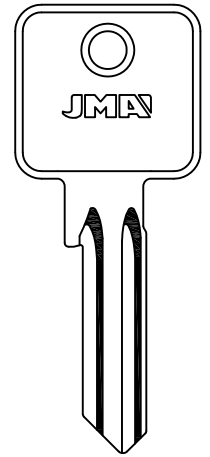

U-5QI

U-5QD

U-5SI

U-5SD

UNIVERSAL

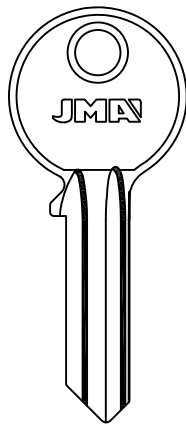

U-5SP

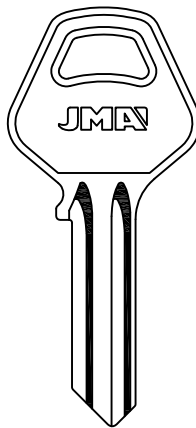

U-5DSP

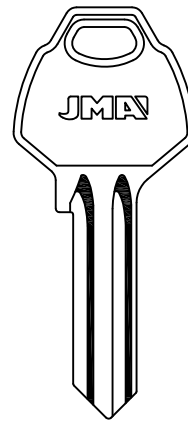

U-5TI

U-5TD

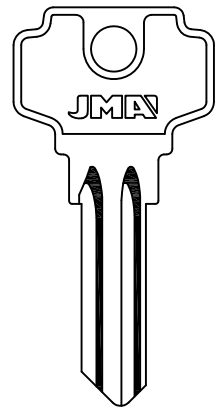

U-5VI

U-5VD

U-5XI

U-5XD

UNIVERSAL

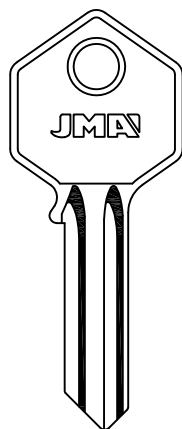

U-5YI

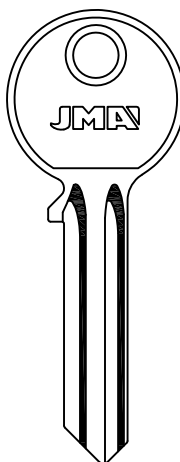

U-5YD

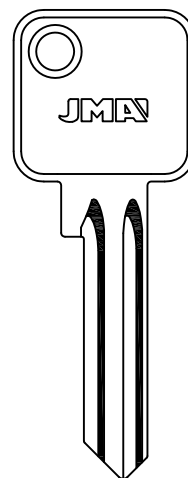

U-6I

U-6D

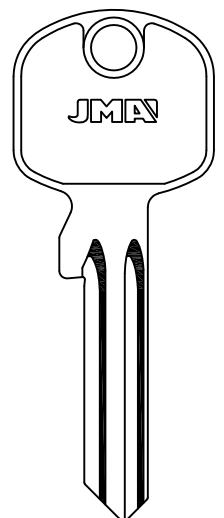

U-6BD

U-6GD

ALU.



UNIVERSAL

PARA-FOR:  
UNIVERSAL

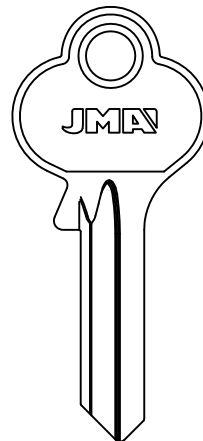
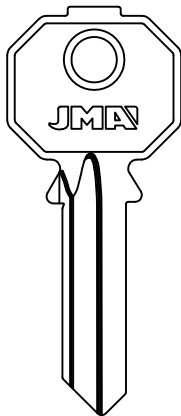
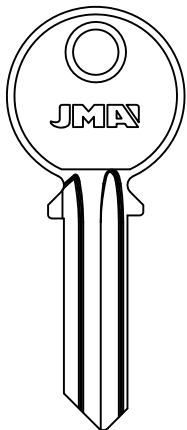
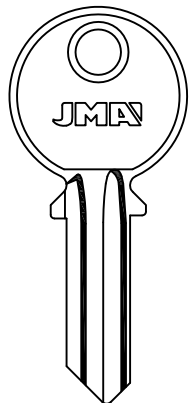

LAT.



TVO-1D

UNIVERSAL

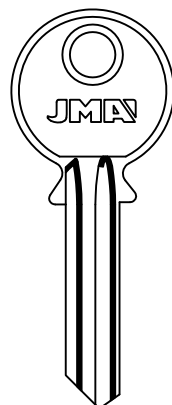
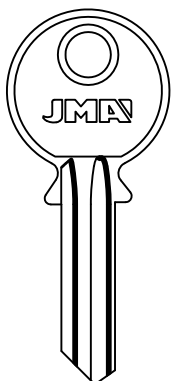
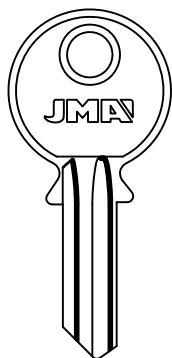
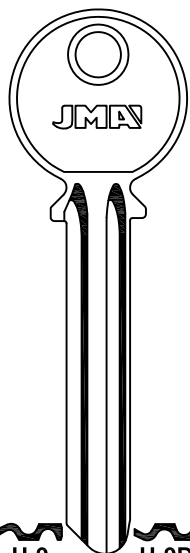

TVO-3D

TVO-2D

UNIVERSAL

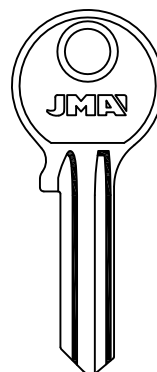
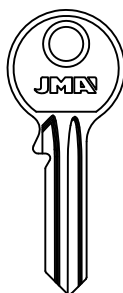
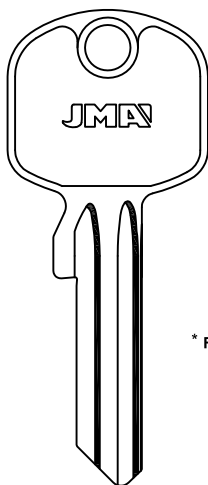
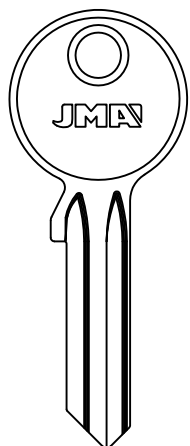

MTIC.

\* FSH.



TVO-4D

CISA LOGO



**PARA-FOR:**

UNIVERSAL

URBIS (R)

URKO (E)

**UNIVERSAL**

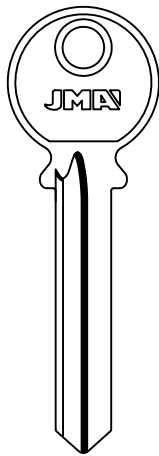

U-18D

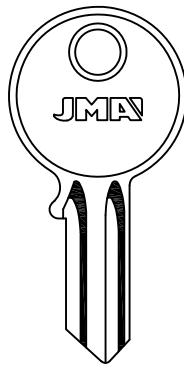

U-19

U-19D

LAT.

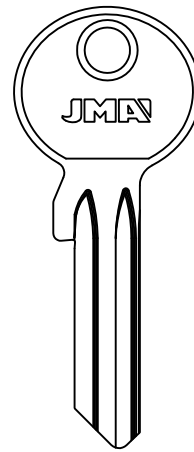

U-21

U-21D

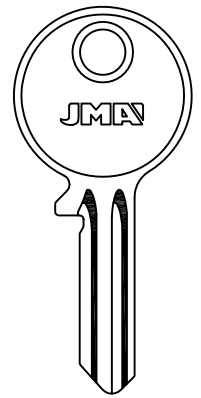

U-22

U-22D

**UNIVERSAL**

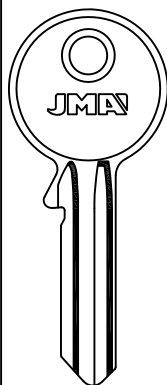

U-25

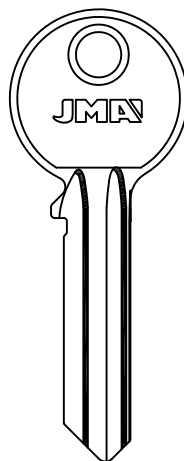

U-25D

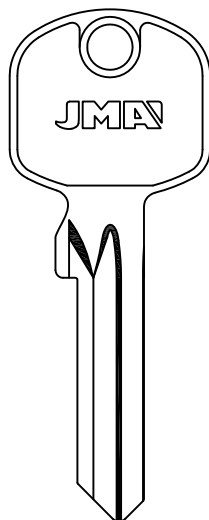

U-26

U-26D

U-26GD

**URBIS**

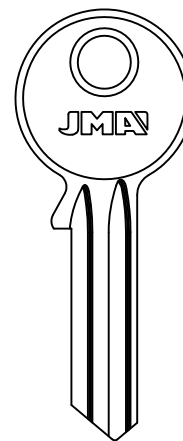

URB-1

URB-1D

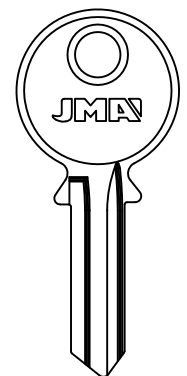

URB-2

**URBIS**

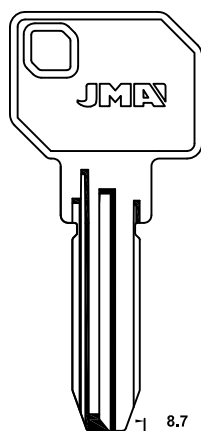

LAT.

URB-3D

URB-4D

BANE SEKULIC

**URKO**

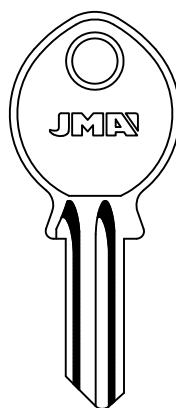

URKO-11

URKO-1D

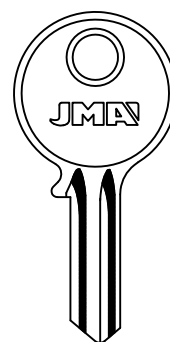

URKO-21

URKO-2D

URKO-31

URKO-3D

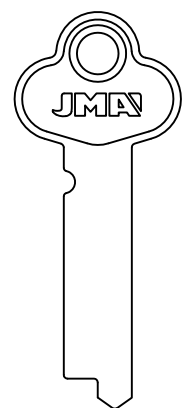

URKO-4



# VACHETTE

PARA-FOR:  
VACHETTE (F)

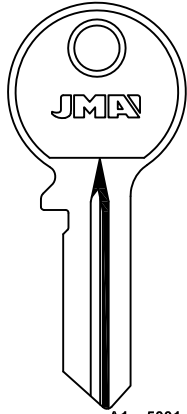

A1...5001-5631



BAU-FONTAINE-HEMA-LAPERCHE  
METALUX-MODERN-STREMLER



A...5000-5635

AY...0-249

Y...0-249

AS...0-099

S...0-099

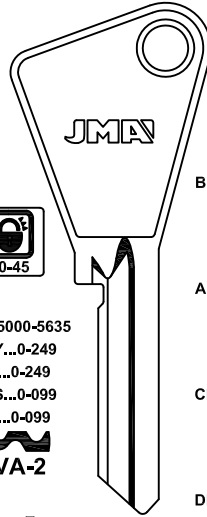

BM...870-894



AM...870-894



CM...870-894



DM...870-894

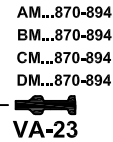

AM...870-894

BM...870-894

CM...870-894

DM...870-894

# VACHETTE

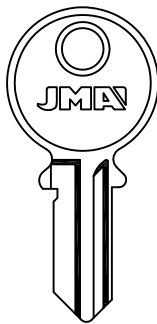

...1 AL 9 AL 0

E...9001-9100

...R9001-9100



ISEO-KLIT

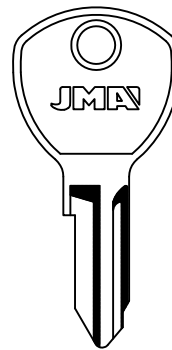

G...0-423



W...0-423



ATAL-VINCO

# VACHETTE

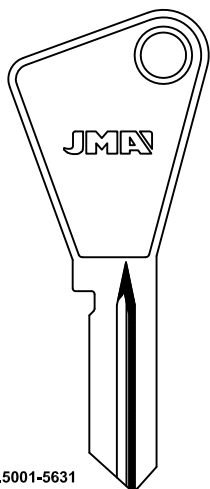

A1...5001-5631  
UL...1-3500  
U...1 AL 9 AL 0



RA-KA



RB-KB



RC-KC



RE-KE



RF-RK



RG-KG



RJ-KJ



RK-KK



RL-KL



RD



RDH



RDM



RHM



RM



RN



RK



LD



LN



LH



DHP



LA-AK



LA-BK



LC-CK



LE-EK



LF-FK



LG-GK



**PARA-FOR:**  
VACHETTE (F)

**VACHETTE**

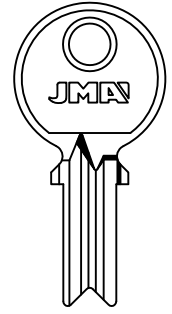
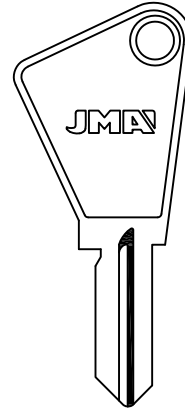
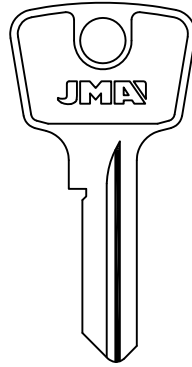
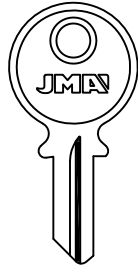

VA-9D

RUKA



VA-12D

TRELOCK

EE...9001-9100

VA-14D

VA-15

**VACHETTE**

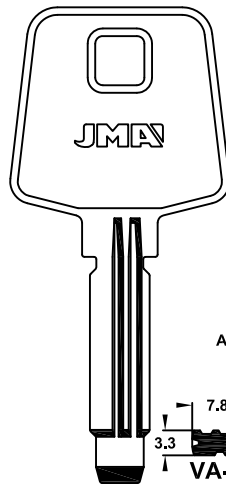
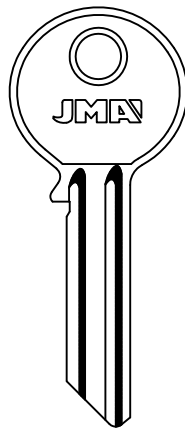

ALP.

VA-25

VA-24I

VA-24D

VA-26

RADIAL

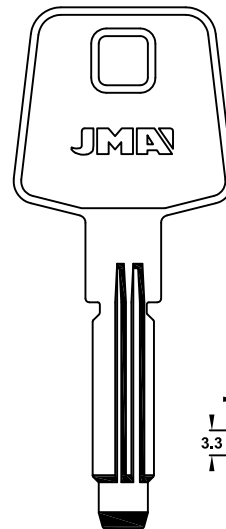

VA-27

VA-28

RADIAL

VA-56

ALP.

**VACHETTE**

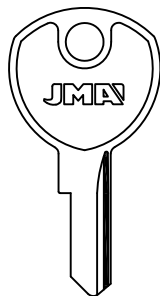

VL...A0-H9

VA-29

RL...A0-H9

VA-35

DAD-JU

WL...A0-H9

VA-29D

K...A0-H9

BL...A0-H9

VA-35D

VA-62

VA-62D

VINCO

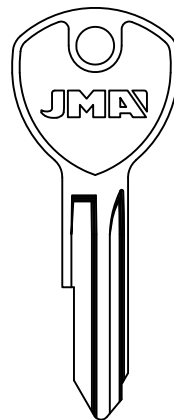

VA-30

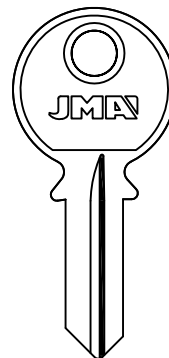

40-50-60

.....

1 AL 8

VA-31D

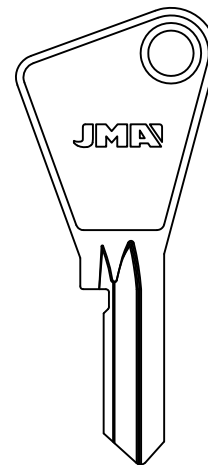

AY...0-249

Y...0-249

VA-32D

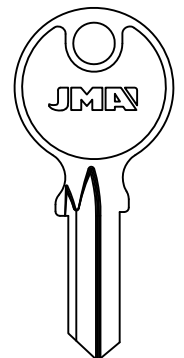

VA-33D





# VACHETTE

PARA-FOR:  
VACHETTE (F)

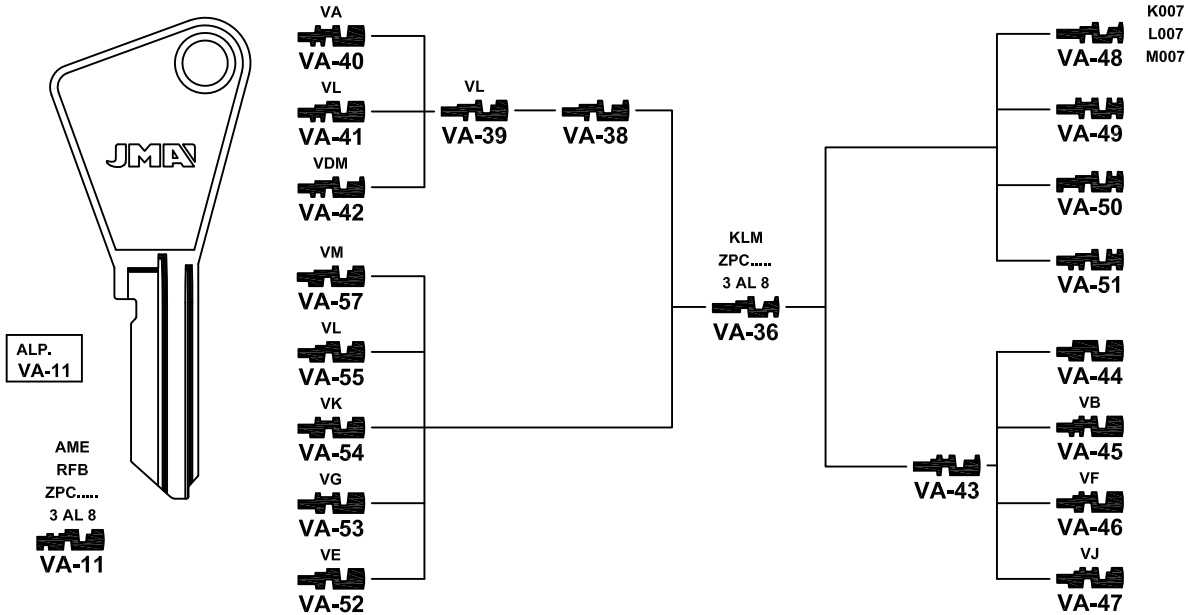

# VACHETTE

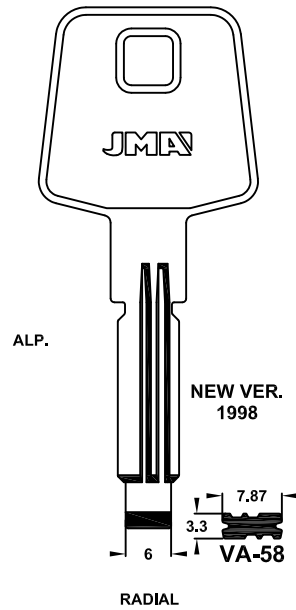
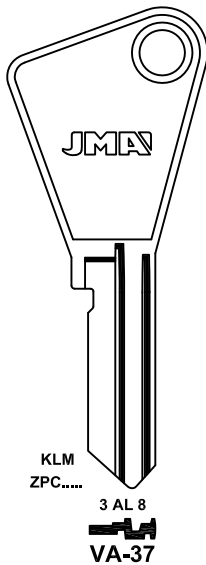

# VACHETTE

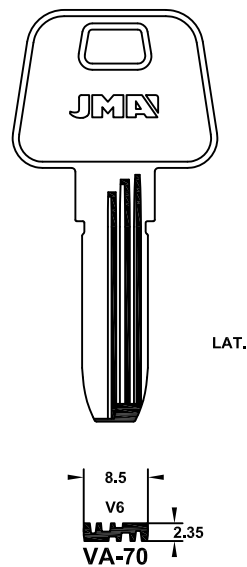
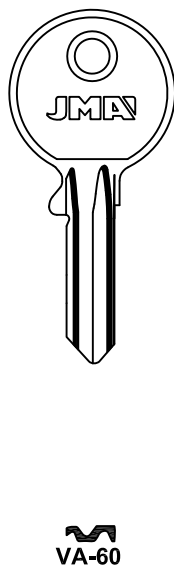
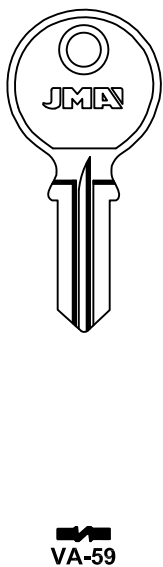

SANPEUR



**PARA-FOR:**

- VARIOS
- VBH (D)
- VEGA (F)
- VENDI (RO)

**VARIOS**

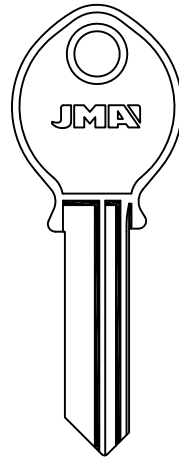

6-C

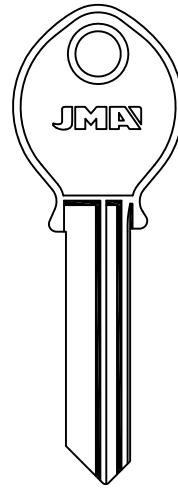

6-L

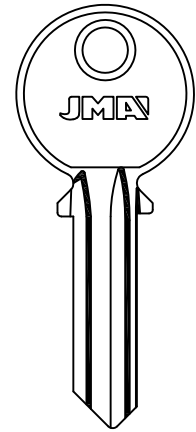

35-I

35-D

38-I

38-D

FAC

**VARIOS**

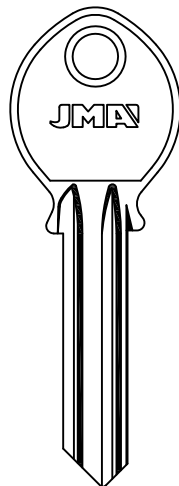

JMA-1I

JMA-1D

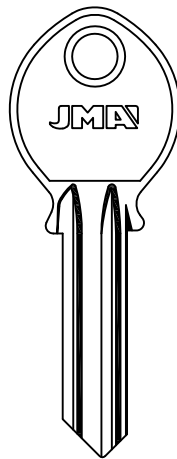

JMA-2I

JMA-2D

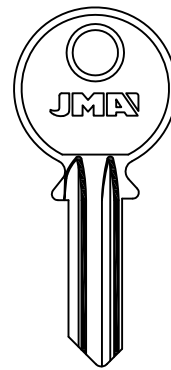

JMA-3I

JMA-3D

RONEO-JCEM

JMA-4I

JMA-4D

BOMORO

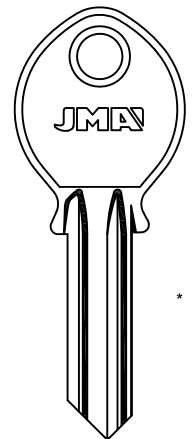

JMA-9I

\* JMA-9D

\* LAT.  
ALU.

**VBH**

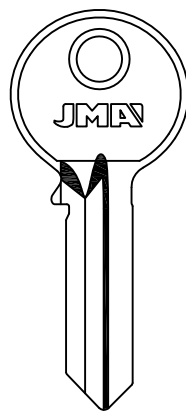

VB-1D

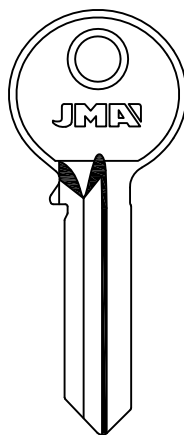

VB-2D

**VEGA**

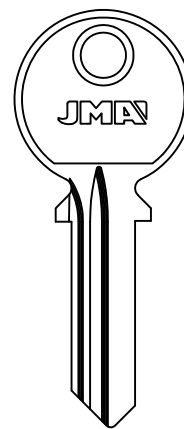

VE-1D

VACHETTE

**VENDI**

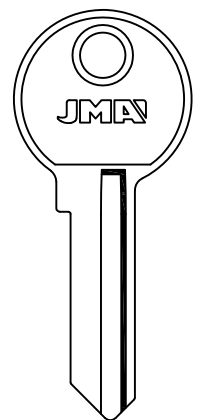

VND-1

VND-1D

VND-2

VND-2D



| VENDI | VGF VILLATORE |  | VING |
|-------|---------------|--|------|
|       |               |  |      |
|       |               |  |      |

**PARA-FOR:**  
 VENDI (RO)  
 VGF VILLATORE (I)  
 VING (N)  
 VIRO (I)

| VIRO                  |                 |                   |             |
|-----------------------|-----------------|-------------------|-------------|
|                       |                 |                   |             |
| ** ALU.<br>* LAT.     |                 | ** ALU.<br>* LAT. |             |
|                       |                 |                   |             |
| .....<br>0 AL 6       | .....<br>0 AL 6 | .....0 AL 5       | .....012345 |
| ** VI-1I              | * VI-12         | ** VI-2I          | * VI-15     |
| ABUS-BERAM-ROYAL-TESA |                 | ABT               |             |









| VIRO        |     |             |                 |
|-------------|-----|-------------|-----------------|
|             |     |             |                 |
|             |     |             |                 |
|             |     |             |                 |
| .....0 AL 5 |     | .....<br>20 | .....<br>0 AL 7 |
| ABUS-ROYAL  | ABT | ABUS-BURG   | SPECIAL         |

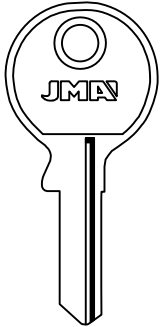

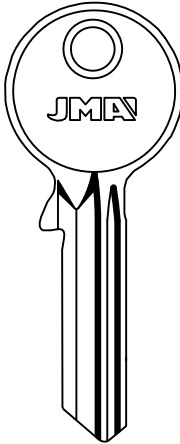

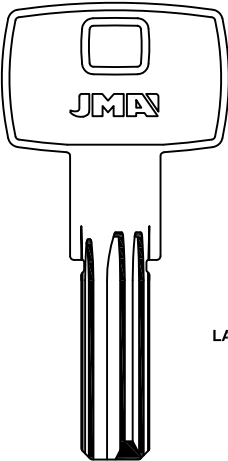

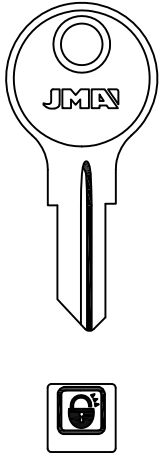



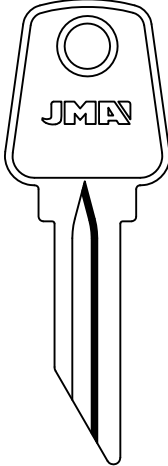

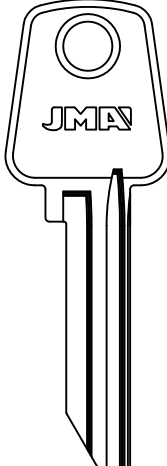

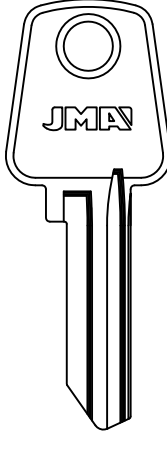

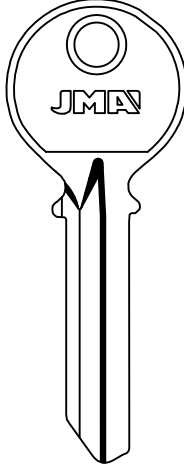



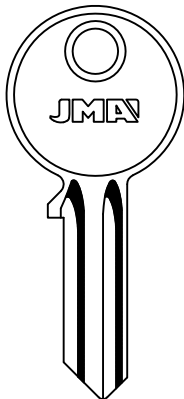

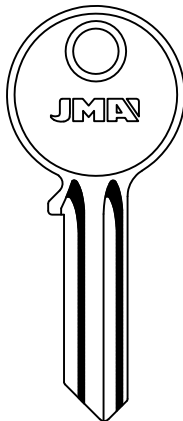

**PARA-FOR:**

- VIRO (I)
- VOLGOGRAD (RUS)
- VOLKOVYSK (RUS)
- WALLY (RC)
- WALRUS (RC)

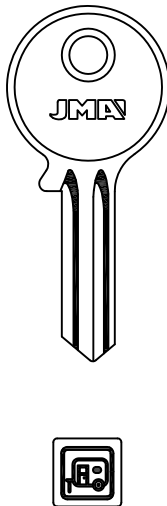



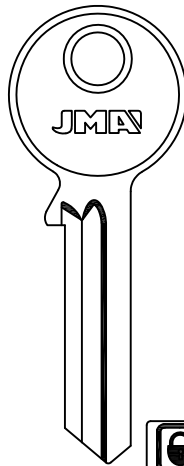



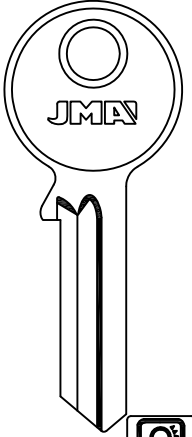

**VIRO**

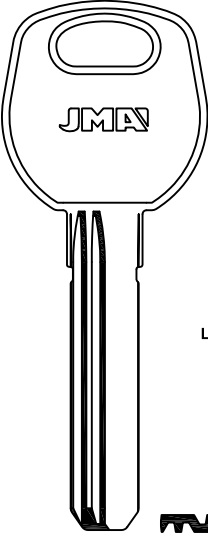
|  |  |  |  |   |
|--|--|--|--|---|
| <br><br><b>VI-10</b> | <br><br><b>VI-11</b> | <br><b>VI-11D</b> | <br><br><b>VI-14</b><br><small>EURO-PRO</small> | <br><br><b>VI-16D</b><br><small>FAI</small> |
|--|--|--|--|---|

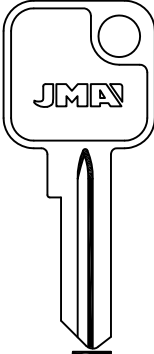
| <b>VOLGOGRAD</b>  | <b>VOLKOVYSK</b>  |   | <b>WALLY</b>  |
|---|---|---|---|
| <br><br><b>VG-1D</b> | <br><br><b>VLK-1</b> | <br><br><b>VLK-2</b> | <br><br><b>WA-1D</b> |



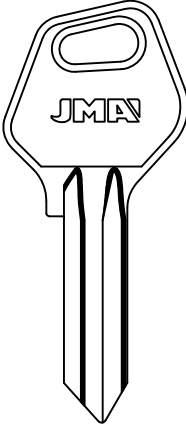





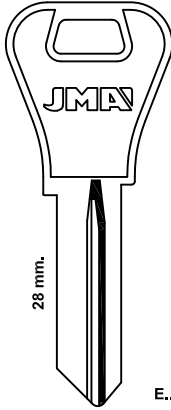

| <b>WALLY</b>   |  |  | <b>WALRUS</b>   |
|--|--|--|---|
| <br><br><b>WA-4I</b>     | <br><br><b>WA-4D</b> | <br><br><b>WA-5I</b> | <br><br><b>WA-5D</b>      |
| <br><br><b>WA-5IP</b> |  |  | <br><br><b>WA-5DP</b> |
| <b>MOREAUX</b>   |  |  | <br><br><b>WAL-1D</b> |

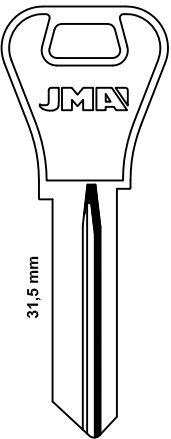

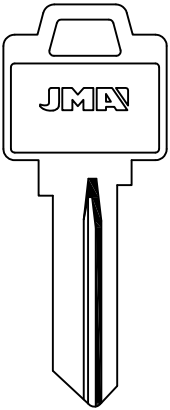

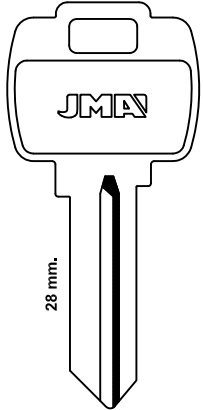

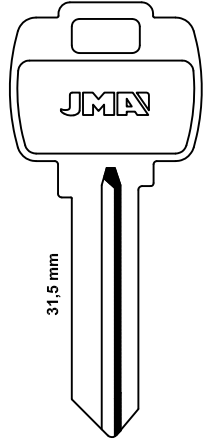

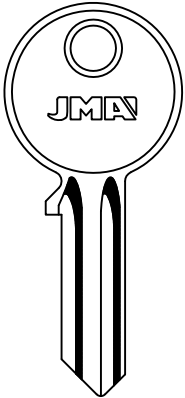

| WALRUS   | WANJIN   | WEBER   | WEBSTER   |
|--|--|---|---|
|  <p>JMA</p>  <p>WAL-2D</p> |  <p>JMA</p> <p>LAT.</p>  <p>WAN-1D</p> |  <p>JMA</p>  <p>WEB-1</p>  <p>WEB-2</p>  <p>WEB-3</p> <p>WECO</p> |  <p>JMA</p>  <p>WBS-1</p> |

**PARA-FOR:**  
WALRUS (RC)  
WANJIN (PRC)  
WEBER (D)  
WEBSTER (GB)  
WEISER (USA)  
WELKA (I)  
WESLOCK (USA)

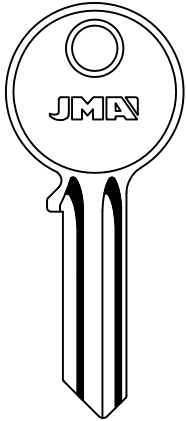
**WEISER**

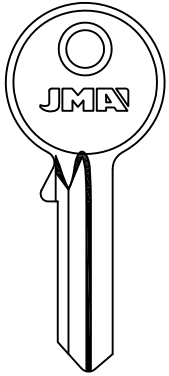
|  |  |  |   |   |
|--|--|--|---|---|
|  <p>JMA</p> <p>28 mm.</p>  <p>WEI-1</p>  <p>WEI-6</p> <p>KAWE</p> |  <p>JMA</p> <p>31,5 mm</p>  <p>WEI-2</p> <p>FALCON-FICHET</p> |  <p>JMA</p>  <p>WEI-3</p> <p>IDEAL SECURITY</p> |  <p>JMA</p> <p>28 mm.</p>  <p>WEI-4</p> <p>FALCON</p> |  <p>JMA</p> <p>31,5 mm</p>  <p>WEI-5</p> <p>FALCON</p> |
|--|--|--|---|---|

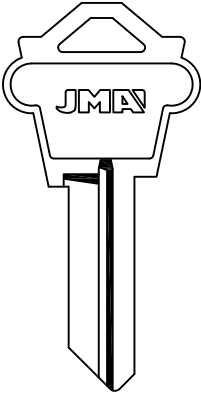
**WELKA**      **WESLOCK**

|   |  |   |  |
|---|--|---|--|
|  <p>JMA</p>  <p>WE-4I</p>  <p>WE-4D</p> |  <p>JMA</p>  <p>WE-5I</p>  <p>WE-5D</p> |  <p>JMA</p>  <p>WE-6D</p> |  <p>JMA</p>  <p>WES-1D</p> |
|---|--|---|--|



**PARA-FOR:**

WESTLOCK (USA)

WHITCO (AUS)

WILKA (D)

| WEST LOCK                     |                               | WHITCO                         | WILKA                         |
|-------------------------------|-------------------------------|--------------------------------|-------------------------------|
|                               |                               |                                |                               |
| V....<br>1 AL 6<br><br>WST-1D | V....<br>1 AL 6<br><br>WST-2D | .....0123456789A<br><br>WHI-1D | .....<br>1 AL 9<br><br>WIL-1D |
|                               |                               | LAT.                           | ALU.                          |
|                               |                               |                                | WIL-7<br>JORE-WIGRO           |

**WILKA**

|            |            |                               |                              |                               |
|------------|------------|-------------------------------|------------------------------|-------------------------------|
|            |            |                               |                              |                               |
| <br>WIL-2D | <br>WIL-3D | .....<br>1 AL 9<br><br>WIL-4D | .....<br>1 AL 9<br><br>WIL-5 | .....<br>1 AL 9<br><br>WIL-5D |
|            | CFP-GBS    | JORE-WIGRO                    |                              |                               |
|            |            | MTIC.                         |                              |                               |

**WILKA**

|  |                |           |           |           |           |           |           |
|--|----------------|-----------|-----------|-----------|-----------|-----------|-----------|
|  | * WIL-26       | * WIL-33D | * WIL-40D | * WIL-48D | * WIL-55  | * WIL-62  |           |
|  | * WIL-25       | * WIL-32  | * WIL-39D | * WIL-47D | * WIL-54  | * WIL-61  |           |
|  | W101<br>WIL-24 | * WIL-31D | * WIL-38D | * WIL-46D | * WIL-53  | * WIL-60D |           |
|  | WIL-19D        | * WIL-30  | * WIL-37D | * WIL-45D | * WIL-52  | * WIL-59D |           |
|  | WIL-18         | * WIL-29  | * WIL-36D | * WIL-44  | WIL-51D   | * WIL-58D |           |
|  | * WIL-9        | * WIL-28  | * WIL-35D | * WIL-43D | * WIL-50D | * WIL-57D | WIL-65D   |
|  | WIL-8          | * WIL-27  | * WIL-34D | * WIL-41D | * WIL-49D | * WIL-56  | * WIL-63D |

\* LAT.



## WILKA

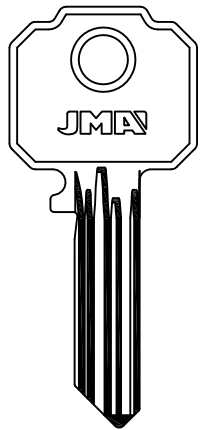

  
WIL-14

  
WIL-15

  
WIL-12

  
WIL-13

  
WIL-10

  
WIL-11

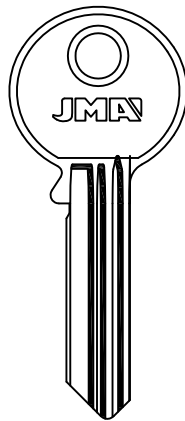

  
WIL-16

  
WIL-17D

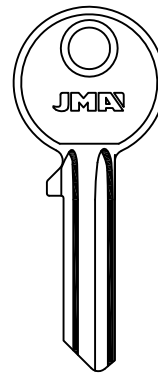

  
WIL-20

## PARA-FOR:

WILKA (D)

WINDHAUS (D)

WINLOCK (GB)

WIREROPE (HK)

## WILKA

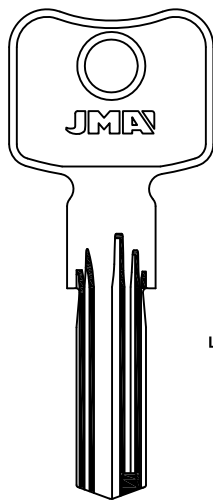

SERIE 3600

LAT.

LAT.

  
WIN-11

ALP.

  
WIN-1D

  
WIN-2D

  
WIN-3D

AZBE

## WINKHAUS

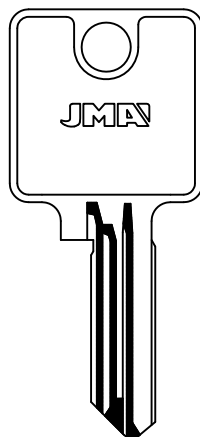

ALP.

  
WIN-4D

AZBE

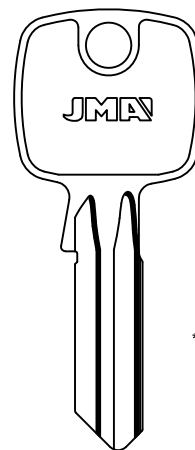

\* ALP.  
ACE.

  
\* WIN-5

  
WIN-5D

## WINKHAUS

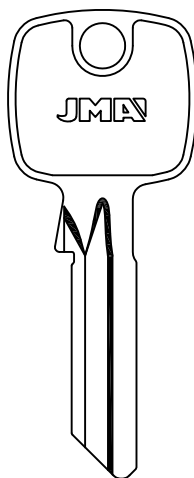

  
WIN-6D

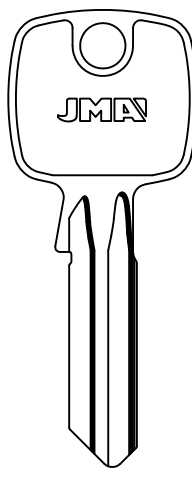

  
WIN-21

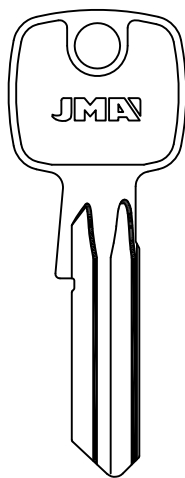

  
WIN-22

## WINLOCK

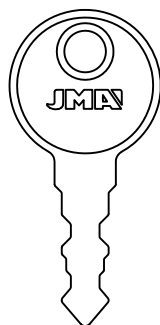

  
WNC-1

## WIREROPE

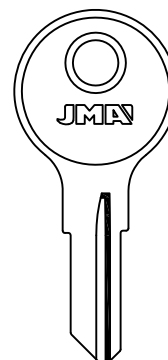

  
WIR-1



**PARA-FOR:**

WMS (GB)

WT (TJ)

YALE  
(D-GB-USA)

**WMS**

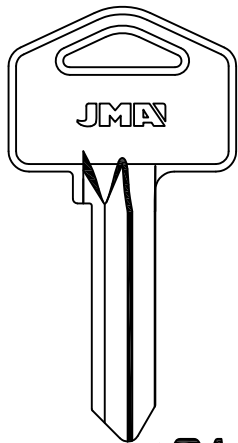

WM-1D

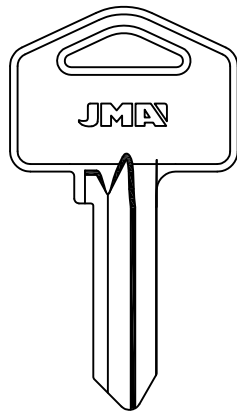

WM-2D

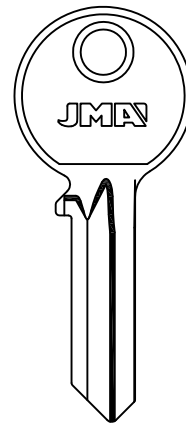

WM-3D

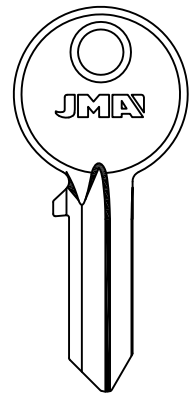

WM-4D

WM-5D

I.R.-TITUS

**WT**

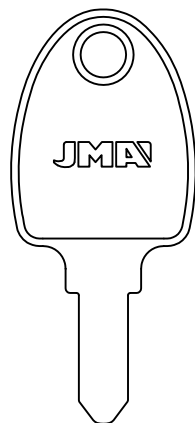

LAT.

WT-1

**YALE**

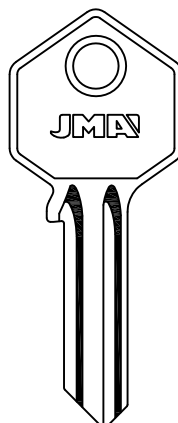

ALU.



YA-1I



YA-1D

....0 AL 9



YA-32D

WALE

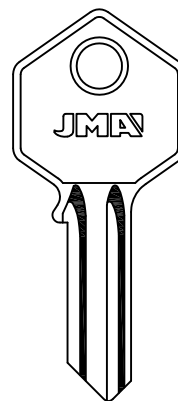

ALU.



YA-2I



YA-2D

....0 AL 9

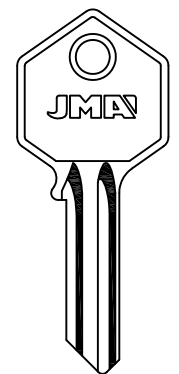

....0 AL 9



YA-3I



YA-3D

WALE

**YALE**

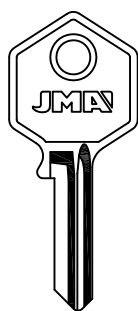

YA-5I

YA-5D

MIGNON

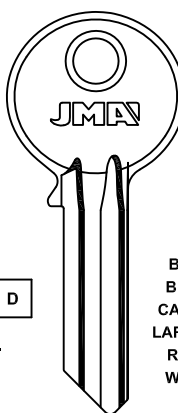

ALU.



YA-6I



YA-6D

....0 AL 9

BKS  
BIRD  
CARAT  
LAREDO  
ROC  
WOC

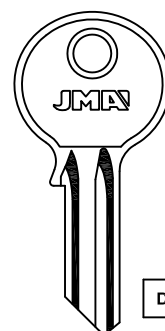

D

GB



YA-7I



YA-7D

R..101-150

SX...1-1000

VR...1-4000

BX...1-500

YA-16D

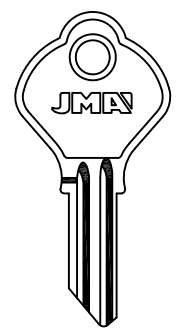

GB



YA-8I



YA-8D

DC...551-952



YA-8I



YA-8D





# YALE

PARA-FOR:

YALE  
(D-GB-USA)

Key 1: JMA logo, GB code.  
 Key 2: JMA logo, USA GB codes, ABUS, BENDIX, CAB, CHICAGO, COLE HERSEE, ALU. codes.  
 Key 3: JMA logo, D GB codes, ABG... 7537-8336 code.

Key 1 profiles: LT...1-100, LC...1-100, YA-10, YA-10D.  
 Key 2 profiles: YA-11I, YA-11D.  
 Key 3 profiles: YA-12I, YA-12D, YA-13I, YA-13D.

BKS

# YALE

Key 1: JMA logo, D GB codes, YA-17I, YA-17D, YA-26I, YA-29, YA-14I, YA-14D, YA-39, YA-39D.  
 Key 2: JMA logo, D GB codes, YA-15I, YA-15D.  
 Key 3: JMA logo, ALU. code, YA-22I, YA-22D.

Key 1 profiles: Y, L, PBS, Y, L, .....0 AL 9.  
 Key 2 profiles: Y, L.  
 Key 3 profiles: .....0 AL 9.

# YALE

Key 1: JMA logo, ALP. code, YA-23.  
 Key 2: JMA logo, ALU., \* FSH. codes, YA-24I, YA-24D.  
 Key 3: JMA logo, D GB codes, YA-25I, YA-25D.  
 Key 4: JMA logo, USA GB codes, ABUS, BENDIX, CAB, CHICAGO, COLE HERSEE, YA-27, YA-27D.

Key 2 profiles: .....0 AL 9.  
 Key 4 profiles: ...500-550.



**PARA-FOR:**

YALE  
(D-GB-USA)

**YALE**

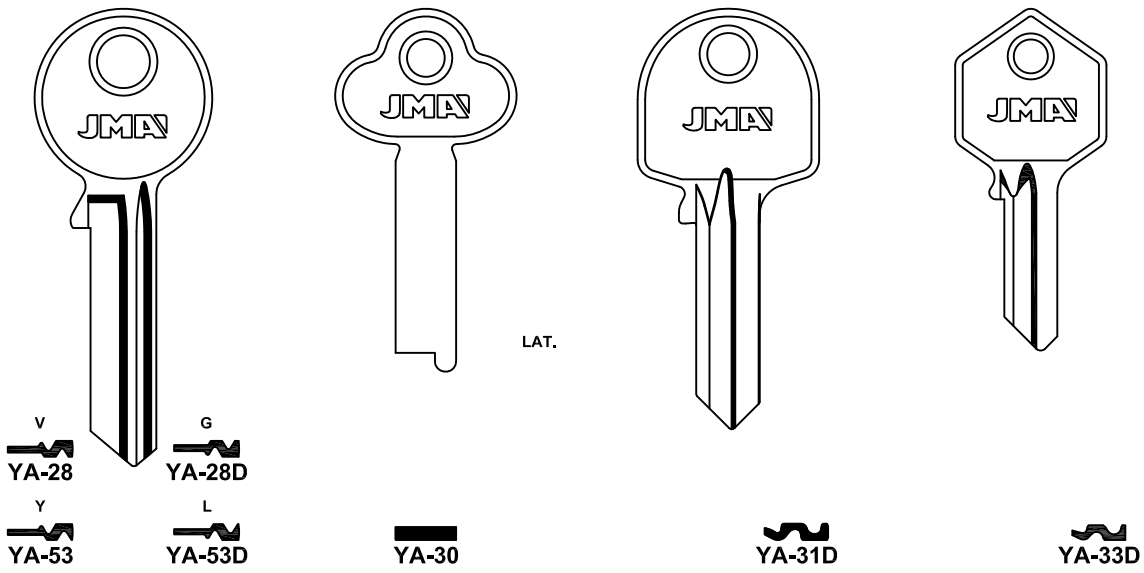

**YALE**

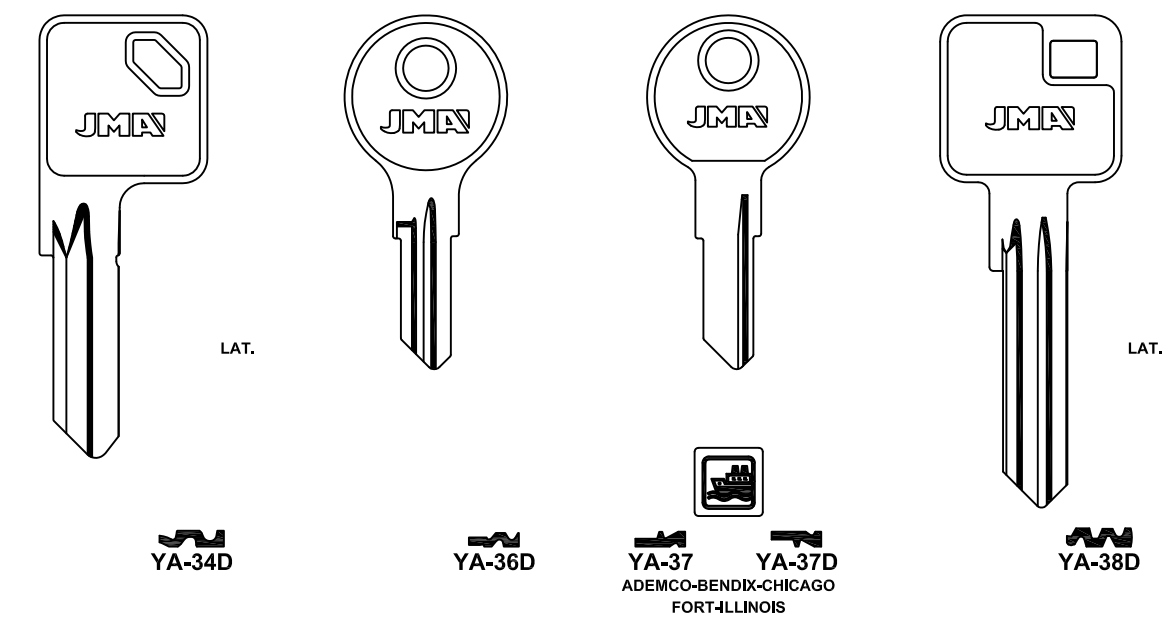

**YALE**

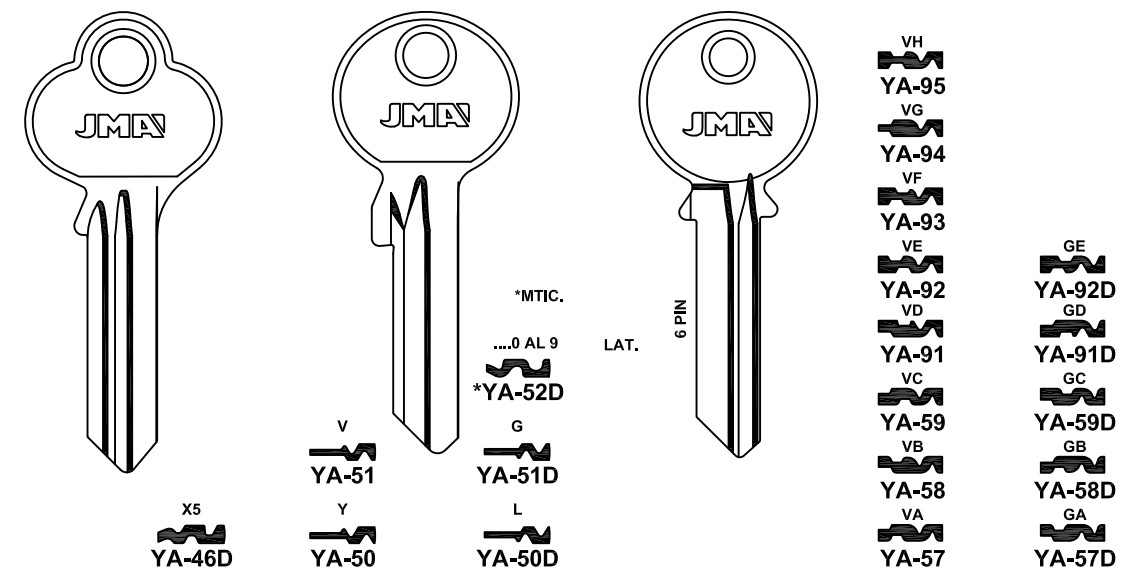

# YALE

PARA-FOR:

YALE  
(D-GB-USA)

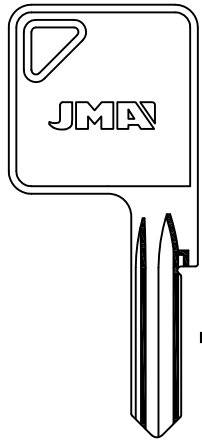

YA-72

DRAPER

LAT.

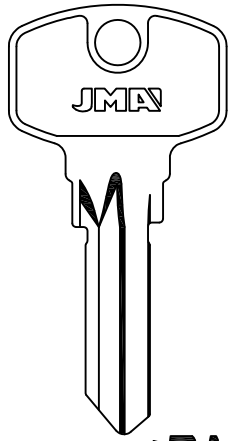

YA-79D

YA-272D

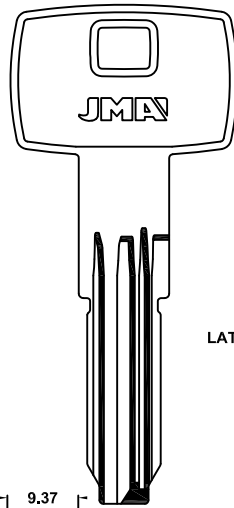

YA-81

LAT.

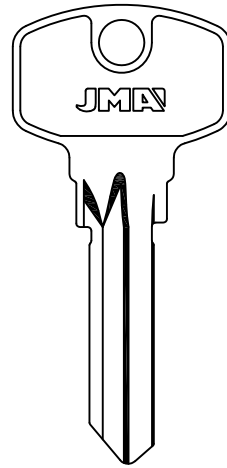

YA-85D

# YALE

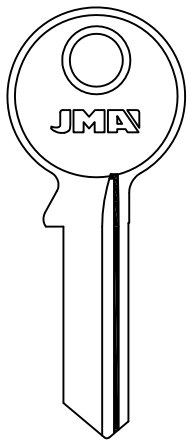

YA-88

ASSA ABLOY

RSA

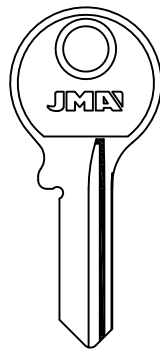

YA-89

ASSA ABLOY

RSA

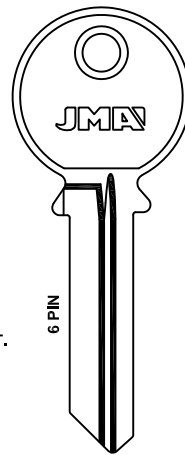

LAT.

6 PIN

LG  
YA-103D

LF  
YA-102D

LE  
YA-101D

LD  
YA-100D

LC  
YA-99D

LB  
YA-98D

LA  
YA-97D

# YALE

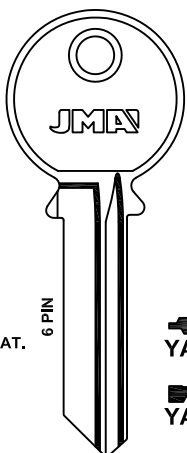

LAT.

6 PIN

YG  
YA-113

YF  
YA-112

YE  
YA-111

YB  
YA-108

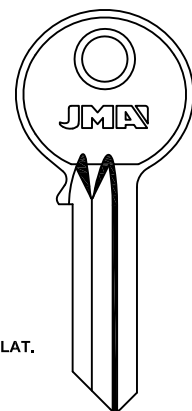

LAT.

YA-142D

BKS

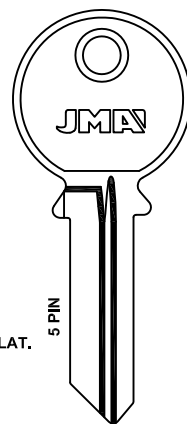

LAT.

5 PIN

GA  
YA-186D

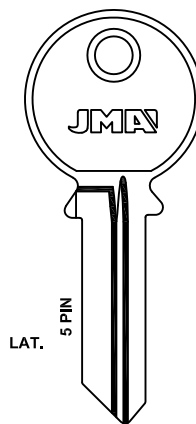

LAT.

5 PIN

LG  
YA-212D

LE  
YA-210D

LD  
YA-209D

LC  
YA-208D

LA  
YA-206D



**PARA-FOR:**

YALE  
(D-GB-USA)  
YARDENI (IL)  
YETI (RC)

**YALE**

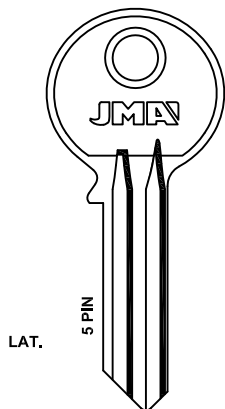

LAT.

- VF  
YA-221
- VE  
YA-220
- VD  
YA-219
- VB  
YA-217
- VA  
YA-216

BKS

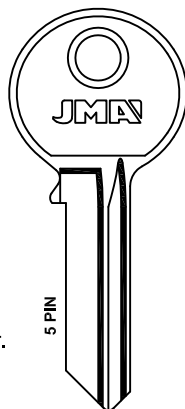

LAT.

- YH  
YA-232
- YE  
YA-229
- YD  
YA-228
- YC  
YA-227
- YB  
YA-226
- YA  
YA-225

BKS

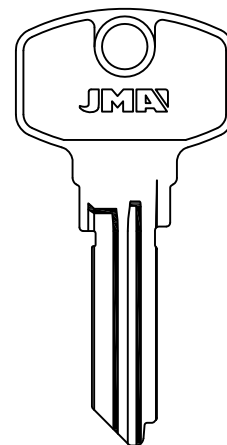

- KTM  
YA-273D

**YARDENI**

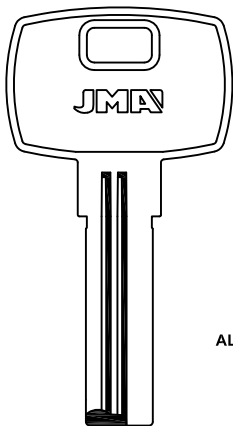

ALP.

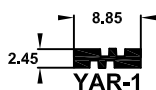

YAR-1

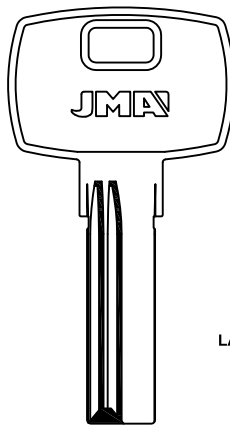

LAT.



YAR-2

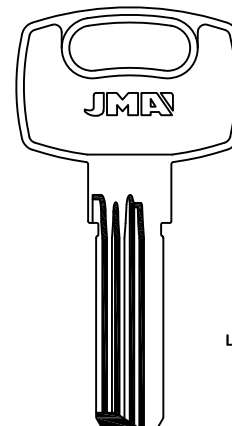

LAT.



YAR-3

**YETI**

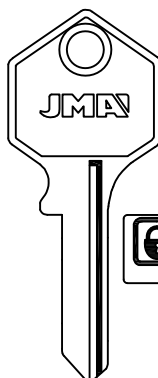

- AKIRA
- ASIA
- BELL
- DEHA
- FOUR CIRCLE
- HAIDE
- HEMY
- HERMES
- HEAD
- LOTUS
- RAM
- ROYAL
- SANCHUN
- SWAN
- VELO
- VISO
- WINFIELD
- SEZAN



YET-1



YET-1D

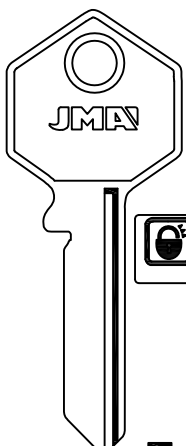

- AKIRA
- ASIA
- BELL
- DEHA
- FOUR CIRCLE
- HAIDE
- HEMY
- HERMES
- HEAD
- LOTUS
- RAM
- ROYAL
- SANCHUN
- SWAN
- VELO
- VISO
- WINFIELD
- SEZAN



YET-2



YET-2D

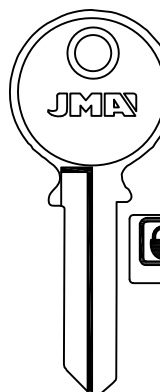

- AKIRA
- ASIA
- BELL
- DEHA
- FOUR CIRCLE
- HAIDE
- HEMY
- HERMES
- HEAD
- LOTUS
- RAM
- ROYAL
- SANCHUN
- SWAN
- VELO
- VISO
- WINFIELD
- SEZAN



YET-3D



YET-15

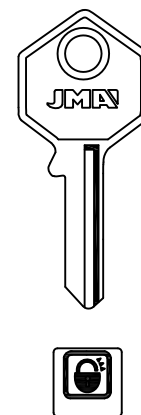

- AKIRA
- ASIA
- BELL
- DEHA
- FOUR CIRCLE
- HAIDE
- HEMY
- HERMES
- HEAD
- LOTUS
- RAM
- ROYAL
- SANCHUN
- SWAN
- VELO
- VISO
- WINFIELD
- SEZAN



YET-4



YET-4D



**YETI**



ACMA  
AMA  
BELL  
BINA  
FOUR CIRCLE  
HARR  
HENY  
HERRER  
HERR  
LOTUS  
RAM  
ROYAL  
SARGOL  
SERRA  
VILD  
VINO  
WINDFIELD  
WISAN

YET-6

YET-6D

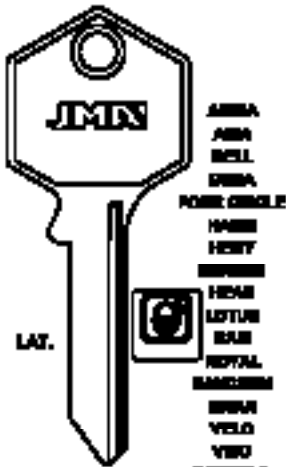

ACMA  
AMA  
BELL  
BINA  
FOUR CIRCLE  
HARR  
HENY  
HERRER  
HERR  
LOTUS  
RAM  
ROYAL  
SARGOL  
SERRA  
VILD  
VINO  
WINDFIELD  
WISAN

LAT.

YET-7

YET-7D

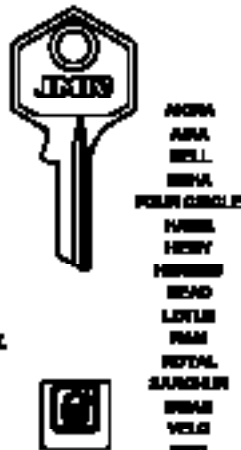

ACMA  
AMA  
BELL  
BINA  
FOUR CIRCLE  
HARR  
HENY  
HERRER  
HERR  
LOTUS  
RAM  
ROYAL  
SARGOL  
SERRA  
VILD  
VINO  
WINDFIELD  
WISAN

LAT.

YET-4

YET-4D



ACMA  
AMA  
BELL  
BINA  
FOUR CIRCLE  
HARR  
HENY  
HERRER  
HERR  
LOTUS  
RAM  
ROYAL  
SARGOL  
SERRA  
VILD  
VINO  
WINDFIELD  
WISAN

LAT.

YET-13

YET-13D

**YETI**



ACMA  
AMA  
BELL  
BINA  
FOUR CIRCLE  
HARR  
HENY  
HERRER  
HERR  
LOTUS  
RAM  
ROYAL  
SARGOL  
SERRA  
VILD  
VINO  
WINDFIELD  
WISAN

YET-10

YET-10D



ACMA  
AMA  
BELL  
BINA  
FOUR CIRCLE  
HARR  
HENY  
HERRER  
HERR  
LOTUS  
RAM  
ROYAL  
SARGOL  
SERRA  
VILD  
VINO  
WINDFIELD  
WISAN

LAT.

YET-11

YET-11D



ACMA  
AMA  
BELL  
BINA  
FOUR CIRCLE  
HARR  
HENY  
HERRER  
HERR  
LOTUS  
RAM  
ROYAL  
SARGOL  
SERRA  
VILD  
VINO  
WINDFIELD  
WISAN



YET-12



YET-17D

LOW COPY-17-17D-17-17D

**YUN HUAN**



YUH-10



YUH-10D

**YWS**



YW-1P

AMUS

**ZADI**

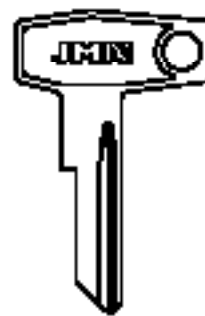

ZA-1

AMUS

**PARA-FOR:**

- YETI (RC)
- YUN HUAN (PRC)
- YMS (TW)
- ZADI (I)



**PARA-FOR:**

ZADI (I)

ZENI (GB)

**ZADI**

**ZENI**

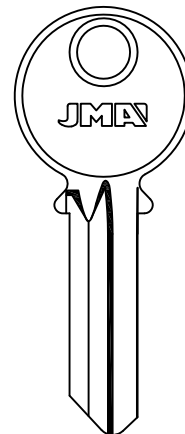
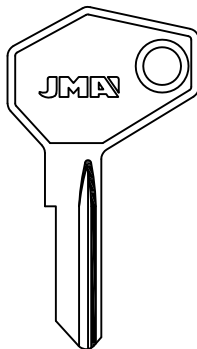
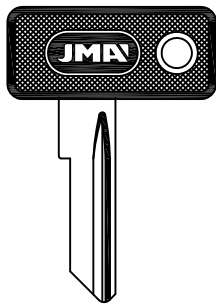

....1-1625  
....5001-6278  
E...1-710

....1-1625  
....5001-6278  
E...1-710



**ZA-1.P**

BRETER



**ZA-12**

BRETER



**ZEN-1D**



# **LLAVES PARA VEHÍCULOS**

*IBILGAILUENTZAKO GILTZAK*

*KEYS FOR VEHICLES*

*CLES POUR VEHICULES*

*FAHRZAUGESCHLÜSSEL*



**THE KEY TO EXCELLENCE**  
*GLOBALLY UNLOCKING MILLIONS OF DOORS DAILY*

**PARA-FOR:**

ABSA (E)

ABUS (D)

**ABSA**

6  
AB-1I

5  
AB-1D

7  
AB-2I

8  
AB-2D

M.LUNA

13  
AB-4D

15  
AB-7I

PROAUTO

14  
AB-5I

13  
AB-5D

FROSER

15  
AB-6I

PROAUTO

14  
AB-8I

ARREGUI

13  
AB-6D

13  
AB-8D

ARFE-FROSER-KEYA

**ABSA**

15  
AB-10I

8  
SIM-1200

**ABUS**

Z71....1-1043  
Z72....1-1043

ABU-18.P

ABU-18D.P

BUFFO

Z71....1-1043  
Z72....1-1043

ABU-19D

BUFFO

**ABUS**

Z71....1-1043  
Z72....1-1043

ABU-19.P

ABU-19D.P

BUFFO

X61...  
X62...

1-331

V61...  
V62...

ABU-35.P

ABU-36.P

BUFFO

U72

ABU-64.P











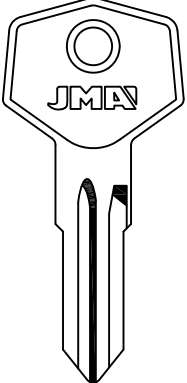

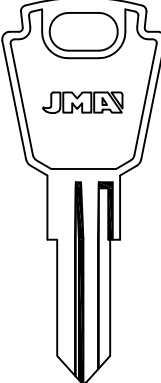
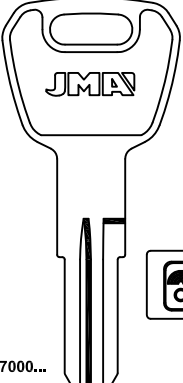

W71

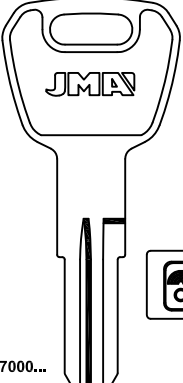
ABU-65.P

ABU-72.P



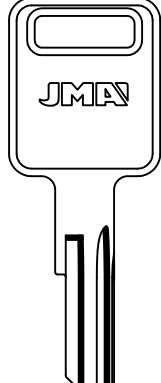







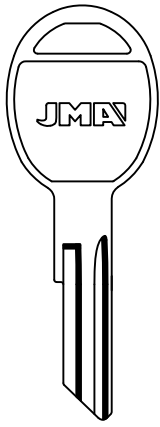

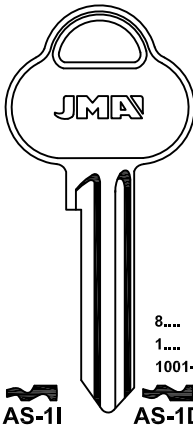



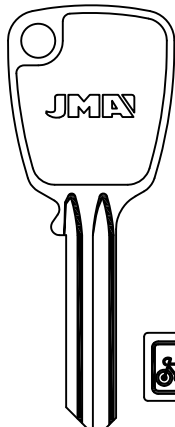



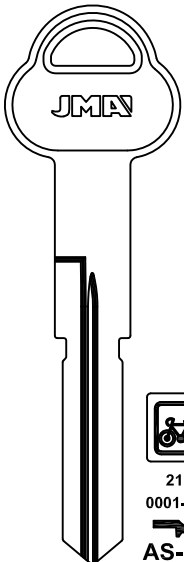



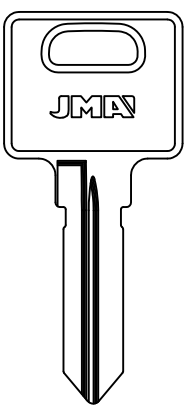

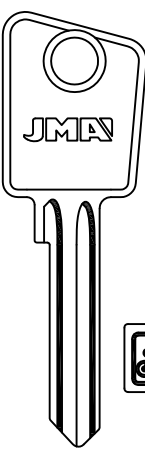

| AKS   | ALPHA  |   | AMERICAN MO.  |
|---|--|---|---|
|  <p>KA<br/>001-100</p>  <p><b>AKS-1</b><br/>VOLVO</p> |   <p>7000...</p>  <p><b>ALP-2</b></p>  <p><b>ALP-2D</b></p> <p>JD-LINCE-MONACOR<br/>SANY-VISONIC</p> <p>S...301-600</p>  <p><b>ALP-1I</b></p>  <p><b>ALP-1D</b></p> <p>FEB</p> |   <p>7000...</p>  <p><b>ALP-2</b></p>  <p><b>ALP-2D</b></p> <p>JD-LINCE-MONACOR<br/>SANY-VISONIC</p> <p>S...301-600</p>  <p><b>ALP-6</b></p>  <p><b>ALP-6D</b></p> <p>FEB</p> |  <p>LAT.</p>  <p><b>AMM-1</b></p> |

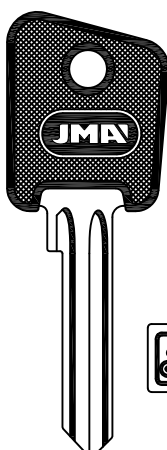
**PARA-FOR:**

- AKS (D)
- ALPHA (J)
- AMERICAN MOTORS (USA)
- ASSA (S)
- AXA (S)

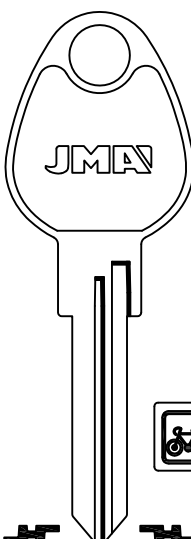
| AMERICAN MO.   | ASSA  |   |   |
|--|---|---|---|
|  <p>LAT.</p>  <p><b>AMM-2</b></p> |  <p>8...<br/>1...<br/>1001-3300</p>  <p><b>AS-1I</b></p>  <p><b>AS-1D</b></p> <p>7...<br/>6...<br/>1001-3300</p>  <p><b>AS-24</b></p>  <p><b>AS-24D</b></p> <p>SAAB-VOLVO</p> |   <p>....<br/>700-7999</p>  <p><b>AS-2I</b></p> <p>....<br/>6000-8999</p>  <p><b>AS-2D</b></p> |   <p>21...<br/>0001-9999</p>  <p><b>AS-17D</b></p> <p>BICICLETTA CYCLES</p> |

| ASSA  |  | AXA  |
|---|--|--|
|  <p>21...<br/>0001-9999</p>  <p><b>AS-19D</b></p> |   <p>7000-7999<br/>A...<br/>7000-7999</p>  <p><b>AS-21</b></p> <p>8000-9999<br/>A...<br/>9000-9999</p>  <p><b>AS-21D</b></p> |   <p>7000-7999<br/>A...<br/>7000-7999</p>  <p><b>AS-21.P</b></p> <p>8000-9999<br/>A...<br/>9000-9999</p>  <p><b>AS-21D.P</b></p> |
|   |  |   <p><b>AX-1</b></p>  <p><b>AX-1D</b></p>   |



**PARA-FOR:**

AXA (S)

AZU (E)

BASCO (USA)

BLAU (D)

**AXA**

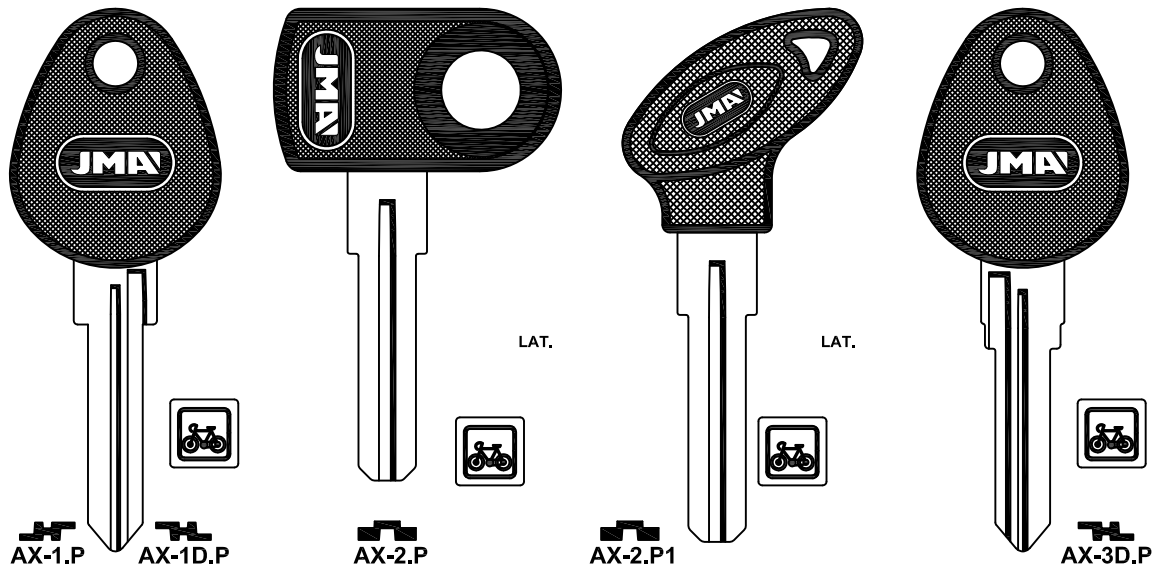

**AXA      AZU      BASCO**

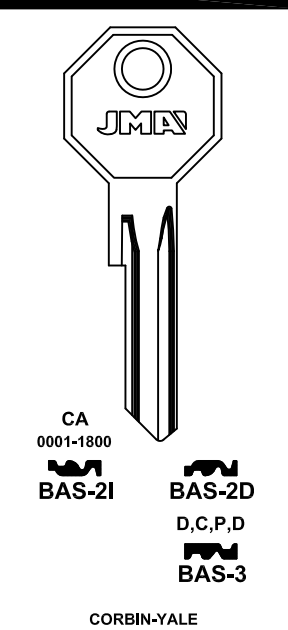
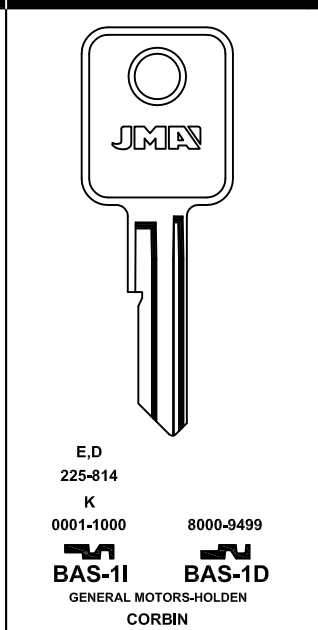
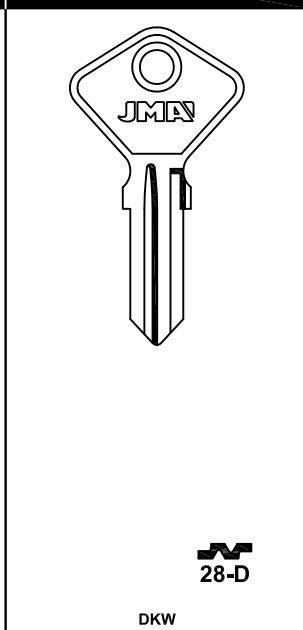
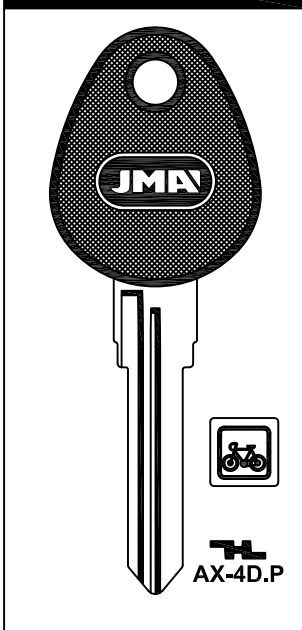

**BASCO**

**BLAU**

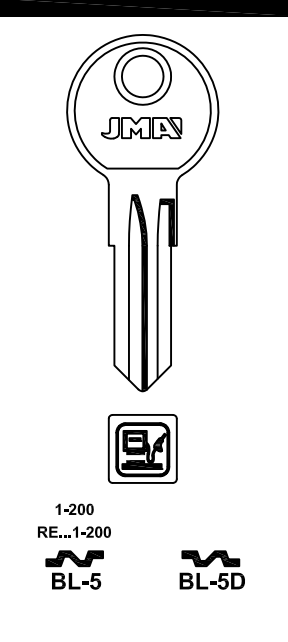
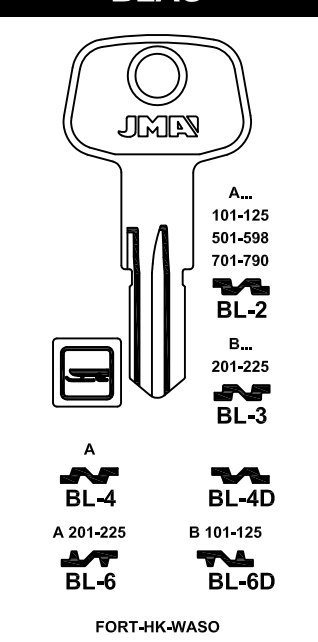
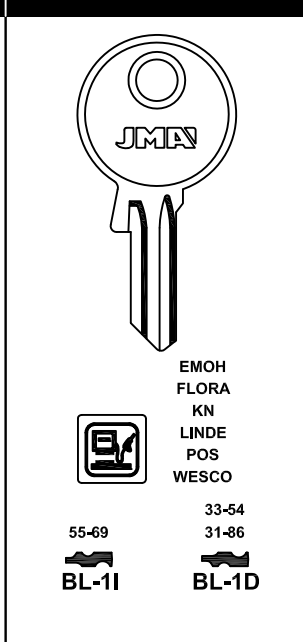
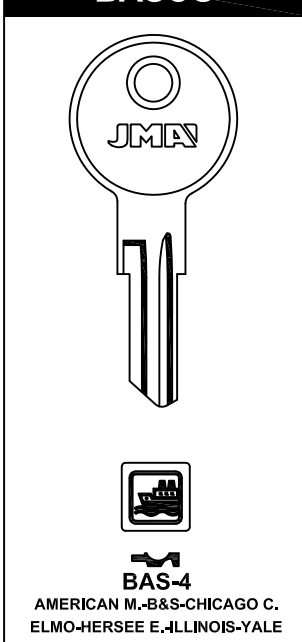

**BOMBARDIER**

**BOMORO**

**BOSCH**

**PARA-FOR:**

- BOMBARDIER (USA)
- BOMORO (D)
- BOSCH (D)
- BRABANTIA (E)
- B.&S. (USA)

LAT.

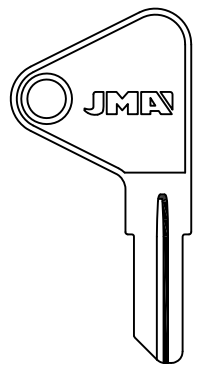

**BOB-1D**

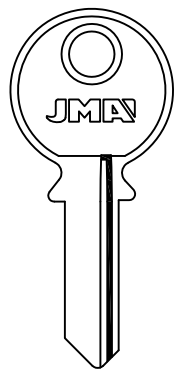

**BOM-2 BOM-2D**

LAPORTE-PRESTA

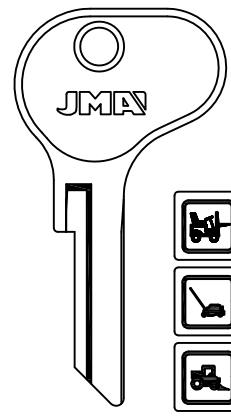

E, M, N, U, H, K  
001-100  
HG, N 140-189  
HG 040-100

**BH-1**

NEIMAN

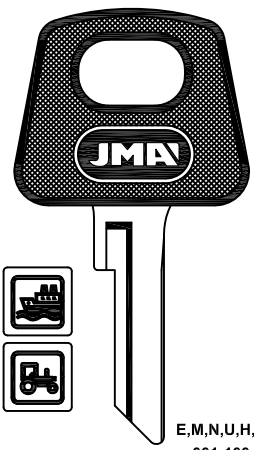

E, M, N, U, H, K  
001-100  
HG, N 140-189  
HG 040-100

**BH-1.P**

NEIMAN

**BOSCH**

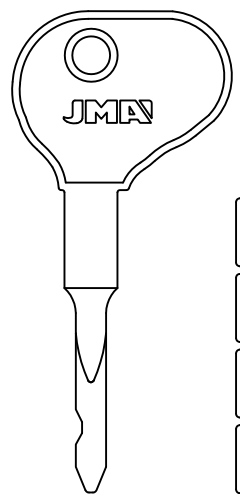

**BH-2**

FIAT IVECO-MACK M-SCANIA

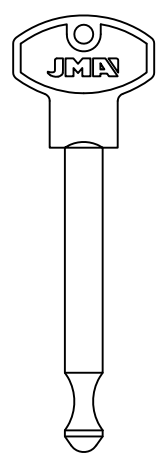

**BH-3**

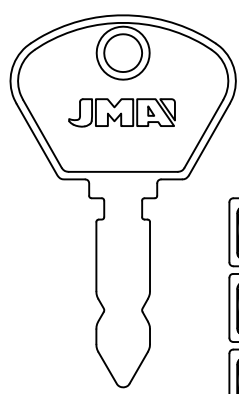

7,1 1,95  
**BH-4**

DISALCAR-OM IVECO-SULKY  
KOLB-POLAR

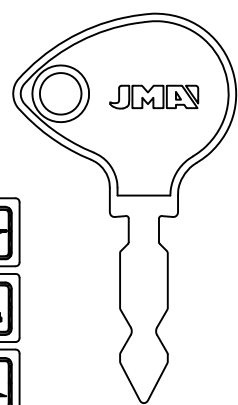

6,3 2  
**BH-5**

**BOSCH**

**BRABANTIA**

**B & S**

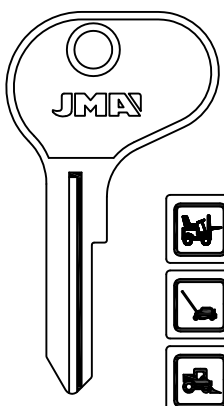

**BH-6**

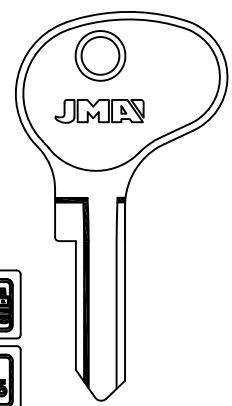

MS-S  
1-50  
**BH-8**

KOLB-LAPORTE

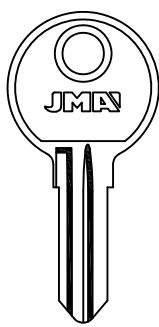

**BRA-2**

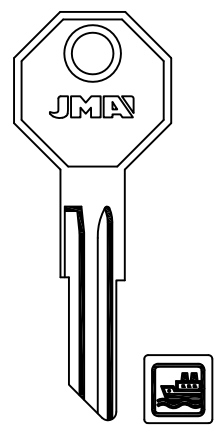

N  
1501-1700  
NA  
001-200

**BS-11**

AMERICAN MOTORS-MACK  
DEXTER



**PARA-FOR:**

- B.&S. (USA)
- BURG (D)
- CAMA (I)
- CASELLAS (E)
- CATERPILLAR (USA)
- CEM (GB)

**BRIGGS & STRATTON**

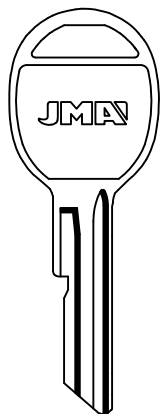

E...225-814  
L...1-1000  
**BS-2**

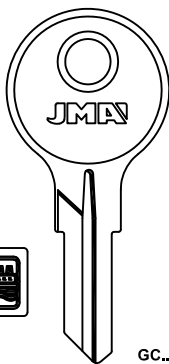

A...250-1500  
AP...250-1500  
B...250-1500  
C...1251-1700  
CB...250-1500  
DC-EP...250-699  
P...250-1500  
**BS-6**

LAT.

- GC... 101-150
- HC... 0-499
- BS-4D**

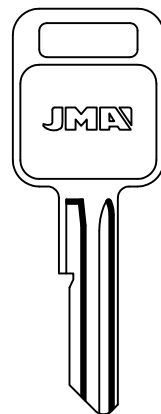

D 225-814  
K 01-1000  
**BS-5**

LAT.

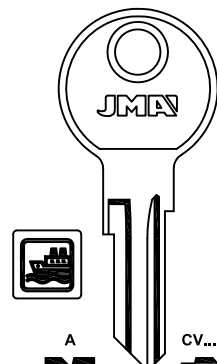

A  
**BS-7**  
D  
**BS-8**  
E  
**BS-9**

\* LAT.

CV...1-1500  
\* **BS-7D**  
C  
**BS-8D**  
F  
**BS-9D**

**BURG**

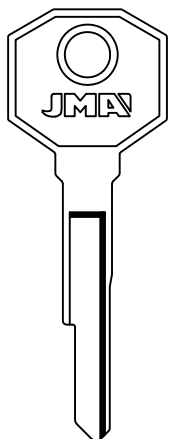

**BUR-6**

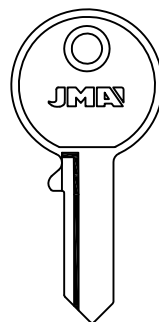

**BUR-30D**

MOFA

**CAMA**

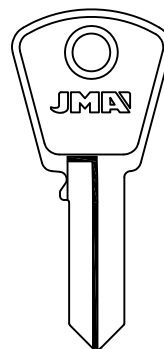

**CAM-1D**

FIST

**CASELLAS**

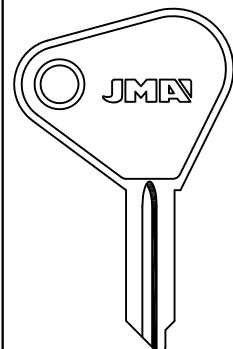

**CAS-1D**

OSSA

**CATERPILLAR**

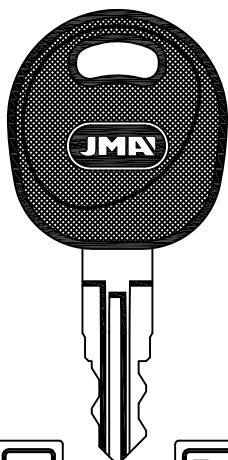

**CAT-1.P**

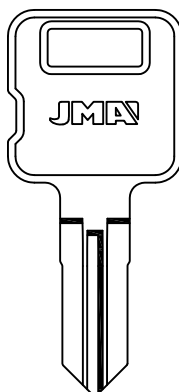

**CAT-2**

LAT.

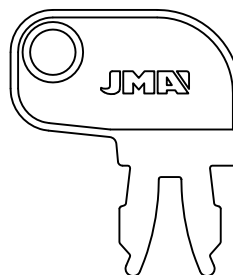

**CAT-3**

LAT.

**CEM**

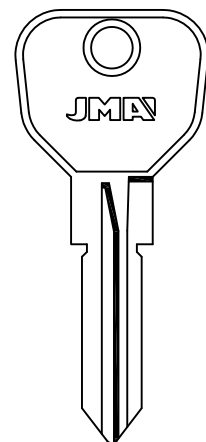

BP  
**CEM-BP**



| CEM  | CESSNA   | CHRYSLER                 |                          |
|--|--|--------------------------|--------------------------|
|  |  |                          |                          |
| JC<br>001-852<br><br><b>CEM-JC</b><br>DAIMLER-JAGUAR-ROVER-VOLVO | AK<br>0001-1000<br><br>500-999<br><br><b>CN-1D</b> | <br><b>CHR-1</b><br>YALE | <br><b>CHR-2</b><br>ROSS |

**PARA-FOR:**

- CEM (GB)
- CESSNA (USA)
- CHRYSLER (USA)

| CHRYSLER   |   |   |  |
|--|---|---|--|
|  |   |   |  |
| .....<br>.....A/Z<br>B-C-D-E<br>1/9.....A/Z<br>1/9.....A/Z<br>.....A/Z<br>B-D-E-G-H-J<br>.1/9.....A/Z<br>.1/9.....A/Z<br>E-M-N-P-R<br><br><b>CHR-3</b><br>CLAUSOR-NEIMAN | A.MOTORS<br>CITROEN<br>MAZDA<br>PEUGEOT<br>RENAULT<br>TALBOT<br>DAF<br>NISSAN<br>PEGASO<br>.....<br>.....A/Z<br>B-C-D-E<br>1/9.....A/Z<br>1/9.....A/Z<br>.....A/Z<br>B-D-E-G-H-J<br>.1/9.....A/Z<br>.1/9.....A/Z<br>E-M-N-P-R<br><br><b>CHR-3.P</b><br>CLAUSOR-NEIMAN | <br><b>CHR-5</b><br>NISSAN-PEGASO<br>ROSS | Z<br>001-224<br><br><b>CHR-6</b><br>W<br>001-224<br><br><b>CHR-6D</b><br>KIFERM-PJ |

| CHRYSLER  |  |   |   |
|---|--|---|---|
|   |  |   |   |
| CJ<br>001-500<br>DP<br>0001-1400<br>EP<br>0001-3000<br><br><b>CHR-7</b><br>CHRYSLER<br>YALE | DP<br>0001-1400<br>EP<br>0001-3000<br><br><b>CHR-8</b><br>CHRYSLER<br>YALE | CJ<br>001-500<br>DP<br>0001-1400<br>EP<br>0001-3000<br><br><b>CHR-7.P</b><br>CHRYSLER<br>YALE | DP<br>0001-1400<br>EP<br>0001-3000<br><br><b>CHR-8.P</b><br>CHRYSLER<br>YALE            |
|   |  | F.... G....<br>0000-1394<br><br><b>CHR-9</b><br>AMERICAN MOTORS-CHRYSLER-JEEP<br>YALE         | F.... G....<br>0000-1394<br><br><b>CHR-9.P</b><br>AMERICAN MOTORS-CHRYSLER-JEEP<br>YALE |



**PARA-FOR:**

CHRYSLER  
(USA)

CLAUSOR (E)

**CHRYSLER**

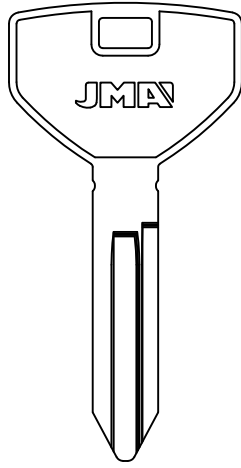

J....  
0001-3580



**CHR-10**  
AMERICAN MOTORS-CHRYSLER-JEEP  
YALE

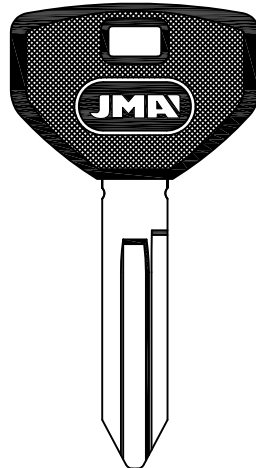

J....  
0001-3580



**CHR-10.P**  
AMERICAN MOTORS-CHRYSLER-JEEP  
YALE

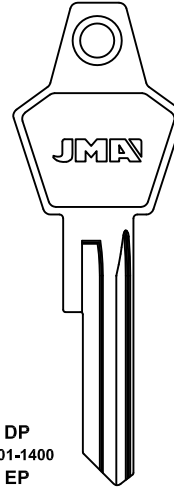

DP  
0001-1400  
EP  
0001-3000



**CHR-11**  
CHRYSLER  
YALE

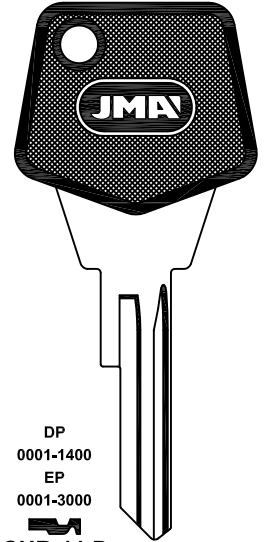

DP  
0001-1400  
EP  
0001-3000



**CHR-11.P**  
CHRYSLER  
YALE

**CHRYSLER**

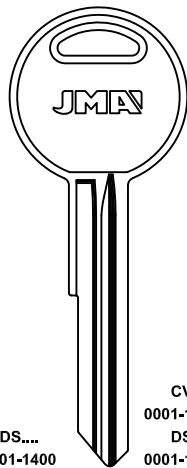

DS....  
0001-1400  
ES....  
0001-3000



**CHR-12**  
CHRYSLER

BRIGGS & STRATTON

CV  
0001-1500  
DS  
0001-1500  
ES  
0001-1500



**CHR-13D**  
CHRYSLER

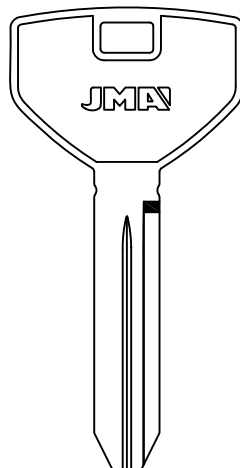

L.... 1-3580



**CHR-14**  
CHRYSLER

BRIGGS & STRATTON-YALE

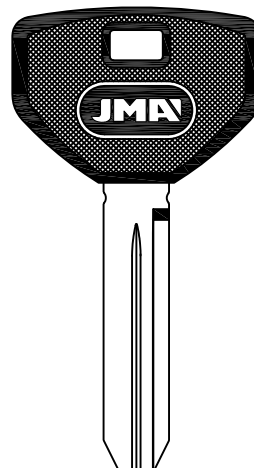

L.... 1-3580



**CHR-14.P**  
CHRYSLER

BRIGGS & STRATTON-YALE

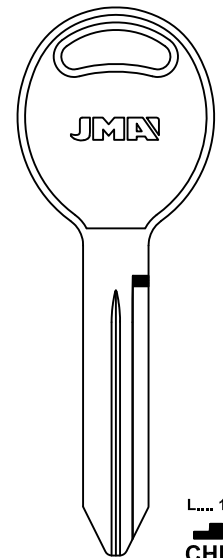

L.... 1-3580



**CHR-15**  
CHRYSLER

BRIGGS & STRATTON-YALE

**CHRYSLER**

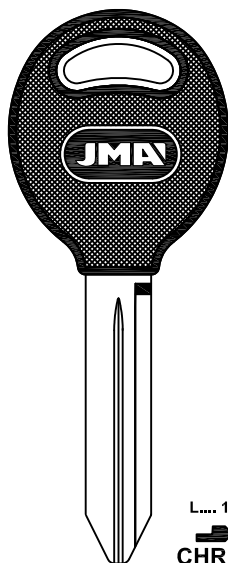

L.... 1-3580



**CHR-15.P**  
CHRYSLER

BRIGGS & STRATTON-YALE

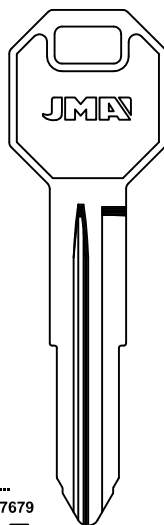

E....  
5001-7679



**CHR-17**  
CHRYSLER

**CLAUSOR**

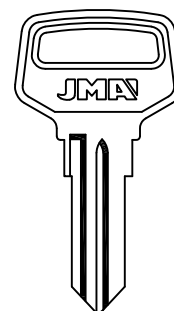

ALU.



**CL-11**

BRABANTIA

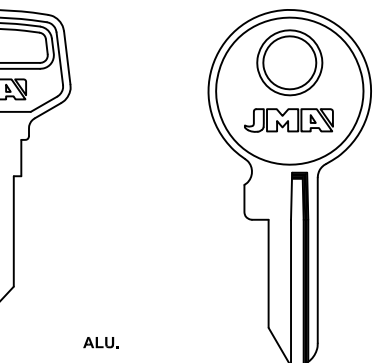

**CL-21**

EBRO-CAGIVA-LINCE-MAICO  
MONTESA-OSSA-PIAGGIO VESPA

**CL-2D**



## CLAUSOR

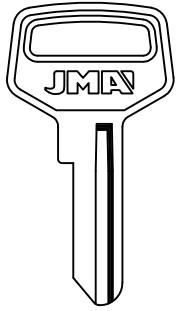

**CL-3I**

EBRO-CAGIVA-LINCE-MAICO  
MONTESSA-OSSA-PIAGGIO VESPA

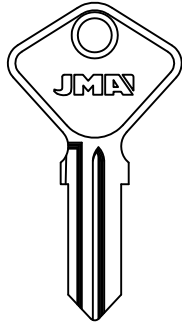

**CL-4I**

JEEP

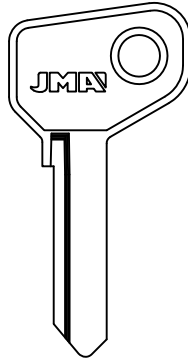

**CL-5D**

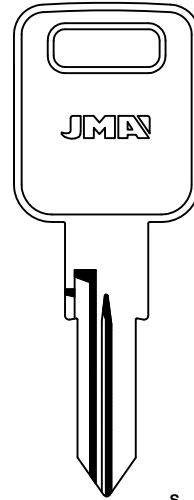

**CL-6**

SEAT

## PARA-FOR:

CLAUSOR (E)

CLICK (RA)

CLUM (USA)

COBRA (I)

## CLAUSOR

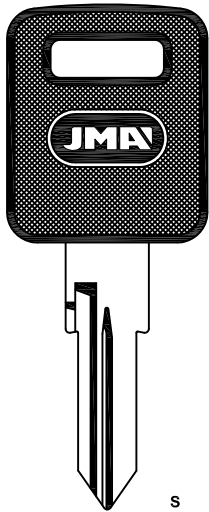

**CL-6.P**

SEAT

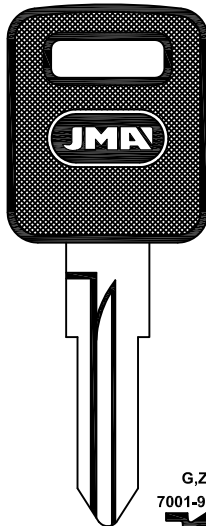

G,Z  
7001-9956  
**CL-7.P**

SEAT  
GIOBERT

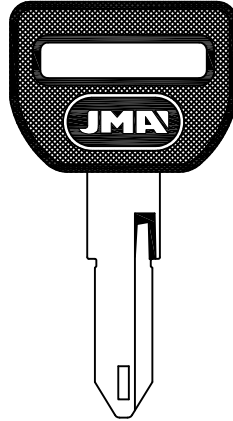

M,N,P,R,S  
1/9...A/Z  
**CL-8.P**

CITROEN

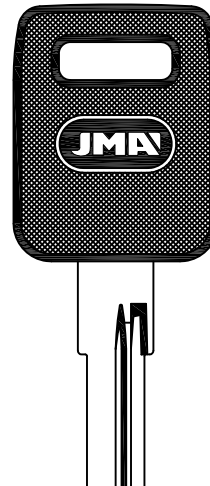

HV  
**CL-9.P**

SEAT

## CLAUSOR

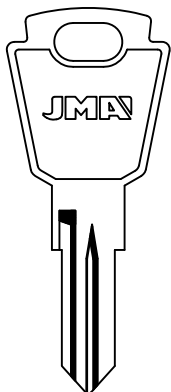

**SIM-900**

## CLICK

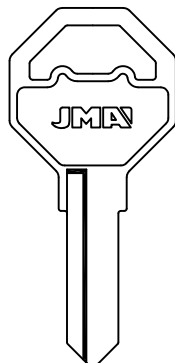

**CLI-1D**

## CLUM

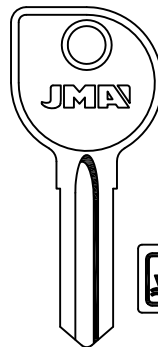

**CLU-1I**

**CLU-1D**

**CLU-2**

**CLU-3**

\* **CLU-4**

\* **CLU-5**

MERCURY

## COBRA

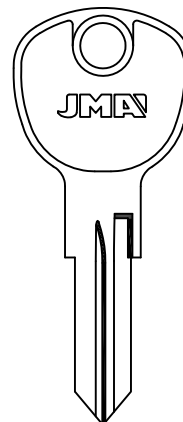

**COB-1**

**JMA**<sup>®</sup>

Copyright by Alejandro Altuna S.A. 2014



ATENCIÓN: Concerniente a las marcas y denominaciones comerciales ver nota en índice.  
ATTENTION: Concerning the marks and commercial denominations see note in index.  
ATTENTION: Concernant les marques et dénominations commerciales voir la note dans l'index.  
ACHTUNG: Beziehen auf die marke und handelsname sehen sie die notiz im index.











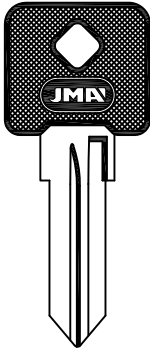
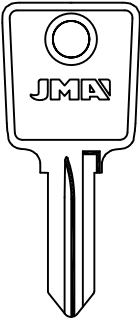
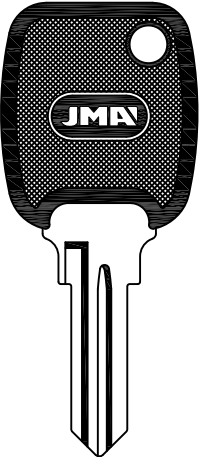
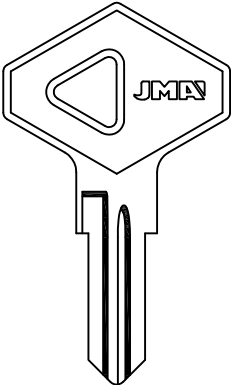





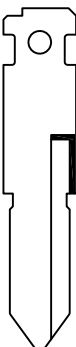
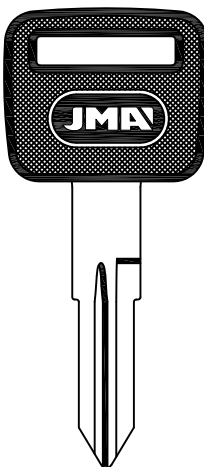

**PARA-FOR:**

COBRA (I)

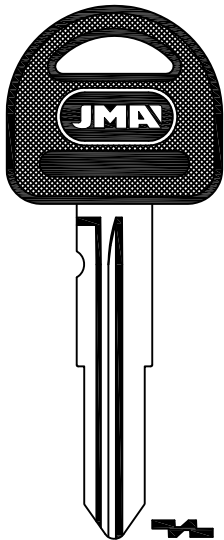
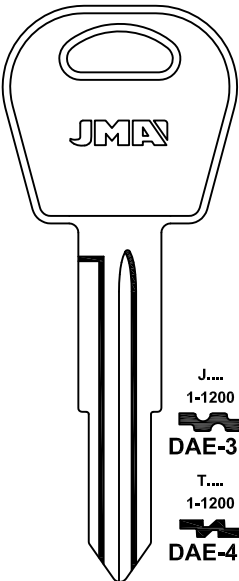
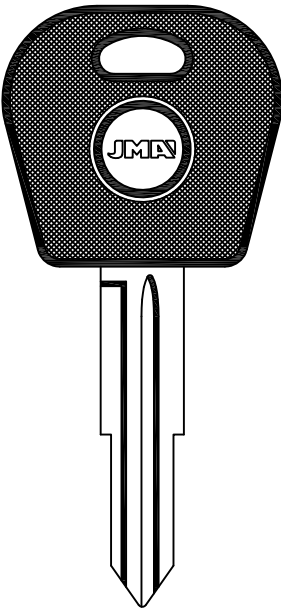
DACIA (R)

DAELIM (K)

DAEWOO (K)

| COBRA   |  | DACIA  |   |
|---|--|--|---|
|    |   |    |                                  |
|   |    |   |                                  |
| COB-1.P   | COB-2  | DAC-1D.P   | DAC-2D  |
| DACIA   |  |  | DAELIM  |
|   |    |    |                                  |
|    |    |  |                                |
| DAC-3DC1  | DAC-4DC1   | DAC-5C1  | DAL-1.P   |
| HUF   |  |  | DAEWOO  |
| DAEWOO  |  |  |   |
|    |   |    |   |
|    | J...<br>1-1200<br><br>DAE-3D<br>T...<br>1-1200<br><br>DAE-4D | J...<br>1-1200<br><br>DAE-3D.P1<br>T...<br>1-1200<br><br>DAE-4D.P1 | V...<br>1-1200<br><br>DAE-4.P1 |
| DAEWOO  |  |  |   |





**DAEWOO**

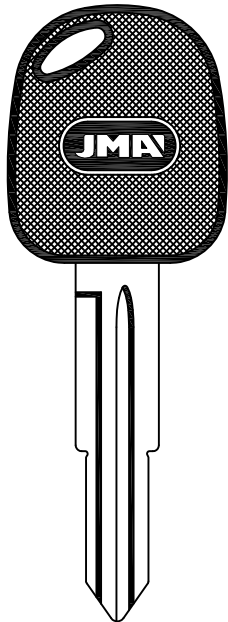

DAE-3.P2  
 J...  
 1-1200  
 DAE-3D.P2

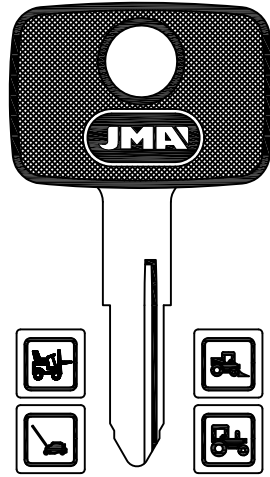

DAE-5.P

**DAIHATSU**

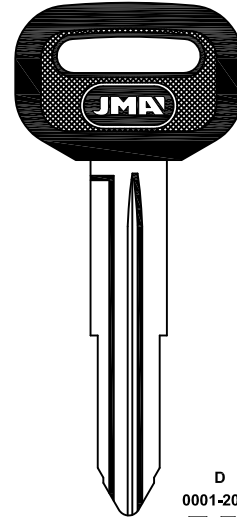

D  
 0001-2000  
 DAI-1.P  
 BERTONE-DAIHATSU

**PARA-FOR:**

- DAEWOO (K)
- DAIHATSU (J)
- DARMIX (F)
- DAV (F)
- DOBLE G (ARG)
- DOBLINA (D)
- DOM (D)

**DAIHATSU**

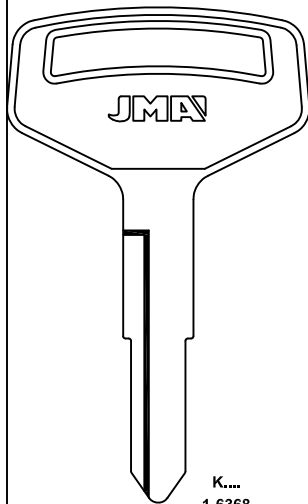

K...  
 1-6368  
 DAI-2D

**DARMIX**

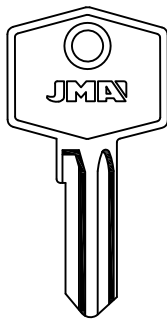

DAR-1

**DAV**

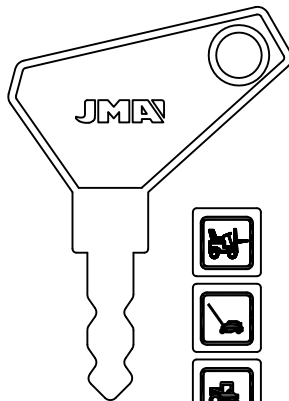

6,1 1,95  
 DAV-1  
 DAF-MACK-RENAULT SAVIEM

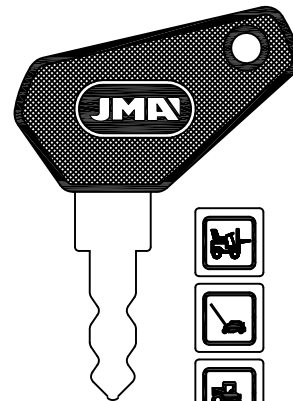

6,1 1,95  
 DAV-1.P  
 DAF-MACK-RENAULT SAVIEM

**DOBLE G**

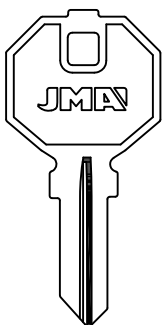

GG-1D

**DOBLINA**

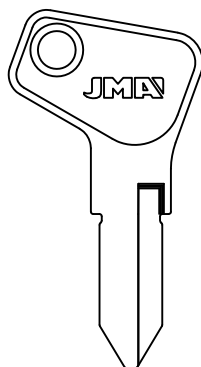

DOB-1 DOB-1D  
 .....6  
 10000-44031  
 DOB-2 DOB-2D  
 TRABANT-WARTBURG

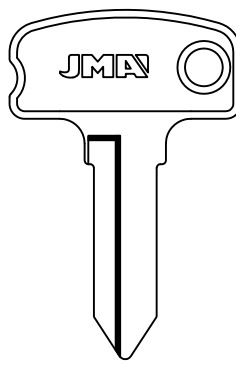

10000-44031  
 ....26 ....25  
 DOB-3 DOB-3D  
 TRABANT-WARTBURG

**DOM**

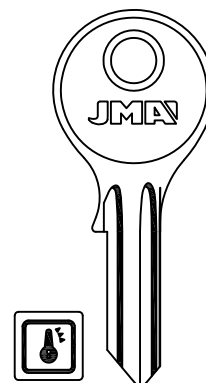

EV...1-2840  
 GS...1-1000  
 FT...1-1000  
 CQ...301-400  
 ....1-1000  
 EV...1-2840  
 DOM-9 DOM-9D  
 NOBO



**PARA-FOR:**

- DOM (D)
- DUBOIS (F)
- ECHO (I)
- EUROLOCKS (B)
- FAAB (I)
- FAB (CZ)

| DOM   |                                      | DUBOIS  |  | ECHO                                 |  |
|---|--------------------------------------|---|--|--------------------------------------|--|
|   |                                      |   |  |                                      |  |
| <br>FA-GZ<br>0001-3948<br><br><b>DOM-14D</b>              | <br><b>DOM-38D</b>                   | A...<br>1-2-3<br><br><b>DU-1</b><br>FLAMBO-YVEL | <br><b>ECH-1</b>                             |                                      |  |
| EUROLOCKS   |                                      | FAAB  |  | FAB                                  |  |
|   |                                      |   |  |                                      |  |
| <br>LAT.<br><br>7,6<br>2,9<br><b>EU-12</b><br>HOBBY-HYMER | <br>2<br>100-309<br><br><b>FAB-1</b> | <br>4...<br>100-309<br><br><b>FAB-2</b>         | 29,8 mm<br><br><b>SKO-1</b><br>SKODA         |                                      |  |
| FAB   |                                      |   |  |                                      |  |
|   |                                      |   |  |                                      |  |
| 29,8 mm<br><br><b>SKO-1.P</b><br>SKODA                    | 27,8 mm<br><br><b>SKO-2</b><br>SKODA | 4AB...1-2780<br><br><b>SKO-3I</b><br>SKODA      | 4AB...1-2780<br><br><b>SKO-3I.P</b><br>SKODA | 23,7 mm<br><br><b>SKO-4</b><br>SKODA |  |



**FAB**



4AE...  
1-2780



SKO-5.P

SKODA

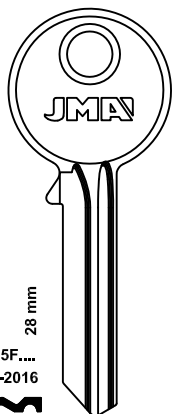

28 mm

75F...  
1-2016



SKO-6

73F...  
74F...  
1-3120



SKO-7

SKODA

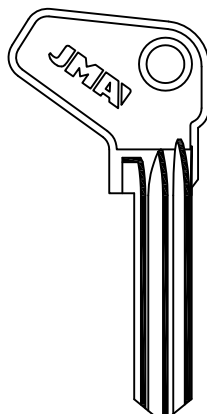

SKO-8

**FAICA**

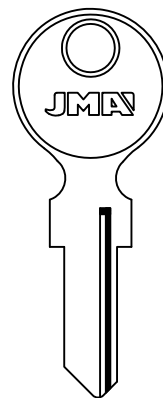

FAI-B



FAI-D



FAI-A



FAI-C

**PARA-FOR:**

FAB (CZ)

FAICA (E)

FARMA (I)

FEMSA (E)

FIAT (I)

FIST (I)

FLORA (D)

FORD (USA)

**FARMA**

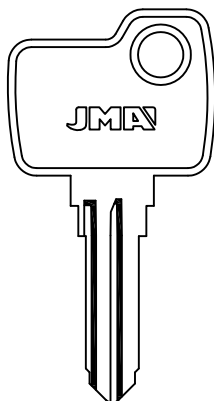

6  
100-517



FAR-1I

2  
100-517



FAR-2I

H  
100-309



FAR-3

8  
100-517



FAR-1D

4  
100-517



FAR-2D

FAR-3D



FAR-4D



FISAM

**FEMSA**

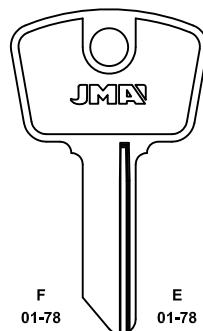

F  
01-78



FEM-1I

H  
01-78



FEM-2I



FEM-3I

E  
01-78



FEM-1D

G  
01-78



FEM-2D



FEM-3D

**FIAT**

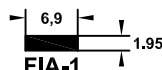
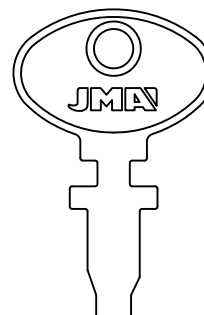

FIA-1

**FIAT**

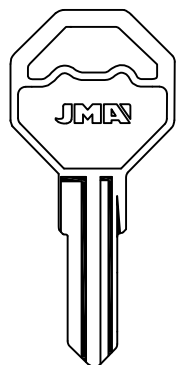

FIA-2

**FIST**

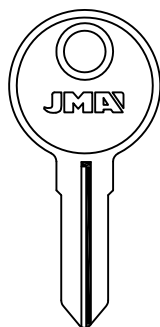

FIS-1D

**FLORA**

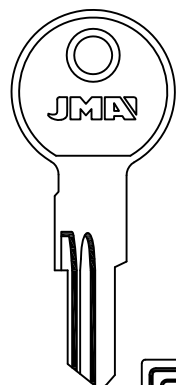

903-979  
1-9 00-80



FLO-2D

RUNO

**FORD**

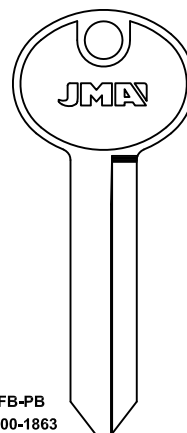

FB-PB  
0000-1863



FO-1



FO-3

FORD (USA)



FO-3D



**PARA-FOR:**

FORD (USA)

**FORD**

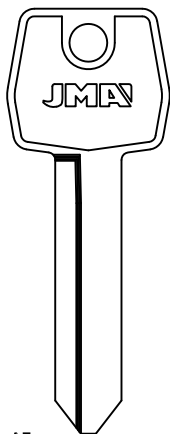

AF  
0001-2600  
FA-PA  
0000-1863



**FO-2**  
FORD (USA)-MASERATI



**FO-3.P**  
FORD (USA)

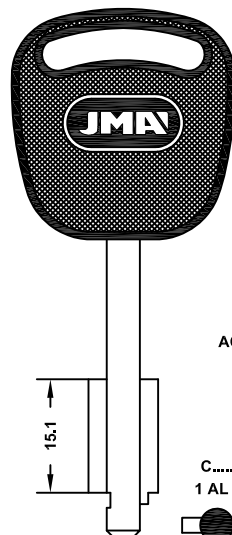

15.1

ACE.

C.....  
1 AL 5



**FO-4.P**

FORD  
KOLB

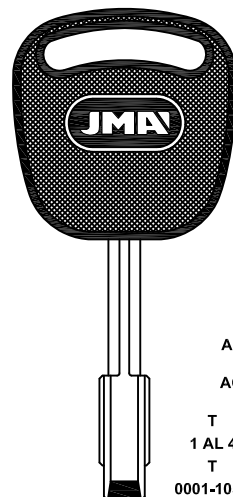

ALP.  
ACE.

T  
1 AL 4  
T  
0001-1050



**FO-6.P**

FORD  
HUF

**FORD**

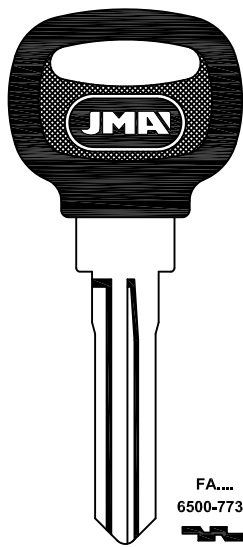

FA....  
6500-7733



**FO-7.P**

FORD

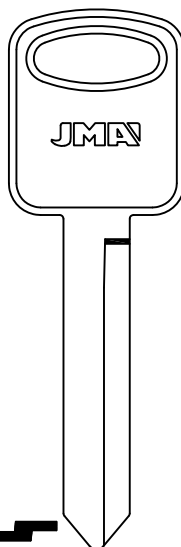

A  
101-291  
501-579  
B  
101-332  
501-602  
C  
101-344  
501-624  
D  
101-327  
501-602  
E  
101-296  
501-579



**FO-8**

FORD

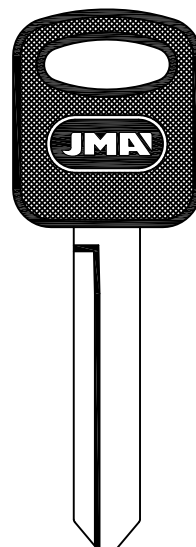

A  
101-291  
501-579  
B  
101-332  
501-602  
C  
101-344  
501-624  
D  
101-327  
501-602  
E  
101-296  
501-579



**FO-8D.P**

FORD

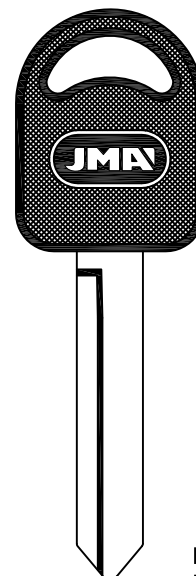

A  
101-291  
501-579  
B  
101-332  
501-602  
C  
101-344  
501-624  
D  
101-327  
501-602  
E  
101-296  
501-579



**FO-8D.P1**

FORD-MERCURY

**FORD**

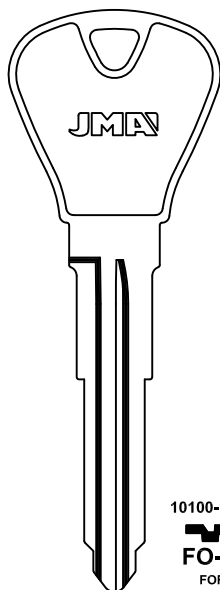

10100-12099



**FO-9D**

FORD

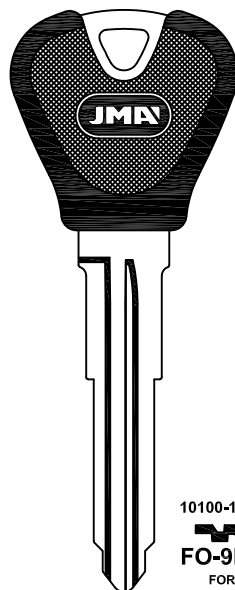

10100-12099



**FO-9D.P**

FORD

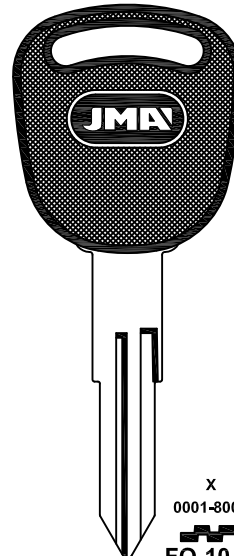

X  
0001-8000



**FO-10.P**

FORD

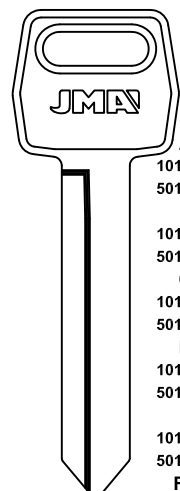

A  
101-291  
501-579  
B  
101-332  
501-602  
C  
101-344  
501-624  
D  
101-327  
501-602  
E  
101-296  
501-579  
FA  
6500-7733



**FO-11D**

FORD



FORD

PARA-FOR:

FORD (USA)

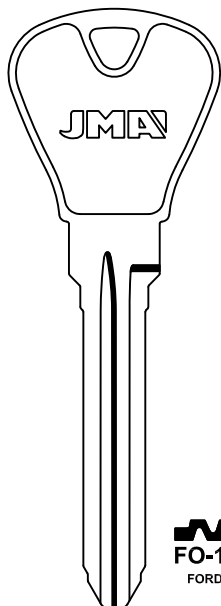

FO-12  
FORD

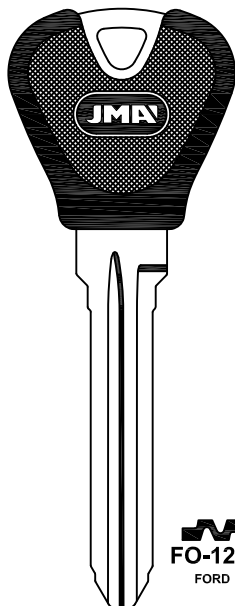

FO-12.P  
FORD

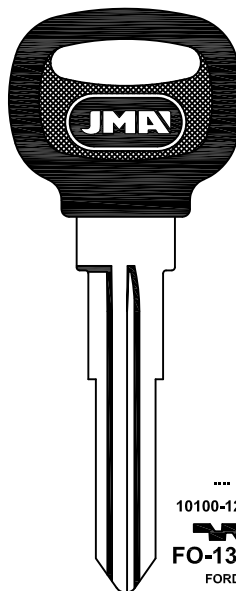

....  
10100-12099  
FO-13D.P  
FORD

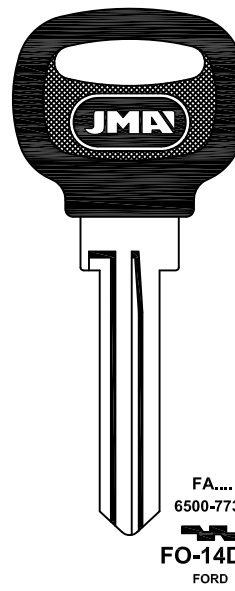

FA....  
6500-7733  
FO-14D.P  
FORD

FORD

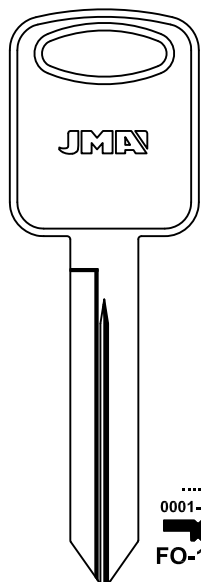

....X  
0001-1706  
FO-15D

STRATTEC

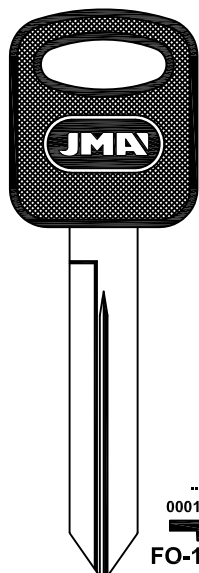

....X  
0001-1706  
FO-15D.P

STRATTEC

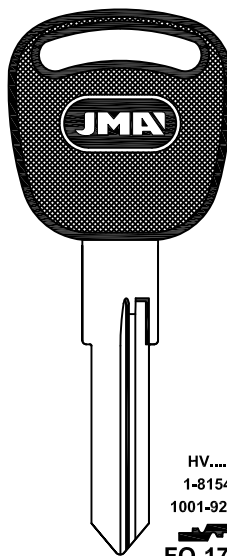

HV....  
1-8154  
1001-9282  
FO-17.P

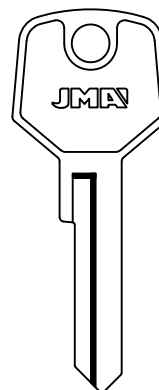

FO-18D

FORD

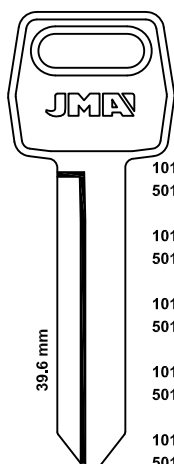

39.6 mm

- A  
101-291  
501-579
- B  
101-332  
501-602
- C  
101-344  
501-624
- D  
101-327  
501-602
- E  
101-296  
501-579
- FA  
6500-7733

FO-20D  
FORD

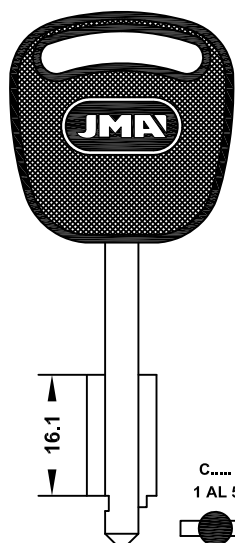

16.1

C....  
1 AL 5  
FO-22.P

FORD  
KOLB

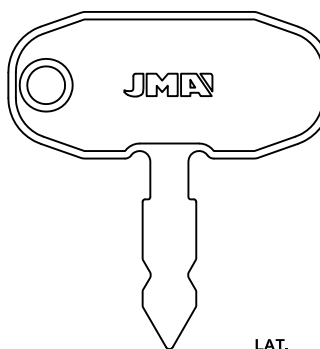

LAT.



FO-35



**PARA-FOR:**  
FORD (USA)

**FORD**

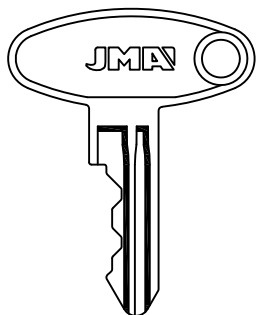

FO-36

LAT.

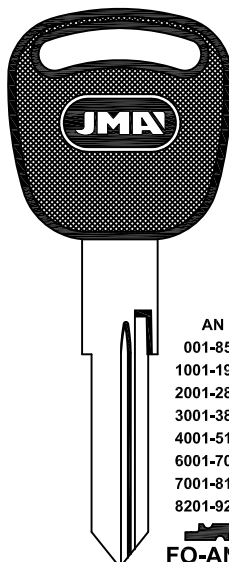

AN  
001-854  
1001-1918  
2001-2830  
3001-3890  
4001-5151  
6001-7086  
7001-8154  
8201-9282

FO-AN.P

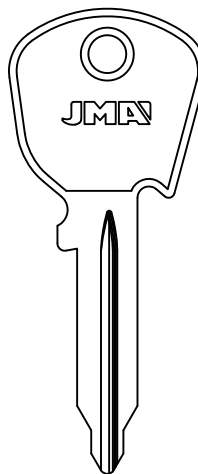

B-D-DV  
01-64

FO-D

FORD-JAGUAR-VOLKSWAGEN  
BRITAX-KOLB

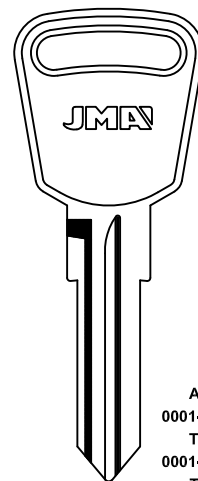

AK  
0001-1000  
TC  
0001-1000  
TX  
0001-1859

FO-E/TC

ASTON M.-FORD-JAGUAR-ROVER-YUGO  
CASI-CEM-CLAUSOR-KOLB-NEIMAN

**FORD**

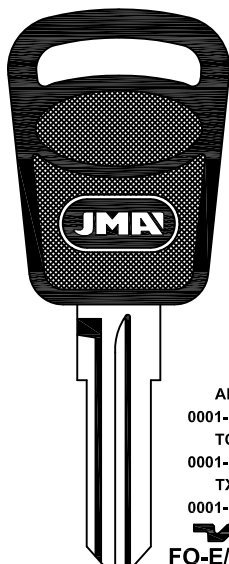

AK  
0001-1000  
TC  
0001-1000  
TX  
0001-1859

FO-E/TC.P

ASTON M.-FORD-JAGUAR-ROVER-YUGO  
CASI-CEM-CLAUSOR-KOLB-NEIMAN

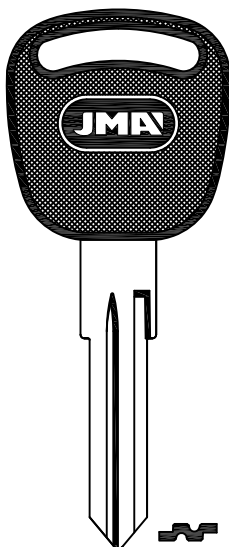

FO-FH.P

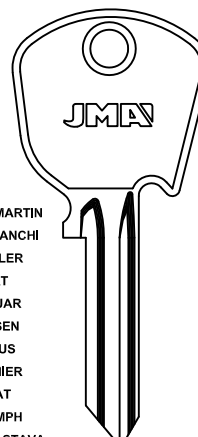

ASTON MARTIN  
AUTOBIANCHI  
DAIMLER  
FIAT  
JAGUAR  
JENSEN  
LOTUS  
PREMIER  
SEAT  
TRIUMPH  
YUGO ZASTAVA

SCANIA  
FK  
1-3040

FO-FK

ARMAN-DOM-JUGODENT-WASO

FR  
1-3040  
4001-6000

FO-FR

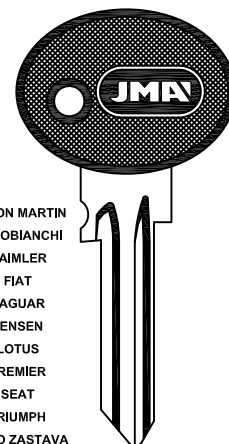

ASTON MARTIN  
AUTOBIANCHI  
DAIMLER  
FIAT  
JAGUAR  
JENSEN  
LOTUS  
PREMIER  
SEAT  
TRIUMPH  
YUGO ZASTAVA

SCANIA  
FK  
1-3040

FO-FK.P

ARMAN-DOM-JUGODENT-WASO

FR  
1-3040  
4001-6000

FO-FR.P

**FORD**

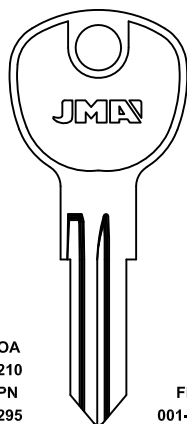

DA-OA  
001-210  
ER-PN  
101-295  
ER  
001-195  
ER  
501-695

FO-OA

DAF-EBRO-KENWORTH-VOLKSWAGEN  
CASI-HUF-YMOS

FB  
001-210  
PO  
501-695  
PO  
101-295

FO-PN

OL  
001-210  
07R  
001-195  
7OR  
001-210

FO-OL

CASI-YMOS

OB...  
1-210

VO-7

NSU

O7L  
001-195  
7OL  
001-210  
OR  
001-210

FO-OR

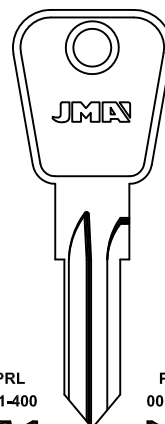

PRL  
001-400

FO-PRL

XL  
001-195

FO-XL

FORD  
CASI-YMOS

PRR  
001-400

FO-PRR

XR  
001-195

FO-XR

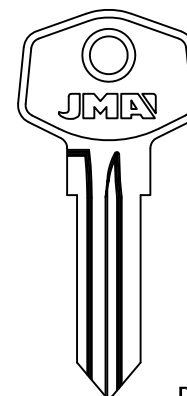

DM  
300-400  
TC-AK  
0001-1000  
TX  
0001-1859

FO-TC

DAF-DAIMLER-FORD-JAGUAR  
CASI-CEM-KOLB



# FORD

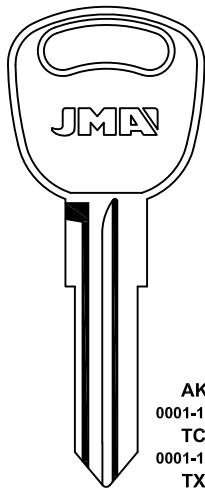

AK  
0001-1000  
TC  
0001-1000  
TX  
0001-1859



FORD

CASI-CEM-CLAUSOR-KOLB-NEIMAN

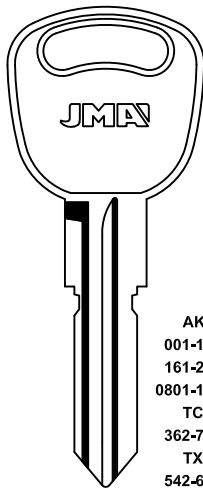

AK  
001-100  
161-250  
0801-1000  
TC  
362-728  
TX  
542-671  
1300-1601



FORD

FO-TX1



AK  
001-100  
161-250  
0801-1000  
TC  
362-728  
TX  
542-671  
1300-1601



FORD

FO-TX1.P

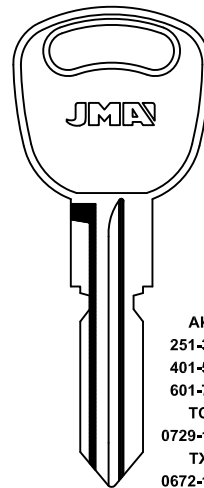

AK  
251-300  
401-500  
601-700  
TC  
0729-1000  
TX  
0672-1000  
1602-1859



FORD

FO-TX2

# PARA-FOR:

FORD (USA)

GAS (RA)

G.M. (USA)

# FORD



AK  
251-300  
401-500  
601-700  
TC  
0729-1000  
TX  
0672-1000  
1602-1859



FORD

CASI-CEM-CLAUSOR-KOLB-NEIMAN



AK  
0001-1000  
TC  
0001-1000  
TX  
0001-1859



FORD

FO-TX.P

# GAS

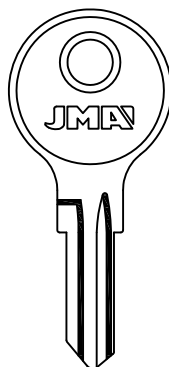

GAS-1



GAS-1D

# G.M.

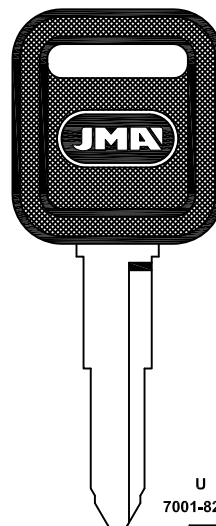

U  
7001-8200



GM-1.P

G.M.

BRIGGS STRATTON

# GENERAL MOTORS

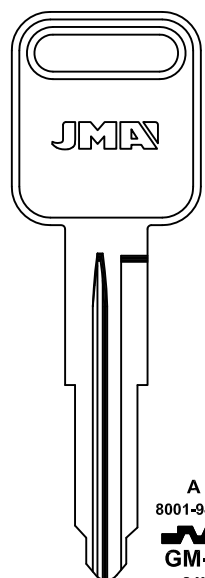

A  
8001-9400



GM-2

G.M.

BRIGGS STRATTON

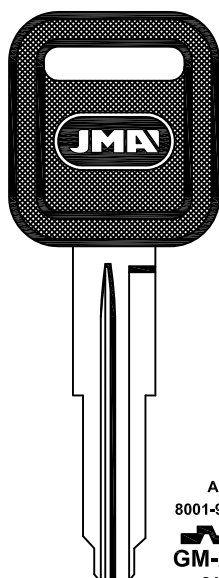

A  
8001-9400



GM-2.P

G.M.

BRIGGS STRATTON

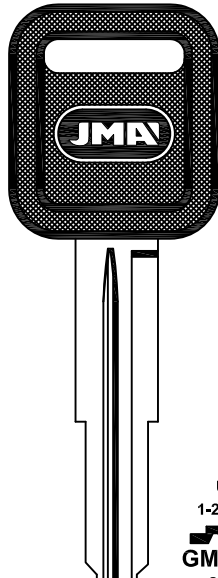

U  
1-2000



GM-3.P

G.M.

BRIGGS S.

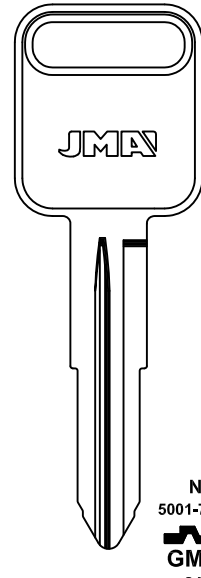

N  
5001-7000



GM-4

G.M.

BRIGGS STRATTON



PARA-FOR:

G.M. (USA)

### GENERAL MOTORS



N  
5001-7000  
  
GM-4.P  
G.M.

BRIGGS STRATTON

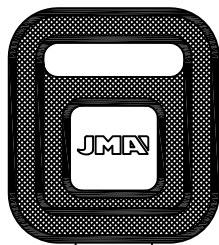

N  
5001-7000  
  
GM-4.P1  
G.M.

BRIGGS STRATTON

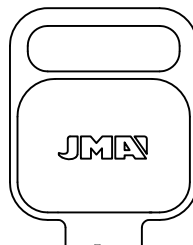

U  
1-2000  
  
GM-5  
G.M.

BRIGGS S.



U  
1-2000  
  
GM-5.P  
G.M.

BRIGGS S.

### GENERAL MOTORS



A  
000-999  
  
GM-6

E  
000-999  
  
GM-8

G.M.  
BRIGGS STRATTON

C  
000-999  
  
GM-7

J  
000-999  
  
GM-9



A  
000-999  
  
GM-6.P

E  
000-999  
  
GM-8.P

G.M.  
BRIGGS STRATTON

C  
000-999  
  
GM-7.P

J  
000-999  
  
GM-9.P

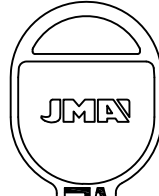

B  
000-999  
  
GM-10

H  
000-999  
  
GM-12

G.M.  
BRIGGS STRATTON

D  
000-999  
  
GM-11

K  
000-999  
  
GM-13



B  
000-999  
  
GM-10.P

H  
000-999  
  
GM-12.P

G.M.  
BRIGGS STRATTON

D  
000-999  
  
GM-11.P

K  
000-999  
  
GM-13.P

### GENERAL MOTORS

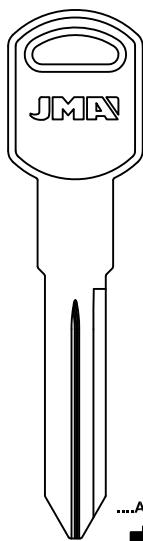

....A00-7N45  
  
GM-14

G.M.  
BRIGGS STRATTON

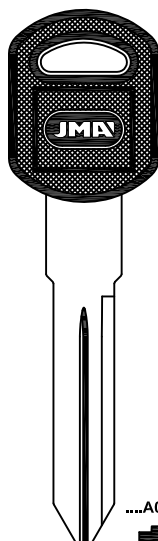

....A00-7N45  
  
GM-14.P

G.M.  
BRIGGS STRATTON

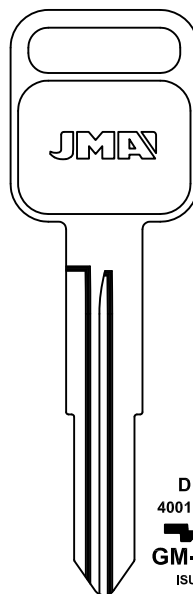

D....  
4001-6000  
  
GM-15D  
BRIGGS S.

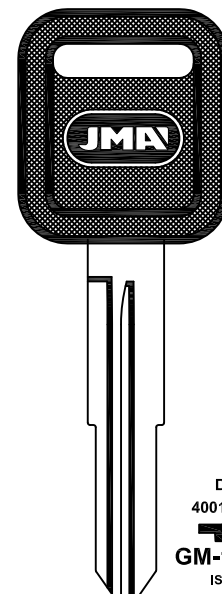

D....  
4001-6000  
  
GM-15D.P  
ISUZU  
BRIGGS S.





## GENERAL MOTORS

PARA-FOR:  
G.M. (USA)

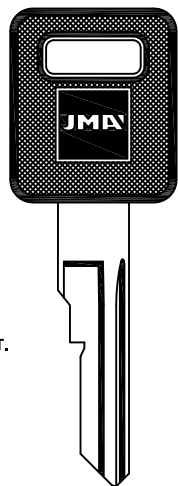

LAT.

A  
..A..0.00-9.99  
..B..0.00-9.99  
..V..0.00-9.99  
..V..0.00-9.99  
..W..0.00-9.99  
..W..0.00-9.99



**GM-16.P**

E  
..J..0.00-9.99  
..K..0.00-9.99



**GM-18.P**

G.M.

BRIGGS STRATTON

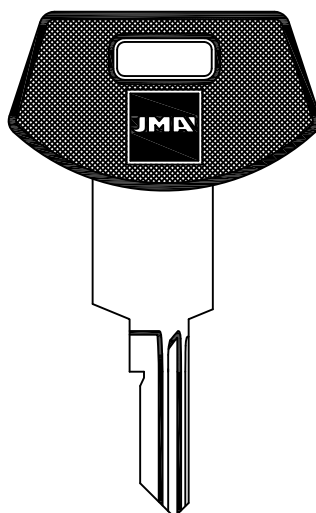

LAT.

C  
..A..0.00-9.99  
..B..0.00-9.99  
..N..0.00-9.99  
..N..0.00-9.99  
..P..0.00-9.99  
..P..0.00-9.99



**GM-17.P**

C

..A..0.00-9.99  
..B..0.00-9.99  
..N..0.00-9.99  
..N..0.00-9.99  
..P..0.00-9.99  
..P..0.00-9.99



**GM-19.P**

E

..J..0.00-9.99  
..K..0.00-9.99



**GM-20.P**

G.M.

BRIGGS STRATTON

## GENERAL MOTORS

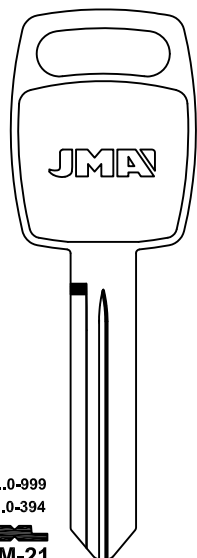

LAT.

R...0-999  
T...0-394



**GM-21**

GM

BRIGGS & STRATTON

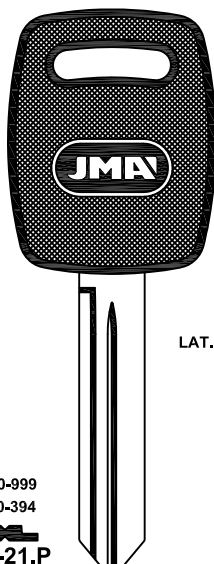

LAT.

R...0-999  
T...0-394



**GM-21.P**

GM

BRIGGS & STRATTON

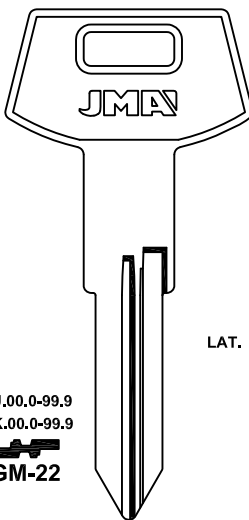

LAT.

..J..0.00-9.99  
..K..0.00-9.99



**GM-22**



**GM-23**

G.M.

BRIGGS STRATTON

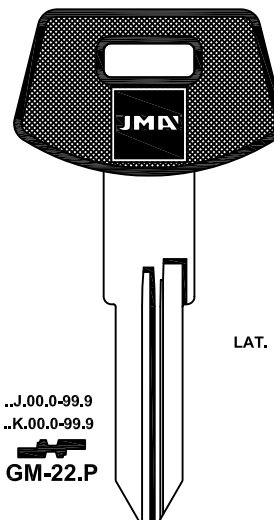

LAT.

..J..0.00-9.99  
..K..0.00-9.99



**GM-22.P**



**GM-23.P**

G.M.

BRIGGS STRATTON

## GENERAL MOTORS

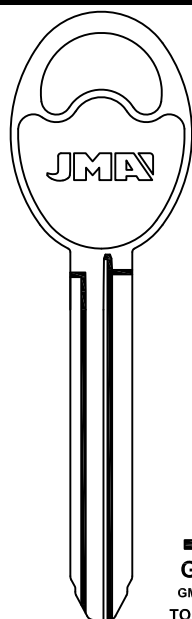

LAT.

1....  
1-5000



**GM-24**

GM-TOYOTA  
TOKAJ-RIKA

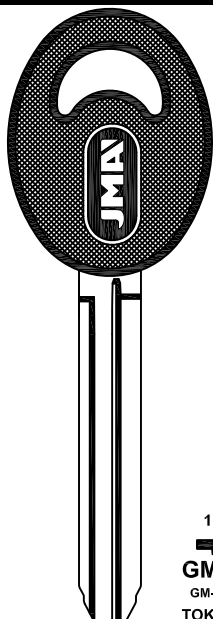

LAT.

1....  
1-5000



**GM-24.P**

GM-TOYOTA  
TOKAJ-RIKA

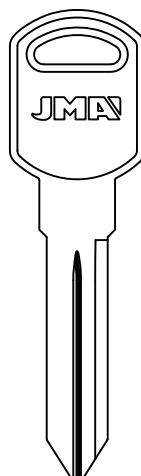

G.M.

BRIGGS STRATTON

....A00-7N45



**GM-25**

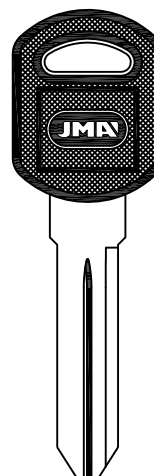

G.M.

BRIGGS STRATTON

....A00-7N45



**GM-25.P**



**PARA-FOR:**

G.M. (USA)

GEWU (D)

GHE (D)

**GENERAL MOTORS**

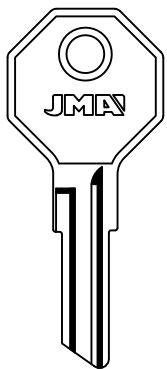

**GM-26**

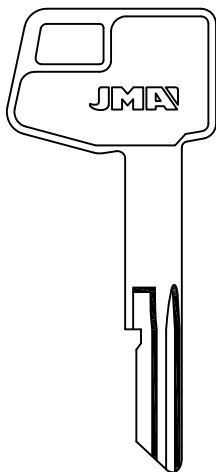

0000-1999  
**GM-42**

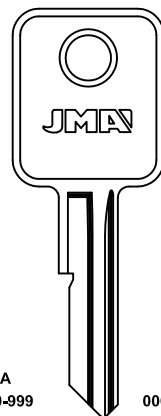

A  
000-999  
**GM-A**

E  
000-999  
**GM-E**



C  
000-999  
**GM-C**

J  
000-999  
**GM-J**

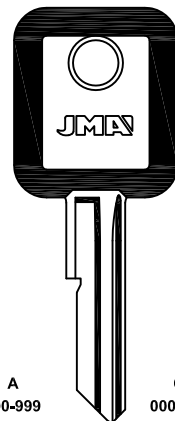

A  
000-999  
**GM-A.P**

E  
000-999  
**GM-E.P**

C  
000-999  
**GM-C.P**

J  
000-999  
**GM-J.P**

G.M.  
BRIGGS STRATTON

G.M.  
BRIGGS STRATTON

**GENERAL MOTORS**

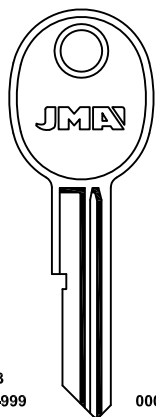

B  
000-999  
**GM-B**

H  
000-999  
**GM-H**

G.M.  
BRIGGS STRATTON

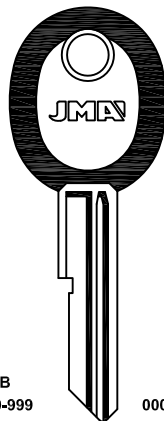

D  
000-999  
**GM-D**

K  
000-999  
**GM-K**

G.M.  
BRIGGS STRATTON

**GEWU**

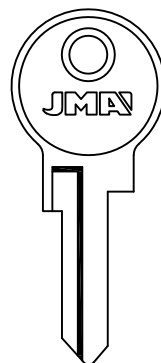

**GW-1D**

ZUNDAPP

**GHE**

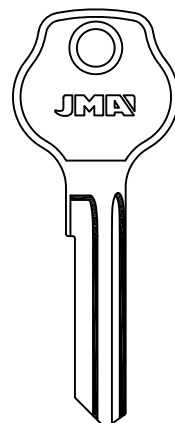

**GH-1**

**GHE**

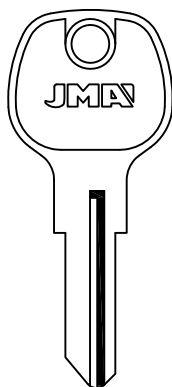

GY  
25-90  
**GH-2**

PEROHAUS-POS-WECO

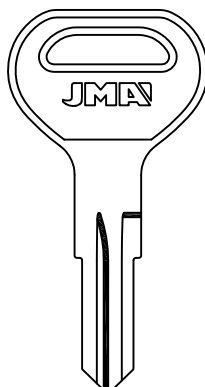

LS 378-616  
**GH-3**

KASSBOHRER

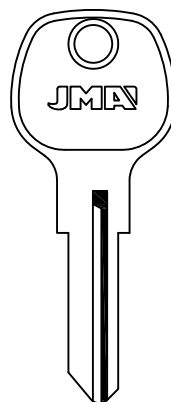

GX  
091-320  
**GH-GX**

PEROHAUS-POS-WECO

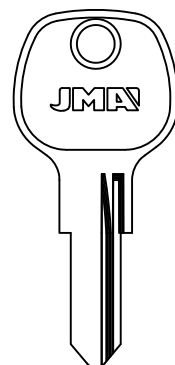

HX  
091-320  
**GH-HX**

PS  
139  
**GH-PS**



# GIOBERT

PARA-FOR:

GIOBERT (I)

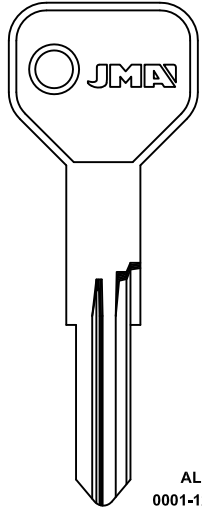

AL  
0001-1274



ALFA ROMEO  
YMOS

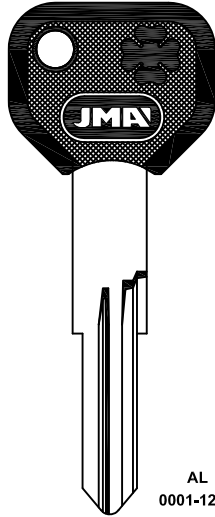

AL  
0001-1274



AF-13.P

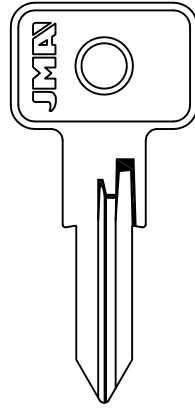

K-H  
7001-8092



AF-14

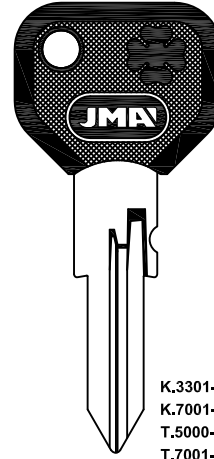

K-H  
7001-8092



AF-14.P

ARMAN-CLAUSOR

FIST-M.MARELLI-NEIMAN-SIPEA

K.3301-4886  
K.7001-8092  
T.5000-6027  
T.7001-8092  
S.0501-3278  
H.7001-8092



FI-6I.P4

# GIOBERT

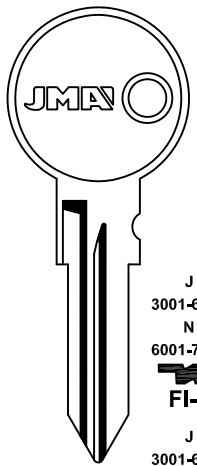

J  
3001-6732  
N  
6001-7000



FI-1

J  
3001-6732  
N  
6001-7000



FI-10

AUTOBIANCHI-FIAT-LANCIA  
RAYTON FISSORE-STREYR PUCH  
CAGIVA-GILERA-PIAGGIO VESPA

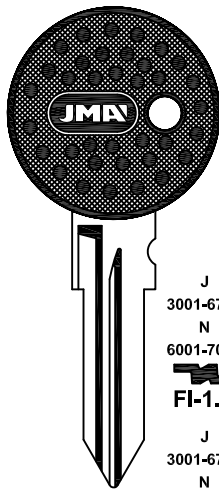

J  
3001-6732  
N  
6001-7000



FI-1.P

J  
3001-6732  
N  
6001-7000



FI-10.P

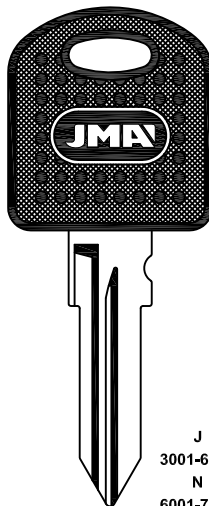

J  
3001-6732  
N  
6001-7000



FI-1.P8

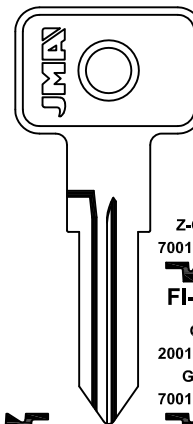

Z-GR  
7001-9956



FI-2D

G  
2001-4530

G-Z  
7001-9956



FI-3D

G  
7001-9956



FI-12

A. ROMEO-AUTOBIANCHI-CITROEN-FIAT  
INNOCENTI-LANCIA-PEUGEOT-SEAT  
YUGO ZASTAVA-FIAT IVECO

# GIOBERT

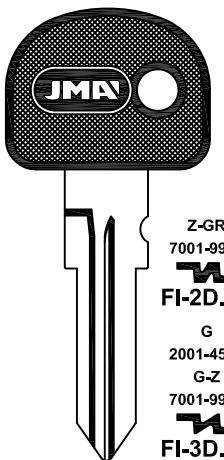

Z-GR  
7001-9956

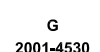

FI-2D.P3

G  
2001-4530  
G-Z  
7001-9956



FI-3D.P3

G  
7001-9956



FI-12.P3

A. ROMEO-AUTOBIANCHI-CITROEN-FIAT  
LANCIA-PEUGEOT-SEAT

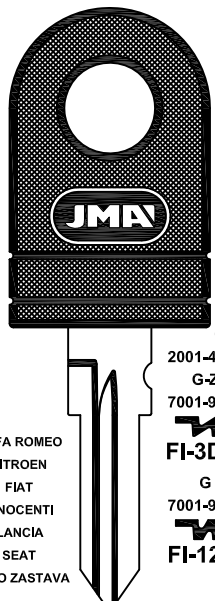

G  
2001-4530  
G-Z  
7001-9956



FI-3D.P

G  
7001-9956



FI-12.P

ALFA ROMEO  
CITROEN  
FIAT  
INNOCENTI  
LANCIA  
SEAT  
YUGO ZASTAVA

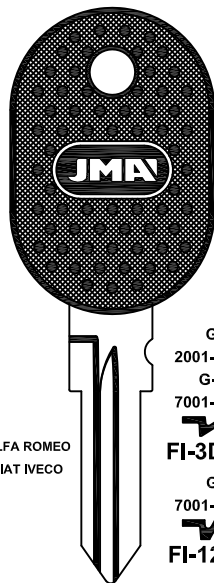

G  
2001-4530  
G-Z  
7001-9956



FI-3D.P1

G  
7001-9956



FI-12.P1

ALFA ROMEO  
FIAT IVECO

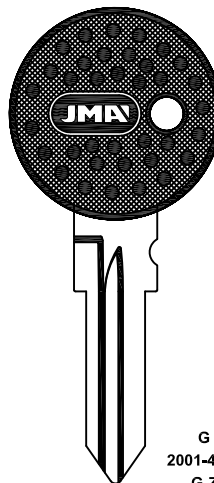

G  
2001-4530  
G-Z  
7001-9956



FI-3D.P2

FIAT



PARA-FOR:

GIOBERT (I)

GIOBERT

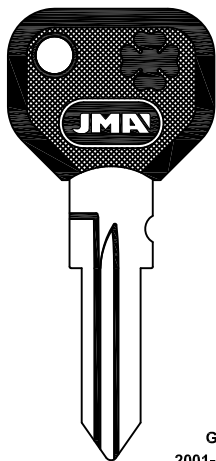

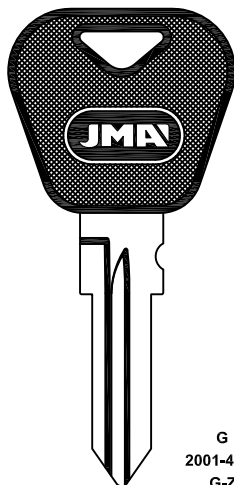

G  
2001-4530  
G-Z  
7001-9956  
  
FI-3D.P4  
ALFA ROMEO

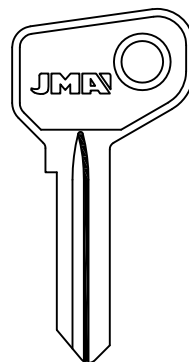

G  
2001-4530  
G-Z  
7001-9956  
  
FI-3D.P5  
INNOCENTI-YUGO ZASTAVA



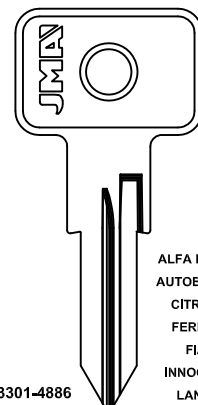

  
FI-4D  
 FI-5I  
 FI-5D  
OM IVECO-FIAT IVECO  
IACAM

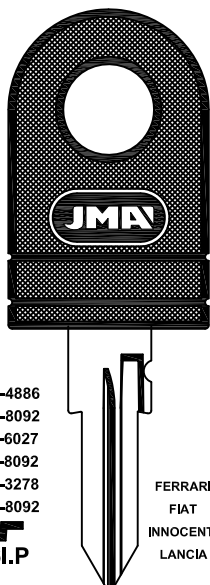

K 3301-4886  
K 7001-8092  
T 5000-6027  
T 7001-8092  
S 0501-3278  
H 7001-8092  
  
FI-6I  
ALFA ROMEO  
AUTOBIANCHI  
CITROEN  
FERRARI  
FIAT  
INNOCENTI  
LANCIA  
PEUGEOT  
YUGO ZASTAVA  
CAGIVA  
DUCATI  
FANTIC MOTOR  
GARELLI  
GILERA

GIOBERT



K 3301-4886  
K 7001-8092  
T 5000-6027  
T 7001-8092  
S 0501-3278  
H 7001-8092  
  
FI-6I.P  
FERRARI  
FIAT  
INNOCENTI  
LANCIA



K 3301-4886  
K 7001-8092  
T 5000-6027  
T 7001-8092  
S 0501-3278  
H 7001-8092  
  
FI-6I.P1  
A. ROMEO  
FIAT IVECO

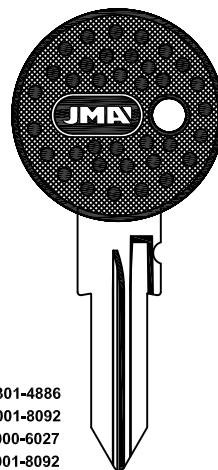

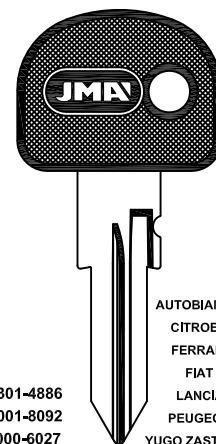

K 3301-4886  
K 7001-8092  
T 5000-6027  
T 7001-8092  
S 0501-3278  
H 7001-8092  
  
FI-6I.P2  
FERRARI  
FIAT  
CAGIVA



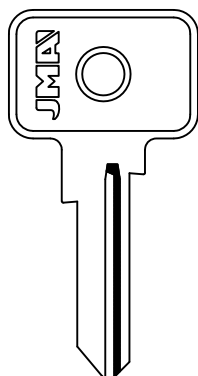

K 3301-4886  
K 7001-8092  
T 5000-6027  
T 7001-8092  
S 0501-3278  
H 7001-8092  
  
FI-6I.P3  
AUTOBIANCHI  
CITROEN  
FERRARI  
FIAT  
LANCIA  
PEUGEOT  
YUGO ZASTAVA  
CAGIVA  
DUCATI  
FANTIC MOTOR  
GARELLI  
GILERA

GIOBERT

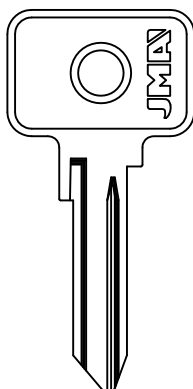

X  
3301-4886  
  
FI-7I  
FIAT  
NEIMAN-SIPEA



Y  
7001-9956  
  
FI-8I  
AUTOBIANCHI-FIAT-SEAT  
ARMAN

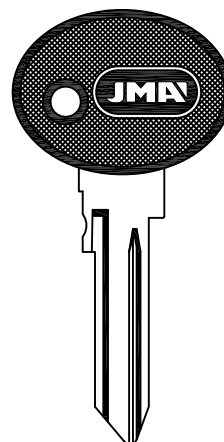

Y  
7001-9956  
  
FI-8I.P  
AUTOBIANCHI-FIAT-SEAT  
ARMAN

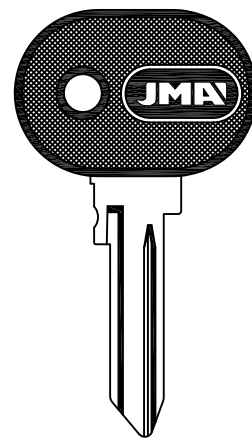

Y  
7001-9956  
  
FI-8I.P1  
FIAT-FIAT IVECO  
ARMAN



## GIOBERT

PARA-FOR:

GIOBERT (I)

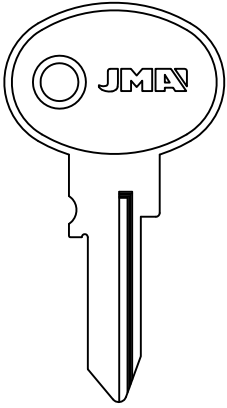

M  
0001-1050  
  
FI-9I

ALFA ROMEO-AUTOBIANCHI-FIAT-LANCIA  
OM IVECO-SEAT-STEYR PUCH

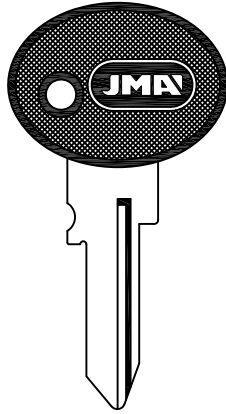

M  
0001-1050  
  
FI-9I.P

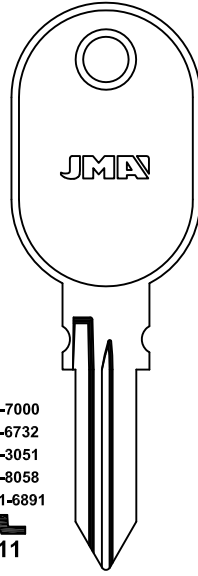

N 6001-7000  
J 3001-6732  
V 0001-3051  
V 5001-8058  
AB 6001-6891  
  
FI-11

AUTOBIANCHI-FIAT-INNOCENTI-LANCIA  
RAYTON FISSORE-STEYR PUCH-APRILIA

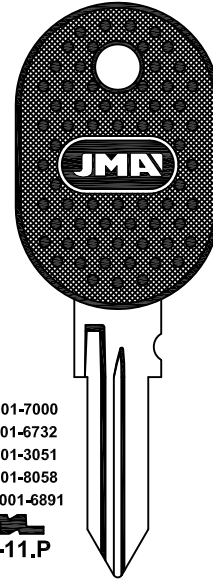

N 6001-7000  
J 3001-6732  
V 0001-3051  
V 5001-8058  
AB 6001-6891  
  
FI-11.P

## GIOBERT

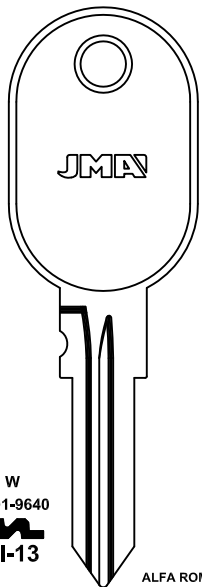

W  
0001-9640  
  
FI-13

ALFA ROMEO-FIAT-LANCIA

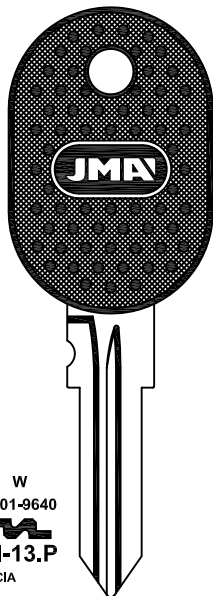

W  
0001-9640  
  
FI-13.P

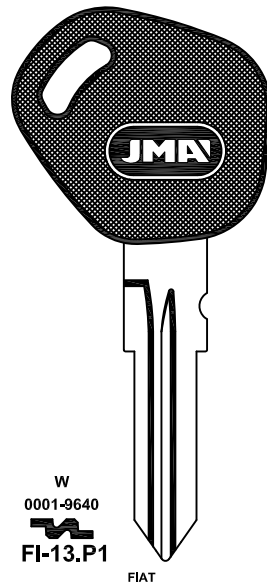

W  
0001-9640  
  
FI-13.P1

FIAT

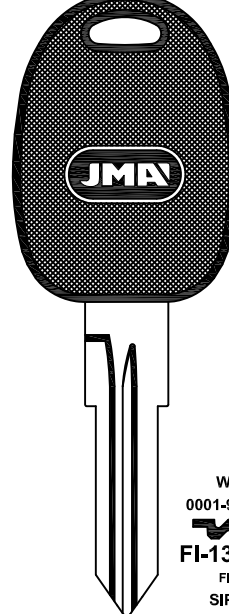

W  
0001-9640  
  
FI-13.P7  
FIAT  
SIPEA

## GIOBERT

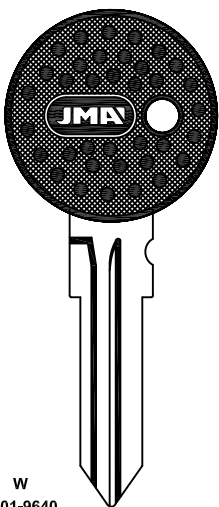

W  
0001-9640  
  
FI-14.P

ALFA ROMEO-FIAT-LANCIA

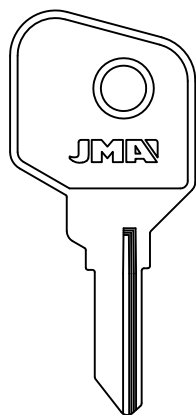

FI-15

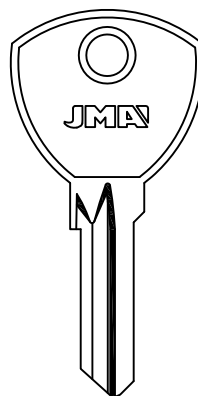

GIOB-2I

LANCIA-MASERATI



GIOB-1D

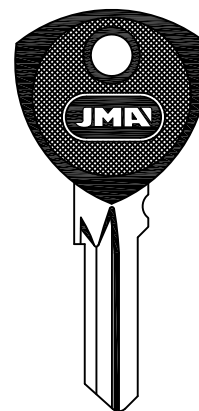

GIOB-2I.P

LANCIA-MASERATI



GIOB-1D.P

**JMA**<sup>®</sup>





Copyright by Alejandro Altuna S.A. 2014







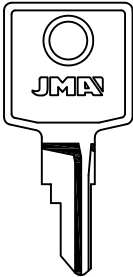

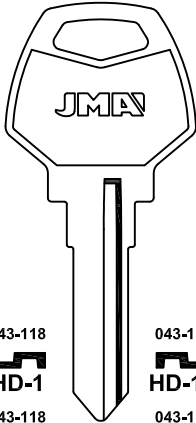
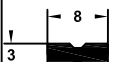
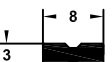

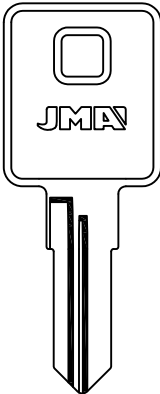

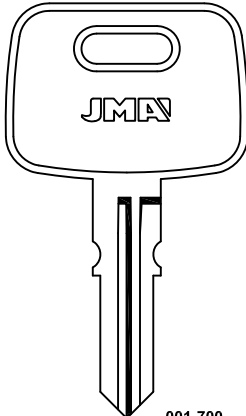

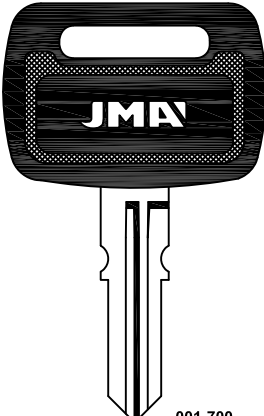

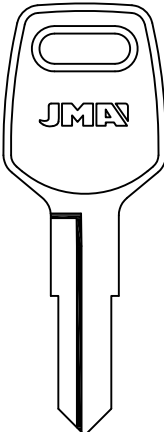

ATENCIÓN: Concerniente a las marcas y denominaciones comerciales ver nota en índice.  
ATTENTION: Concerning the marks and commercial denominations see note in index.  
ATTENTION: Concernant les marques et dénominations commerciales voir la note dans l'index.  
ACHTUNG: Beziehen auf die marke und handelsname sehen sie die notiz im index.

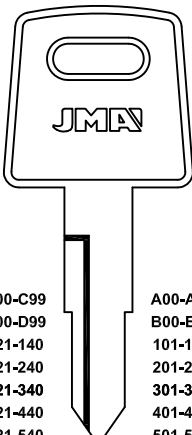
**PARA-FOR:**

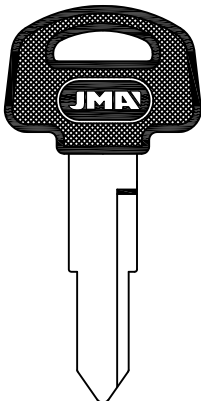
- GIOBERT (I)
- HAMA (D)
- HARLEY DAV. (USA)
- HONDA (J)

| GIOBERT  | HAMA  | HARLEY DAV.   |
|--|---|---|
| <br>                                   | <br>                                |                                  |
| <p>ALP.<br/>ALFA ROMEO<br/>LA FORZA<br/>LANCIA<br/>RAYTON FISSORE<br/>0001-1530</p>  <p><b>GIOB-3.P</b></p> <p>SAFE</p> | <p>ALP.<br/>ALFA ROMEO<br/>LA FORZA<br/>LANCIA<br/>RAYTON FISSORE<br/>0001-1530</p>  <p><b>GIOB-3.P2</b></p> <p>SAFE</p> | <p>751-762<br/><b>HA-1I</b></p> <p>778-789<br/><b>HA-1D</b></p> <p>FORD<br/>BLAU</p>                                |
|  |   | <p>043-118<br/><b>HD-1</b></p> <p>043-118<br/><b>HD-2</b></p> <p>043-118<br/><b>HD-3</b></p> <p>HARLEY DAVIDSON</p> |

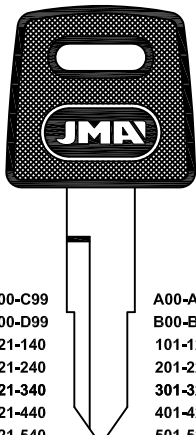
| HARLEY DAV.   | HONDA  |   |  |
|---|--|---|--|
| <br> <p><b>HD-4D</b></p> | <br> <p>001-700<br/><b>HOND-1</b></p>  <p>001-700<br/><b>HOND-2</b></p> <p>HONDA-TRIUMPH</p> | <br> <p>001-700<br/><b>HOND-1.P</b></p>  <p>001-700<br/><b>HOND-2.P</b></p> <p>HONDA-TRIUMPH</p> | <br> <p>1 AL 4<br/><b>HOND-3I</b> <b>HOND-3D</b></p> <p>HONDA</p> |

| HONDA   |   |  |   |
|---|---|--|---|
| <br> <p><b>HOND-4I</b></p> <p>HONDA</p>   | <br> <p><b>HOND-25.P2</b></p>  <p><b>HOND-30.P2</b></p> <p>HONDA</p> | <p>A00-A99<br/>B00-B99<br/>101-120<br/>201-220<br/>301-320<br/>401-420<br/>501-520<br/>601-620<br/>701-720<br/>801-820</p>  <p><b>HOND-4D.P2</b></p>  <p><b>HOND-30D.P2</b></p> | <br> <p><b>HOND-4I.P</b></p> <p>HONDA</p>                                   |
| <p>C00-C99<br/>D00-D99<br/>121-140<br/>221-240<br/>321-340<br/>421-440<br/>521-540<br/>621-640<br/>721-740<br/>821-840</p> <p>A00-A99<br/>B00-B99<br/>101-120<br/>201-220<br/>301-320<br/>401-420<br/>501-520<br/>601-620<br/>701-720<br/>801-820</p> |   | <p>A00-A99<br/>B00-B99<br/>101-120<br/>201-220<br/>301-320<br/>401-420<br/>501-520<br/>601-620<br/>701-720<br/>801-820</p>   | <p>C00-C99<br/>D00-D99<br/>121-140<br/>221-240<br/>321-340<br/>421-440<br/>521-540<br/>621-640<br/>721-740<br/>821-840</p> <p>A00-A99<br/>B00-B99<br/>101-120<br/>201-220<br/>301-320<br/>401-420<br/>501-520<br/>601-620<br/>701-720<br/>801-820</p> |



# HONDA

PARA-FOR:  
HONDA (J)

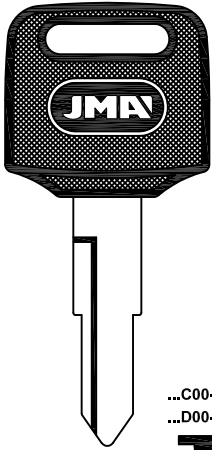

...C00-C99  
...D00-D99  
**HOND-4I.P1**

...A00-A99  
...B00-B99  
**HOND-4D.P1**

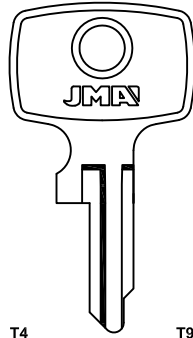

T4  
**HOND-5I**

T9  
**HOND-5D**

T1  
**HOND-6I**

2 AL 9  
3 AL 6  
T6  
**HOND-6D**

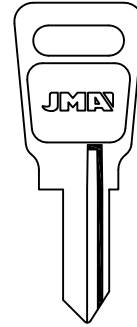

**HOND-18.P**  
HONDA

**HOND-18D.P**

T3  
**HOND-7I**  
HONDA

T8  
**HOND-7D**  
HONDA

**HOND-8I**  
HONDA

**HOND-8D**  
HONDA

# HONDA

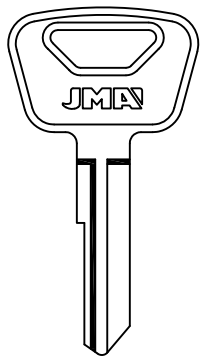

**HOND-9I**  
HONDA

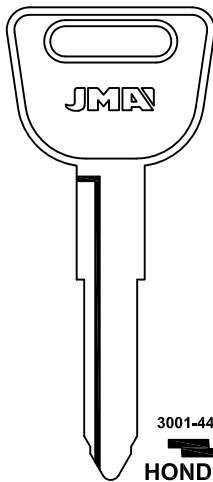

3001-4481  
**HOND-10**

3001-4481  
**HOND-11**  
ACURA-HONDA-ROVER



3001-4481  
**HOND-10.P**

3001-4481  
**HOND-11.P**  
ACURA-HONDA-ROVER

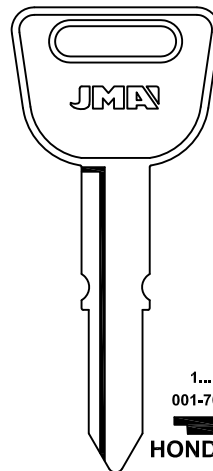

1...  
001-700  
**HOND-12**

2...  
001-700  
**HOND-13**  
HONDA

# HONDA

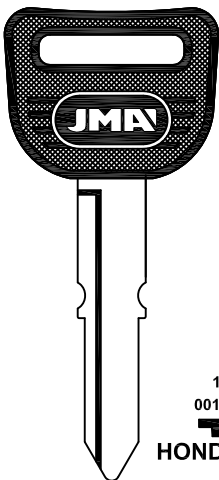

1...  
001-700  
**HOND-12.P**

2...  
001-700  
**HOND-13.P**  
HONDA

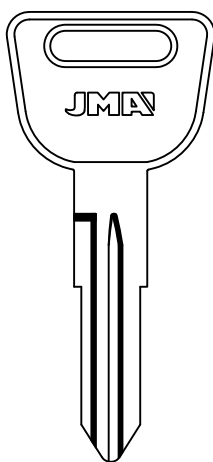

5001-8442  
**HOND-14**  
HONDA

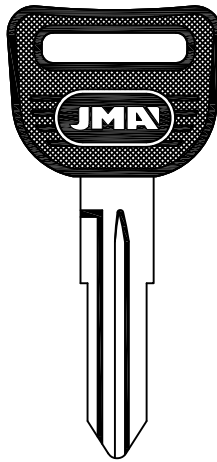

5001-8442  
**HOND-14.P**  
HONDA

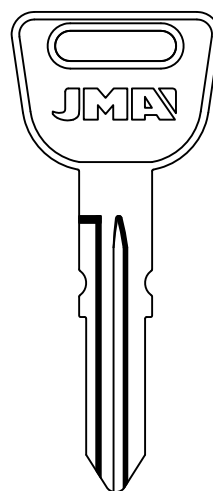

5001-8442  
**HOND-15**  
ACURA-HONDA



PARA-FOR:

HONDA (J)

HONDA

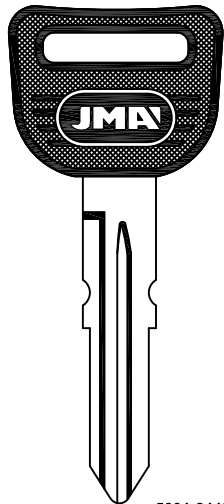

5001-8442

HOND-15.P

ACURA-HONDA

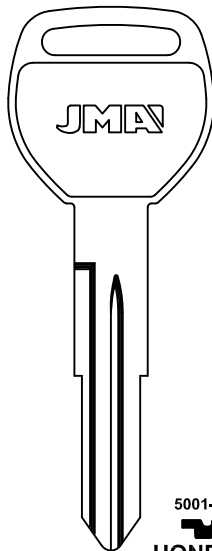

5001-8442

HOND-16D

ACURA-HONDA

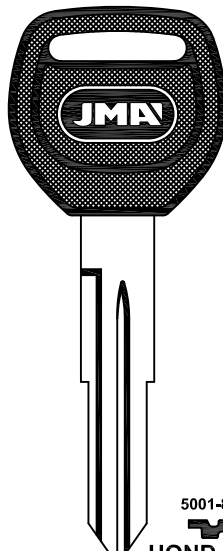

5001-8442

HOND-16D.P

ACURA-HONDA

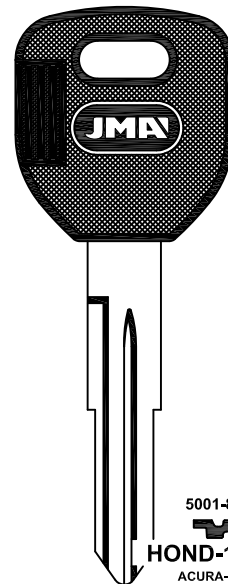

5001-8442

HOND-16D.P1

ACURA-HONDA

HONDA

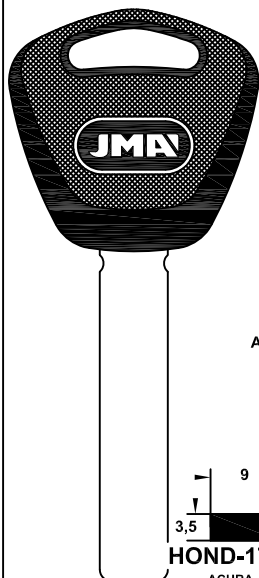

ALP.

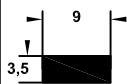

HOND-17.P

ACURA

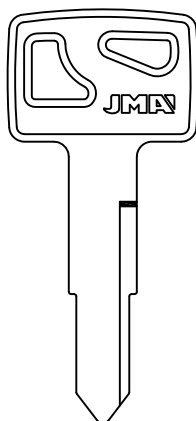

...A00-A99  
...B00-B99

HOND-19

HONDA

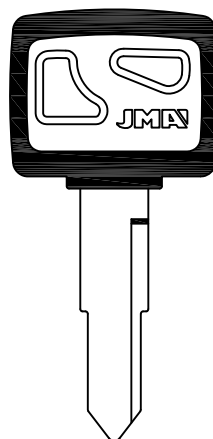

...A00-A99  
...B00-B99

HOND-19.P

HONDA

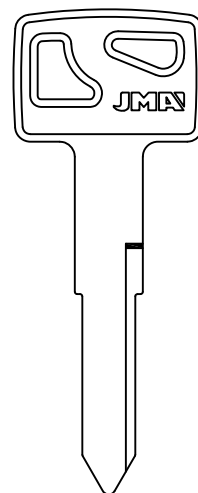

.....1 AL 3

HOND-20

HONDA

HONDA

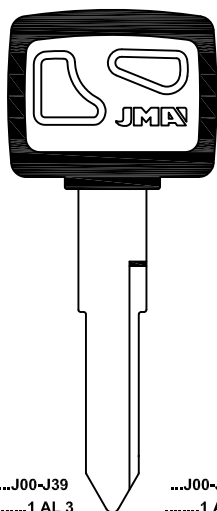

...J00-J39  
.....1 AL 3

HOND-20.P

HONDA

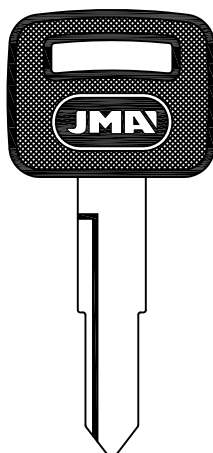

HOND-22D.P

HONDA

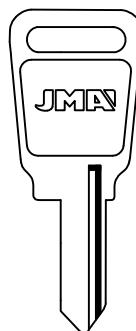

HOND-23

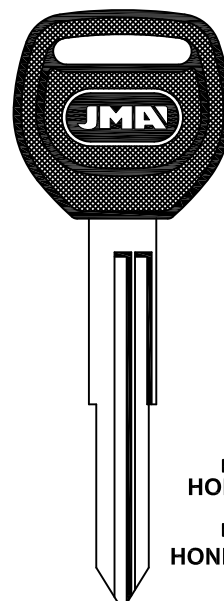

HOND-24.P

HOND-24D.P





## HONDA

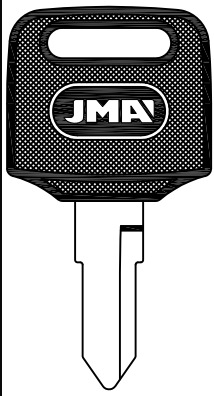

HOND-26.P1

HOND-26D.P1

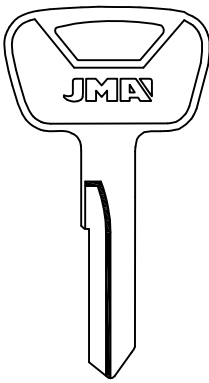

HOND-27D

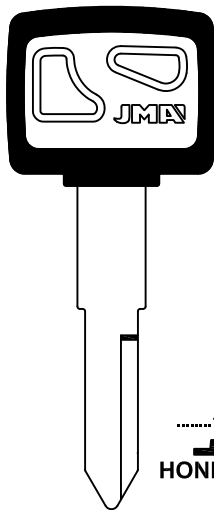

.....1 AL 3  
HOND-28.P  
HOND-28D.P  
HONDA

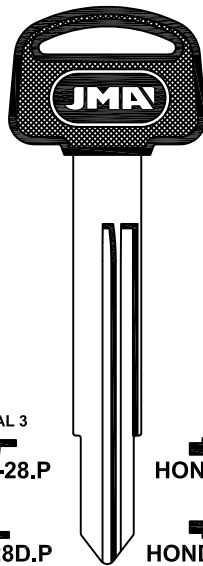

HOND-29.P

HOND-29D.P

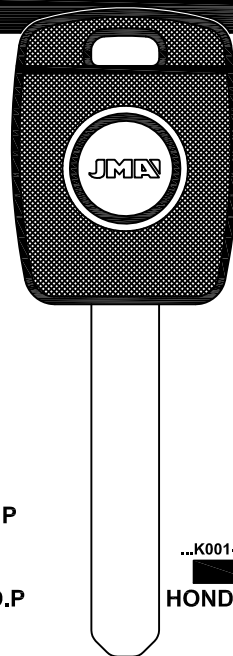

ALP.  
...K001-N718  
HOND-31.P

## HONDA

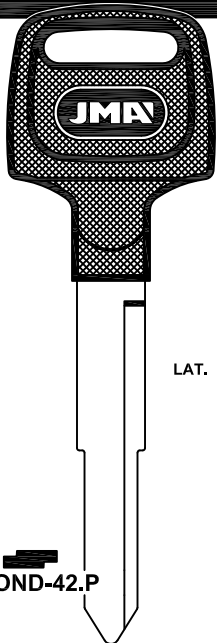

HOND-42.P

LAT.

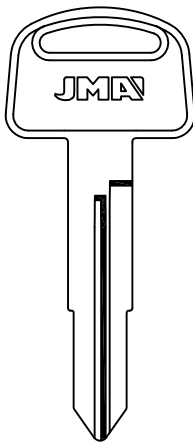

A..00-99  
HOND-43

HOND-43D

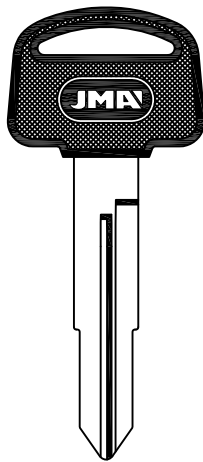

A..00-99  
HOND-43.P

HOND-43D.P

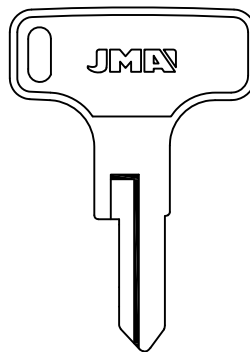

30B-34A  
H....0-7-8-9  
HOND-49

20B-24A  
H....0-4-5-6  
HOND-45D

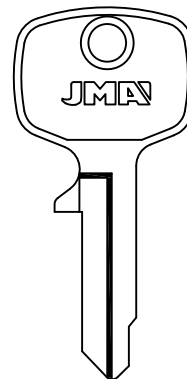

HOND-46D

## HUDSON

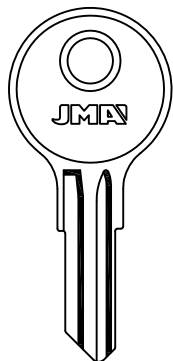

A....201-1050  
C...500-699  
H....601-1100  
HM....201-1050

HUD-1



HUD-1D

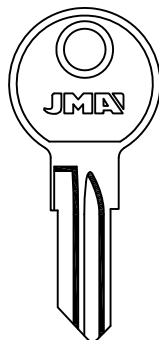

HUD-2D

## HUF

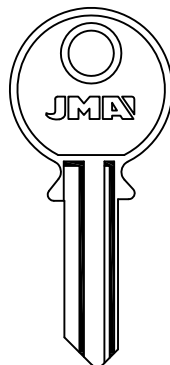

48-I

48-D

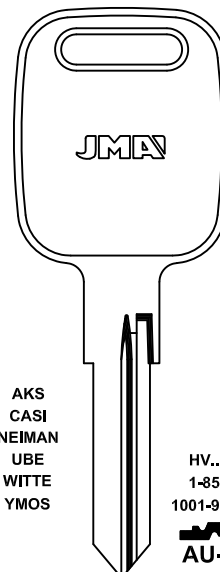

AKS  
CASI  
NEIMAN  
UBE  
WITTE  
YMOS

HV....  
1-854  
1001-9282

AU-1

AUDI  
VOLKSWAGEN-SCANIA

PARA-FOR:  
HONDA (J)  
HUDSON (USA)  
HUF (D)



PARA-FOR:

HUF (D)

HUF

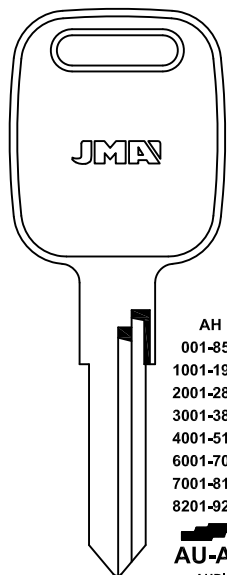

AH  
001-854  
1001-1918  
2001-2830  
3001-3890  
4001-5151  
6001-7086  
7001-8154  
8201-9282

**AU-AH**  
AUDI

AKS-CASI-UBE-WITTE

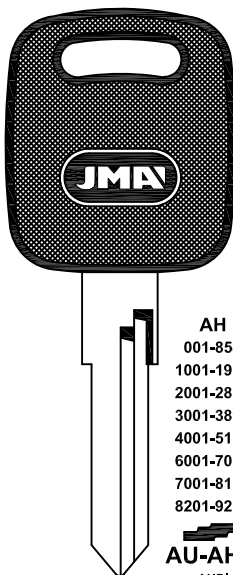

AH  
001-854  
1001-1918  
2001-2830  
3001-3890  
4001-5151  
6001-7086  
7001-8154  
8201-9282

**AU-AH.P**  
AUDI

AKS-CASI-UBE-WITTE

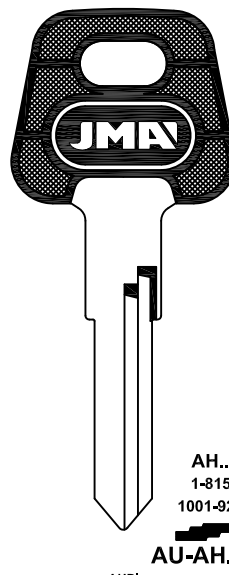

AH...  
1-8154  
1001-9282

**AU-AH.P1**  
AUDI

WITTE

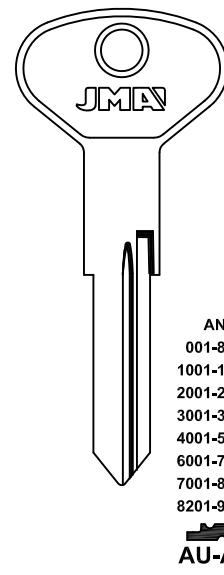

AN  
001-854  
1001-1918  
2001-2830  
3001-3890  
4001-5151  
6001-7086  
7001-8154  
8201-9282

**AU-AN**  
AUDI-VOLKSWAGEN

AKS-CASI-UBE-WITTE

HUF

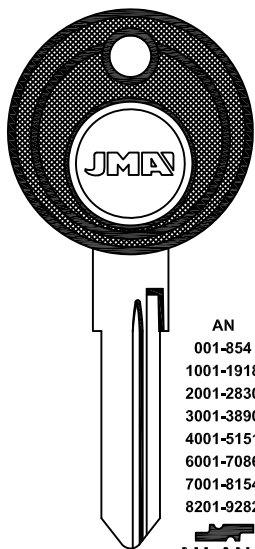

AN  
001-854  
1001-1918  
2001-2830  
3001-3890  
4001-5151  
6001-7086  
7001-8154  
8201-9282

**AU-AN.P**

AUDI-FORD-PORSCHE-VOLKSWAGEN  
AKS-CASI-UBE-WITTE

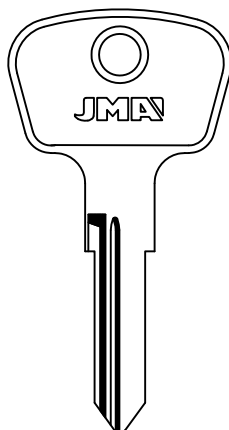

C  
01-32/01-62

**AU-C**

AUDI  
AKS

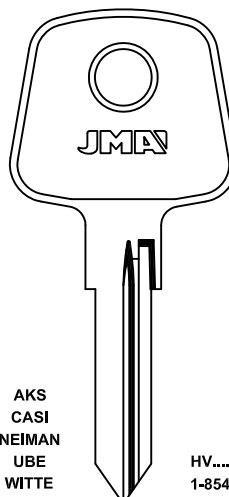

AKS  
CASI  
NEIMAN  
UBE  
WITTE  
YMOS

HV...  
1-854  
1001-9282

**AU-HV**

AUDI-VOLKSWAGEN-SCANIA

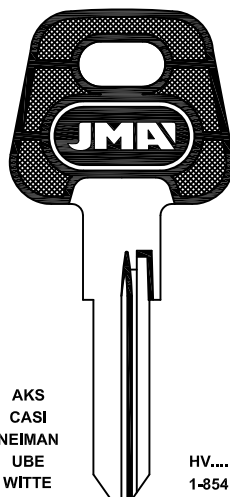

AKS  
CASI  
NEIMAN  
UBE  
WITTE  
YMOS

HV...  
1-854  
1001-9282

**AU-HV.P**

AUDI-VOLKSWAGEN-SCANIA

HUF

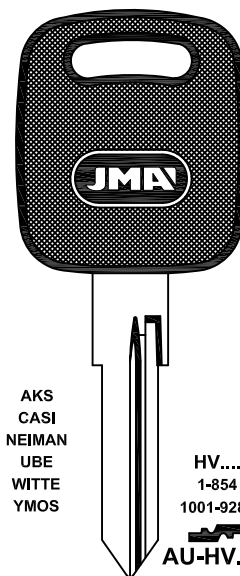

AKS  
CASI  
NEIMAN  
UBE  
WITTE  
YMOS

HV...  
1-854  
1001-9282

**AU-HV.P1**

AUDI

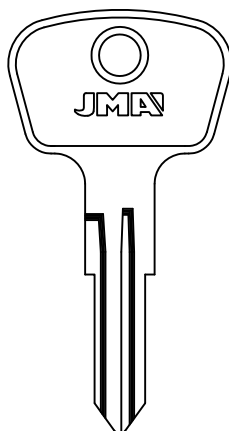

W  
11-91/11-91

**AU-W**

AUDI-VOLKSWAGEN  
AKS-WITTE

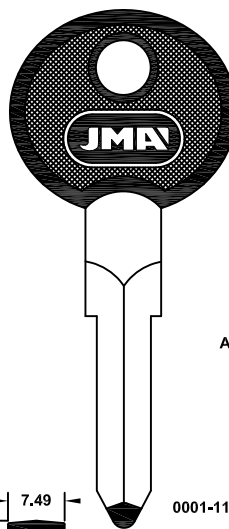

ALP.

7.49  
2.7  
**BM-1.P**

BMW  
PEBRA

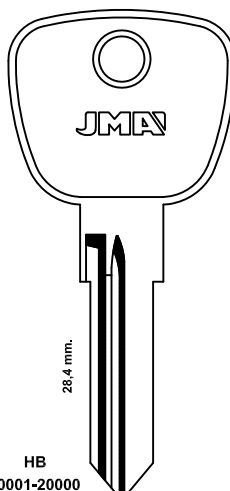

28.4 mm.

HB  
10001-20000  
40001-49999

**BM-2**

BMW



# HUF

PARA-FOR:

HUF (D)

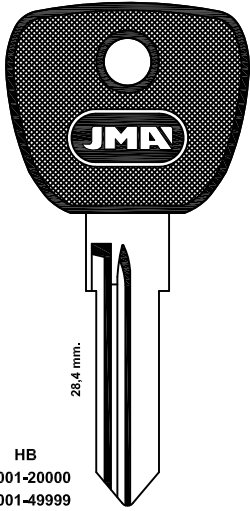

HB  
10001-20000  
40001-49999

BM-2.P

BMW

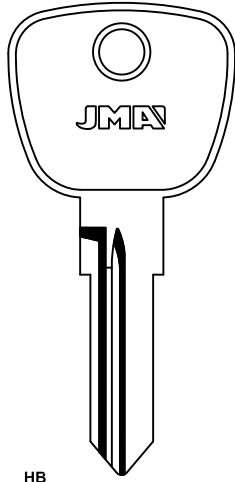

HB  
1-5000

BM-3

BMW

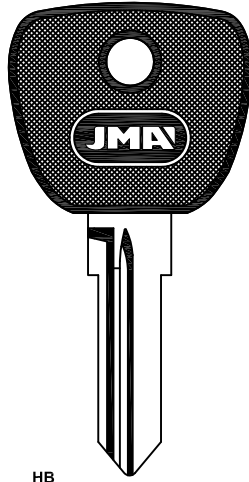

HB  
1-5000

BM-3.P

BMW

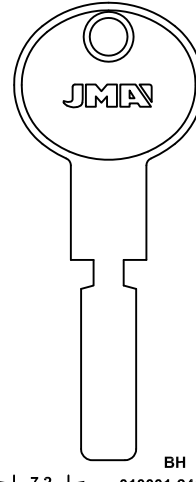

7,2  
3,5

BM-4

BMW  
TIBBE

BH  
010001-241009

# HUF

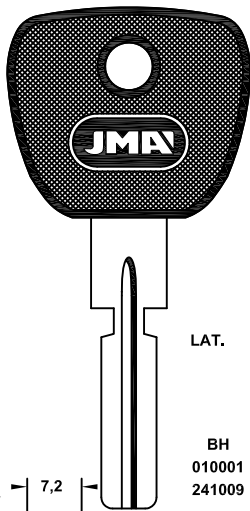

7,2  
3,5

BM-5.P

BMW  
TIBBE

LAT.

BH  
010001  
241009

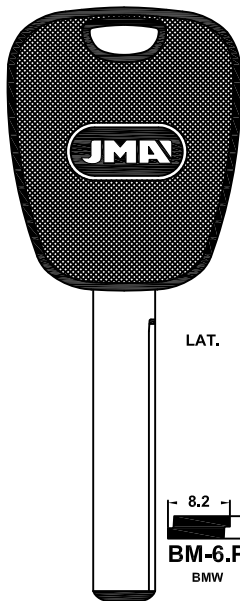

8,2  
2,95

BM-6.P

BMW

LAT.

PARA  
FOR  
BM-6RKE  
TP

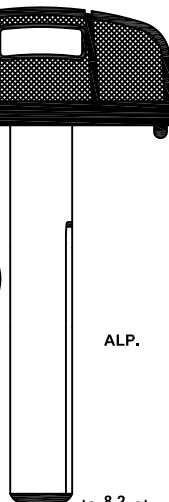

8,2  
2,95

BM-6.P1C1

BMW

ALP.

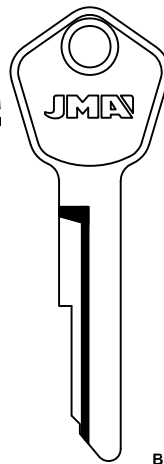

B  
101-300  
401-630

BM-B

BMW  
WITTE

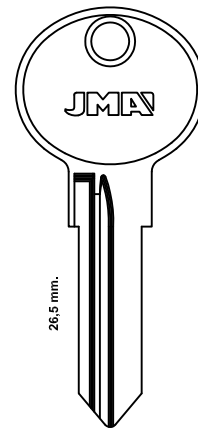

26,5 mm.

HB  
1-5000

BM-HB

BMW

NB  
1-5000

BM-NB

# HUF

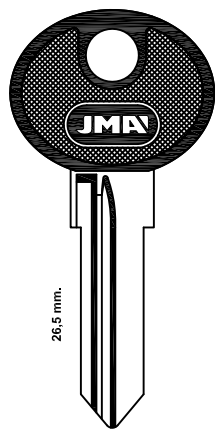

26,5 mm.

HB  
1-5000

BM-HB.P

BMW

NB  
1-5000

BM-NB.P

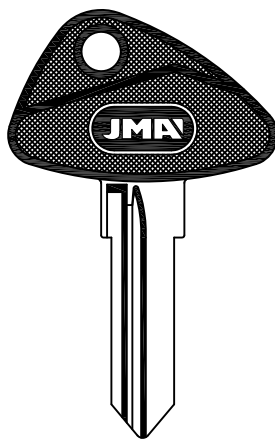

H....P  
12353-53425

BM-HB.P1

NEIMAN

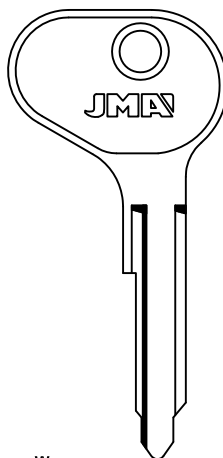

W  
1001-2020  
7001-8000

BM-W

BMW



....1-4000

FO-24C1

ALP.



PARA-FOR:

HUF (D)

HUF



ALP.

....1-4000  
FO-24C2

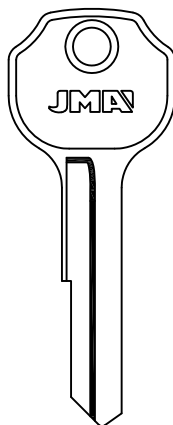

KST...1-240  
ST...1-240  
TST...1-240  
FO-SR  
FORD EUROPA

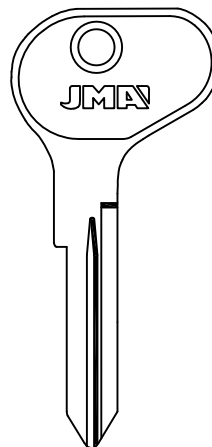

HU-1

NEIMAN-WITTE-YMOS

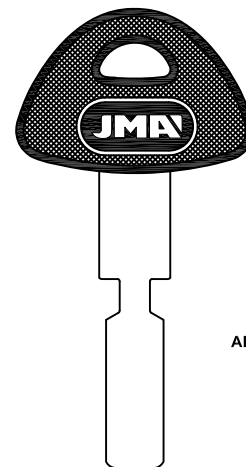

ALP.

....  
1-2000  
7,6  
3,5  
HU-2.P  
SCANIA

HUF

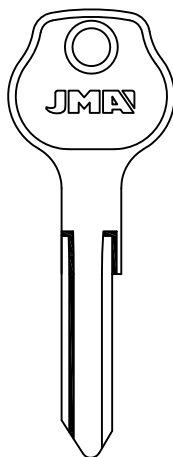

Z  
HU-3

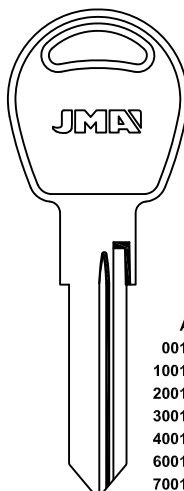

AN  
001-854  
1001-1918  
2001-2830  
3001-3890  
4001-5151  
6001-7086  
7001-8154  
8201-9282  
HU-AN

VOLKSWAGEN  
AKS-CASI-UBE-WITTE

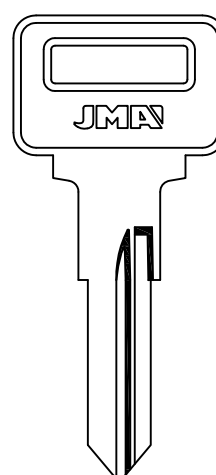

DF-F  
0001-1975  
HU-DF

VOLVO

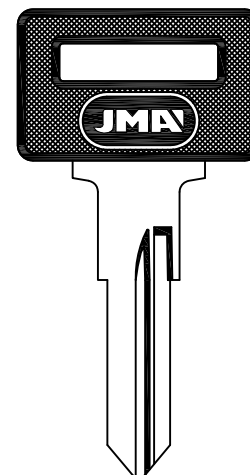

DF-F  
0001-1975  
HU-DF.P

VOLVO

HUF

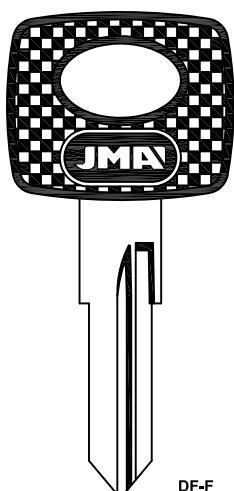

DF-F  
0001-1975  
HU-DF.P1  
VOLVO

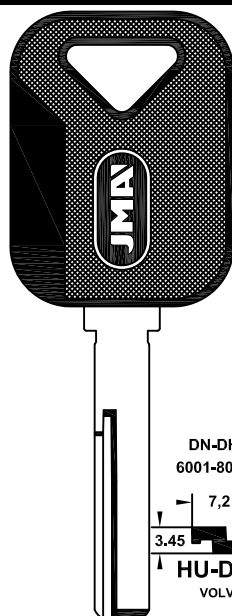

LAT.

DN-DH  
6001-8000  
7,2  
3,45  
HU-DH.P  
VOLVO

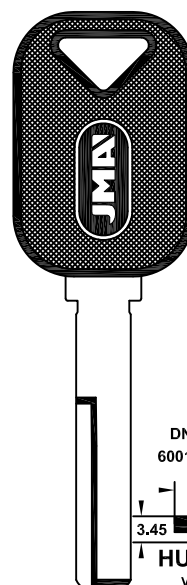

LAT.

DN-DH  
6001-8000  
7,2  
3,45  
HU-DN.P  
VOLVO

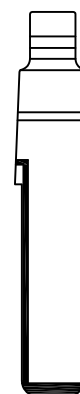

ALP.

HU-HAAC1



# HUF

PARA-FOR:

HUF (D)

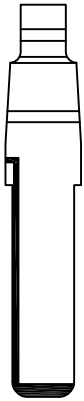

ALP.

HU-HAAC2

HU-NAAC2

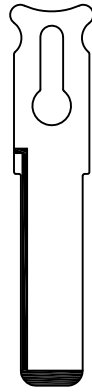

HU-HAAC5

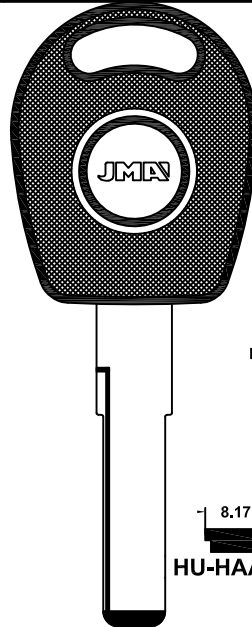

LAT.

HU-HAA.P1

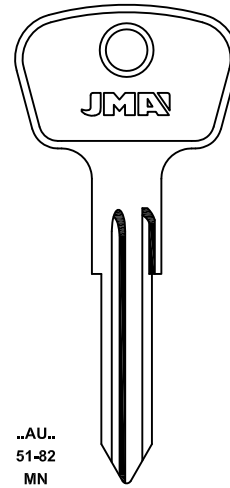

..AU..  
51-82  
MN  
0001-1000  
HU-MN

MAN

# HUF

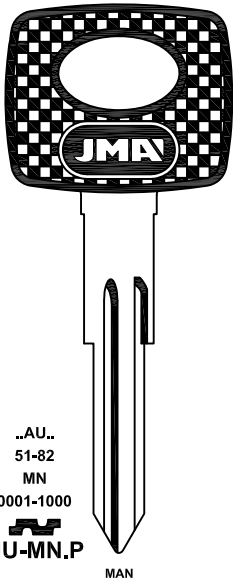

..AU..  
51-82  
MN  
0001-1000  
HU-MN.P

MAN

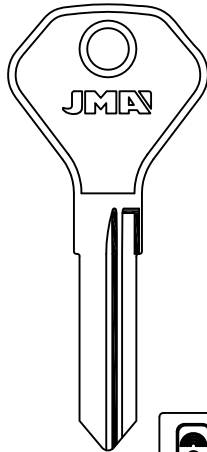

NW...  
1-51

HU-NW

BOSCH

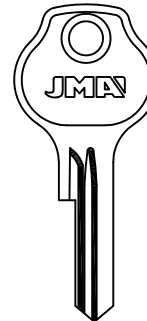

P  
001-252  
HU-P

VDO

# HUF

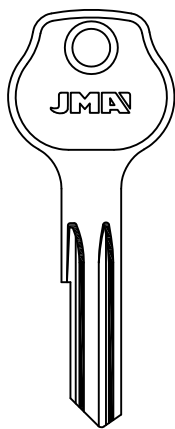

SE  
001-750  
SC  
401-630

HU-SC

BMW-MAN-PORSCHE-STEYR PUCH-VOLKSWAGEN-SCANIA  
AKS

SR  
001-240  
KSR  
001-240  
LSR  
001-240  
TSR  
001-240  
HU-SR



SZ  
1-240  
HU-SZ

SU  
001-240  
401-630  
HU-SU

SX  
001-240  
HU-SX

SY  
001-240  
HU-SY

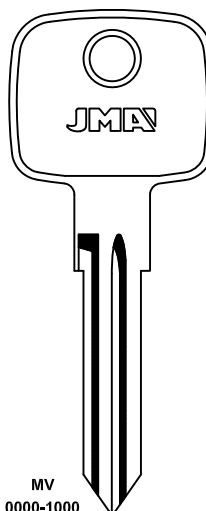

MV  
0000-1000  
ME-1

MERCEDES  
CLAUSOR

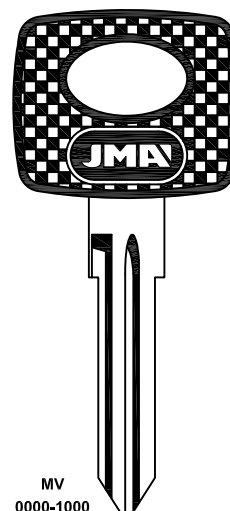

MV  
0000-1000  
ME-1.P

MERCEDES  
CLAUSOR



PARA-FOR:

HUF (D)

HUF

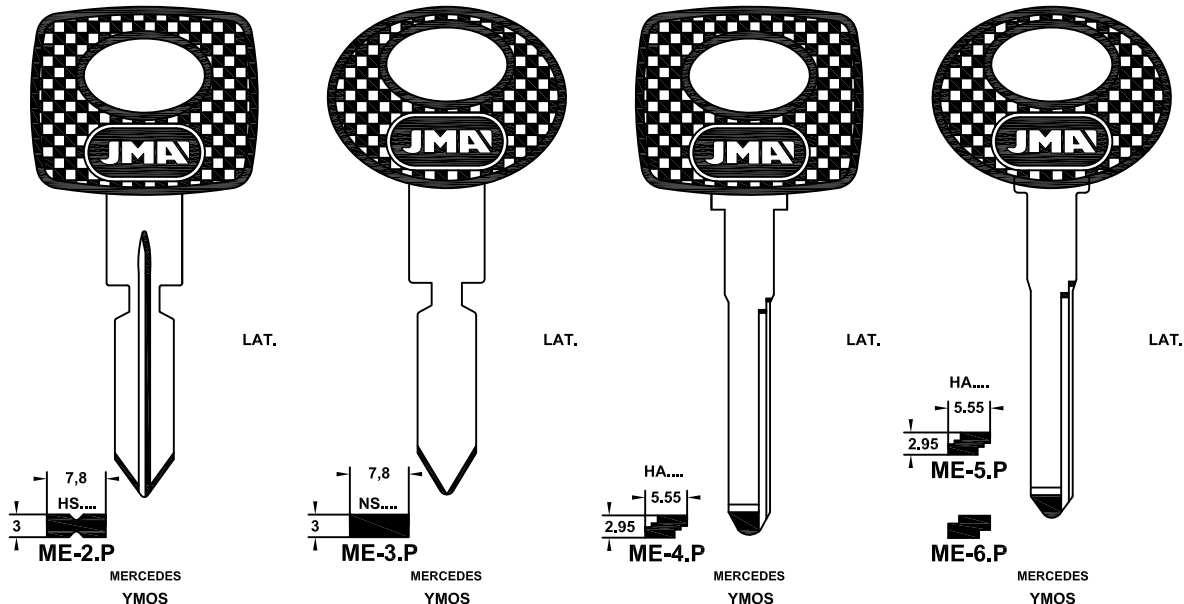

HUF

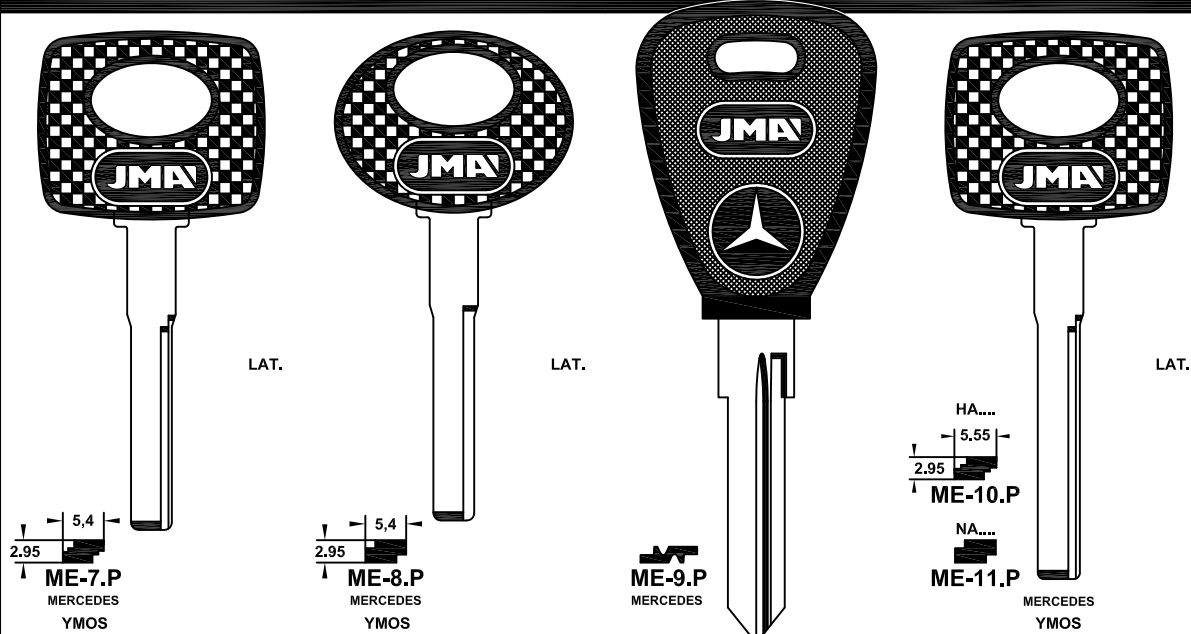

HUF

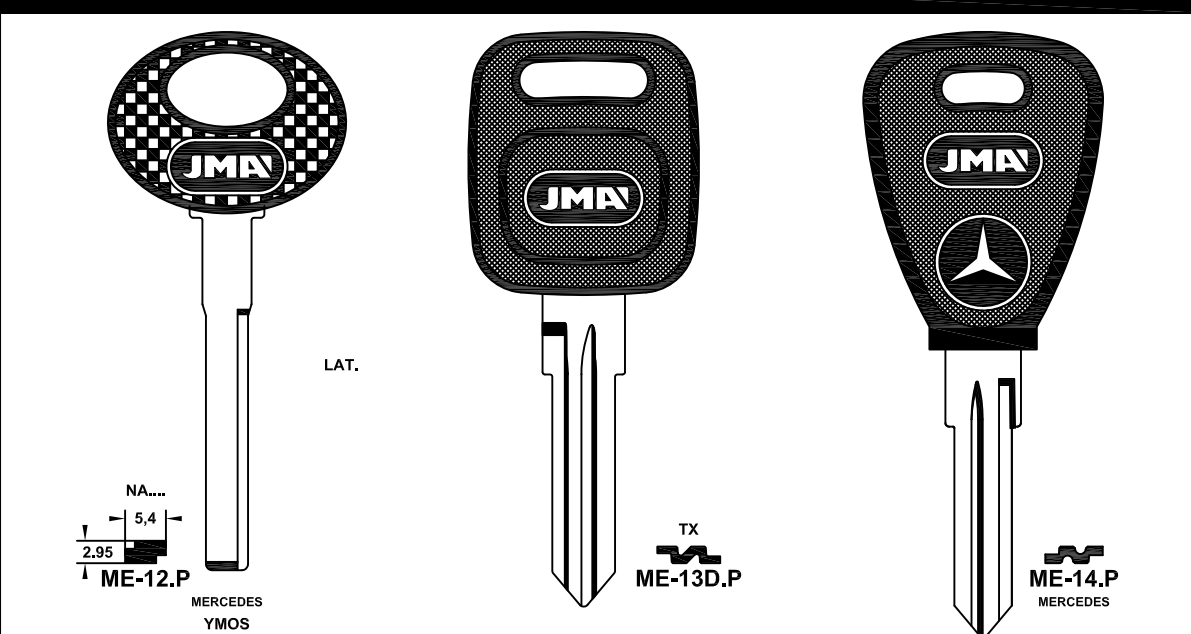

# HUF

PARA-FOR:

HUF (D)

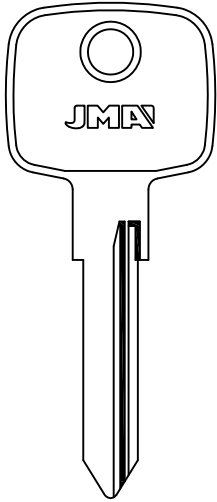

HD 4001-7350  
 NZ 0001-1400  
 NZ 2001-2500  
 NZ 1-99/1-99

**ME-HD**

HZ 0001-1400  
 HZ 2001-3500  
 HZ 4001-5000  
 ND  
 4001-5795  
 5801-7350  
 HZ 1-99/1-99

**ME-HZ**  
 MERCEDES-STEYR PUCH  
 YMOS

..HF..  
 1-99/1-99

HF 0001-1200  
 NM....  
 0001-1200  
 4001-7350

**ME-HF**

HM 0001-1200  
 2501-3500  
 4001-5795  
 5801-7350  
 NF 0001-1200  
 ..NF..  
 1-99/1-99

**ME-HM**

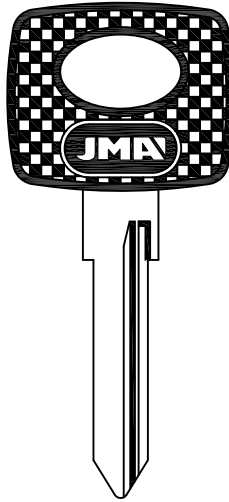

HD 4001-7350  
 NZ 0001-1400  
 NZ 2001-2500  
 NZ 1-99/1-99

**ME-HD.P**

HZ 0001-1400  
 HZ 2001-3500  
 HZ 4001-5000  
 ND  
 4001-5795  
 5801-7350  
 HZ 1-99/1-99

**ME-HZ.P**  
 MERCEDES-STEYR PUCH  
 YMOS

..HF..  
 1-99/1-99

HF 0001-1200  
 NM....  
 0001-1200  
 4001-7350

**ME-HF.P**

HM 0001-1200  
 2501-3500  
 4001-5795  
 5801-7350  
 NF 0001-1200  
 ..NF..  
 1-99/1-99

**ME-HM.P**

# HUF

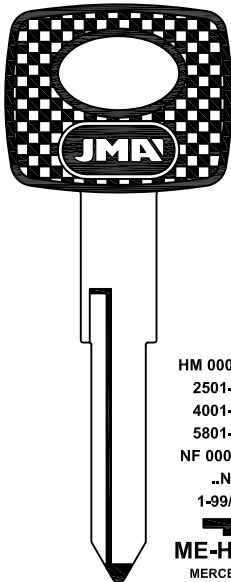

HM 0001-1200  
 2501-3500  
 4001-5795  
 5801-7350  
 NF 0001-1200  
 ..NF..  
 1-99/1-99

**ME-HML.P**  
 MERCEDES  
 YMOS

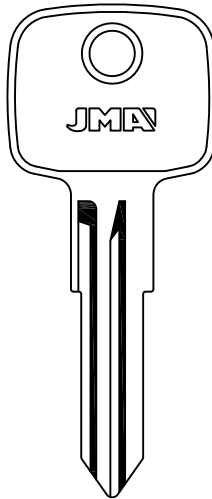

HU  
 6001-8130

**ME-HU**

NU  
 6001-8130

**ME-NU**  
 MERCEDES  
 YMOS

HY  
 6001-8130

**ME-HY**

NY  
 6001-8130

**ME-NY**

# HUF

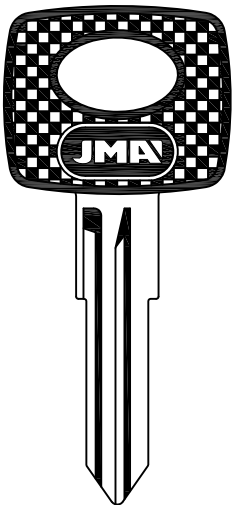

HU  
 6001-8130

**ME-HU.P**

NU  
 6001-8130

**ME-NU.P**  
 MERCEDES  
 YMOS

HY  
 6001-8130

**ME-HY.P**

NY  
 6001-8130

**ME-NY.P**

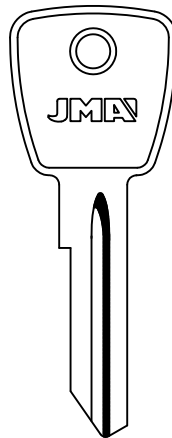

L  
 001-300

**ME-L**  
 MERCEDES  
 IMSA-YMOS

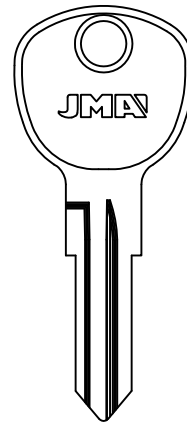

S  
 101-295  
 401-465  
 501-695

**ME-S**  
 MERCEDES  
 CASI



PARA-FOR:

HUF (D)

### HUF

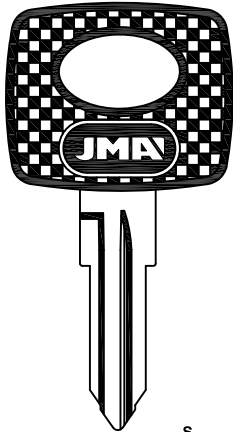
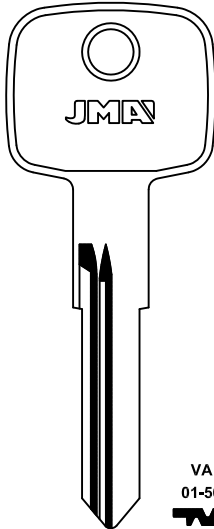
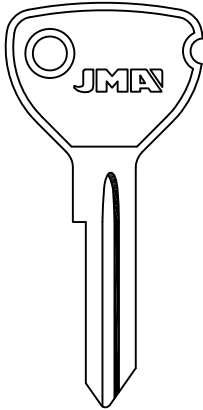
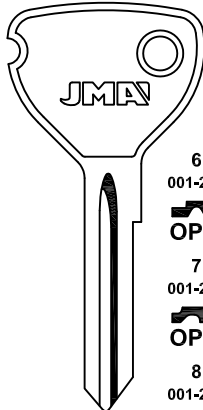
|   |   |   |  |
|---|---|---|--|
|  <p style="text-align: center;">S<br/>101-295<br/>401-465<br/>501-695</p> <p style="text-align: center;"><b>ME-S.P</b><br/>MERCEDES<br/>CASI</p> |  <p style="text-align: center;">VA<br/>01-50</p> <p style="text-align: center;"><b>ME-VA</b><br/>HANOMAG-MERCEDES<br/>CASI</p> |  <p style="text-align: center;"><b>OP-1</b></p> |  <p style="text-align: center;">6<br/>001-250<br/><b>OP-6</b><br/>7<br/>001-250<br/><b>OP-7</b><br/>8<br/>001-250<br/><b>OP-8</b><br/>9<br/>001-250<br/><b>OP-9</b></p> <p style="text-align: center;"><b>DAEWOO-OPEL-VAUXHALL</b><br/>YMOS</p> |
|---|---|---|--|

### HUF

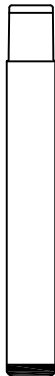
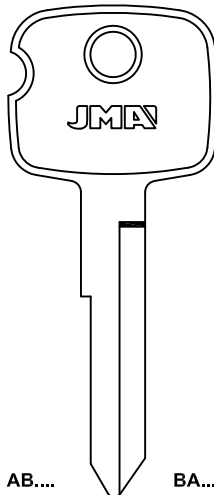
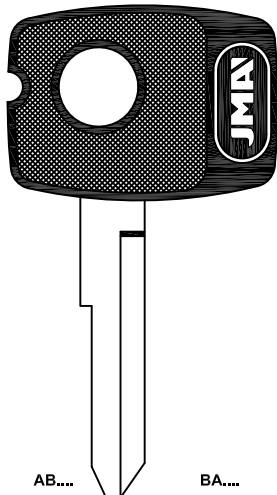
|  |   |  |
|--|---|--|
|  <p style="text-align: center;">ALP.</p> <p style="text-align: center;">Z...1-2000<br/>Z...2001-4000<br/>Z...4001-6000</p> <p style="text-align: center;"><b>OP-11C1</b></p> |  <p style="text-align: center;">AB...<br/>1-1000<br/><b>OP-AB</b><br/>DAEWOO-HOLDEN-OPEL-VAUXHALL<br/>YMOS</p> <p style="text-align: center;">BA...<br/>1-1000<br/><b>OP-BA</b><br/>DAEWOO-HOLDEN-OPEL-VAUXHALL<br/>YMOS</p> |  <p style="text-align: center;">AB...<br/>1-1000<br/><b>OP-AB.P</b><br/>DAEWOO-HOLDEN-OPEL-VAUXHALL<br/>YMOS</p> <p style="text-align: center;">BA...<br/>1-1000<br/><b>OP-BA.P</b><br/>DAEWOO-HOLDEN-OPEL-VAUXHALL<br/>YMOS</p> |
|--|---|--|

### HUF

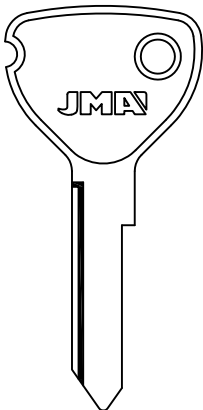
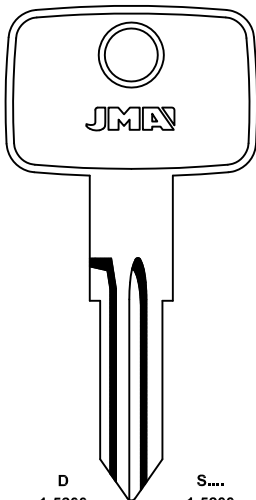
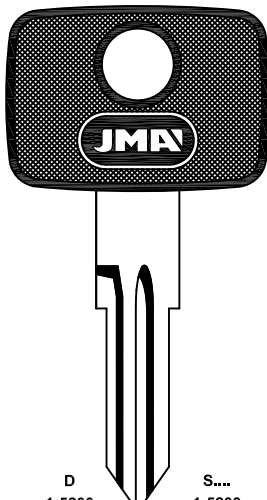
|   |  |   |
|---|--|---|
|  <p style="text-align: center;">B...1-380<br/>BB...501-1000<br/>BB...1751-2000<br/>BB...2501-3000</p> <p style="text-align: center;"><b>OP-BB</b><br/>DAEWOO-OPEL-VAUXHALL</p>   | <p style="text-align: center;">CC...501-1000<br/>CC...1751-2000<br/>CC...2501-3000</p> <p style="text-align: center;"><b>OP-CC</b></p> <p style="text-align: center;">EE...501-1000<br/>EE...1751-2000<br/>EE...2501-3000</p> <p style="text-align: center;"><b>OP-EE</b><br/>DAEWOO-OPEL-VAUXHALL</p>             | <p style="text-align: center;">DD...501-1000<br/>DD...1751-2000<br/>DD...2501-3000</p> <p style="text-align: center;"><b>OP-DD</b></p> <p style="text-align: center;">FF...501-1000<br/>FF...1751-2000<br/>FF...2501-3000</p> <p style="text-align: center;"><b>OP-FF</b></p> |
|  <p style="text-align: center;">D<br/>1-5200<br/><b>OP-D</b><br/>DAEWOO-GM-LOTUS-OPEL-VAUXHALL<br/>YMOS</p> <p style="text-align: center;">S...<br/>1-5200<br/><b>OP-S</b><br/>DAEWOO-GM-LOTUS-OPEL-VAUXHALL<br/>YMOS</p> |  <p style="text-align: center;">D<br/>1-5200<br/><b>OP-D.P</b><br/>DAEWOO-GM-LOTUS-OPEL-VAUXHALL<br/>YMOS</p> <p style="text-align: center;">S...<br/>1-5200<br/><b>OP-S.P</b><br/>DAEWOO-GM-LOTUS-OPEL-VAUXHALL<br/>YMOS</p> |   |











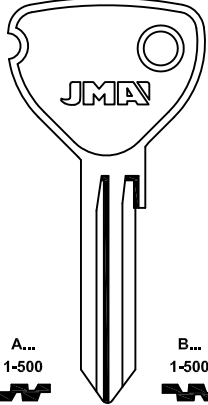
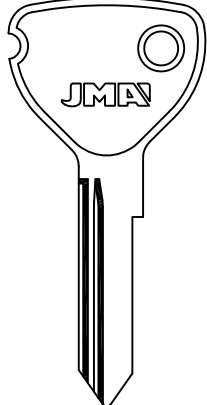
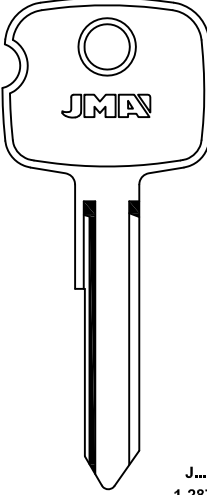
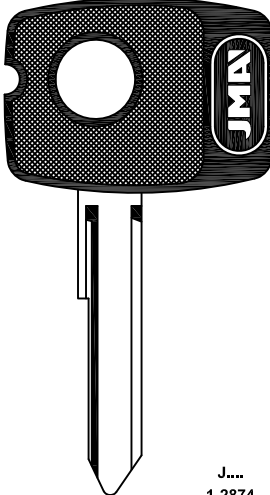





# HUF

PARA-FOR:



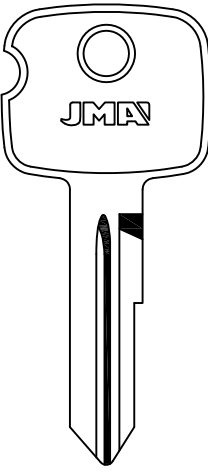
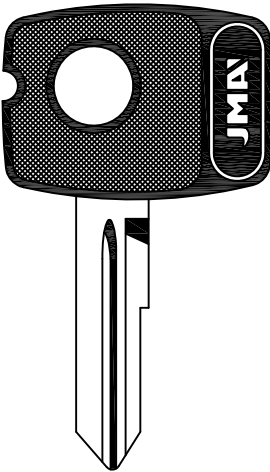
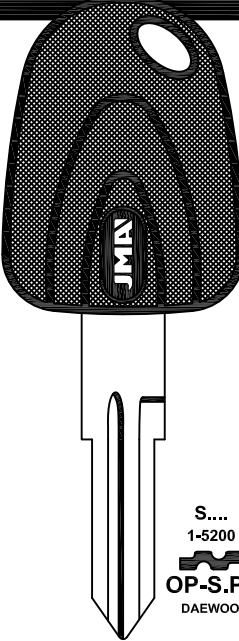
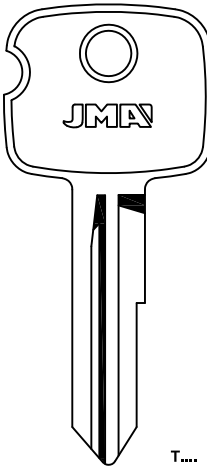

HUF (D)

|   |  |   |   |
|---|--|---|---|
|   |   |    |   |
| A...<br>1-500<br><br>OP-HA                          | B...<br>1-500<br><br>OP-HB                          | J...<br>1-2874<br><br>OP-J                                       | J...<br>1-2874<br><br>OP-J.P                                   |
| A...<br>1-500<br><br>OP-NA<br>OPEL-VAUXHALL<br>YMOS | B...<br>1-500<br><br>OP-NB<br>OPEL-VAUXHALL<br>YMOS | G...1-250<br>G...1251-1500<br><br>OP-HG<br>OPEL-VAUXHALL<br>YMOS | H...1-250<br>H...1251-1500<br><br>OP-HH<br>OPEL-VAUXHALL<br>YMOS |
|   |  | DAEWOO-HOLDEN-OPEL-VAUXHALL<br>YMOS   | DAEWOO-HOLDEN-OPEL-VAUXHALL<br>YMOS   |

# HUF

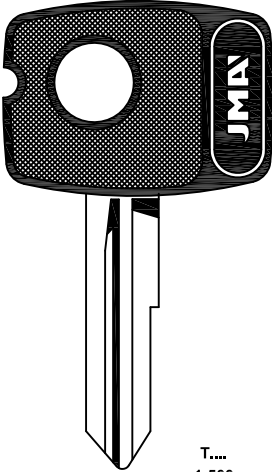
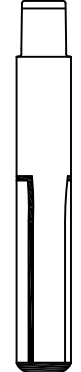
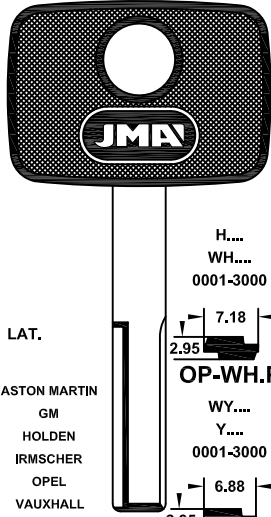
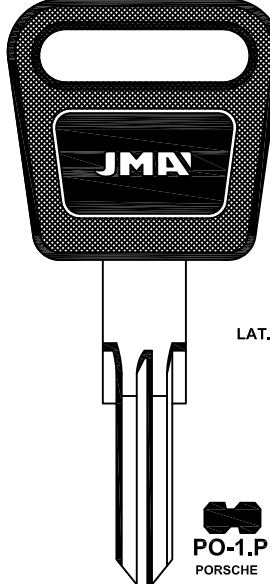
|  |  |  |   |
|--|--|--|---|
|   |    |    |   |
| R...<br>1-1500<br><br>OP-R<br>GM-IRMSCHER-OPEL-VAUXHALL<br>YMOS | R...<br>1-1500<br><br>OP-R.P<br>GM-IRMSCHER-OPEL-VAUXHALL<br>YMOS | S...<br>1-5200<br><br>OP-S.P1<br>DAEWOO | T...<br>1-500<br>501-1500<br><br>OP-T<br>GM-IRMSCHER-OPEL-VAUXHALL<br>YMOS |

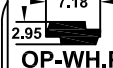
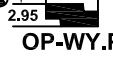
# HUF

|   |  |  |  |
|---|--|--|--|
|   |   |   |                                |
| T...<br>1-500<br>501-1500<br><br>OP-T.P<br>GM-IRMSCHER-OPEL-VAUXHALL<br>YMOS | H...<br>WH...<br>0001-3000<br><br>OP-WHC1 | H...<br>WH...<br>0001-3000<br>7.18<br>2.95<br><br>OP-WH.P<br>WY...<br>Y...<br>0001-3000<br>6.88<br>2.95<br><br>OP-WY.P<br>YMOS | LAT.<br><br>PO-1.P<br>PORSCHE |
| ALP. LAT.<br>ASTON MARTIN<br>GM<br>HOLDEN<br>IRMSCHER<br>OPEL<br>VAUXHALL   |  |  |  |



PARA-FOR:

HUF (D)

HUF

36,5 mm.

LAT.

PO-2.P  
PORSCHÉ

HC....  
0001-2080  
PO-HC  
NC....  
0001-2080  
PO-NC  
PORSCHÉ  
DOM

HC....  
0001-2080  
PO-HC.P  
NC....  
0001-2080  
PO-NC.P  
PORSCHÉ  
DOM

AKS  
CASI  
NEIMAN  
UBE  
WITTE  
YMOS

AH....  
1-8154  
1001-9282  
SE-AH.P  
SEAT

HUF

...124-197  
...501-598  
...701-790  
...G06-G10  
...0G1-1G0  
A...101-125  
A...701-790  
G...001-100

SE-AN  
SEAT

VO-1  
FIAT IVECO  
NEIMAN

AH....  
1-8154  
1001-9282  
VO-2  
VOLKSWAGEN  
AKS-CASI-UBE-WITTE

AH....  
1-8154  
1001-9282  
VO-2.P  
2FF  
VO-8.P  
VOLKSWAGEN  
AKS-CASI-UBE-WITTE

VO-2D.P

HUF

AH....  
1-8154  
1001-9282  
VO-2.P1  
2FF  
VO-8.P1  
VOLKSWAGEN BRASIL

VO-2D.P1

AN  
001-854  
1001-1918  
2001-2830  
3001-3890  
4001-5151  
6001-7086  
7001-8154  
8201-9282  
VO-5.P  
CASI-HUF-UBE-WITTE

VO-6D



# HUF

PARA-FOR:

HUF (D)

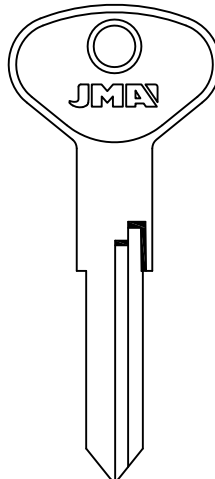

AH...  
1-8154  
1001-9282

 VO-AH

HV...  
1-8154  
1001-9282

 VO-HV

VB-NV-MD...  
1-8154  
1001-9282

 VO-VB

N...  
 VO-N



AN...  
001-854  
1001-1918  
2001-2830  
3001-3890  
4001-5151  
6001-7086  
7001-8154  
8201-9282

 AU-AN

AUDI-FORD-PORSCHE-VOLKSWAGEN  
AKS-CASI-LUBE-WITTE

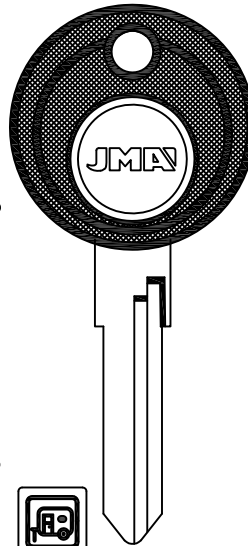

AH...  
1-8154  
1001-9282

 VO-AH.P

HV...  
1-8154  
1001-9282

 VO-HV.P

VB-NV-MD...  
1-8154  
1001-9282

 VO-VB.P

N...  
 VO-N.P





AN...  
001-854  
1001-1918  
2001-2830  
3001-3890  
4001-5151  
6001-7086  
7001-8154  
8201-9282

 AU-AN.P

AUDI-FORD-PORSCHE-VOLKSWAGEN  
AKS-CASI-LUBE-WITTE

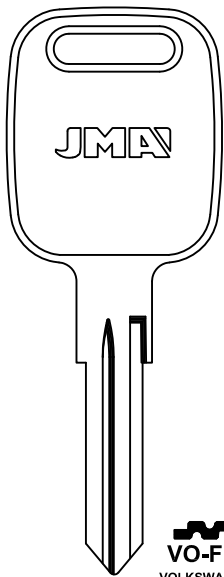
# HUF



 VO-FH

VOLKSWAGEN

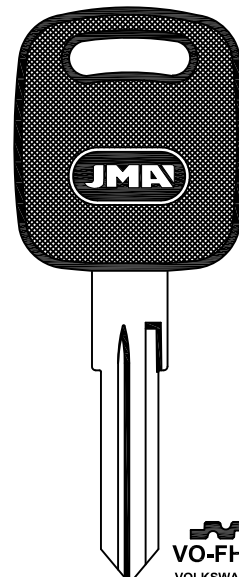

 VO-FH.P

VOLKSWAGEN

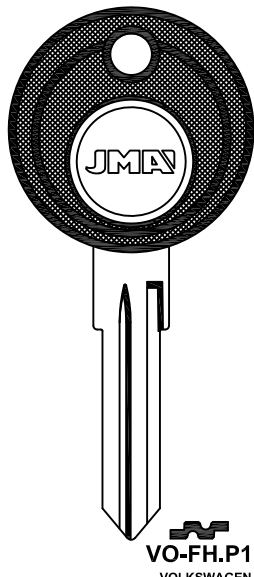

 VO-FH.P1

VOLKSWAGEN

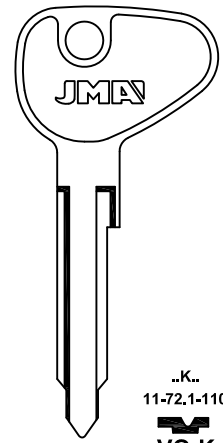

..K...  
11-72.1-110

 VO-K

..L...  
11-72.1-110

 VO-L

VOLKSWAGEN  
NEIMAN-WITTE

# HUF

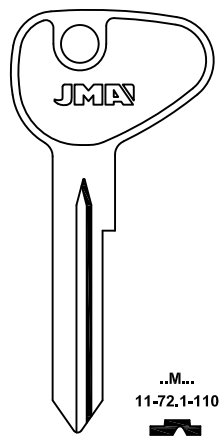

..M...  
11-72.1-110

 VO-M



..R...  
11-72.1-110

 VO-R

MAN-VOLKSWAGEN  
AKS-CASI-WITTE

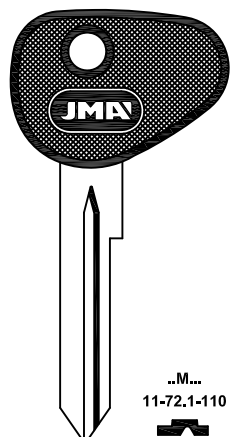

..M...  
11-72.1-110

 VO-M.P

..R...  
11-72.1-110

 VO-R.P

MAN-VOLKSWAGEN  
AKS-CASI-WITTE

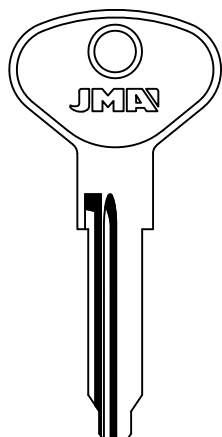

..VA...  
01-55

 VO-VA

VOLKSWAGEN

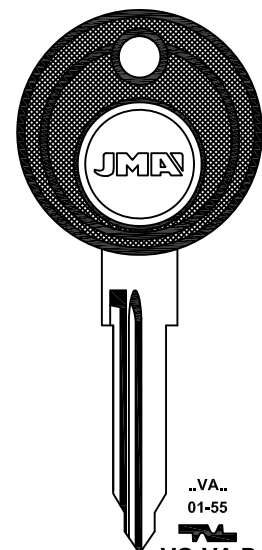

..VA...  
01-55

 VO-VA.P

VOLKSWAGEN









**PARA-FOR:**

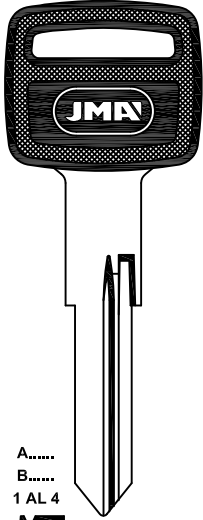
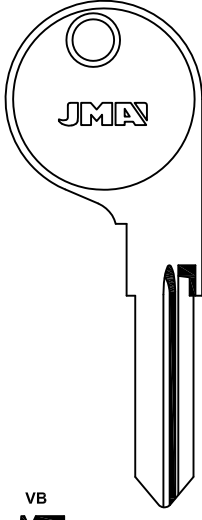
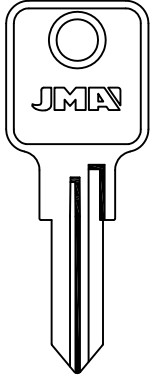
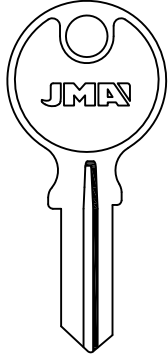





HUF (D)

HUWIL (D)

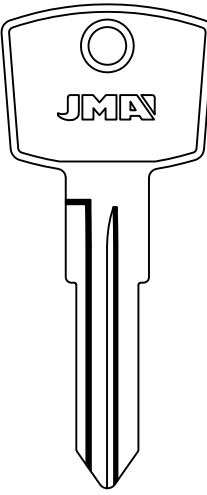
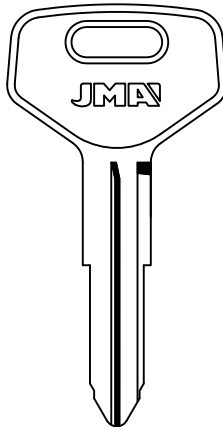
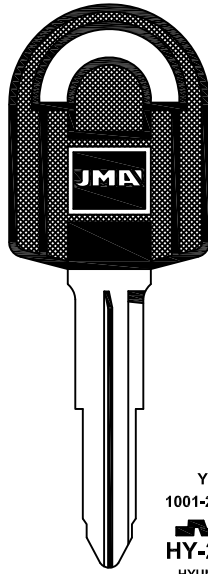
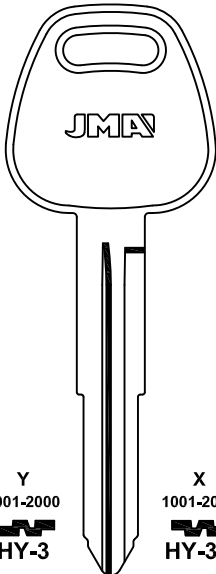





HYUNDAI (K)

| HUF   |   | HUWIL   |  |
|---|---|---|--|
|    |                  |    |   |
| A.....<br>B.....<br>1 AL 4<br><br>VO-VB.P1<br>NEIMAN | VB<br><br>VW-K70 | W<br>3000-4000<br>A<br>3001-4000<br> HUF-1<br> HUW-1D<br>STRAFOR-STEELCASE | N<br>0005-1878<br>N<br>2001-2204<br> HUW-N<br>TECNO |

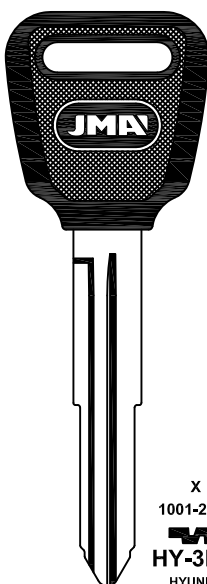
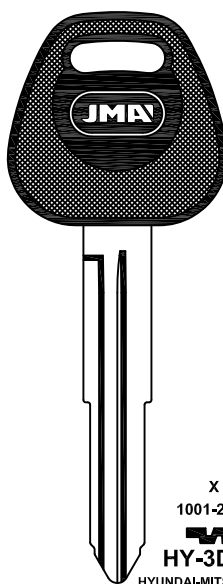
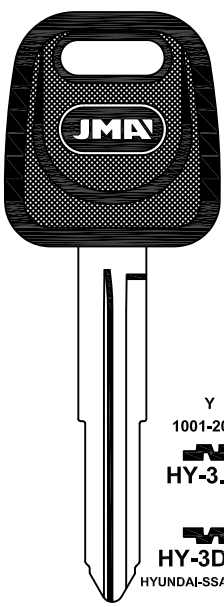
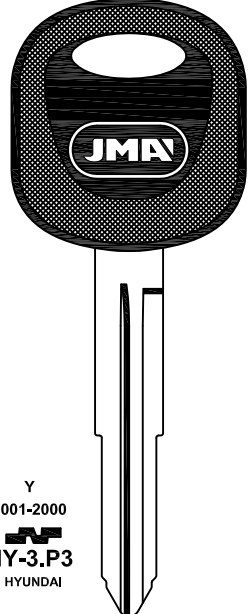
**HYUNDAI**

|   |  |  |  |
|---|--|--|--|
|   |                                        |   |    |
| A/Z.... 0111-0333<br><br>HY-1<br>HYUNDAI | Y<br>1001-2000<br><br>HY-2<br>HYUNDAI | Y<br>1001-2000<br><br>HY-2.P<br>HYUNDAI | Y<br>1001-2000<br> HY-3<br>HYUNDAI-MITSUBISHI<br>X<br>1001-2000<br><br>HY-3D<br>HYUNDAI-MITSUBISHI |

**HYUNDAI**

|   |   |  |   |
|---|---|--|---|
|    |    |    |    |
| X<br>1001-2000<br><br>HY-3D.P<br>HYUNDAI | X<br>1001-2000<br><br>HY-3D.P1<br>HYUNDAI-MITSUBISHI | Y<br>1001-2000<br><br>HY-3.P2<br><br>HY-3D.P2<br>HYUNDAI-SSANGYONG | Y<br>1001-2000<br><br>HY-3.P3<br>HYUNDAI |



HYUNDAI

PARA-FOR:  
HYUNDAI (K)

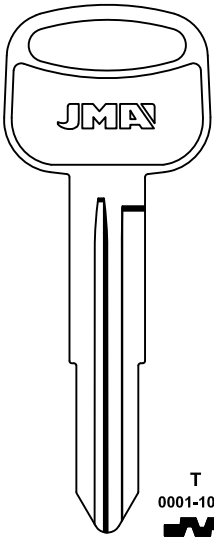

T  
0001-1000  
HY-4  
HYUNDAI

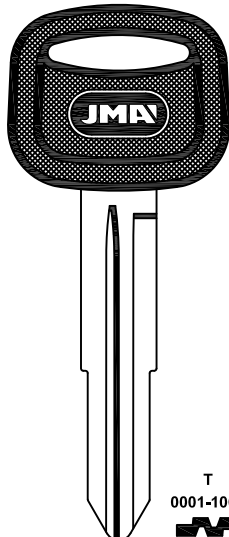

T  
0001-1000  
HY-4.P  
HYUNDAI

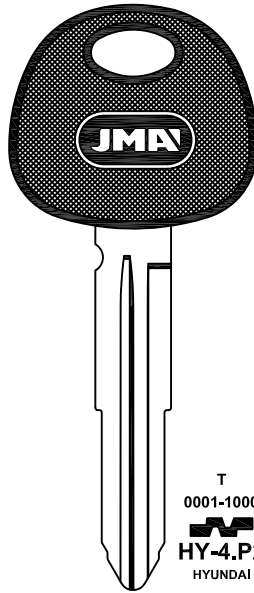

T  
0001-1000  
HY-4.P2  
HYUNDAI

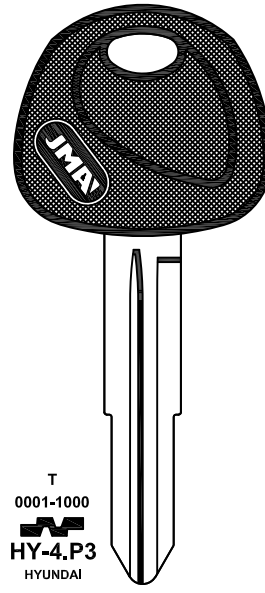

T  
0001-1000  
HY-4.P3  
HYUNDAI

HYUNDAI

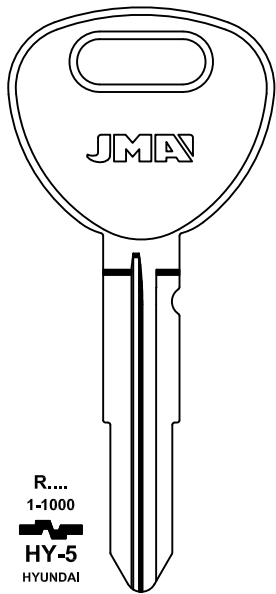

R...  
1-1000  
HY-5  
HYUNDAI

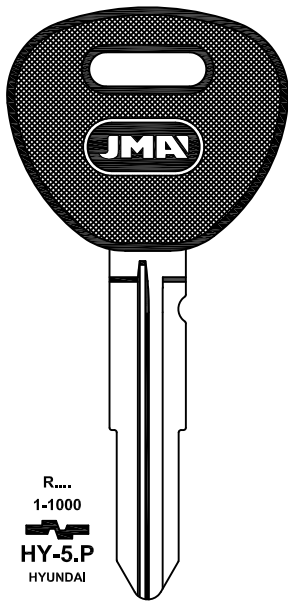

R...  
1-1000  
HY-5.P  
HYUNDAI

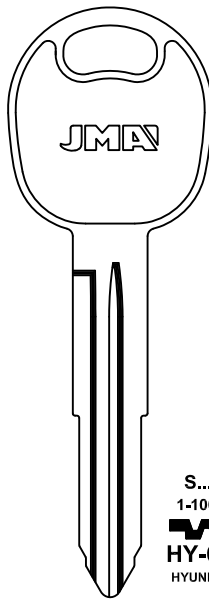

S...  
1-1000  
HY-6D  
HYUNDAI

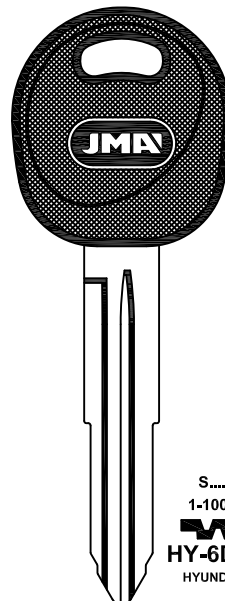

S...  
1-1000  
HY-6D.P  
HYUNDAI

HYUNDAI

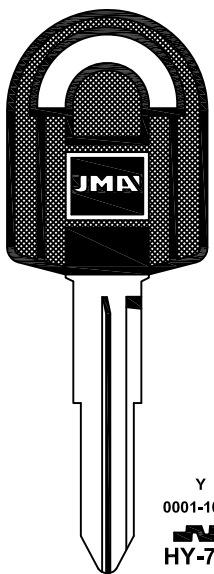

Y  
0001-1000  
HY-7.P  
HYUNDAI

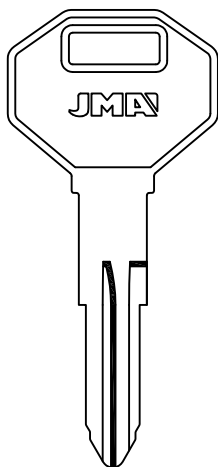

H  
1-2000  
HY-8  
HYUNDAI

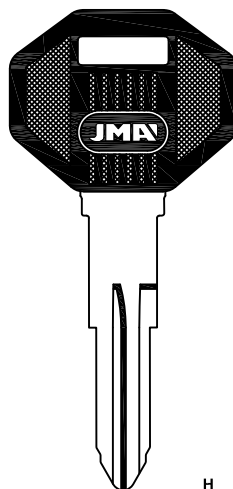

H  
1-2000  
HY-8.P  
HYUNDAI

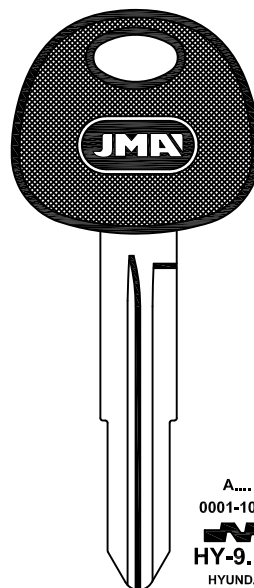

A...  
0001-1000  
HY-9.P2  
HYUNDAI



**PARA-FOR:**

HYUNDAI (K)

IMSA (E)

**HYUNDAI**

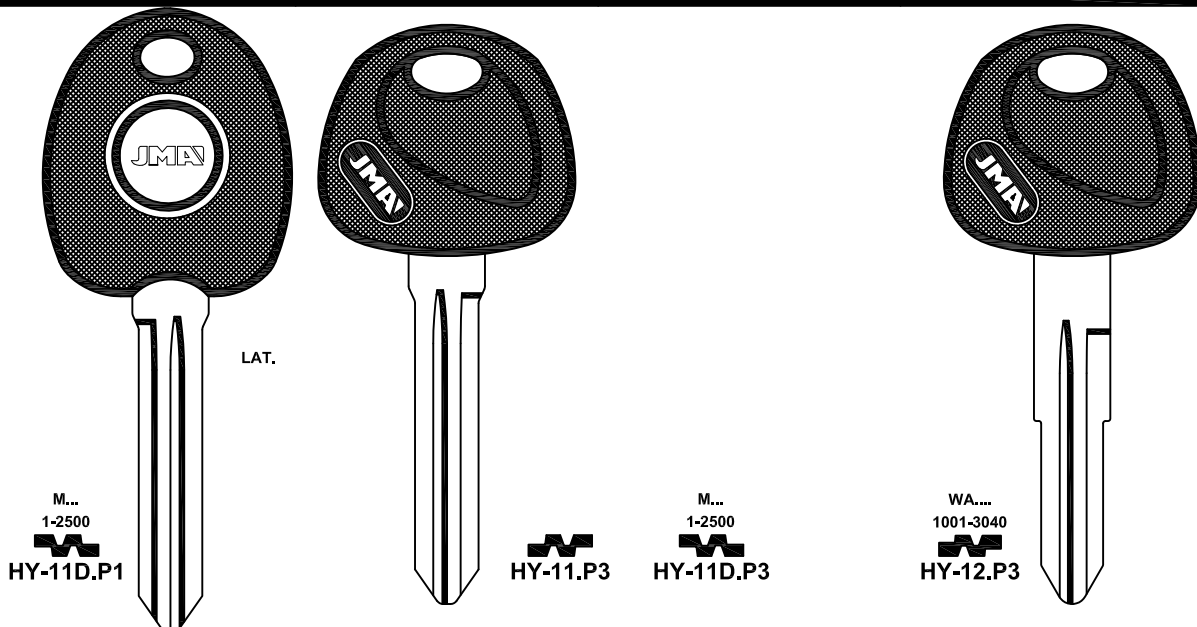

LAT.

M...  
1-2500  
HY-11D.P1

M...  
1-2500  
HY-11.P3

WA....  
1001-3040  
HY-12.P3

**IMSA**

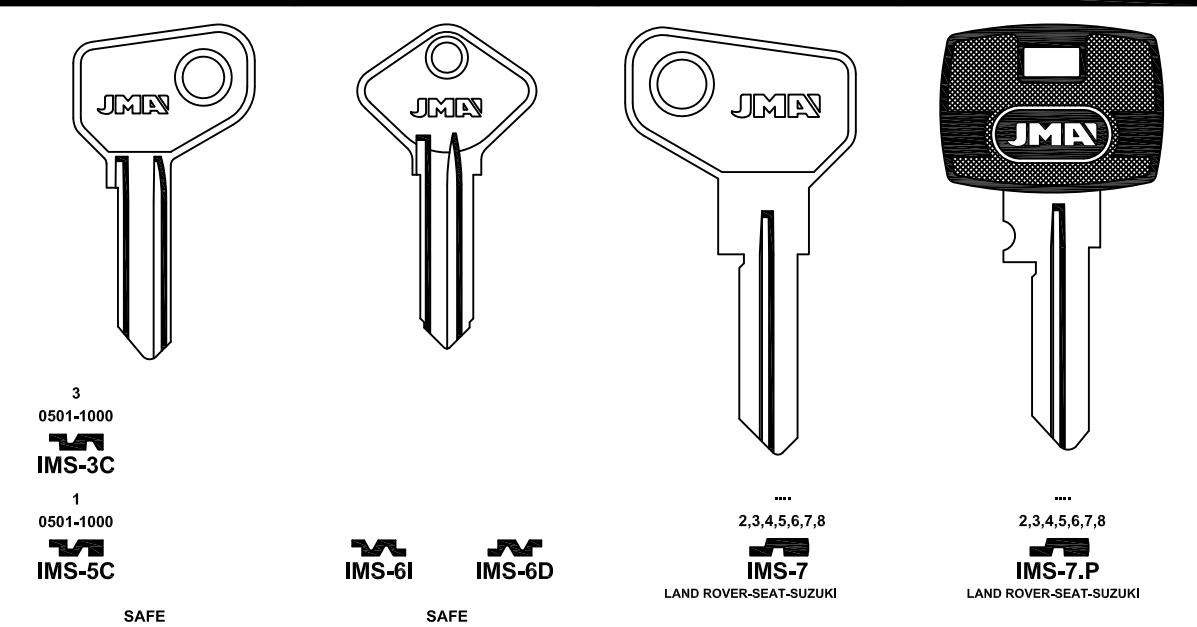

3  
0501-1000  
IMS-3C

1  
0501-1000  
IMS-5C

IMS-6I

IMS-6D

2,3,4,5,6,7,8  
IMS-7  
LAND ROVER-SEAT-SUZUKI

2,3,4,5,6,7,8  
IMS-7.P  
LAND ROVER-SEAT-SUZUKI

SAFE

SAFE

**IMSA**

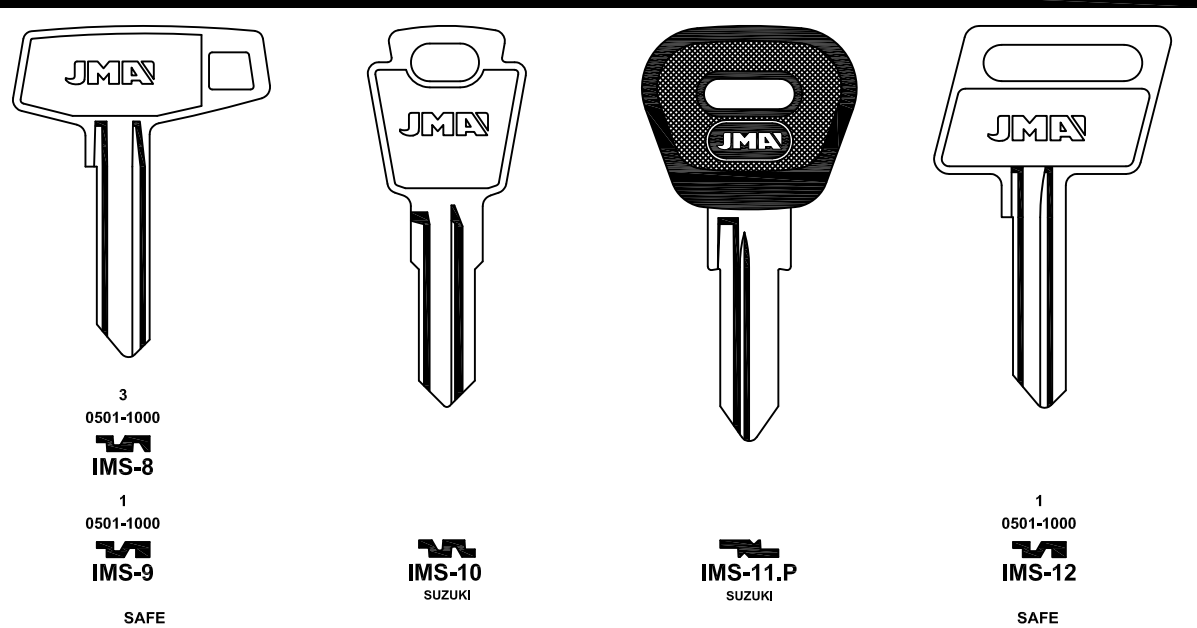

3  
0501-1000  
IMS-8

1  
0501-1000  
IMS-9

IMS-11.P  
SUZUKI

IMS-11.P  
SUZUKI

1  
0501-1000  
IMS-12

SAFE

SAFE

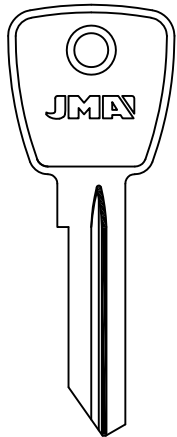

**IMSA**L  
001-300

IMS-MER

SAFE

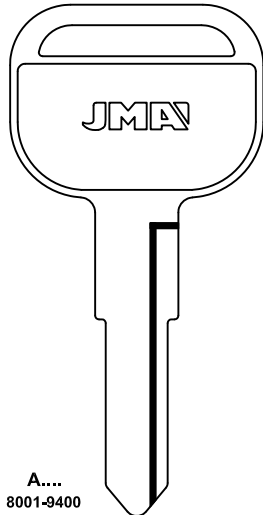
**ISUZU**A....  
8001-9400

ISU-1

ISUZU

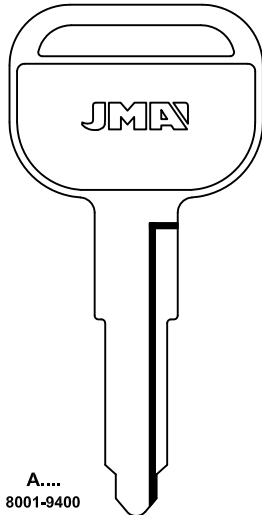
A....  
8001-9400

ISU-2

ISUZU

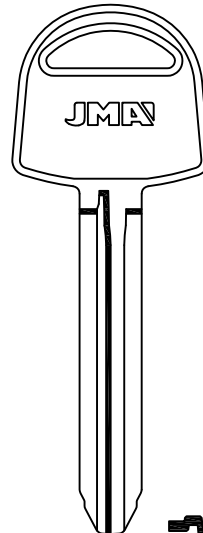

ISU-3D

**PARA-FOR:**

IMSA (E)

ISUZU (J)

JOHN DEERE  
(USA)

KAMAZ (RUS)

KAWASAKI (J)

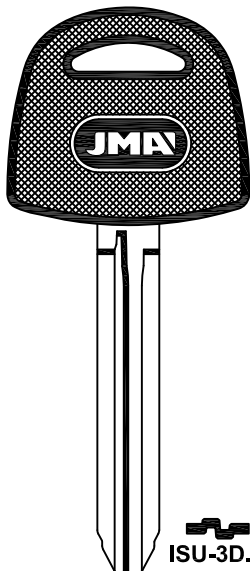
**ISUZU**

ISU-3D.P

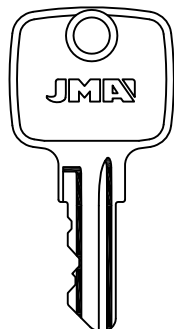
**JOHN DEERE**

LAT.



JD-1

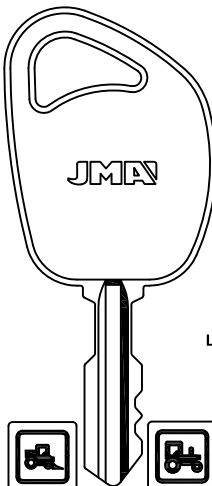

LAT.



JD-2

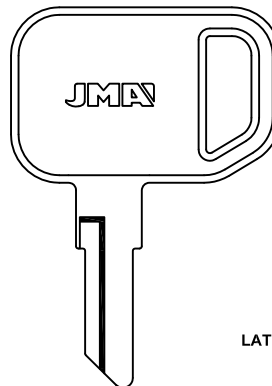

LAT.

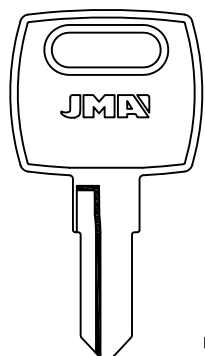

JD-3D

**JOHN DEERE**

LAT.

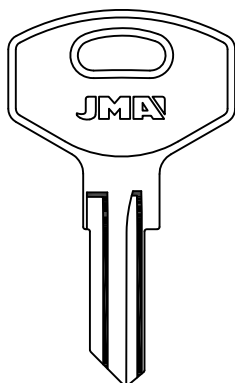

JD-4D

**KAMAZ**

KAM-1

KAM-1D

ZIL

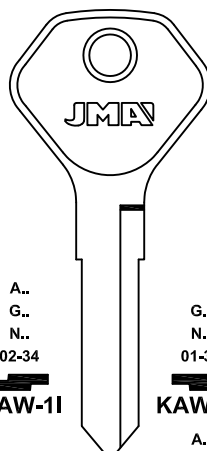
**KAWASAKI**A..  
G..  
N..  
02-34

KAW-1I

B....  
1 AL 4

KAW-2I

KAWASAKI

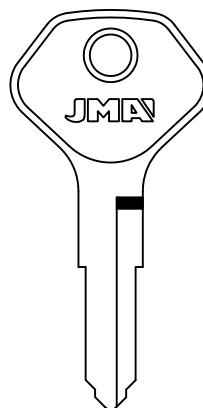
G..  
N..  
01-35

KAW-1D

A..  
G..  
N..  
1 AL 4

KAW-2D

Z  
5000-6000

KAW-3

KAWASAKI

**JMA**<sup>®</sup>

Copyright by Alejandro Altuna S.A. 2014



ATENCIÓN: Concerniente a las marcas y denominaciones comerciales ver nota en índice.  
 ATTENTION: Concerning the marks and commercial denominations see note in index.  
 ATTENTION: Concernant les marques et dénominations commerciales voir la note dans l'index.  
 ACHTUNG: Beziehen auf die marke und handelsname sehen sie die notiz im index.

**PARA-FOR:**

KAWASAKI (J)

KENWORTH  
(USA)

KIA (K)

**KAWASAKI**

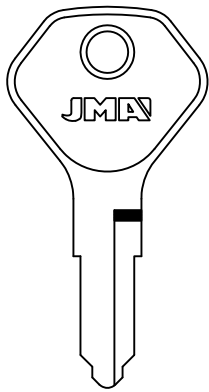

751-795  
PLC  
401-600  
  
**KAW-4**  
HYUNDAI-KAWASAKI

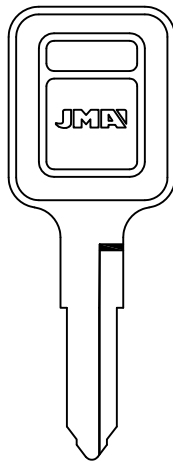

Z....  
5000-6000  
  
**KAW-5**  
KAWASAKI

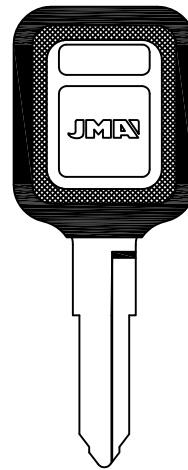

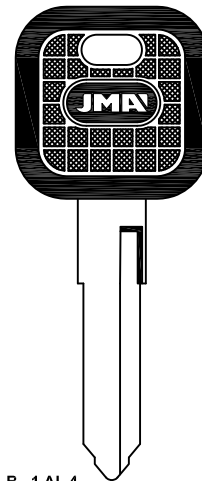

Z....  
5000-6000  
  
**KAW-5.P**  
KAWASAKI

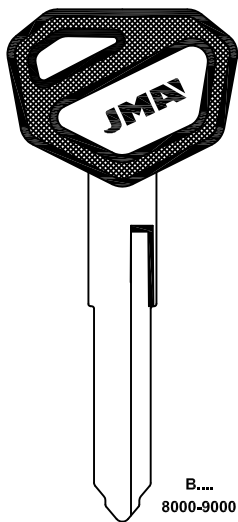

B.. 1 AL 4  
H.. 1 AL 4  
  
**KAW-6.P** **KAW-6D.P**  
CAGIVA-DUCATI-KAWASAKI

**KAWASAKI**



B....  
8000-9000  
  
**KAW-7.P**  
KAWASAKI

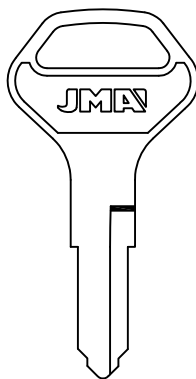

  
**KAW-8** **KAW-8D**

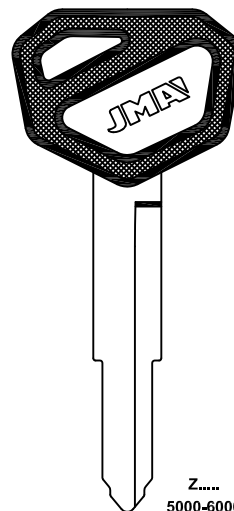

Z....  
5000-6000  
  
**KAW-9.P**  
KAWASAKI

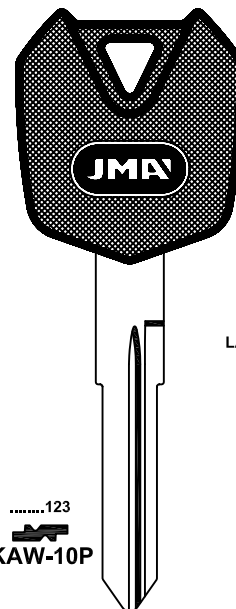

.....123  
  
**KAW-10P**

LAT.

**KENWORTH**

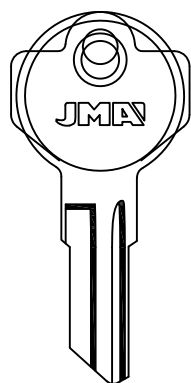

C....  
250-499  
1701-1950  
  
**KEN-1** **KEN-1D**  
BASCO

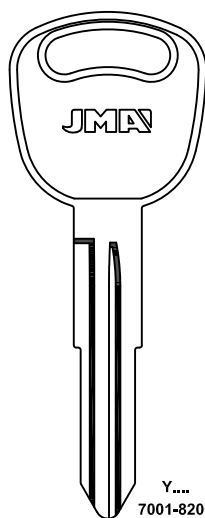

Y....  
7001-8200  
  
**KI-1D**  
FORD (AUSTRALIA)-KIA

**KIA**

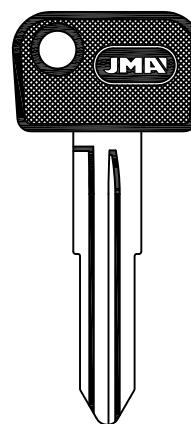

Y....  
7001-8200  
  
**KI-1D.P**

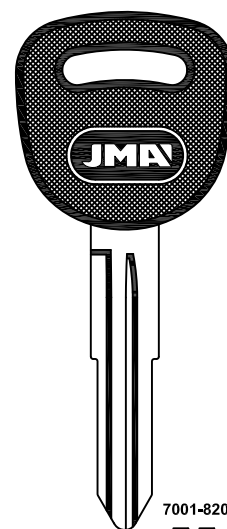

7001-8200  
  
**KI-1D.P1**  
FORD (AUSTRALIA)-KIA





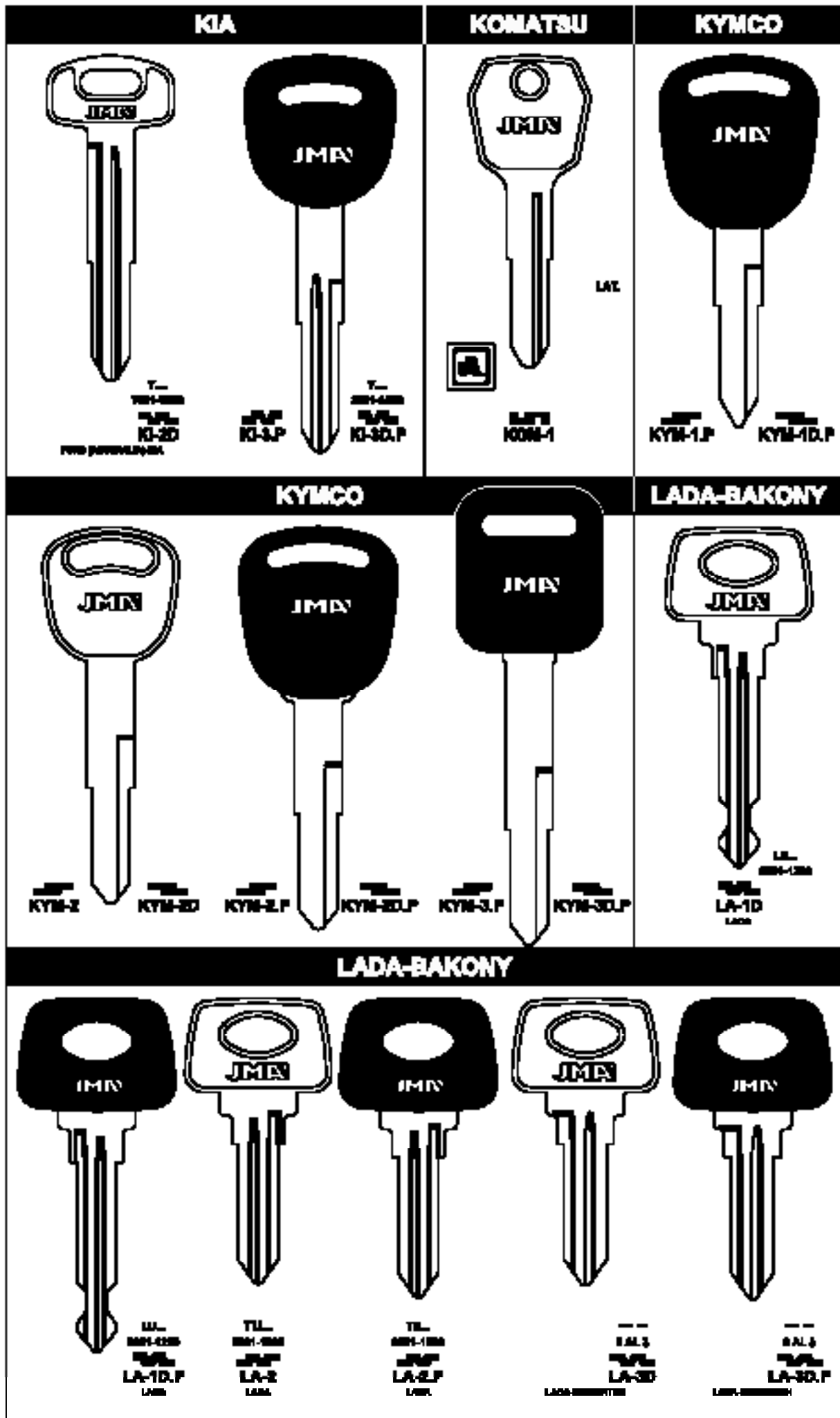

**PARA-FOR:**  
 KIA (K)  
 KOMATSU (USA)  
 KYMCO (K)  
 LADA-BAKONY (RUS)



**PARA-FOR:**

LADA-BAKONY  
(RUS)  
LAS (F)  
LMP (F)

| LADA-BAKONY                                |  | LAS   |   |
|--|--|---|---|
|  |  |   |   |
| LU...<br>0001-1280<br><b>LA-4D</b><br>LADA | LU...<br>0001-1280<br><b>LA-4D.P</b><br>LADA | AX<br>001-224<br><b>LAS-AX</b><br>EX<br><b>LAS-1D</b> | ABBS<br>ATAL<br>DUBOIS<br>ORDO<br>RENZ<br>STRAFOR<br>FH<br>001-400<br>501-550<br><b>LAS-FH</b><br>FM<br>001-400<br>501-550<br><b>LAS-4</b><br><b>LAS-4D</b> |
| ATAL-HÄFELE-KIFERM-RENZ                    |  |   |   |

| LAS  |   |   |   |
|--|---|---|---|
|  |   |   |   |
| FH<br>001-400<br>501-550<br><b>LAS-3</b><br>H<br><b>LAS-5</b><br>U<br><b>LAS-U</b> | E<br><b>LAS-5D</b><br>X<br><b>LAS-X</b> | TA<br><b>LAS-6</b><br>RM<br>0001-2000<br>KT<br>3001-4000<br><b>LAS-KT</b> | AT<br><b>LAS-6D</b><br>TK<br>4001-5000<br><b>LAS-TK</b> |
| KIFERM   |   | ATAL-KIFERM-MARCADET-RONIS  |   |
|  |   |   |   |
| BT<br>001-650<br><b>LAS-BT</b>   | TB<br>001-650<br><b>LAS-TB</b>          | CR<br>001-650<br><b>LAS-CR</b>  | RC<br>001-650<br><b>LAS-RC</b>                          |
| KIFERM-PJ  |   | P<br>001-224<br><b>LAS-P</b>  |   |

| LAS                          |  | LMP  |  |
|------------------------------|--|--|--|
|                              |  |  |  |
| R<br>001-224<br><b>LAS-R</b> | V<br>001-224<br><b>LAS-V</b><br>Y<br>001-224<br><b>LAS-Y</b> | XS<br>01-75<br><b>LAS-XS</b><br>SX<br>01-75<br><b>LAS-SX</b><br>TX<br>01-75<br><b>LAS-TX</b><br>XY<br>01-75<br><b>LAS-XY</b> | 10055-12538<br><b>LMP-1</b><br>EBRO-PEUGEOT-RENAULT<br>GELBON-ROS-SEIMA<br>10055-12538<br><b>LMP-1.P</b><br>EBRO-PEUGEOT-RENAULT<br>GELBON-ROS-SEIMA |
| DUBOIS-KIFERM-PJ-PK          |  | ATAL-JU-KIFERM-METEOR-RENZ   |  |



## LMP

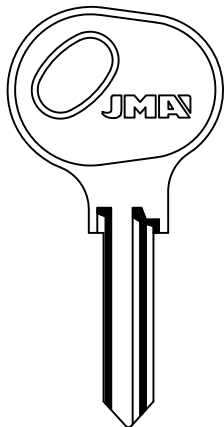

20000-25527  
50001-52500



**LMP-2**

PEUGEOT-RENAULT  
GELBON-SEIMA

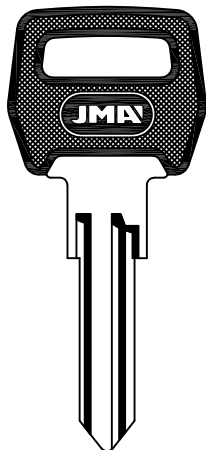

20000-25527  
50001-52500



**LMP-2.P**

PEUGEOT-RENAULT  
GELBON-SEIMA

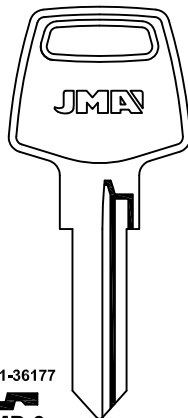

35001-36177



**LMP-3**

70001-72500  
75000-77500  
1AA-7FZ



**LMP-4**

PEUGEOT-RENAULT-TALBOT  
GELBON-SEIMA



**LMP-5**

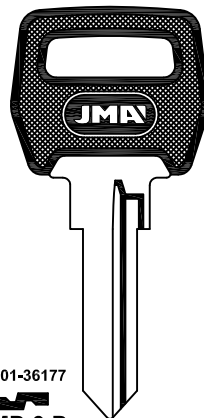

35001-36177



**LMP-3.P**

70001-72500  
75000-77500  
1AA-7FZ



**LMP-4.P**

PEUGEOT-RENAULT-TALBOT  
GELBON-SEIMA



**LMP-5.P**

## PARA-FOR:

LMP (F)

LOWE & FLETCHER

(GB)

## LMP

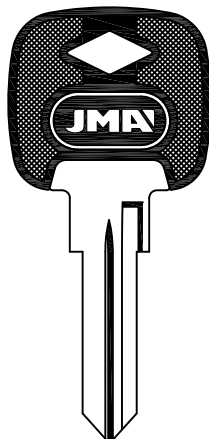

70001-72500  
75000-77500  
1AA-7FZ



**LMP-4.P1**



**LMP-5.P1**

RENAULT  
GELBON-SEIMA

## LOWE & FLETCHER

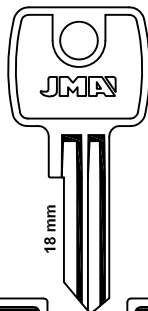

18 mm



90...1-200  
...1-400  
91...201-275  
GH...1-4000  
SS...1-400  
91...276-350



**LF-11**



**LF-1D**

CEM-EURO LOCKS-UNION

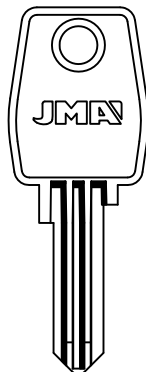

95001-97000  
97001-99000



**LF-2**



**LF-12**



**LF-12D**

BICICLETTA CYCLES  
DOBLE SAFE-EURO LOCKS

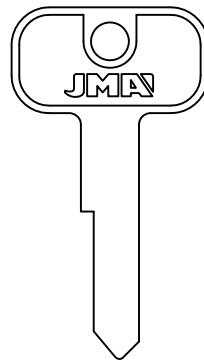

RL-RM  
801-952



**LF-3**

STREBOR

## LOWE & FLETCHER

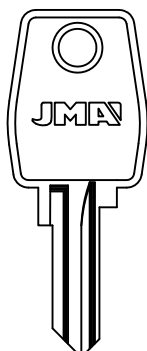

**LF-4I**

EURO LOCKS

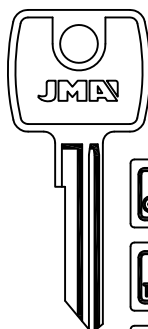

....  
70001-71000  
M....  
70001-71000



**LF-5**



**LF-5D**



**LF-32**

TELFORD

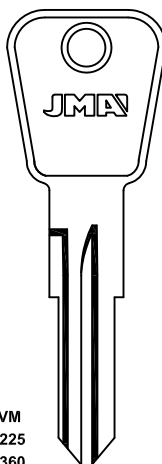

FV-VM  
101-225  
301-360  
VT...  
400-474



**LF-6**

CHRYSLER-VAUXHALL-BEDFORD-FORD

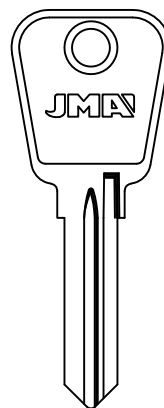

....  
66001-67200



**LF-7**

FORD EUROPA

....  
81001-87000



**LF-7D**



**PARA-FOR:**  
**LOWE & FLETCHER**  
 (GB)

**LOWE & FLETCHER**

93...201-400  
.....93901-94000

**LF-8**

**LF-8D**

93...401-900  
.....90901-90975

**LF-11**

**LF-11D**

**EURO LOCKS-MIBRA-UTZ**

15001-19000  
85001-87000

**LF-9**

**ROVER-BEDFORD  
BRITAX**

60... 001-200  
60... 001-200  
90... 001-200  
...1-400  
GHM...1-155  
M...1-400  
RV...1-400  
RVM...1-400  
SP...1-400  
99...1-400

**LF-15**

FFE  
001-100

**LF-17**

**CEM-EURO LOCKS-ULTRA-UNION**

**LOWE & FLETCHER**

**LF-28**

**EURO LOCKS**

**LF-39D**

**EURO LOCKS**

BL....  
BL....N  
1001-2000

**LF-BL**

**BRITAX**

AUSTIN  
CARBODIES  
INNOCENTI  
LAND ROVER  
LOTUS  
MASERATI  
OM IVECO  
ROVER  
VAUXHALL  
BEDFORD  
FIAT IVECO

RO  
BL....N  
1001-2000

**LF-RO**

**LOWE & FLETCHER**

AUSTIN  
CARBODIES  
INNOCENTI  
LAND ROVER  
LOTUS  
MASERATI  
OM IVECO  
ROVER  
VAUXHALL  
BEDFORD  
FIAT IVECO

RO  
BL....N  
1001-2000

**LF-RO.P**

CHRYSLER-FORD (USA)-SUNBEAM  
ROOTES

SL  
5001-7000

**LF-SL**

CHRYSLER-FORD (USA)-SUNBEAM  
ROOTES

SL  
5001-7000

**LF-SL.P**

TRIUMPH  
WILMOT BREEDEN

WR  
1001-2000

**LF-WB**



**LOWE & FLETCHER**

**MACK**

**MARUTI**

**PARA-FOR:**  
 LOWE & FLETCHER (GB)  
 MACK (USA )  
 MARUTI (IND)  
 MAZDA (J)

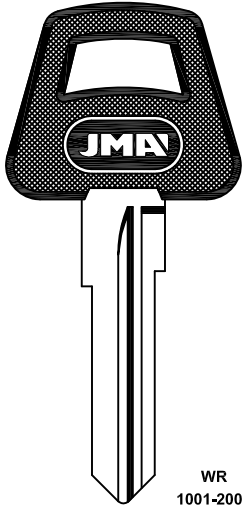

WR  
1001-2000  
LF-WB.P

TRIUMPH  
WILMOT BREEDEN

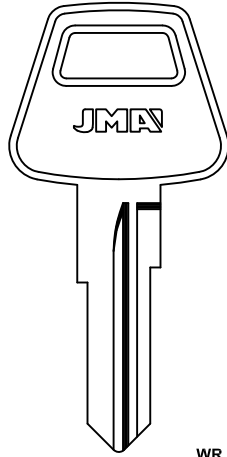

WR  
3000-3999  
5000-5999  
LF-WR

DE LOREAN-FORD (USA)  
WILMOT BREEDEN

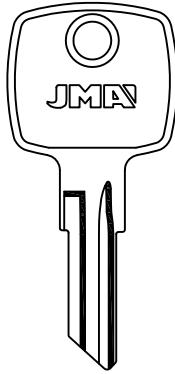

LAT.



MAK-1

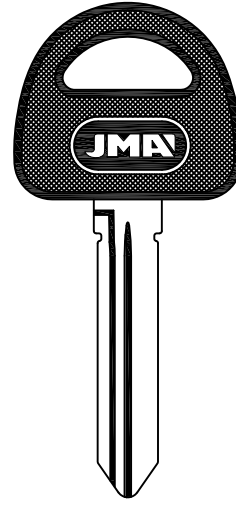

MAR-1.P

**MAZDA**

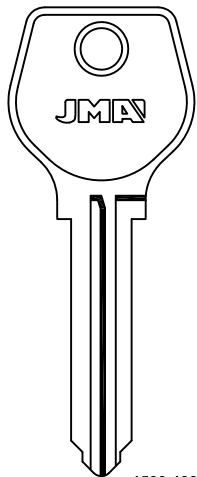

2000-2499 1500-1999  
5000-6100 5000-6100  
MAZ-1I MAZ-1D  
FORD (USA)-MAZDA

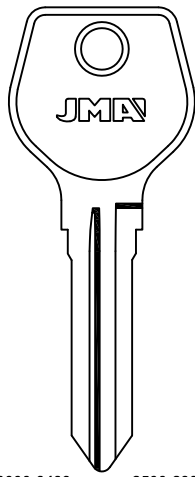

3000-3499 2500-2999  
5000-6100 3500-4600  
MAZ-2I MAZ-2D  
FORD (AUSTRALIA)-MAZDA

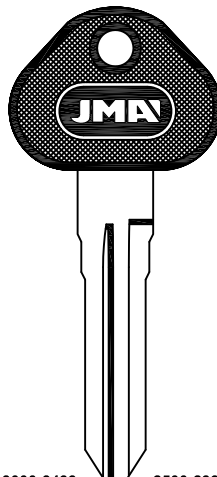

3000-3499 2500-2999  
5000-6100 3500-4600  
MAZ-2I.P MAZ-2D.P  
FORD (AUSTRALIA)-MAZDA

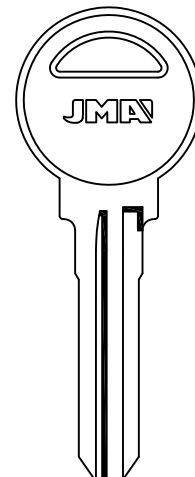

6500-7733  
MAZ-3I MAZ-3D  
MAZDA

**MAZDA**

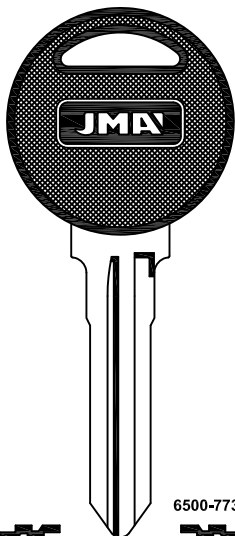

6500-7733  
MAZ-3I.P MAZ-3D.P  
MAZDA

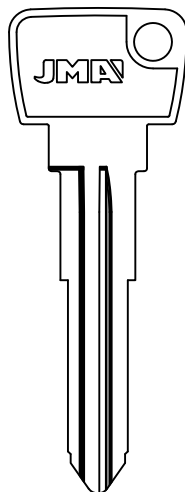

MAZ-4  
MAZDA

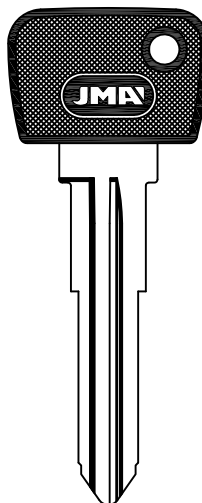

MAZ-4.P  
MAZDA

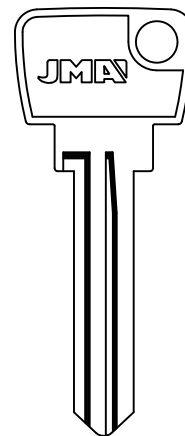

FA....  
6500-7733  
MAZ-5D  
MAZDA



PARA-FOR:

MAZDA (J)

MAZDA

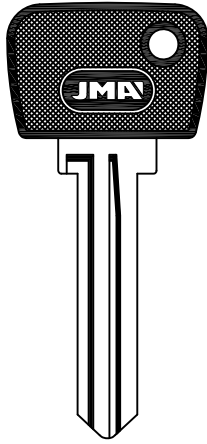

FA...  
6500-7733



MAZDA

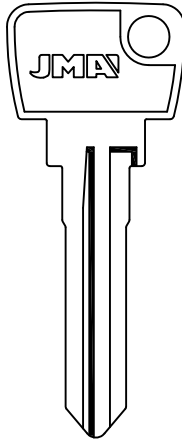

....  
6500-7733



MAZ-6

FORD (USA)-MAZDA

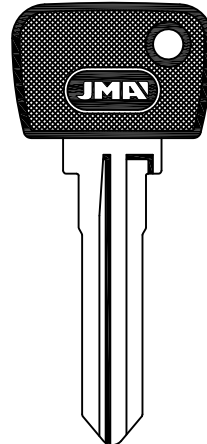

....  
6500-7733



MAZ-6.P

FORD (USA)-MAZDA

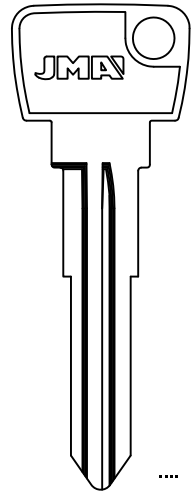

....  
10100-12099



MAZ-7D

MAZDA

MAZDA

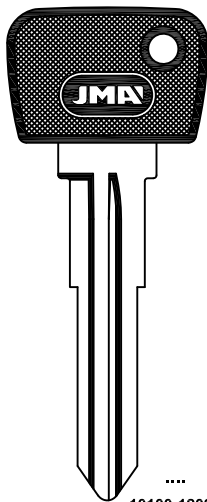

....  
10100-12099



MAZ-7D.P

MAZDA

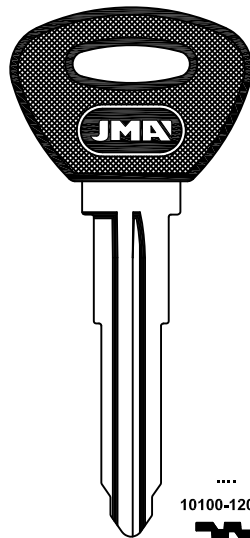

....  
10100-12099



MAZ-7D.P1

MAZDA

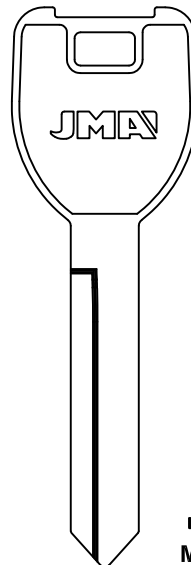

...A...  
101-291  
501-579  
...B...  
101-332  
501-602  
...C...  
101-344  
501-624  
...D...  
101-327  
501-602  
...E...  
101-296  
501-579



MAZ-8D

MAZDA

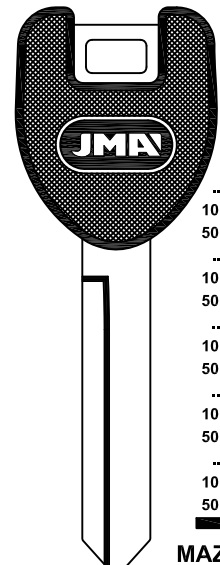

...A...  
101-291  
501-579  
...B...  
101-332  
501-602  
...C...  
101-344  
501-624  
...D...  
101-327  
501-602  
...E...  
101-296  
501-579



MAZ-8D.P

MAZDA

MAZDA

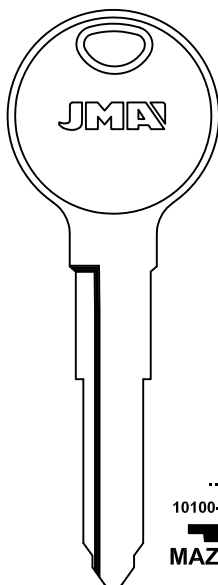

....  
10100-12099



MAZ-11D

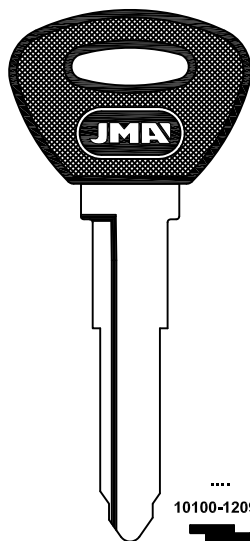

....  
10100-12099



MAZ-11D.P1

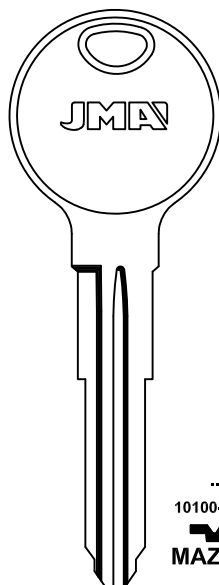

....  
10100-12099



MAZ-13D

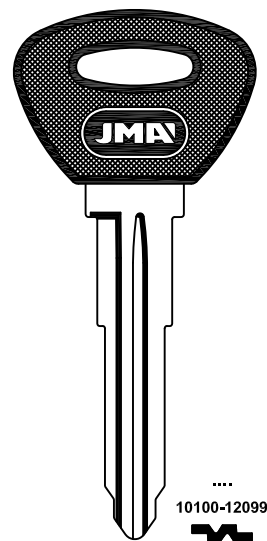

....  
10100-12099



MAZ-13D.P



# MAZDA

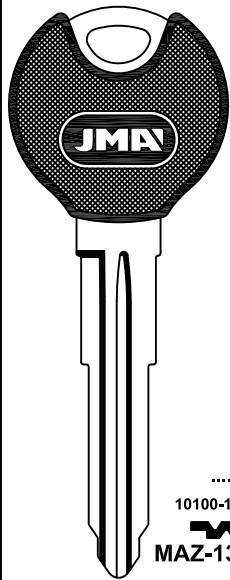

....  
10100-12099  
  
MAZ-13D.P1

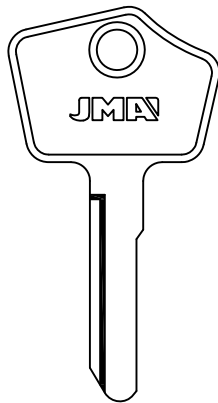

...002-989  
  
MAZ-14D

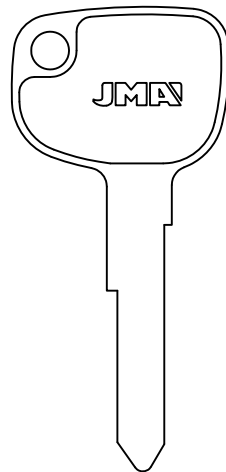

MAZ-15D

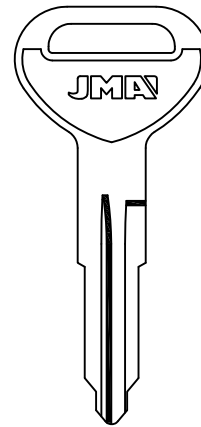

M....  
1-3392  
  
MAZ-16

# PARA-FOR:

- MAZDA (J)
- MERIT-LINDE (D)
- MISCELLANEOUS
- MITSUBISHI (J)

## MAZDA

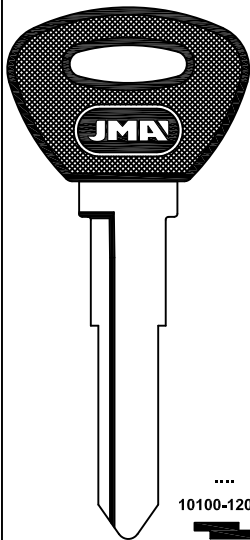

....  
10100-12099  
  
MAZ-21D.P1

## MERIT-LINDE

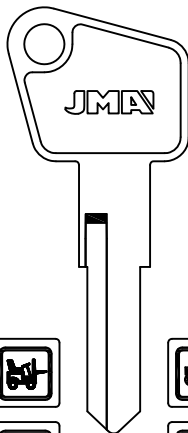

MERI-1D

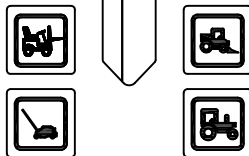
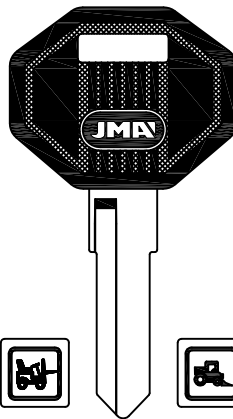

MERI-1D.P

## MISCELLANEOUS

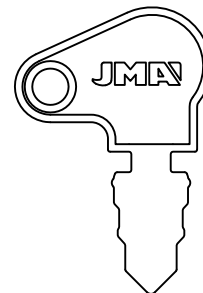

LAT.

MIS-1

## MITSUBISHI

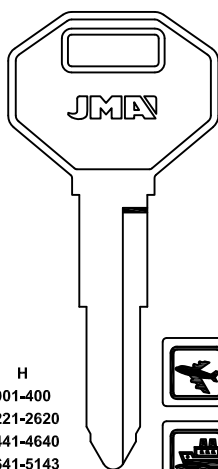

H  
001-400  
2221-2620  
4441-4640  
4641-5143  
E  
2001-3000  
  
MIT-11



MIT-1D  
CHRYSLER-HOLDEN-HSUZU-MITSUBISHI

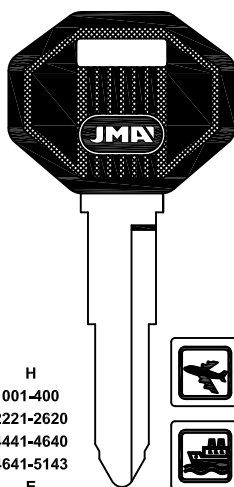

H  
001-400  
2221-2620  
4441-4640  
4641-5143  
E  
2001-3000



MIT-1D.P

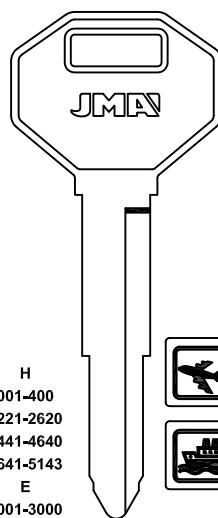

H  
001-400  
2221-2620  
4441-4640  
4641-5143  
E  
2001-3000



MIT-2I

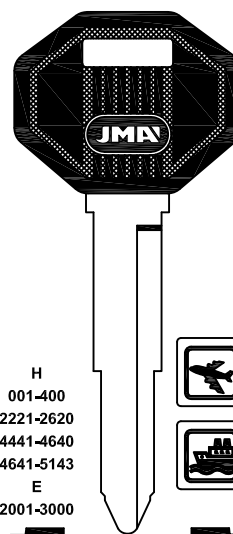

H  
001-400  
2221-2620  
4441-4640  
4641-5143  
E  
2001-3000



MIT-2D  
CHRYSLER-GM-HYUNDAI-HSUZU  
MITSUBISHI-SUZUKI



PARA-FOR:  
MITSUBISHI (J)

MITSUBISHI

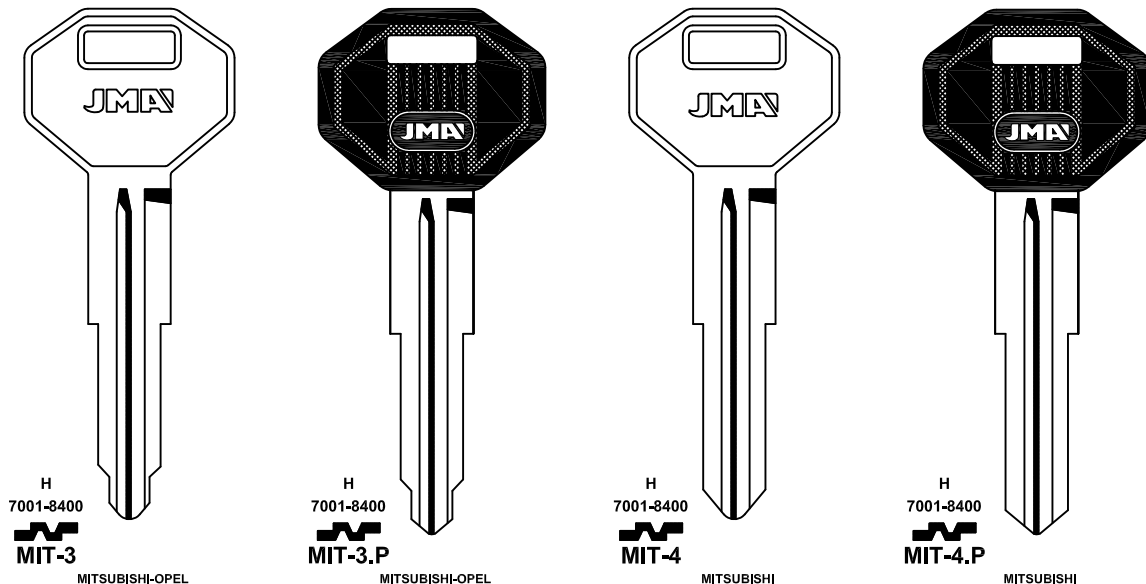

MITSUBISHI

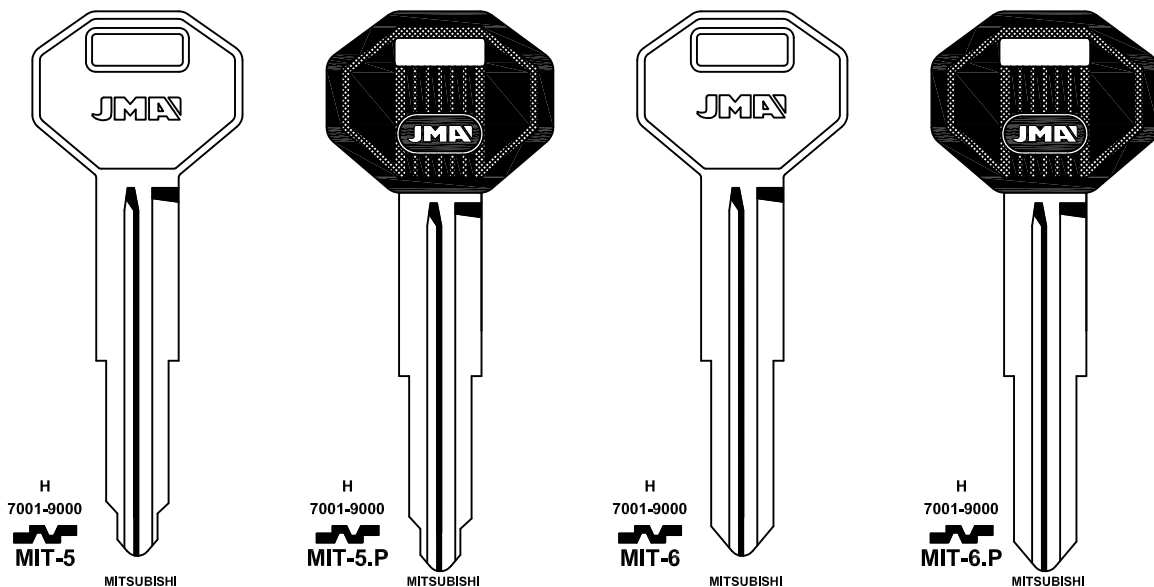

MITSUBISHI

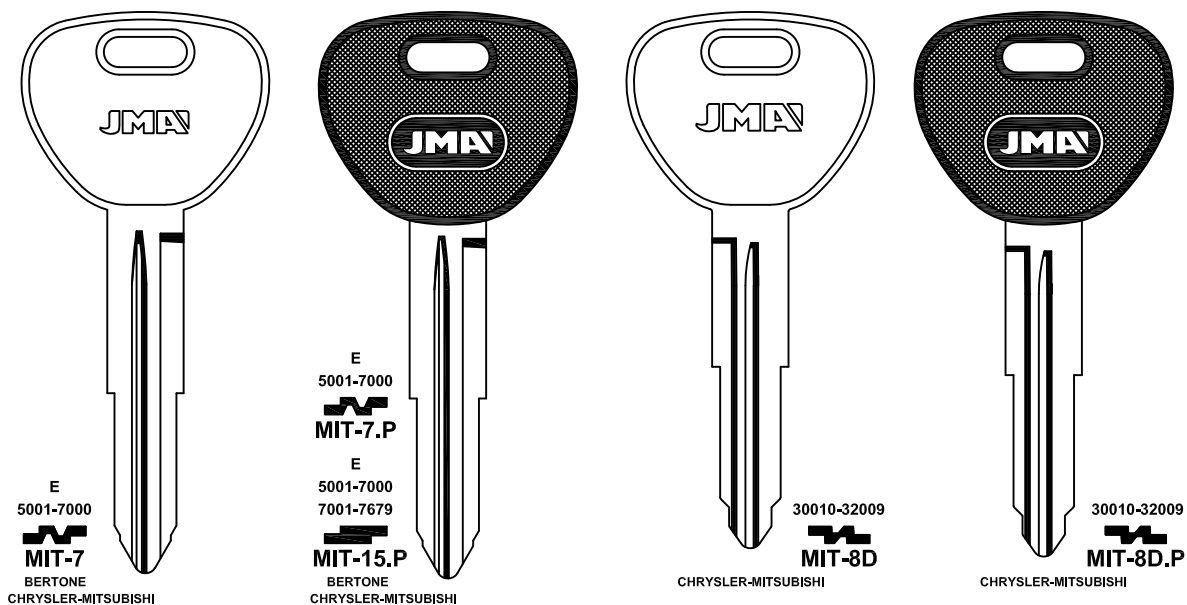



## MITSUBISHI

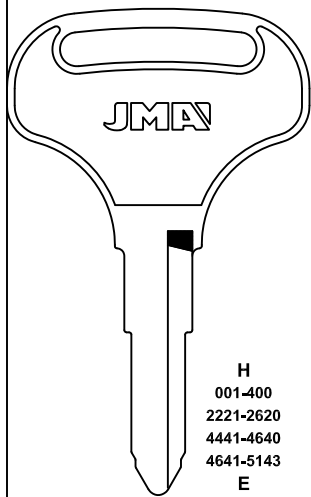

H  
001-400  
2221-2620  
4441-4640  
4641-5143  
E  
2001-3000



MIT-9

MITSUBISHI

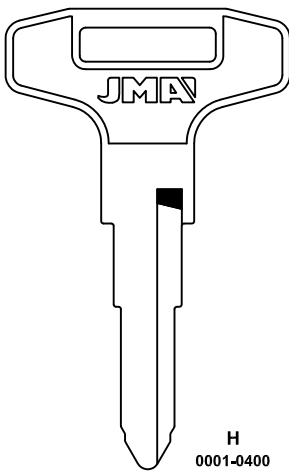

H  
0001-0400  
2221-2620  
4441-5143



MIT-10

MITSUBISHI

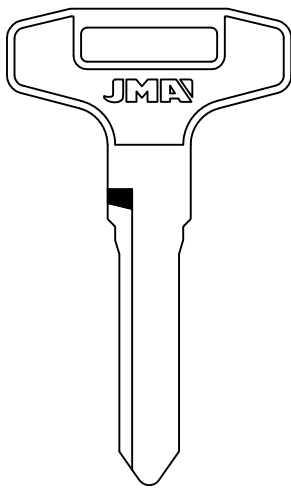

8100-9113



MIT-11D

MITSUBISHI

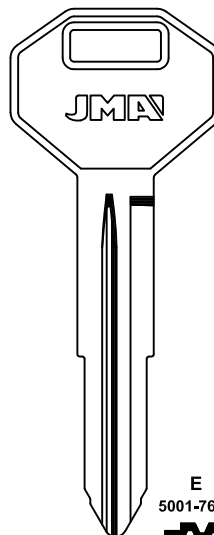

E  
5001-7679



MIT-12

BERTONE-CHRYSLER-MITSUBISHI

## PARA-FOR:

MITSUBISHI (J)

MONDIAL (F)

MOSKVITCH (RUS)

NEIMAN (F)

## MITSUBISHI

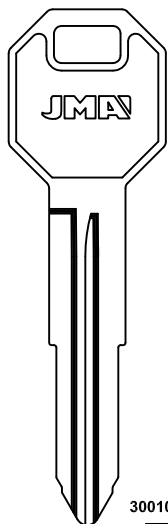

30010-32009



MIT-13D

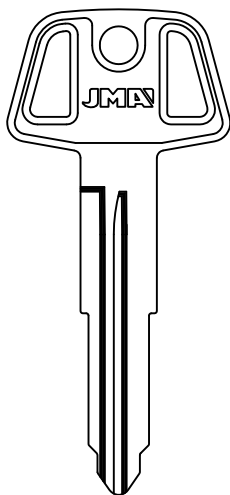

30010-32009



MIT-14D

CHRYSLER-MITSUBISHI

## MONDIAL

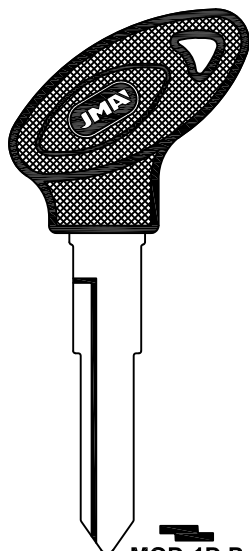

MOD-1D.P

## MOSKVITCH

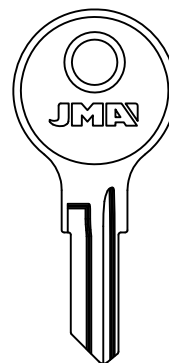

MOS-1

## NEIMAN

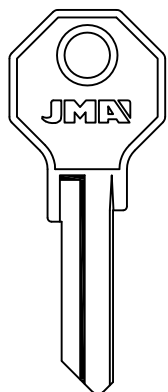

41-4/4

RENAULT

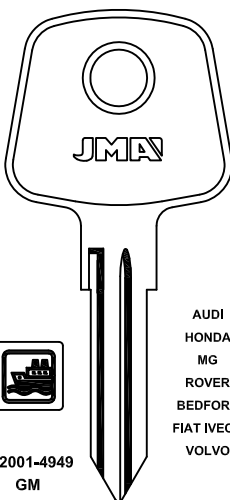

....2001-4949

GM

....2001-3000



NE-1

CLAUSOR

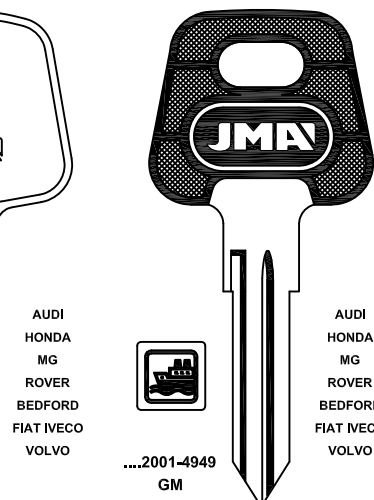

AUDI  
HONDA  
MG  
ROVER  
BEDFORD  
FIAT IVECO  
VOLVO



....2001-4949

GM

....2001-3000



NE-1.P

CLAUSOR

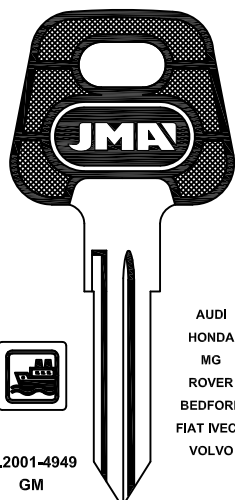

AUDI  
HONDA  
MG  
ROVER  
BEDFORD  
FIAT IVECO  
VOLVO



NE-1D.P

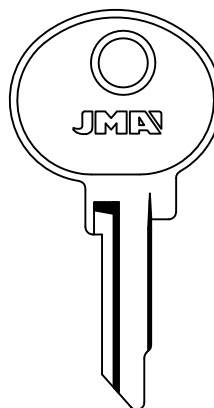

S,T,X,Y

Z,R

1-2-3-5-7



NE-2

CLAUSOR

**JMA**<sup>®</sup>

Copyright by Alejandro Altuna S.A. 2014



ATENCIÓN: Concerniente a las marcas y denominaciones comerciales ver nota en índice.

ATTENTION: Concerning the marks and commercial denominations see note in index.

ATTENTION: Concernant les marques et dénominations commerciales voir la note dans l'index.

ACHTUNG: Beziehen auf die marke und handelsname sehen sie die notiz im index.

**PARA-FOR:**  
NEIMAN (F)

**NEIMAN**

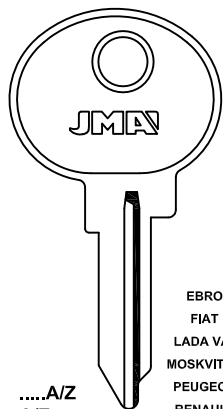

.....A/Z  
A/Z.....  
A/Z.....A/Z  
1 AL 7  
.....A/Z  
0 AL 9



**NE-3**

CLAUSOR

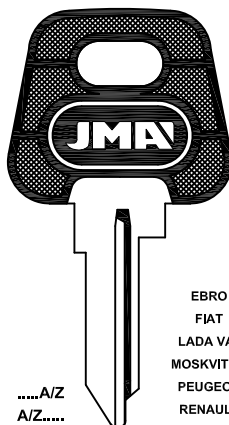

.....A/Z  
A/Z.....  
A/Z.....A/Z  
1 AL 7  
.....A/Z  
0 AL 9



**NE-3.P**

CLAUSOR

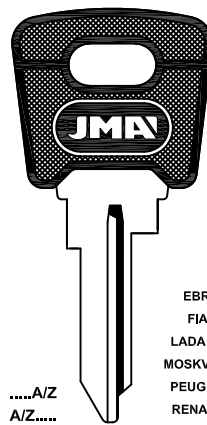

.....A/Z  
A/Z.....  
A/Z.....A/Z  
1 AL 7  
.....A/Z  
0 AL 9



**NE-3.P1**

CLAUSOR

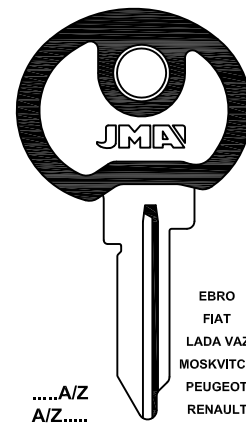

.....A/Z  
A/Z.....  
A/Z.....A/Z  
1 AL 7  
.....A/Z  
0 AL 9



**NE-3.P2**

CLAUSOR

**NEIMAN**

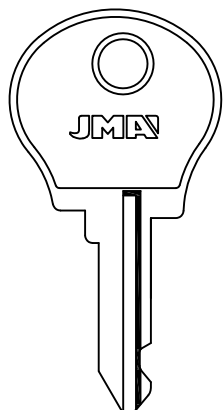

.A/Z.....  
.A/Z.....A/Z  
A/Z.....A/Z  
0 AL 8  
1 AL 7  
A/Z.....1 AL 7 Y A AL E



**NE-4**

11-34-39....  
1 AL 7  
34-39....A/Z  
1 AL 7



**NE-15I**

ACM-ARO DACIA-CITROEN-FIAT-RENAULT  
CLAUSOR

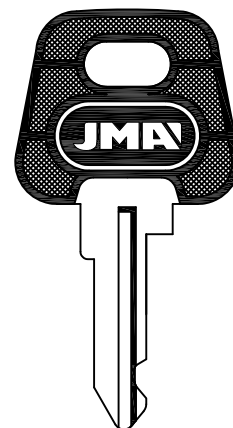

.A/Z.....  
.A/Z.....A/Z  
A/Z.....A/Z  
0 AL 8  
1 AL 7  
A/Z.....1 AL 7 Y A AL E



**NE-4.P**

11-34-39....  
1 AL 7  
34-39....A/Z  
1 AL 7



**NE-15I.P**

ACM-ARO DACIA-CITROEN-FIAT-RENAULT  
CLAUSOR

**NEIMAN**

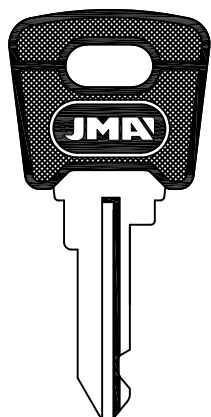

.A/Z.....  
.A/Z.....A/Z  
A/Z.....A/Z  
0 AL 8  
1 AL 7  
A/Z.....1 AL 7 Y A AL E



**NE-4.P1**

11-34-39....  
1 AL 7  
34-39....A/Z  
1 AL 7



**NE-15I.P1**

ACM-ARO DACIA-CITROEN-FIAT-RENAULT  
CLAUSOR

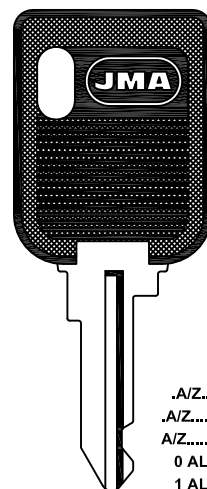

.A/Z.....  
.A/Z.....A/Z  
A/Z.....A/Z  
0 AL 8  
1 AL 7  
A/Z.....1 AL 7 Y A AL E



**NE-4.P2**

RENAULT  
CLAUSOR

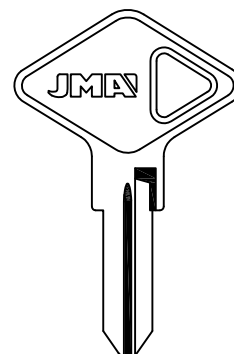

CLAUSOR



## NEIMAN

PARA-FOR:  
NEIMAN (F)

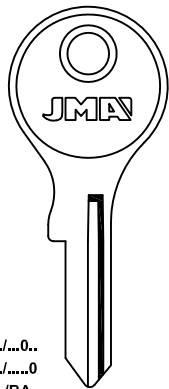

.0.../...0...  
....0/....0  
AA.../BA...  
CA.../EA...  
Z.../Z...  
..Z.../..Z...  
...Z.../...Z...  
1 AL 5



**NE-6**

VARIAS MARCAS DE MOTOS

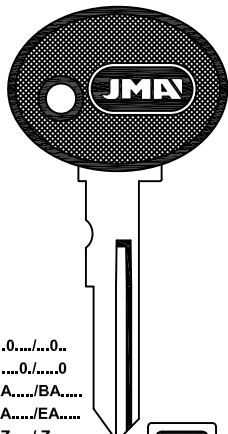

.0.../...0...  
....0/....0  
AA.../BA...  
CA.../EA...  
Z.../Z...  
..Z.../..Z...  
...Z.../...Z...  
1 AL 5



**NE-6.P**

VARIAS MARCAS DE MOTOS

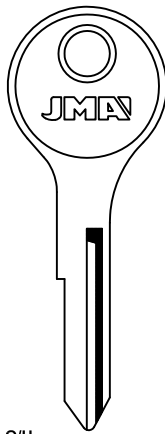

....O/H....  
..H.../..H...  
...H.../...H...  
1 AL 5

**NE-7**

BMW

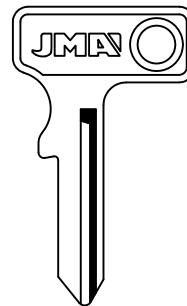

.0.../...0...  
....0/....0  
AA.../BA...  
CA...  
1 AL 5

**NE-8**

VARIAS MARCAS DE MOTOS  
CLAUSOR

## NEIMAN

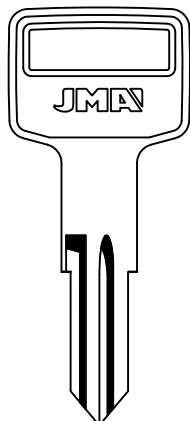

....6250-6499

**NE-9**

VOLVO  
CLAUSOR

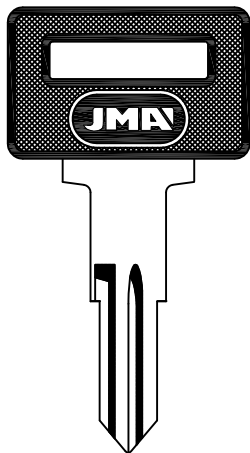

....6250-6499

**NE-9.P**

VOLVO  
CLAUSOR

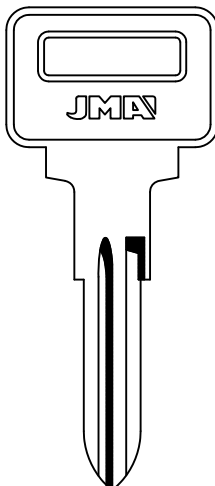

....7001-9000

**NE-10**

DE LOREAN-MG-VOLVO-BEDFORD

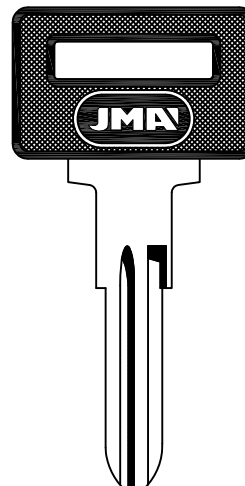

....7001-9000

**NE-10.P**

DE LOREAN-MG-VOLVO-BEDFORD

## NEIMAN

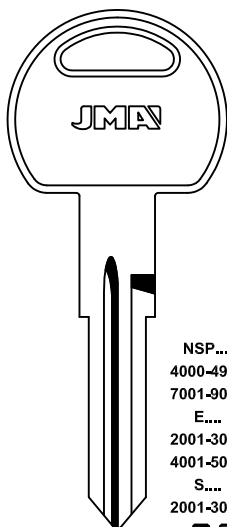

NSP...  
4000-4999  
7001-9000  
E...  
2001-3000  
4001-5000  
S...  
2001-3000

**NE-11**

FORD-NISSAN-ROVER-STERLING  
DAF-KENWORTH

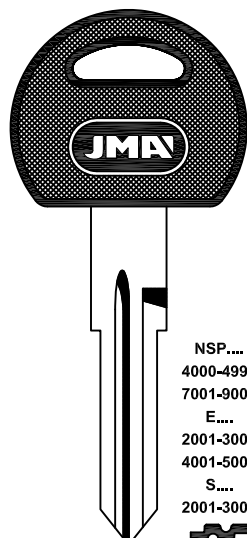

NSP...  
4000-4999  
7001-9000  
E...  
2001-3000  
4001-5000  
S...  
2001-3000

**NE-11.P**

FORD-NISSAN-ROVER-STERLING  
DAF-KENWORTH

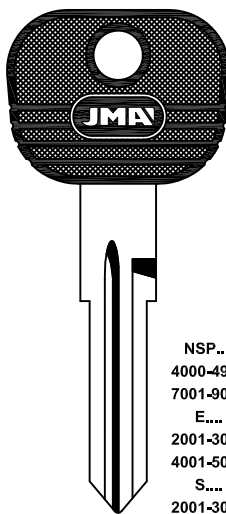

NSP...  
4000-4999  
7001-9000  
E...  
2001-3000  
4001-5000  
S...  
2001-3000

**NE-11.P1**

LAND RANGE ROVER-ROVER

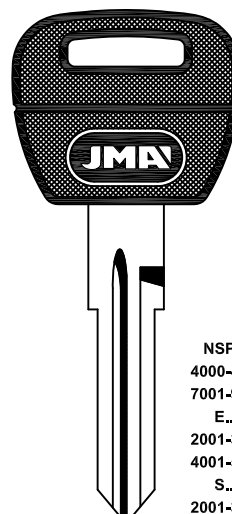

NSP...  
4000-4999  
7001-9000  
E...  
2001-3000  
4001-5000  
S...  
2001-3000

**NE-11.P2**

ROVER

**JMA**<sup>®</sup>

Copyright by Alejandro Altuna S.A. 2014



ATENCIÓN: Concerniente a las marcas y denominaciones comerciales ver nota en índice.  
ATTENTION: Concerning the marks and commercial denominations see note in index.  
ATTENTION: Concernant les marques et dénominations commerciales voir la note dans l'index.  
ACHTUNG: Beziehen auf die marke und handelsname sehen sie die notiz im index.

**PARA-FOR:**  
NEIMAN (F)

**NEIMAN**

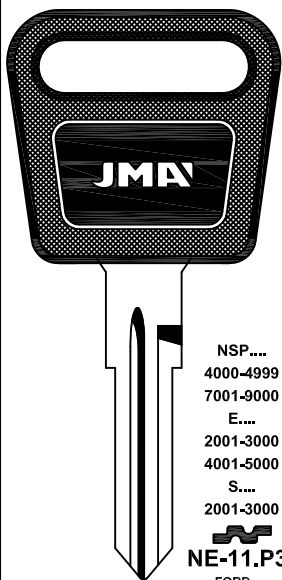

NSP...  
4000-4999  
7001-9000  
E...  
2001-3000  
4001-5000  
S...  
2001-3000  
  
**NE-11.P3**  
FORD

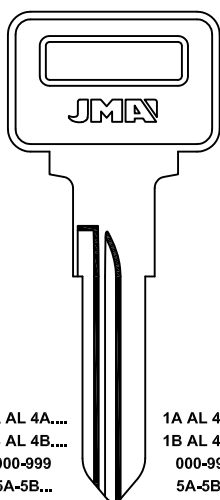

1A AL 4A...  
1B AL 4B...  
000-999  
5A-5B...  
000-746  
  
**NE-12**  
VOLVO

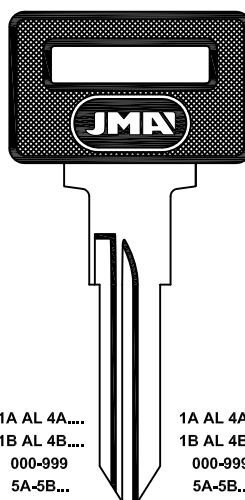

1A AL 4A...  
1B AL 4B...  
000-999  
5A-5B...  
000-746  
  
**NE-12.P**  
VOLVO

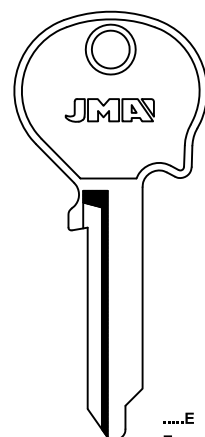

....E  
E...  
N...  
X...  
1 AL 5  
  
**NE-13**  
VOLVO

**NEIMAN**

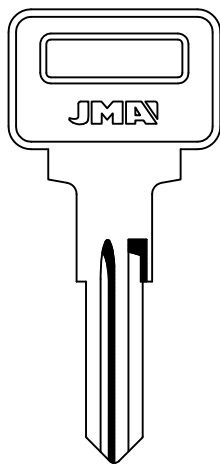

NP...  
1-1000  
  
**NE-14**  
ROVER  
CEM

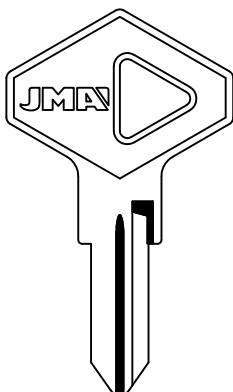

T...001-999  
V...000-922  
2.....  
2.....A/Z  
B-C-D-E-G  
  
**NE-16**  
AMERICAN MOTORS-RENAULT  
CLAUSOR

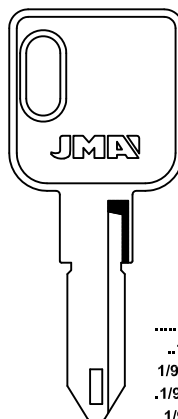

....1/9..A/Z  
..1/9....  
1/9.....A/Z  
.1/9.....A/Z  
..1/9.....A/Z  
...1/9...A/Z  
....1/9..A/Z  
.....1/9..A/Z  
M-N-P-R-S  
  
**NE-19**  
AMERICAN MOTORS-CHRYSLER-PEUGEOT  
RENAULT

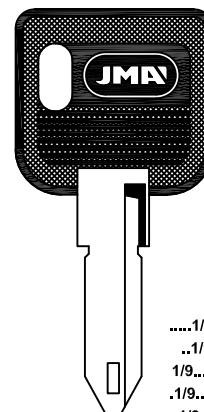

....1/9..A/Z  
..1/9....  
1/9.....A/Z  
.1/9.....A/Z  
..1/9.....A/Z  
...1/9...A/Z  
....1/9..A/Z  
.....1/9..A/Z  
M-N-P-R-S  
  
**NE-19.P**  
RENAULT

**NEIMAN**

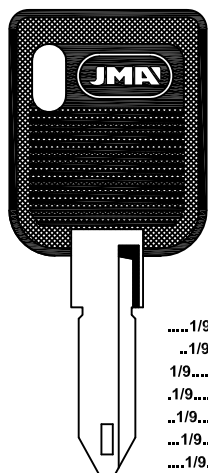

....1/9..A/Z  
..1/9....  
1/9.....A/Z  
.1/9.....A/Z  
..1/9.....A/Z  
...1/9...A/Z  
....1/9..A/Z  
.....1/9..A/Z  
M-N-P-R-S  
  
**NE-19.P1**  
RENAULT

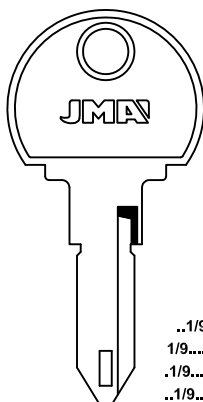

..1/9....  
1/9.....A/Z  
.1/9.....A/Z  
..1/9.....A/Z  
...1/9...A/Z  
....1/9..A/Z  
.....1/9..A/Z  
M-N-P-R-S  
  
**NE-20**  
PEUGEOT

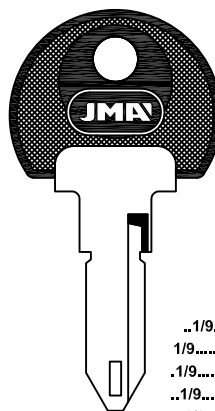

..1/9....  
1/9.....A/Z  
.1/9.....A/Z  
..1/9.....A/Z  
...1/9...A/Z  
....1/9..A/Z  
.....1/9..A/Z  
M-N-P-R-S  
  
**NE-20.P**  
PEUGEOT

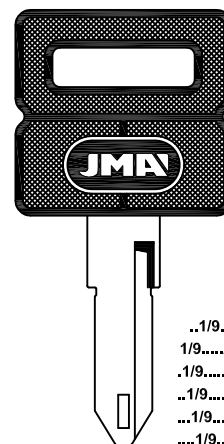

..1/9....  
1/9.....A/Z  
.1/9.....A/Z  
..1/9.....A/Z  
...1/9...A/Z  
....1/9..A/Z  
.....1/9..A/Z  
M-N-P-R-S  
  
**NE-20.P1**  
PEUGEOT



# NEIMAN

PARA-FOR:  
NEIMAN (F)

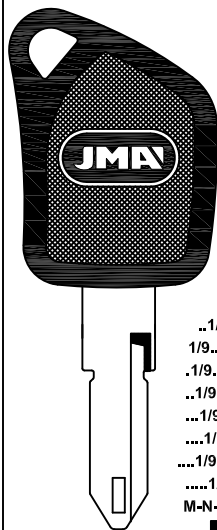

.....  
..1/9....  
1/9.....A/Z  
.1/9.....A/Z  
..1/9.....A/Z  
...1/9...A/Z  
....1/9..A/Z  
.....1/9..A/Z  
M-N-P-R-S

**NE-20.P2**

PEUGEOT

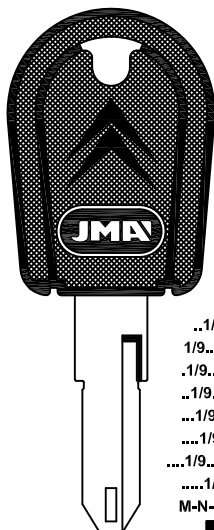

.....  
..1/9....  
1/9.....A/Z  
.1/9.....A/Z  
..1/9.....A/Z  
...1/9...A/Z  
....1/9..A/Z  
.....1/9..A/Z  
M-N-P-R-S

**NE-20.P3**

CITROEN

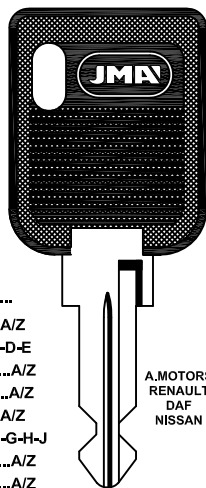

.....  
.....A/Z  
B-C-D-E  
1/9.....A/Z  
1/9.....A/Z  
.....A/Z  
B-D-E-G-H-J  
.1/9.....A/Z  
.1/9.....A/Z  
E-M-N-P-R

**NE-22.P**

CLAUSOR

A.MOTORS  
RENAULT  
DAF  
NISSAN

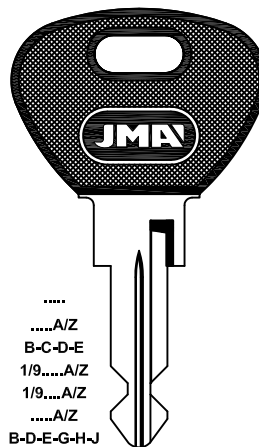

.....  
.....A/Z  
B-C-D-E  
1/9.....A/Z  
1/9.....A/Z  
.....A/Z  
B-D-E-G-H-J  
.1/9.....A/Z  
.1/9.....A/Z  
E-M-N-P-R

**NE-22.P1**

CITROEN-PEUGEOT-PEGASO

CLAUSOR

# NEIMAN

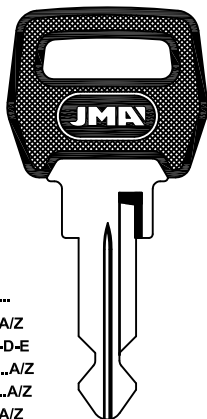

.....  
.....A/Z  
B-C-D-E  
1/9.....A/Z  
1/9.....A/Z  
.....A/Z  
B-D-E-G-H-J  
.1/9.....A/Z  
.1/9.....A/Z  
E-M-N-P-R

**NE-22.P2**

MAZDA-TALBOT SIMCA-DAF

CLAUSOR

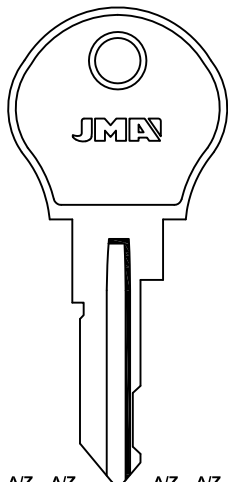

A/Z.....A/Z  
0-4-6-8-9

**NE-23**

MAZDA  
DATSUN

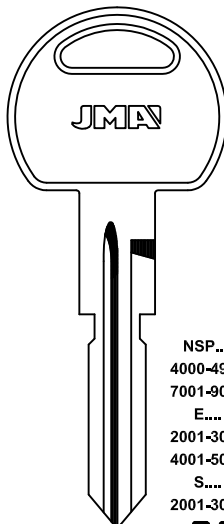

NSP....  
4000-4999  
7001-9000  
E....  
2001-3000  
4001-5000  
S....  
2001-3000

**NE-24**

FORD-ROVER-STERLING

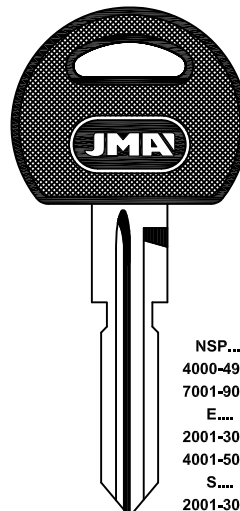

NSP....  
4000-4999  
7001-9000  
E....  
2001-3000  
4001-5000  
S....  
2001-3000

**NE-24.P**

FORD-ROVER-STERLING

# NEIMAN

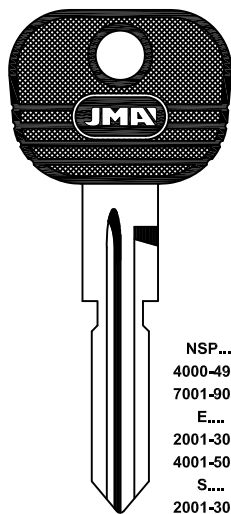

NSP....  
4000-4999  
7001-9000  
E....  
2001-3000  
4001-5000  
S....  
2001-3000

**NE-24.P1**

LAND RANGE ROVER-ROVER

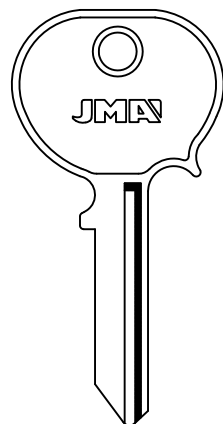

.....A  
.....D  
.....F  
1 AL 5

**NE-25**

ALFA ROMEO-FERRARI-STEYR PUCH

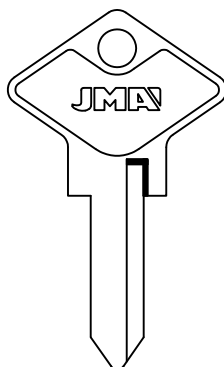

**NE-27**

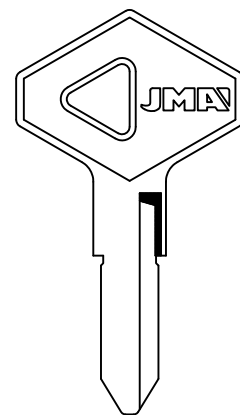

..1/9....A/Z  
M-N-P-R-S

**NE-28**

CHRYSLER (EAGLE)-RENAULT



PARA-FOR:  
NEIMAN (F)

NEIMAN

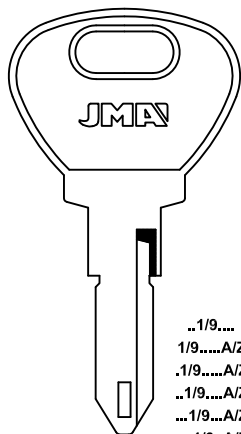

..1/9....  
1/9....A/Z  
.1/9....A/Z  
..1/9....A/Z  
...1/9....A/Z  
....1/9..A/Z  
....1/9..A/Z A/Z  
.....1/9.A/Z  
.....1/9.A/Z  
M-N-P-R-S  
 **NE-29**

PEUGEOT

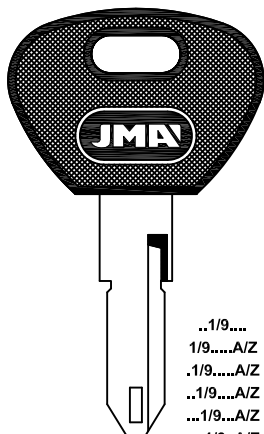

..1/9....  
1/9....A/Z  
.1/9....A/Z  
..1/9....A/Z  
...1/9....A/Z  
....1/9..A/Z  
....1/9..A/Z A/Z  
.....1/9.A/Z  
.....1/9.A/Z  
M-N-P-R-S  
 **NE-29.P**

PEUGEOT

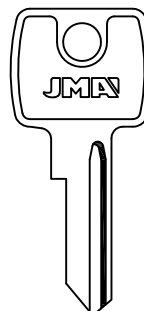

....  
5001-6278

**NE-30**

BASTA

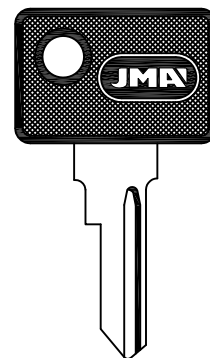

....  
5001-6278

**NE-30.P**

BASTA

NEIMAN

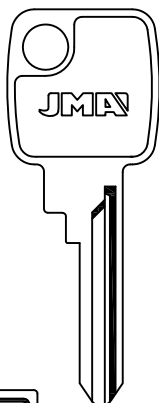

..1/9....A/Z  
M-N-P-R-S

**NE-31**

BASTA

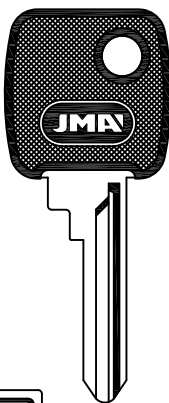

..1/9....A/Z  
M-N-P-R-S

**NE-31.P**

BASTA

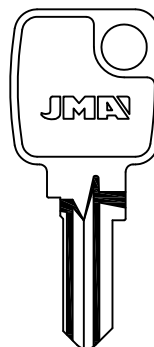

.B...3-5-7-L  
..B...3-5-7-L/2-3-5-7-L  
...B...3-5-7-L  
....B...3-5-7-L

**NE-32**

BASTA



.B...3-5-7-L  
..B...3-5-7-L/2-3-5-7-L  
...B...3-5-7-L  
....B...3-5-7-L

**NE-32.P**

BASTA

NEIMAN

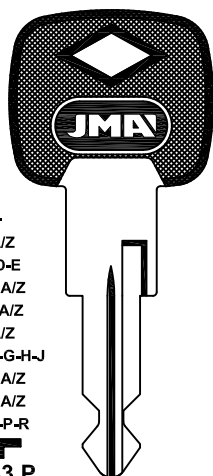

.....  
....A/Z  
B-C-D-E  
1/9....A/Z  
1/9....A/Z  
....A/Z  
B-D-E-G-H-J  
.1/9....A/Z  
.1/9....A/Z  
E-M-N-P-R  
 **NE-33.P**

**NE-44.P**

RENAULT  
CLAUSOR

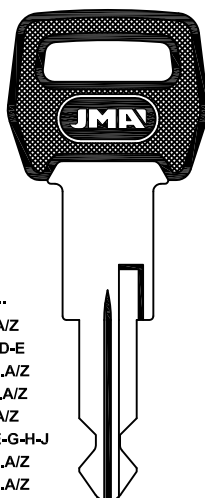

.....  
....A/Z  
B-C-D-E  
1/9....A/Z  
1/9....A/Z  
....A/Z  
B-D-E-G-H-J  
.1/9....A/Z  
.1/9....A/Z  
E-M-N-P-R  
 **NE-33.P1**

**NE-33.P1**

TALBOT SIMCA  
CLAUSOR



LAT.

NA/Z.....  
0 AL 9  
A AL F

**NE-34.P**

PEUGEOT

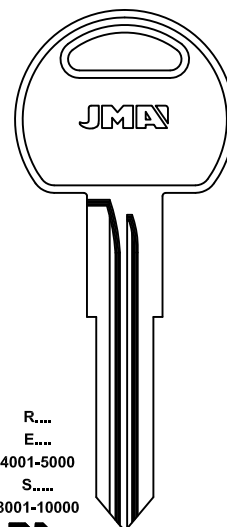

R...  
E...  
4001-5000  
S.....  
8001-10000

**NE-35**

HONDA-ROVER



# NEIMAN

PARA-FOR:  
NEIMAN (F)

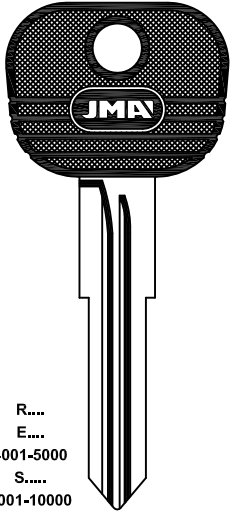

R....  
E....  
4001-5000  
S....  
8001-10000

**NE-35.P**

ROVER

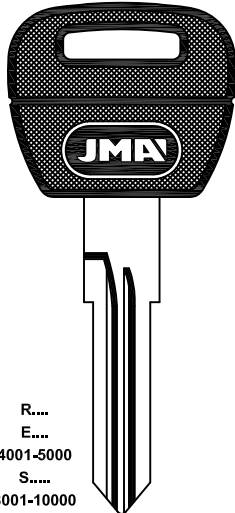

R....  
E....  
4001-5000  
S....  
8001-10000

**NE-35.P2**

HONDA-ROVER

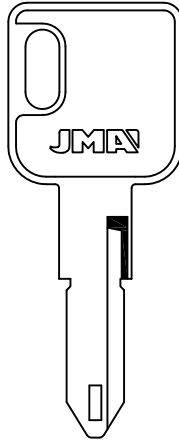

..1/9....  
1/9....A/Z  
.1/9....A/Z  
..1/9....A/Z  
...1/9....A/Z  
....1/9....A/Z  
.....1/9..A/Z A/Z  
M-N-P-R-S

**NE-36**

CITROEN-PEUGEOT-RENAULT

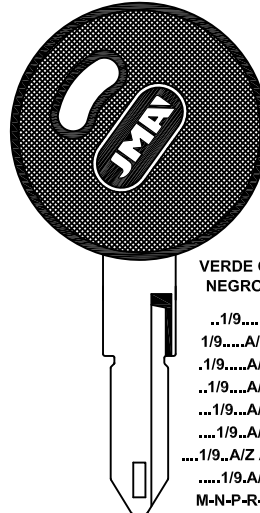

VERDE O  
NEGRO

..1/9....  
1/9....A/Z  
.1/9....A/Z  
..1/9....A/Z  
...1/9....A/Z  
....1/9....A/Z  
.....1/9..A/Z A/Z  
M-N-P-R-S

**NE-36.P**

RENAULT

# NEIMAN

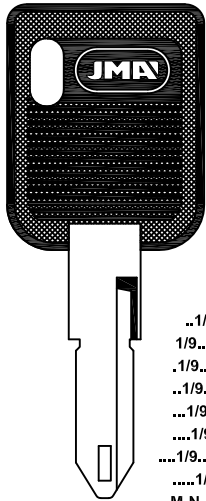

..1/9....  
1/9....A/Z  
.1/9....A/Z  
..1/9....A/Z  
...1/9....A/Z  
....1/9....A/Z  
.....1/9..A/Z A/Z  
M-N-P-R-S

**NE-36.P1**

CITROEN-PEUGEOT-RENAULT

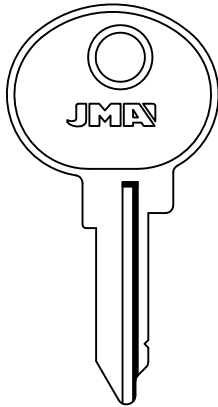

....A/Z  
1-2-3-5-7

**NE-37**

PEUGEOT

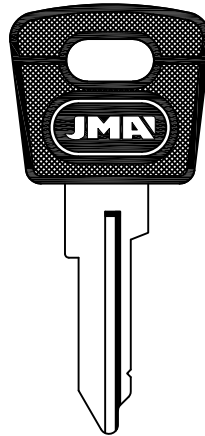

....A/Z  
1-2-3-5-7

**NE-37.P**

PEUGEOT

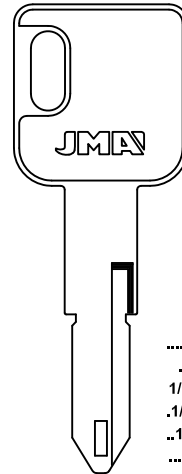

.....1/9..A/Z  
..1/9....  
1/9....A/Z  
.1/9....A/Z  
..1/9....A/Z  
...1/9....A/Z  
....1/9....A/Z  
.....1/9..A/Z A/Z

**NE-38**

RENAULT

# NEIMAN

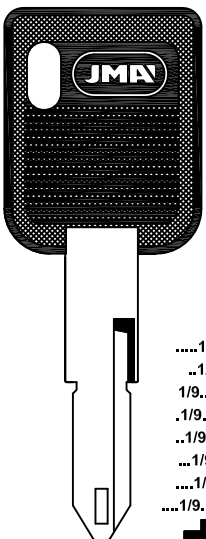

.....1/9..A/Z  
..1/9....  
1/9....A/Z  
.1/9....A/Z  
..1/9....A/Z  
...1/9....A/Z  
....1/9....A/Z  
.....1/9..A/Z A/Z

**NE-38.P1**

RENAULT

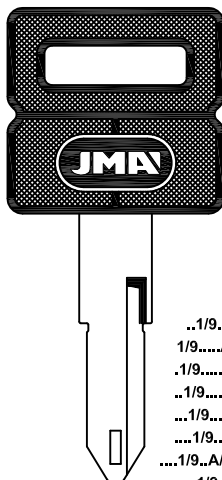

..1/9....  
1/9....A/Z  
.1/9....A/Z  
..1/9....A/Z  
...1/9....A/Z  
....1/9....A/Z  
.....1/9..A/Z A/Z  
M-N-P-R-S

**NE-39.P**

PEUGEOT

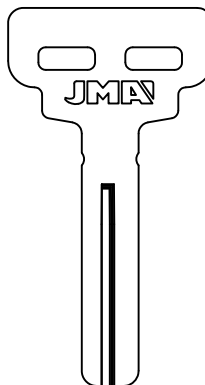

LAT.

7,5  
3

**NE-40**

VOLVO  
YMOS

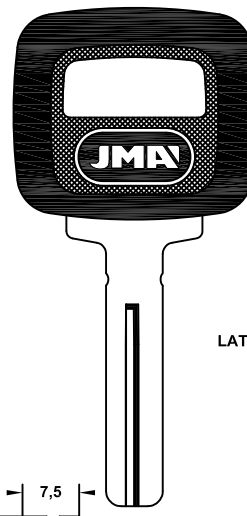

LAT.

7,5  
3

**NE-40.P**

VOLVO  
YMOS



PARA-FOR:  
NEIMAN (F-RA)

NEIMAN

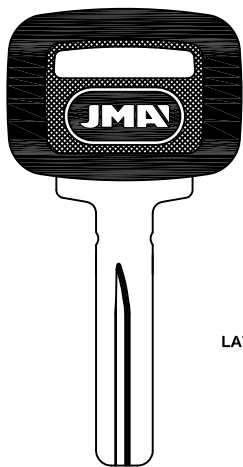

7,5  
3  
NE-41.P  
VOLVO  
YMOS

LAT.

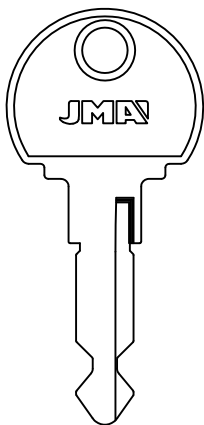

NE-42  
PEUGEOT

NEIMAN (RA)

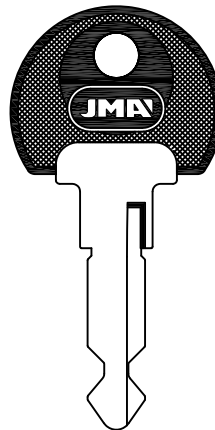

NE-42.P  
PEUGEOT

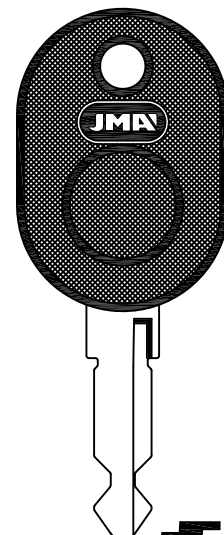

NE-42.P1  
PEUGEOT

NEIMAN (RA)

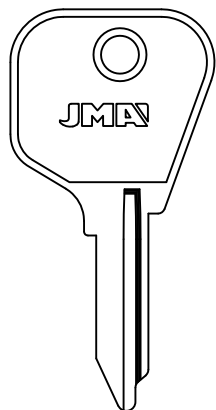

NE-43  
PEUGEOT

NEIMAN

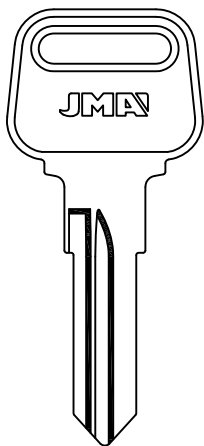

NE-45  
PEUGEOT

NEIMAN (RA)

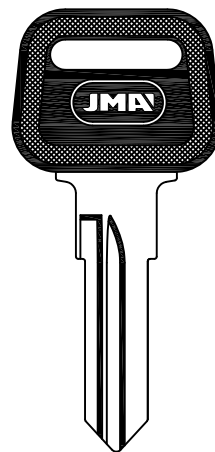

NE-45.P  
PEUGEOT

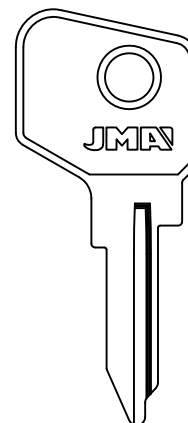

NE-46  
FIAT

NEIMAN (RA)

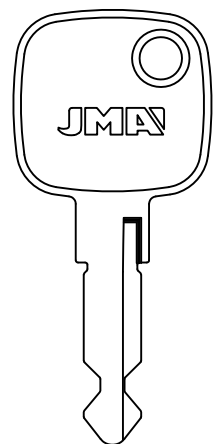

NE-47  
FIAT

NEIMAN

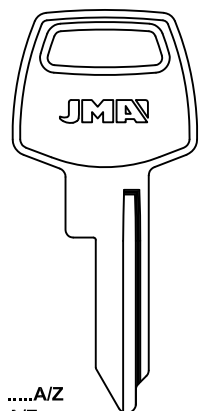

.....A/Z  
A/Z.....  
A/Z.....A/Z  
1 AL 7  
.....A/Z  
0 AL 9  
NE-48

CLAUSOR

NEIMAN (RA)

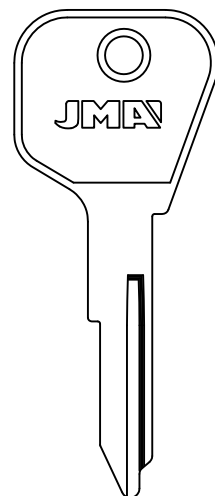

NE-49

NEIMAN

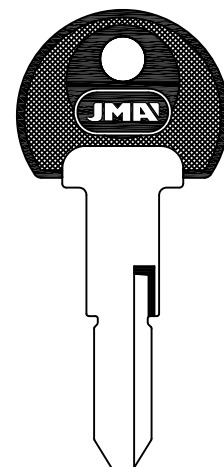

M,N,P,R,S  
1/9...A/Z  
NE-50.P





**NEIMAN**

**NEIMAN (RA)**

**PARA-FOR:**  
NEIMAN (F-RA)

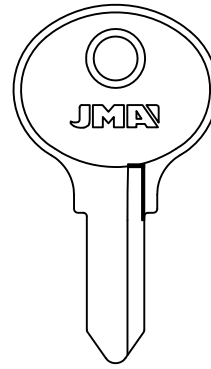
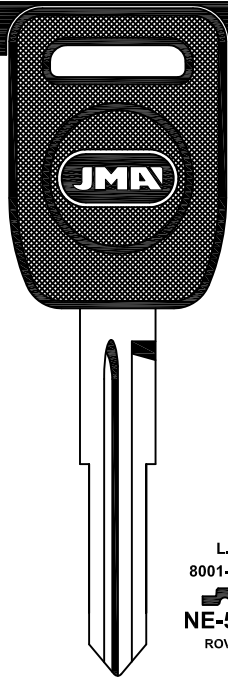
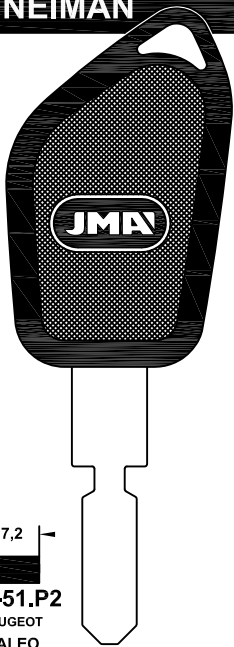

ALP.

3,5 7,2  
**NE-51.P2**  
PEUGEOT  
VALEO

L.....  
8001-10000  
**NE-52.P**  
ROVER

**NE-53**

**NEIMAN (RA)**

**NEIMAN**

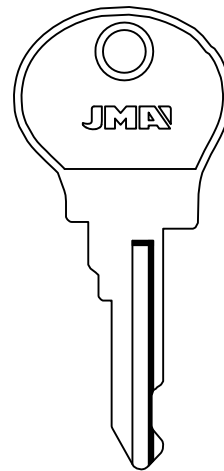
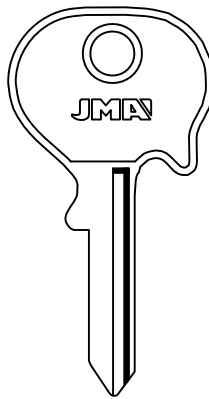
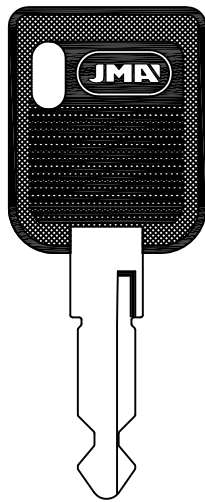
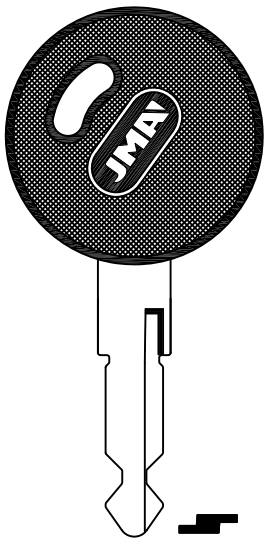

**NE-54.P**  
RENAULT

**NE-55.P**  
RENAULT

.....  
1 AL 5  
**NE-56**

**NE-57**  
MAZDA

**NEIMAN**

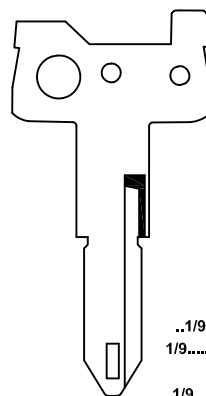
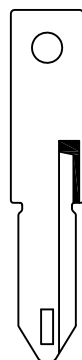
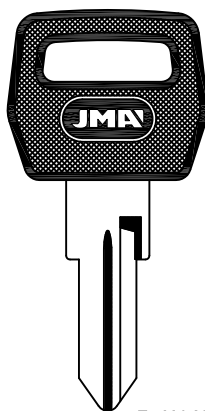
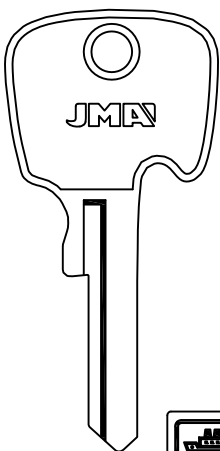

N.....1 AL 5  
**NE-58D**

T...001-999  
V...000-922  
2.....  
2.....A/Z  
B-C-D-E-G  
**NE-59.P**

..1/9....  
1/9....A/Z  
.1/9....A/Z  
..1/9....A/Z  
...1/9....A/Z  
....1/9..A/Z  
.....1/9..A/Z A/Z  
.....1/9..A/Z  
M-N-P-R-S  
**NE-60C1**

..1/9....  
1/9....A/Z  
..1/9....A/Z  
...1/9....A/Z  
....1/9..A/Z  
.....1/9..A/Z A/Z  
.....1/9..A/Z  
M-N-P-R-S  
**NE-60C2**

BOMORO-BOSCH

CLAUSOR



**PARA-FOR:**

NEIMAN (F)

NISSAN (J)

**NEIMAN**

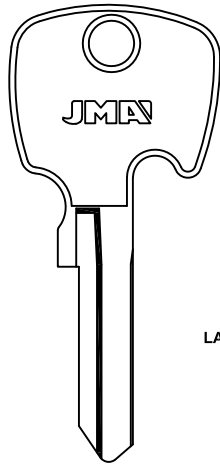

LAT.

D...  
1-2-3-4-5  
  
NE-61D

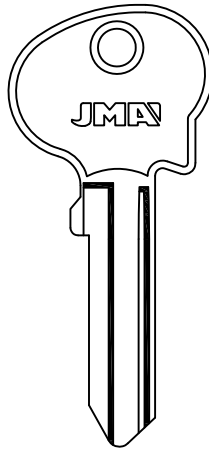

LAT.

8...  
1-2-3-4-5  
  
NE-62

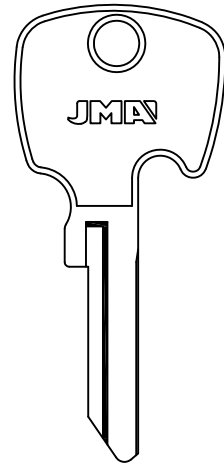

M...  
1-2-3-4-5  
  
NE-63D

**NISSAN**

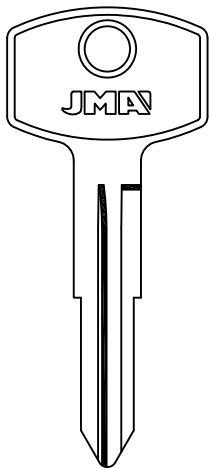

F  
0001-1000  
1001-2000  
M  
4001-5000  
  
DAT-1I

M  
0001-1000  
5001-6000  
N  
1001-2000  
  
DAT-1D

M  
6001-7000  
W  
0001-1000  
  
DAT-2I

M  
7001-8000  
  
DAT-2D

NISSAN-SUBARU  
DATSUN-WASO

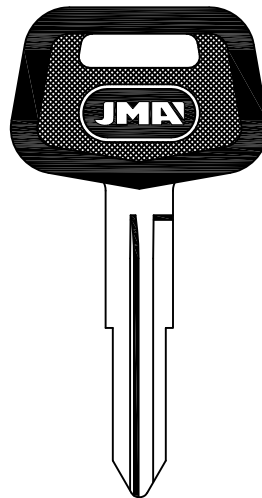

F  
0001-1000  
1001-2000  
M  
4001-5000  
  
DAT-1I.P

M  
0001-1000  
5001-6000  
N  
1001-2000  
  
DAT-1D.P

M  
6001-7000  
W  
0001-1000  
  
DAT-2I.P

M  
7001-8000  
  
DAT-2D.P

NISSAN-SUBARU  
DATSUN-WASO

**NISSAN**

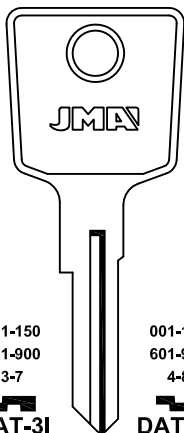

001-150  
601-900  
3-7  
  
DAT-3I

001-150  
601-900  
4-8  
  
DAT-3D

001-150  
601-900  
1-5  
  
DAT-4I

001-150  
601-900  
6-9  
  
DAT-4D

MAZDA-NISSAN-SUBARU  
DATSUN

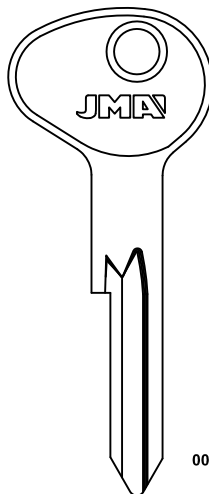

VH  
0001-3948  
K  
00001-14000  
  
DAT-5D

NISSAN  
DATSUN-WASO

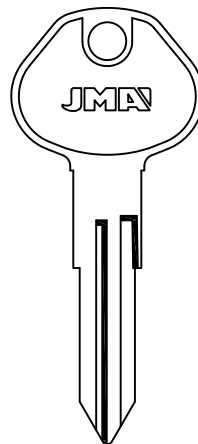

X  
0001-8000  
  
DAT-6

DAT-6D

Y  
0001-8000  
8001-9000  
  
DAT-7

ALFA ROMEO-DELTA-EBRO-GMC-INFINITI-NISSAN-SUBARU  
DATSUN



# NISSAN

PARA-FOR:  
NISSAN (J)



X....1-9000  
  
DAT-6C1

VALEO

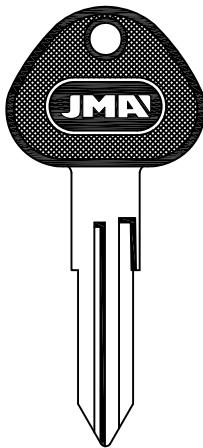

X  
0001-8000  
  
DAT-6.P

DAT-6D.P

Y  
0001-8000  
8001-9000  
  
DAT-7.P

ALFA ROMEO-DELTA-EBRO-GMC-INFINITI-NISSAN-SUBARU  
DATSUN

# NISSAN

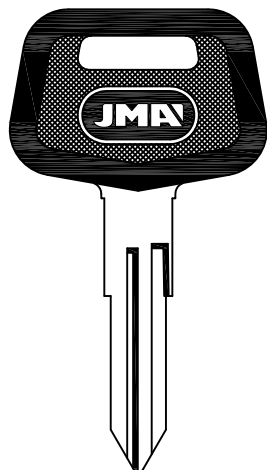

X  
0001-8000  
  
DAT-6.P1

DAT-6D.P1

Y  
0001-8000  
8001-9000  
  
DAT-7.P1

INFINITI-NISSAN-SUBARU  
DATSUN

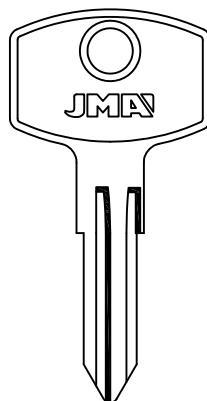

F  
0001-1000  
1001-2000  
M  
4001-5000  
  
DAT-8I

M  
0001-1000  
5001-6000  
N  
1001-2000  
  
DAT-8

M  
6001-7000  
7001-800  
W  
0001-1000  
  
DAT-9I

M  
7001-800  
  
DAT-9D

NISSAN-SUBARU  
DATSUN

# NISSAN

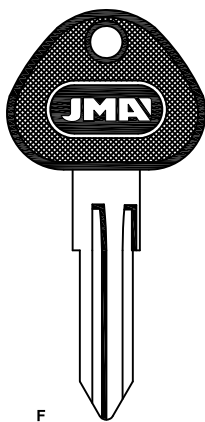

F  
0001-1000  
1001-2000  
M  
4001-5000  
  
DAT-8I.P1

NISSAN-SUBARU  
DATSUN

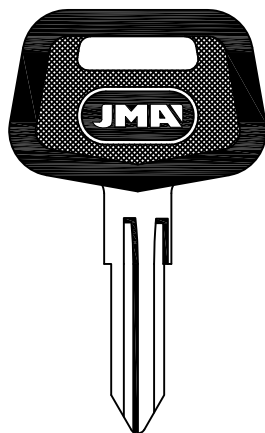

F  
0001-1000  
1001-2000  
M  
4001-5000  
  
DAT-8I.P

M  
0001-1000  
5001-6000  
N  
1001-2000  
  
DAT-8.P

M  
6001-7000  
7001-800  
W  
0001-1000  
  
DAT-9I.P

M  
7001-800  
  
DAT-9D.P

NISSAN-SUBARU  
DATSUN

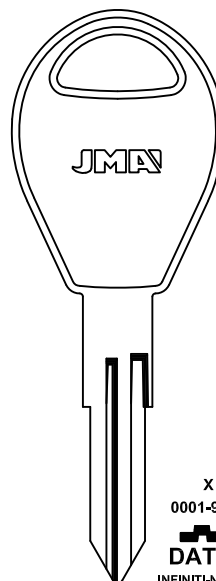

X  
0001-9000  
  
DAT-10

INFINITI-NISSAN



PARA-FOR:

NISSAN (J)

NISSAN

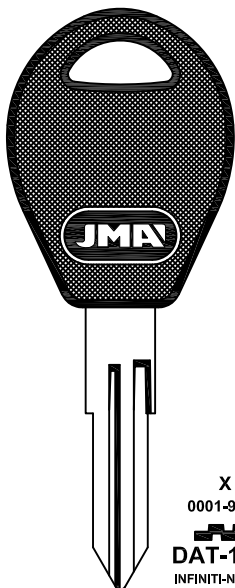

X  
0001-9000

DAT-10.P  
INFINITI-NISSAN

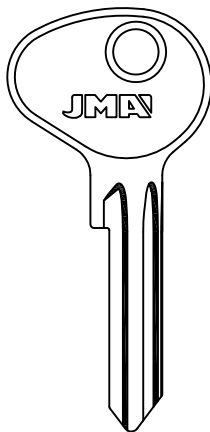

VH  
0001-3948  
K  
00001-14000

DAT-11 DAT-11D  
MAZDA-SUBARU  
DATSUN-WASO

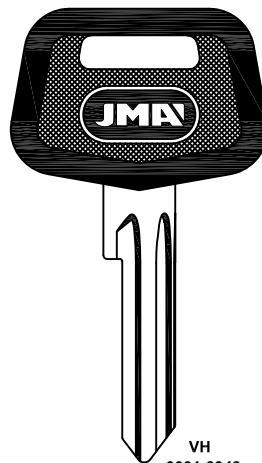

VH  
0001-3948  
K  
00001-14000

DAT-11.P DAT-11D.P  
MAZDA-SUBARU  
DATSUN-WASO

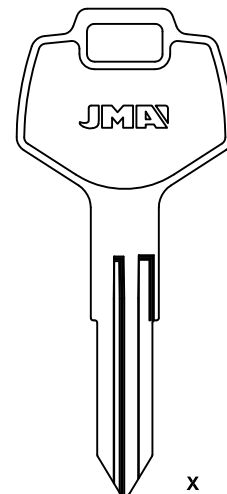

X  
0001-9000

DAT-12  
HOLDEN-NISSAN

NISSAN

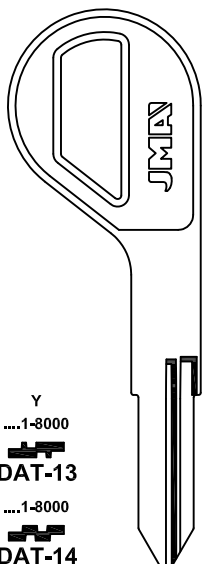

Y  
....1-8000

DAT-13

....1-8000

DAT-14

INFINITI

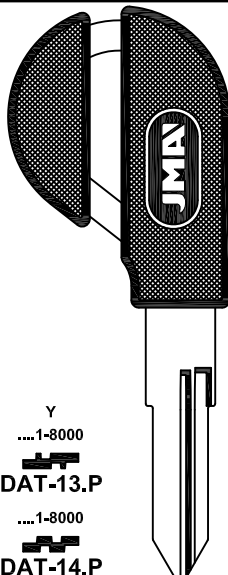

Y  
....1-8000

DAT-13.P

....1-8000

DAT-14.P

INFINITI

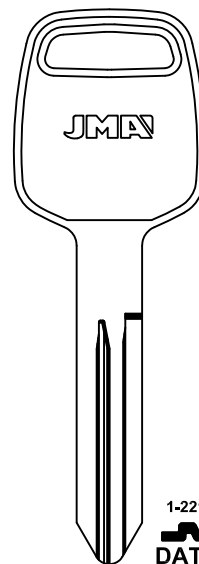

1-22185

DAT-15



....1-22185

DAT-15C1

VALEO

NISSAN



....1-22185

DAT-15C2

VALEO

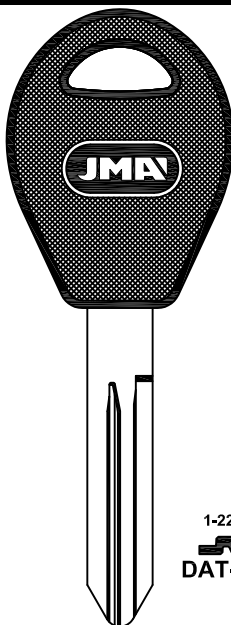

1-22185

DAT-15.P

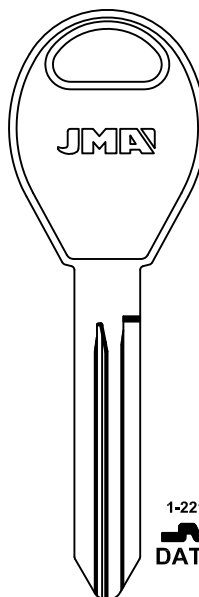

1-22185

DAT-16

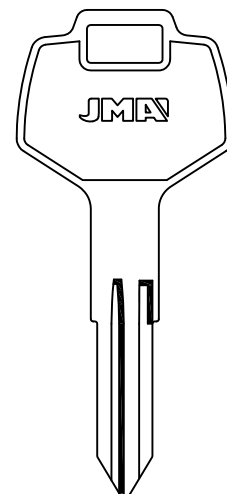

DAT-17

DAT-17D



# NISSAN

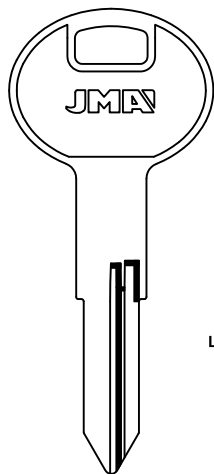

LAT.  
DAT-18

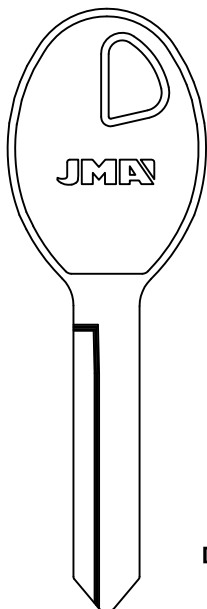

A  
101-291  
501-579  
B  
101-332  
501-602  
C  
101-344  
501-624  
D  
101-327  
501-602  
E  
101-296  
501-579  
DAT-19

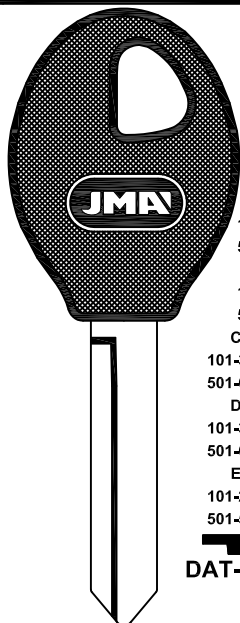

A  
101-291  
501-579  
B  
101-332  
501-602  
C  
101-344  
501-624  
D  
101-327  
501-602  
E  
101-296  
501-579  
DAT-19.P

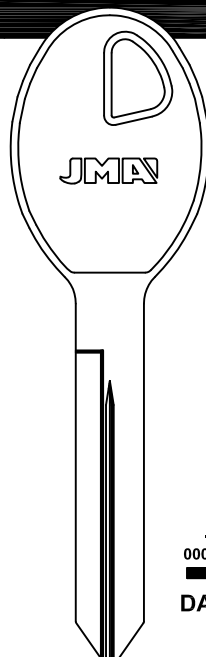

....X  
0001-1706  
DAT-20

# PARA-FOR:

NISSAN (J)

PGO (J)

PJ (F)

# NISSAN

# PGO

# PJ

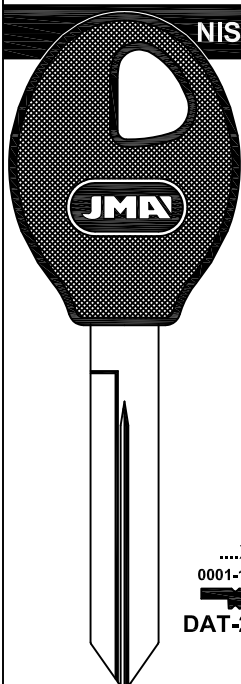

....X  
0001-1706  
DAT-20.P

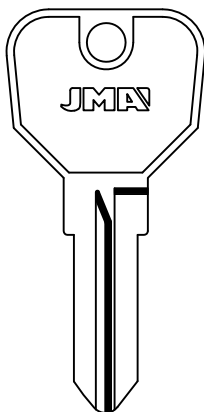

PGO-1

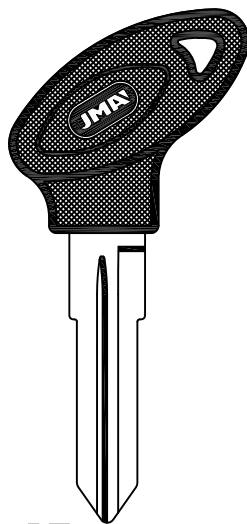

PGO-2.P

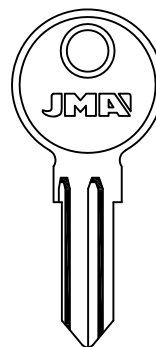

J...  
001-224  
PJ-1

DAF-RENAULT-TALBOT S.-VOLKSWAGEN  
KIFERM

# PJ

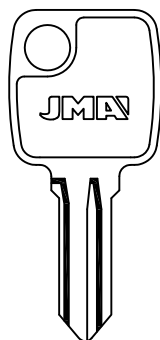

J...  
001-224  
PJ-2

KIFERM

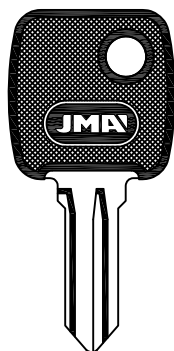

J...  
001-224  
PJ-2.P

KIFERM

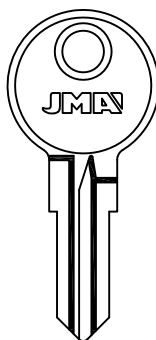

K....4-6-8  
K....4-6-8-A-B-C  
G..01-99

PJ-3

TALBOT SIMCA

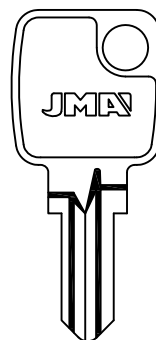











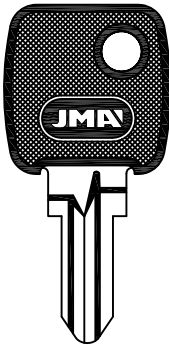

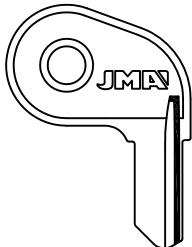

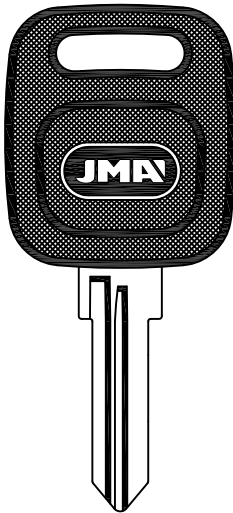

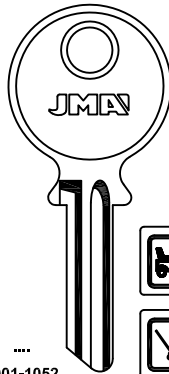



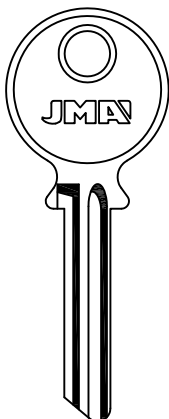

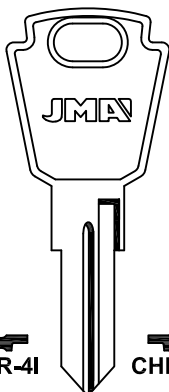





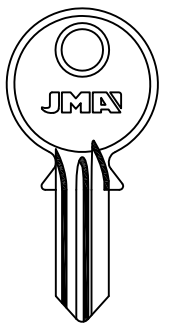



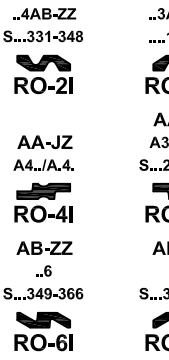











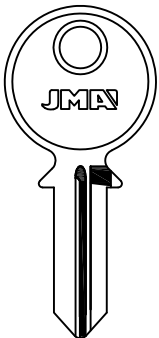

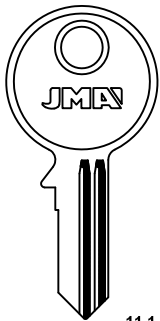

K....4-6-8  
K....4-6-8-A-B-C

PJ-K

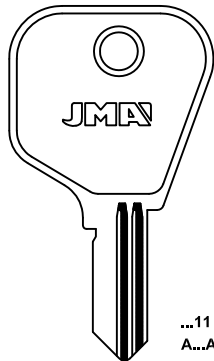

**PARA-FOR:**

- PJ (F)
- POLLAK (USA)
- POS (D)
- PRESTA (D)
- RONIS (F)

| PJ  | POLLAK  | POS   | PRESTA   |
|---|---|---|--|
| <br><br>K....4-6-8<br>K....4-6-8-A-B-C<br><br>PJ-K.P                         | <br><br>PLL-1<br>ERINRUDE   | <br><br>POS-1D.P<br>SISPA  | <br><br><br>....<br>1001-1052<br>....<br>7200-7399<br><br>PRE-1I<br><br>PRE-3<br>FIAT IVECO-MAGIRUS DEUTZ<br>LAPORTE  |
| PRESTA  | RONIS   |   |  |
| <br><br>...7700-7749<br><br>PRE-2I<br>LAPORTE                           | <br><br>CHR-4I<br><br>RO-1IS<br><br><br>CHR-4D<br><br>RO-1DS<br>C<br>001-224<br><br>RO-3 | <br><br>A8..AA-DS<br>..8AB-ZZ<br>S...385-402<br><br>RO-1I<br><br><br>A9..AA-DS<br>..8AB-ZZ<br>S...403-420<br><br>RO-1D<br>CITROEN-PEUGEOT-RENAULT-TALBOT<br>ABSA-FROSER-PJ-SADV   | <br><br>..4AB-ZZ<br>S...331-348<br><br>RO-2I<br><br><br>AA-JZ<br>A4..A.A.4.<br><br>RO-4I<br><br><br>AB-ZZ<br>..6<br>S...349-366<br><br>RO-6I<br><br><br>..3AB-ZZ<br>...1 AL 4<br><br>RO-2D<br><br><br>AA-JZ<br>A3..A.A.3.<br>S...213-246<br><br>RO-4D<br><br><br>AB-ZZ<br>..7<br>S...367-384<br><br>RO-6D |
| RONIS   |   |   |  |
| <br><br>C4..AA-ZY<br>D4..AA-HR<br><br>RO-5I<br>CITROEN-PEUGEOT<br>ABSA | <br><br>...151-700<br>E...1-1000<br>T...107-400<br>Y...101-600<br><br>RO-7I<br><br><br>C3..AA-ZY<br>D3..AA-HR<br>J...1-544<br><br>RO-5D<br>ALFA ROMEO-RENAULT              | <p>ARMOR<br/>EMHART<br/>FORINDEX<br/>KARDEX<br/>MLM<br/>NEMEF<br/>RONEO<br/>SANEL STRAFOR<br/>SCHAFER<br/>YAC</p> <br>RO-8I<br><br><br>RO-30<br><br><br>RO-32D<br><br><br>RO-8D<br><br><br>RO-30D<br><br><br>RO-33 | <br><br>...151-700<br>E...1-1000<br>T...107-400<br>Y...101-600<br><br>RO-11I<br>PEUGEOT-RENAULT<br>ABSA-SADV-SIMPLEX  |



## RONIS

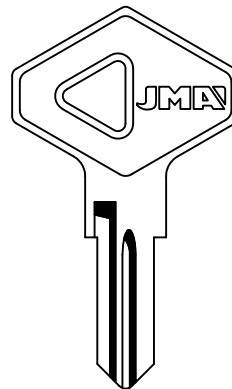
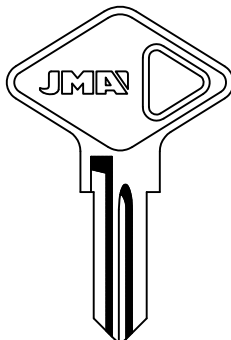
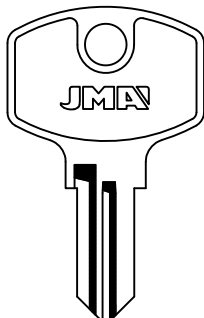
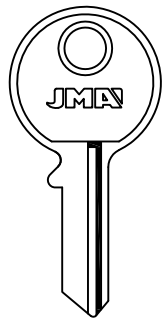

RO-12I

RO-12D

M...601-983

TAV

RO-16I

RO-16D

RO-14

PEUGEOT

70.....  
1 AL 3  
...1-975

RO-15

ACN-ARO DACIA-RENAULT

77....  
0 AL 3

RO-17

RENAULT

BURG-STRAFOR

## PARA-FOR:

RONIS (F)

ROSS (E)

SAAB (S)

SAFE (I)

## ROSS

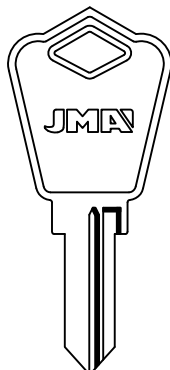
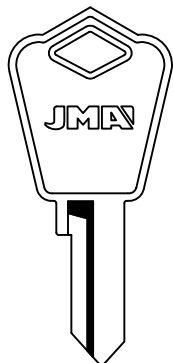

ROS-1D

ROS-2

## SAAB

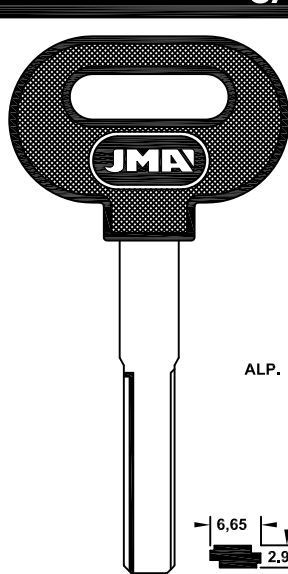

ALP.

6,65  
2,9

SAAB  
YMOS

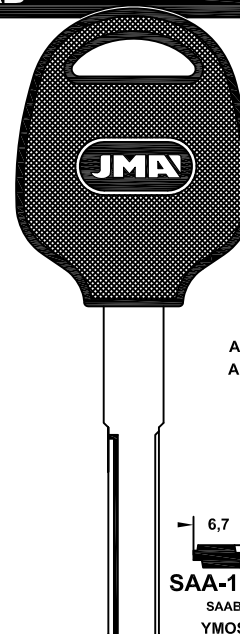

ALP.  
ACE.

6,7  
2,95

SAA-1.P1  
SAAB  
YMOS

## SAAB

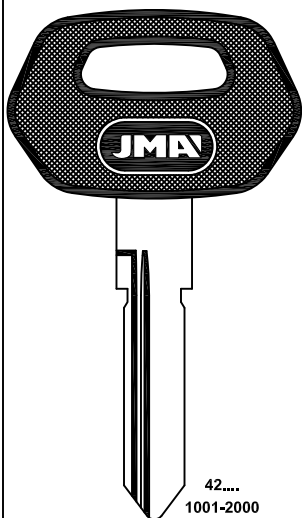

42....  
1001-2000  
SAA-2.P

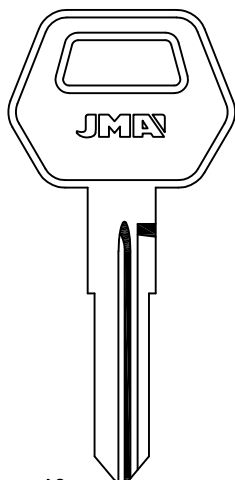

AC  
1-3192  
SAA-AC

SAAB  
YMOS

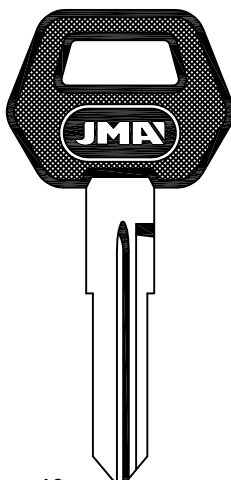

AC  
1-3192  
SAA-AC.P

SAAB  
YMOS

## SAFE

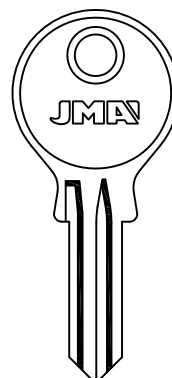

15-I 15-D

TRAMA-FIST



**PARA-FOR:**

SAFE (I)

SIMPLEX (F)

**SAFE**

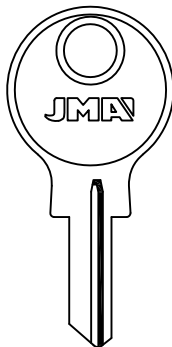

16-I

16-D

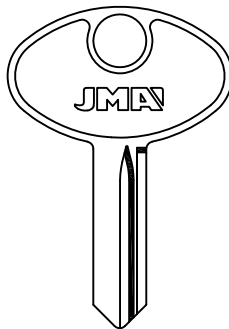

A  
001-125  
AF-1I

ALFA ROMEO-AUTOBIANCHI  
SIPEA-MAGNETI MARELLI

B  
001-125  
AF-1D

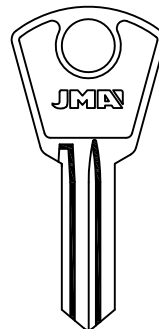

D  
1-125  
AF-2I

ALFA ROMEO-AUTOBIANCHI  
SIPEA-MAGNETI MARELLI

C  
1-125  
AF-2D

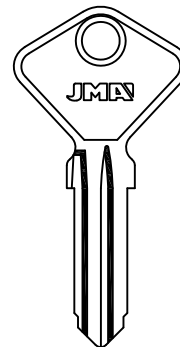

AF-3I

AF-3D

**SAFE**

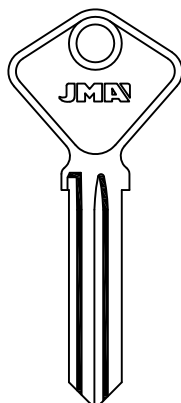

S  
615-699  
712-799  
812-899  
AF-4I

ALFA ROMEO-FIAT  
FIST-TRAMA

D  
115-199  
212-299  
312-399  
AF-4D

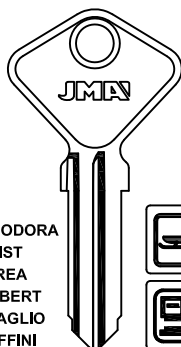

CROMODORA  
FIST  
FREA  
GIOBERT  
MIRAGLIO  
RUFFINI

6  
100-309  
AF-5I

2  
100-309  
AF-6I

ALFA ROMEO-AUTOBIANCHI-FIAT



8  
100-309  
AF-5D

4  
100-309  
AF-6D

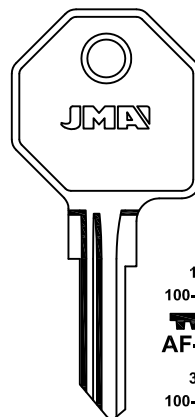

1  
100-789  
AF-10

3  
100-789  
AF-11

5  
100-789  
AF-12

ALFA-INNOCENTI-LANCIA-MASERATI

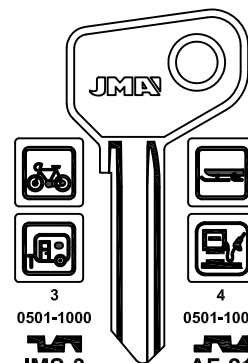

3  
0501-1000  
IMS-3

1  
0501-1000  
IMS-5

IMS-13

BLOSTER  
CROMODORA-FIST-JMSA



4  
0501-1000  
AF-2I

2  
0501-1000  
AF-19

**SAFE**

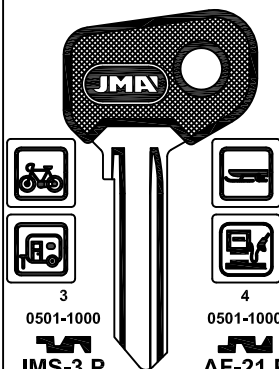

3  
0501-1000  
IMS-3.P

1  
0501-1000  
IMS-5.P

IMS-13.P

BLOSTER  
CROMODORA-FIST-JMSA



4  
0501-1000  
AF-21.P

2  
0501-1000  
AF-19.P

**SIMPLEX**

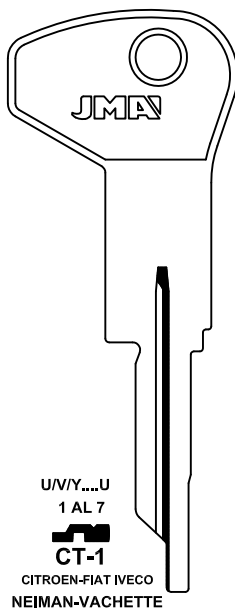

UV/Y...U  
1 AL 7  
CT-1

CITROEN-FIAT IVECO  
NEIMAN-VACHETTE

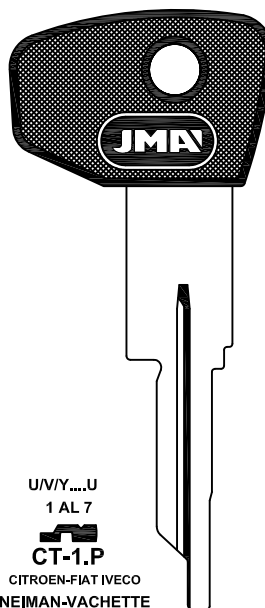

UV/Y...U  
1 AL 7  
CT-1.P

CITROEN-FIAT IVECO  
NEIMAN-VACHETTE

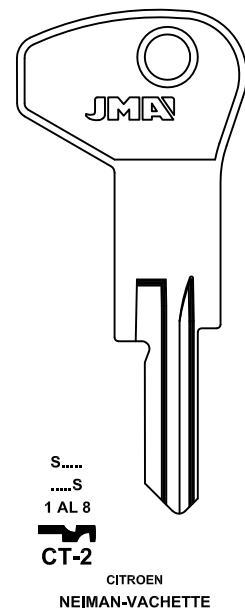

S...S  
1 AL 8  
CT-2

CITROEN  
NEIMAN-VACHETTE





## SIMPLEX

PARA-FOR:  
SIMPLEX (F)

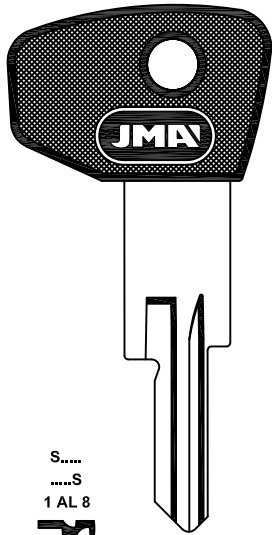

S.....  
.....S  
1 AL 8

CT-2.P

CITROEN

NEIMAN-VACHETTE

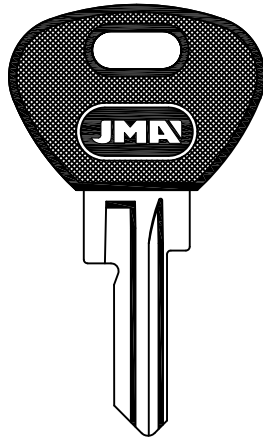

S.....  
.....S  
1 AL 8

CT-2.P1

CITROEN

NEIMAN-VACHETTE

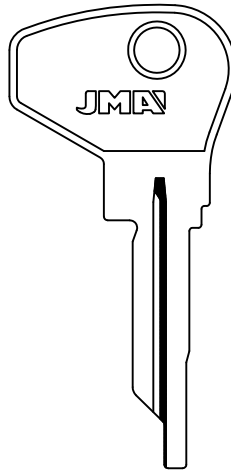

B-T.....T  
1 AL 7

CT-3

CITROEN-MASERATI-FIAT IVECO

NEIMAN-VACHETTE

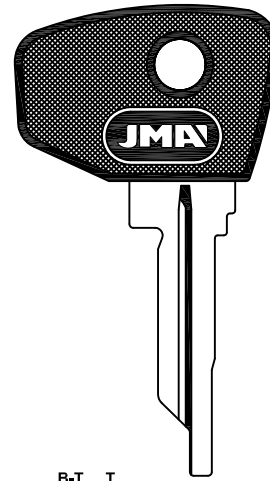

B-T.....T  
1 AL 7

CT-3.P

CITROEN-MASERATI-FIAT IVECO

NEIMAN-VACHETTE

## SIMPLEX

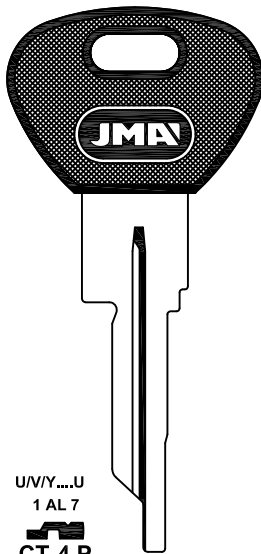

U/V/Y.....U  
1 AL 7

CT-4.P

CITROEN-FIAT IVECO

NEIMAN-VACHETTE

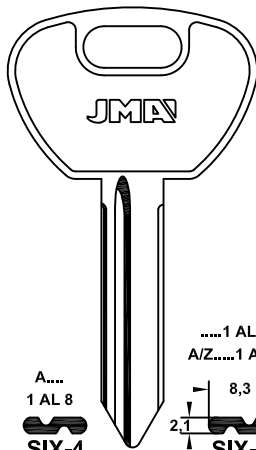

A.....  
1 AL 8  
SIX-4

.....1 AL 8  
A/Z.....1 AL 8

8,3  
2,1  
SIX-1

CITROEN-PEUGEOT

NEIMAN

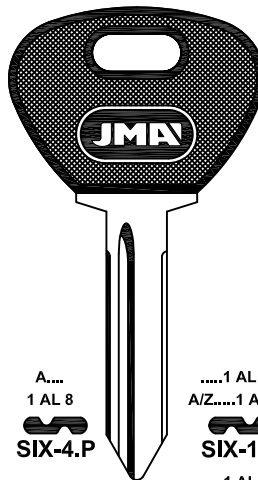

A.....  
1 AL 8  
SIX-4.P

.....1 AL 8  
A/Z.....1 AL 8

SIX-1.P

CITROEN-PEUGEOT

NEIMAN

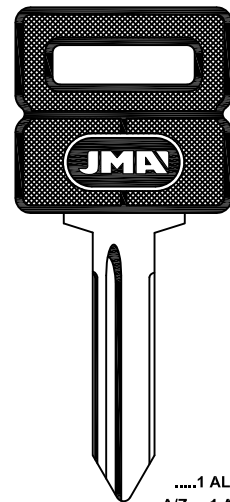

.....1 AL 8  
A/Z.....1 AL 8

SIX-1.P1

CITROEN-PEUGEOT

NEIMAN

## SIMPLEX

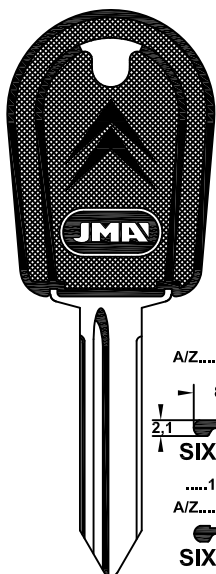

A/Z.....1 AL 8

8,3  
2,1  
SIX-1.P2

.....1 AL 8  
A/Z.....1 AL 8

SIX-2.P2

CITROEN

NEIMAN

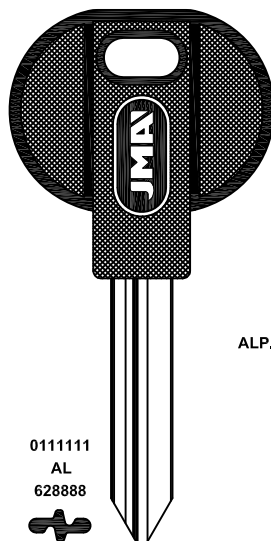

0111111  
AL  
628888

SIX-3.P

CITROEN

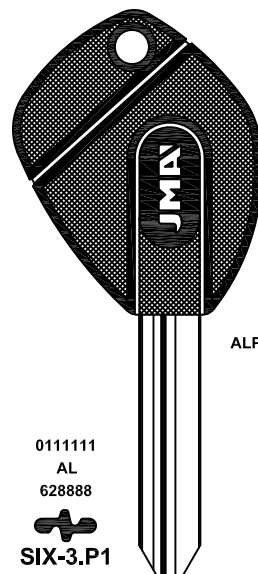

ALP.

0111111  
AL  
628888

SIX-3.P1

CITROEN-FIAT-LANCIA-PEUGEOT

ALP.

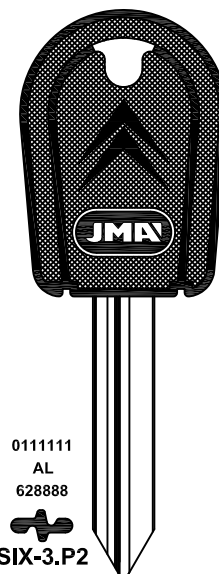

0111111  
AL  
628888

SIX-3.P2

CITROEN

ALP.



**PARA-FOR:**









SIMPLEX (F)

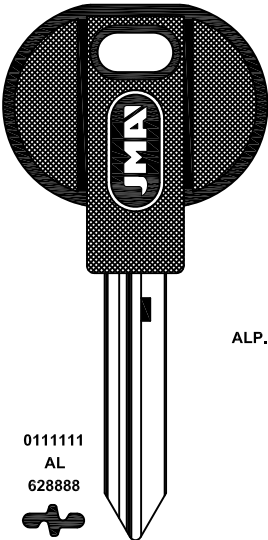
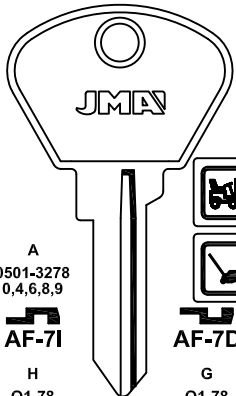

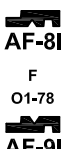
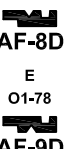
SIPEA (I)

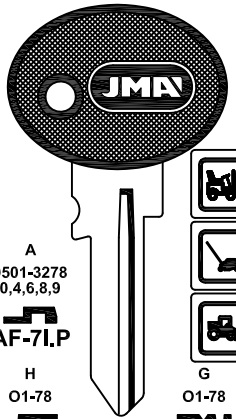



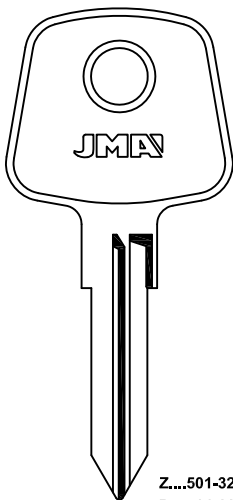
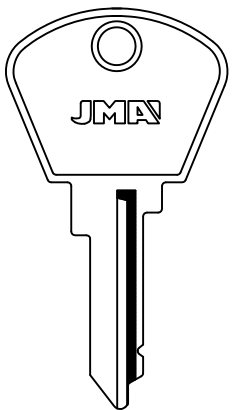
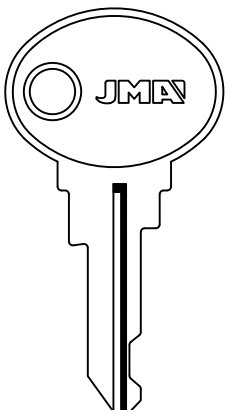
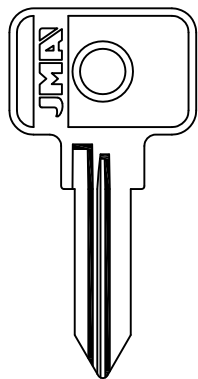

SISPA (I)

SSANGYONG

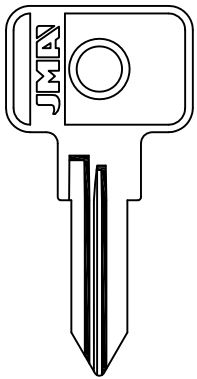
(K)

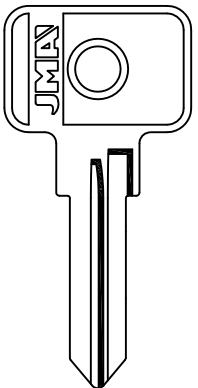
| SIMPLEX   | SIPEA  |   |   |
|---|--|---|---|
|  <p>0111111<br/>AL<br/>628888<br/>SIX-5.P</p> <p>CITROEN</p> |  <p>A<br/>0501-3278<br/>0,4,6,8,9<br/>AF-7I</p>  <p>G<br/>01-78<br/>AF-7D</p>  <p>H<br/>01-78<br/>AF-8I</p>  <p>G<br/>01-78<br/>AF-8D</p>  <p>F<br/>01-78<br/>AF-9I</p> <p>E<br/>01-78<br/>AF-9D</p> <p>ALFA-AUTOBIANCHI-FIAT-LANCIA<br/>SAFE</p> |  <p>A<br/>0501-3278<br/>0,4,6,8,9<br/>AF-7I.P</p>  <p>H<br/>01-78<br/>AF-8I.P</p>  <p>F<br/>01-78<br/>AF-9I.P</p> <p>E<br/>01-78<br/>AF-9D.P</p> <p>ALFA-AUTOBIANCHI-FIAT-LANCIA<br/>SAFE</p> |  <p>A<br/>0501-3278<br/>0,4,6,8,9<br/>AF-7I.P1</p> <p>FERRARI-FIAT-LAMBORGHINI-MASERATI<br/>NEIMAN</p> |

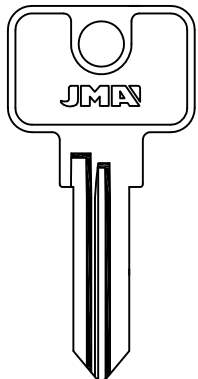
| SIPEA   |  |   | SISPA  |
|---|--|---|--|
|  <p>Z....501-3278<br/>P....501-3278<br/>SIP-1</p> <p>OM IVECO-YUGO ZASTAVA-FIAT IVECO</p> |  <p>....4-6-8-9<br/>SIP-2</p> <p>FIAT-PREMIER<br/>MAGNETI MARELLI-NEIMAN</p> |  <p>B....501-3278<br/>B....0-4-6-8-9<br/>SIP-3</p> <p>A.ROMEO-AUTOBIANCHI-FIAT-LANCIA<br/>ARTEB-CLAUSOR-NEIMAN</p> |   <p>....1100-1307<br/>SI-1D</p> <p>AUTOBLOCK</p> |

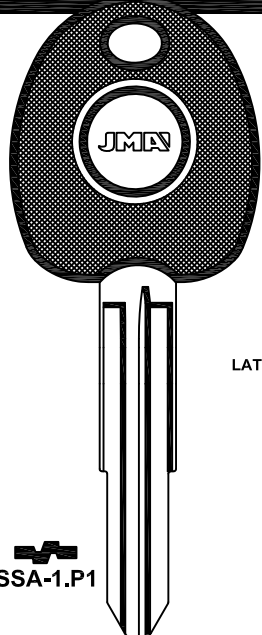
| SISPA   |  |  | SSANGYONG   |
|---|--|--|---|
|   <p>1...<br/>SI-2D</p> <p>SI-3      SI-3D</p> <p>AUTOBLOCK</p> |   <p>....1100-1307</p> <p>SI-4      SI-4D</p> <p>AUTOBLOCK</p> |   <p>SI-5D</p> <p>AUTOBLOCK</p> |  <p>LAT.</p> <p>SSA-1.P1</p> |



**STREBOR**

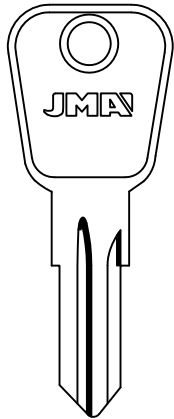

SF...101-199  
SR...301-399  
SS...201-299  
SO...01-99



**STR-3**  
UNION

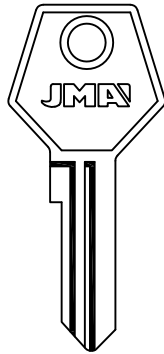

S..1-70



**STR-4**

**STS**

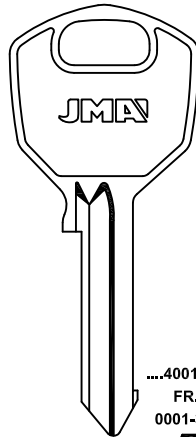

...4001-6000  
FR...  
0001-3040



**STS-2D**



**STS-5D**

EBRO-NISSAN  
BLOCK-DOM

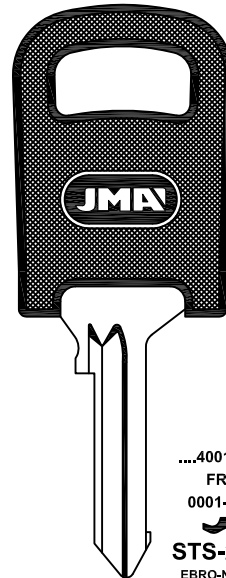

...4001-6000  
FR...  
0001-3040



**STS-2D.P**

EBRO-NISSAN  
BLOCK-DOM

**PARA-FOR:**  
STREBOR (GB)  
STS (E)  
SUBARU (J)  
SUZUKI (J)

**STS**

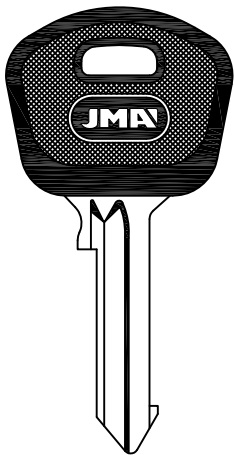

**STS-5D.P**  
EBRO-NISSAN  
DOM

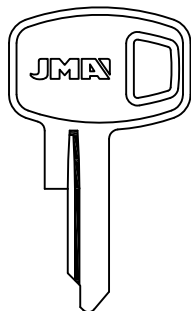

**STS-11**  
PIAGGIO

**SUBARU**

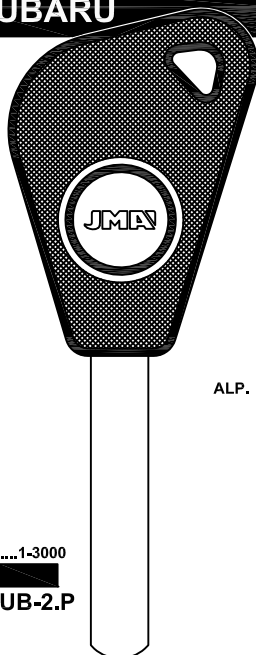

ALP.

T...1-3000



**SUB-2.P**

**SUZUKI**

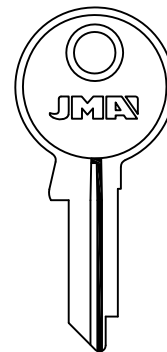

**SUZU-1I**



**SUZU-2I**



**SUZU-1D**



**SUZU-2D**

**SUZUKI**

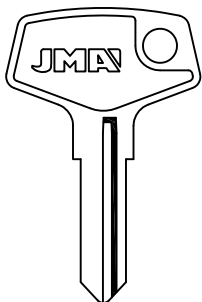

**SUZU-3I**  
SUZUKI

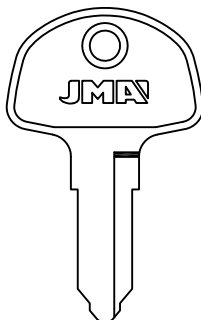

**SUZU-4I**

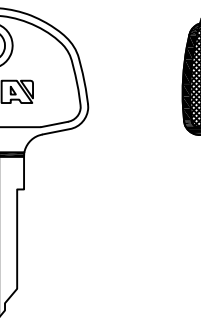

**SUZU-4D**

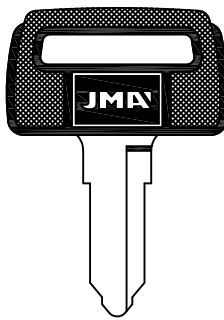

**SUZU-4I.P**



**SUZU-4D.P**

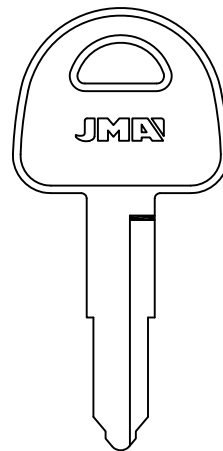

**SUZU-5**  
BIMOTA-SUZUKI

...  
101-499  
751-795  
A00-A99

...  
101-499  
751-795  
A00-A99

...  
101-499  
751-795

BIMOTA-CAGIVA-HONDA-KAWASAKI  
LAVERDA-AUGUSTA-PEUGEOT-SUZUKI



PARA-FOR:

SUZUKI (J)

SUZUKI

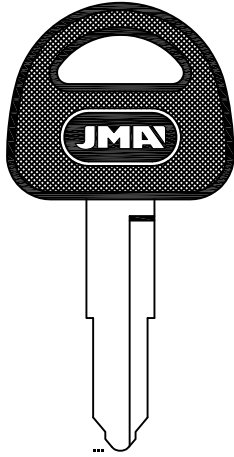

...  
101-499  
751-795  
  
**SUZU-5.P**  
BIMOTA-SUZUKI

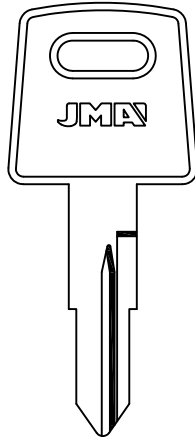

A  
001-133  
  
**SUZU-6**

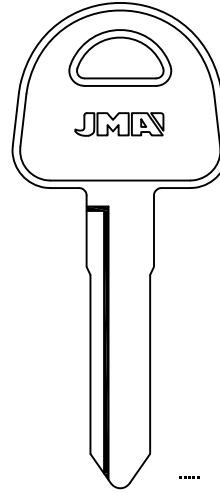

.....  
16501-17704  
  
**SUZU-7**  
GM-MARUTI-SUZUKI



.....  
16501-17704  
  
**SUZU-7.P** **SUZU-7D.P**  
GM-MARUTI-SUZUKI

SUZUKI

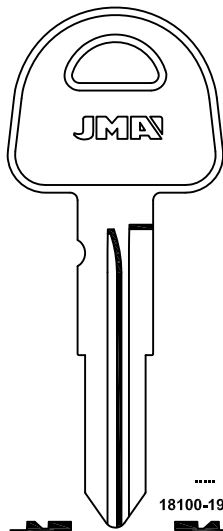

.....  
18100-19229  
  
**SUZU-8I** **SUZU-8**  
SUZUKI

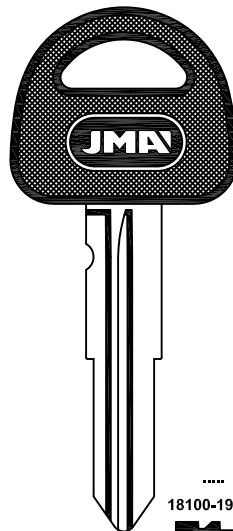

.....  
18100-19229  
  
**SUZU-8.P**  
SUZUKI

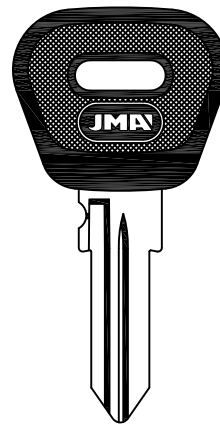

.....1 AL 5  
  
**SUZU-9.P**  
SUZUKI  
CLAUSOR

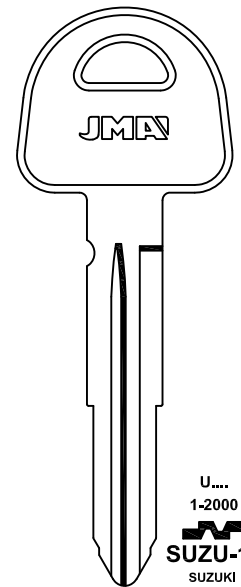

U....  
1-2000  
  
**SUZU-10**  
SUZUKI

SUZUKI

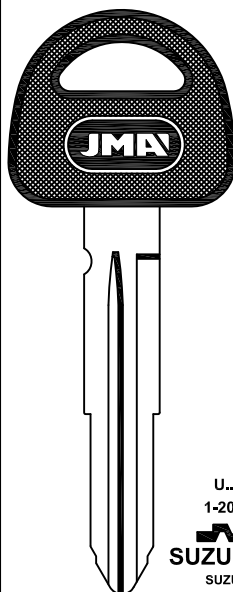

U....  
1-2000  
  
**SUZU-10.P**  
SUZUKI

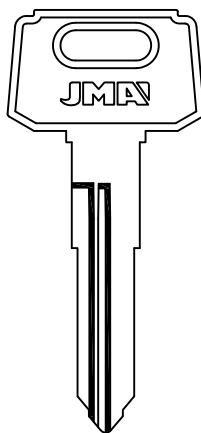

....  
6001-7000  
  
**SUZU-11D**  
SUZUKI

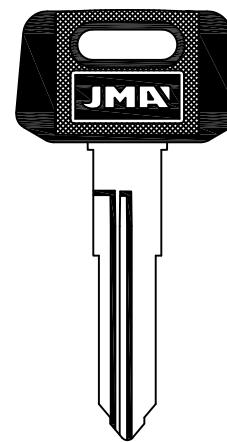

....  
6001-7000  
  
**SUZU-11D.P**  
SUZUKI

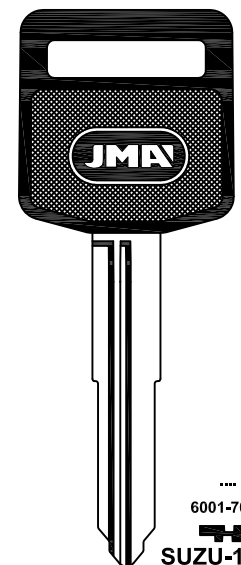

....  
6001-7000  
  
**SUZU-12D.P**  
SUZUKI



**SUZUKI**

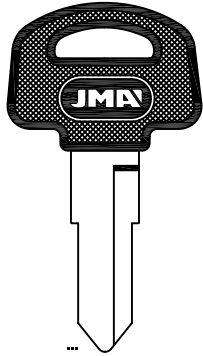

...  
101-499  
751-795  
A00-A99  
**SUZU-13.P**

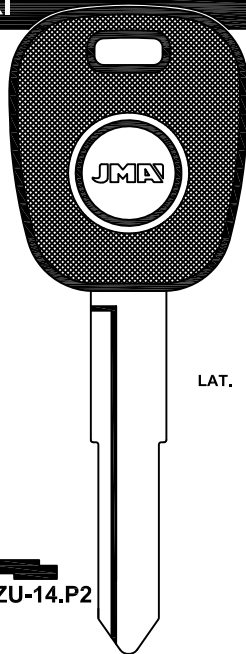

**SUZU-14.P2**

**SUZU-13D.P**  
BIMOTA-CAGIVA-HONDA-KAWASAKI  
LAVERDA-AUGUSTA-PEUGEOT-SUZUKI

**TAP-AGIS**

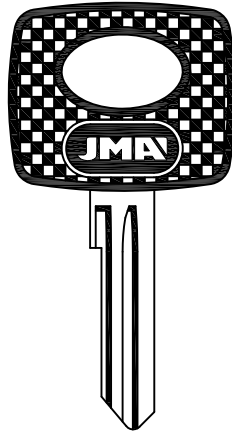

**TAP-1P**

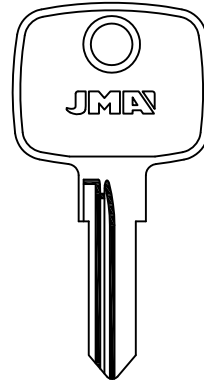

**TAP-2**

**PARA-FOR:**

- SUZUKI (J)
- TAP-AGIS (YU)
- TATA (IND)
- TECUMSEH (A)
- TIBBE (D)
- TITAN (SLO)
- TOOL BOX (USA)

**TATA**

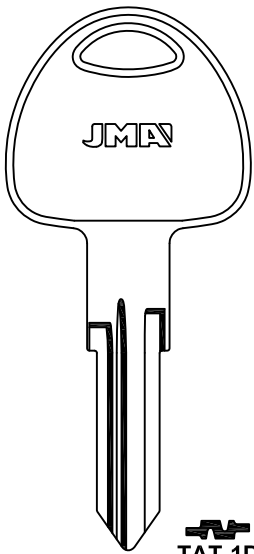

**TAT-1D**



**TAT-1D.P**

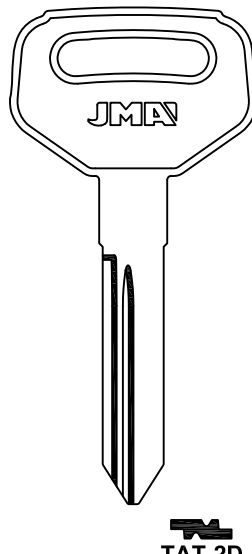

**TAT-2D**

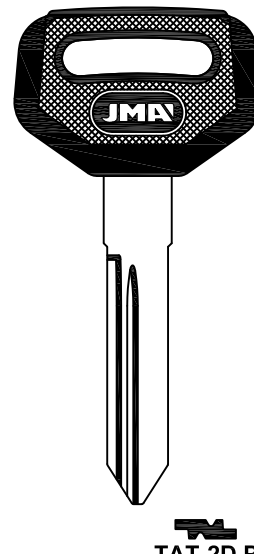

**TAT-2D.P**

**TECUMSEH**

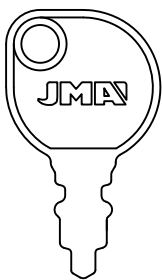

6,2 1,82  
**TEU-1**

INDAK

**TIBBE**

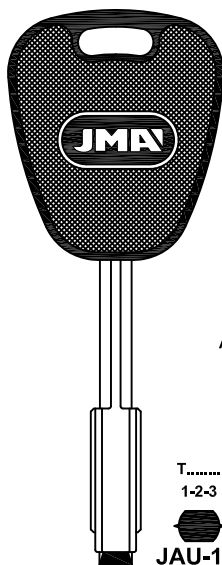

ALP.

T.....  
1-2-3  
**JAU-1.P**

**TITAN**

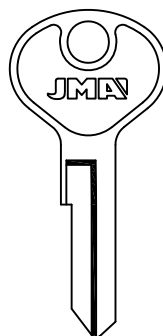

**TIT-7D**

**TOOL BOX**

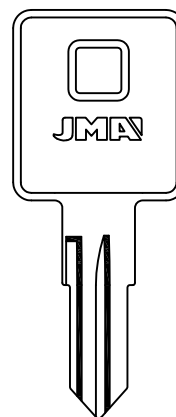





LAT.

**TOO-1D**

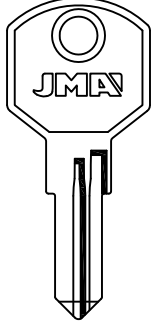
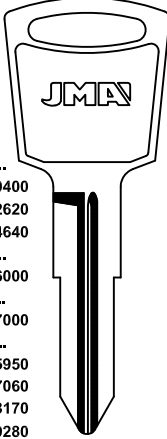
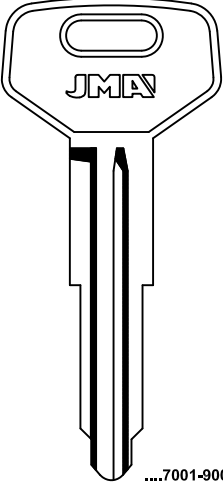
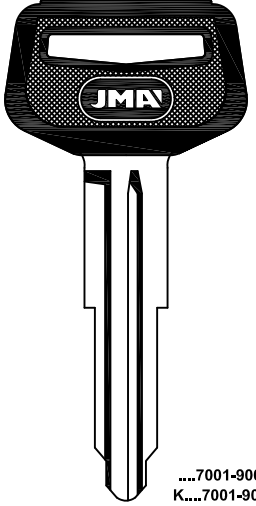

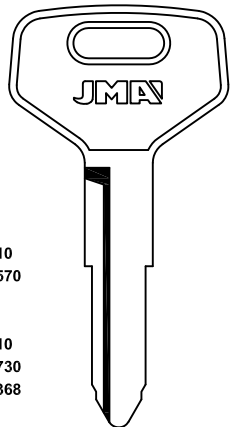
PARA-FOR:  
TOOL BOX (USA)  
TOYOTA (J)

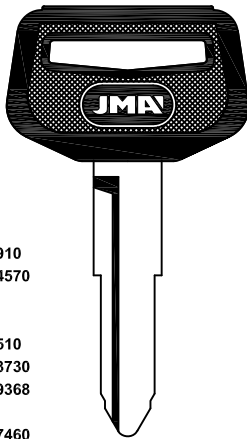
| TOOL BOX  | TOYOTA   |  |   |
|---|--|--|---|
|  <p>LAT.</p> <p><b>TOO-2</b></p> | <p>A....<br/>0001-0400<br/>2221-2620<br/>4441-4640<br/>B....<br/>5001-6000<br/>C....<br/>6001-7000<br/>M....<br/>5551-5950<br/>6661-7060<br/>7771-8170<br/>8814-9280<br/>N....<br/>1921-2220</p>  <p><b>TOYO-2</b><br/>GM-TOYOTA<br/>TOKAJ-RIKA</p> |  <p>....7001-9000<br/>K....7001-9000</p> <p><b>TOYO-3</b><br/>DAIHATSU-TOYOTA<br/>TOKAJ-RIKA</p> |  <p>....7001-9000<br/>K....7001-9000</p> <p><b>TOYO-3.P</b><br/>DAIHATSU-TOYOTA<br/>TOKAJ-RIKA</p> |

| TOYOTA  |   |   |   |
|---|---|---|---|
|  <p>K....<br/>001-400/1511-1910<br/>2221-2620/3731-4570<br/>5001-6368<br/>R....<br/>401-800/1112-1510<br/>2621-3020/3331-3730<br/>5001-6924/8001-9368<br/>S....<br/>5951-6350/7061-7460<br/>8171-8570/9281-9680<br/>D....<br/>6001-7042</p> <p><b>TOYO-K1</b><br/>BEDFORD-DAIHATSU-D.MOTOR-HOLDEN-HYUNDAI-SUZUKI-LOTUS-SUZUKI-HINO<br/>TOKAJ-RIKA</p> |  <p>F....<br/>5951-6350<br/>7061-7460<br/>8171-8570<br/>9281-9680<br/>P....<br/>7001-8500</p> <p><b>TOYO-4</b><br/>C....<br/>6001-7042</p> <p><b>TOYO-14</b><br/>TOKAJ-RIKA</p> |  <p>K....<br/>001-400/1511-1910<br/>2221-2620/3731-4570<br/>5001-6368<br/>R....<br/>401-800/1112-1510<br/>2621-3020/3331-3730<br/>5001-6924/8001-9368<br/>S....<br/>5951-6350/7061-7460<br/>8171-8570/9281-9680<br/>D....<br/>6001-7042</p> <p><b>TOYO-K1.P</b><br/>BEDFORD-DAIHATSU-D.MOTOR-HOLDEN-HYUNDAI-SUZUKI-LOTUS-SUZUKI-HINO<br/>TOKAJ-RIKA</p> |  <p>F....<br/>5951-6350<br/>7061-7460<br/>8171-8570<br/>9281-9680<br/>P....<br/>7001-8500</p> <p><b>TOYO-4.P</b><br/>C....<br/>6001-7042</p> <p><b>TOYO-14.P</b><br/>TOKAJ-RIKA</p> |

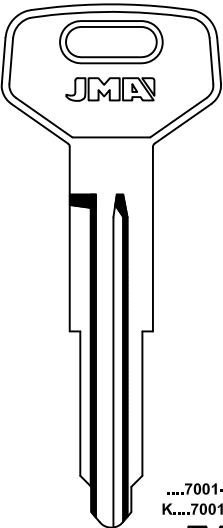
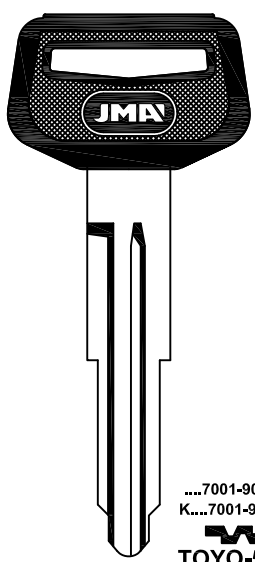
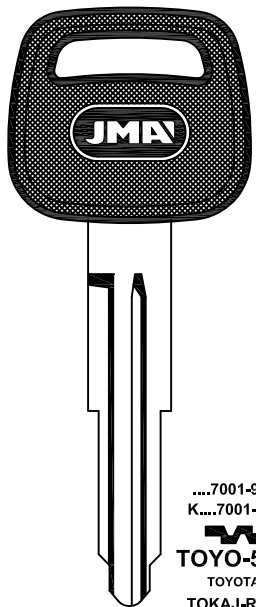
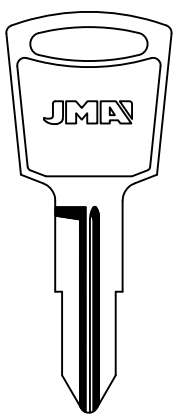
| TOYOTA   |  |  |   |
|--|--|--|---|
|  <p>....7001-9000<br/>K....7001-9000</p> <p><b>TOYO-5</b><br/>TOYOTA<br/>TOKAJ-RIKA</p> |  <p>....7001-9000<br/>K....7001-9000</p> <p><b>TOYO-5.P</b><br/>TOYOTA<br/>TOKAJ-RIKA</p> |  <p>....7001-9000<br/>K....7001-9000</p> <p><b>TOYO-5.P1</b><br/>TOYOTA<br/>TOKAJ-RIKA</p> |  <p><b>TOYO-6</b><br/>TOKAJ-RIKA</p> |



**TOYOTA**

**PARA-FOR:**

TOYOTA (J)

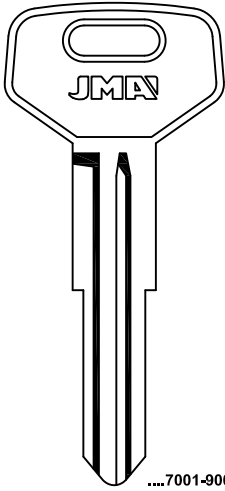

....7001-9000  
K....7001-9000



**TOYO-8**

DAIHATSU-TOYOTA  
TOKAJ-RIKA

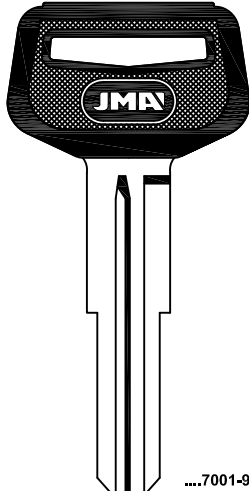

....7001-9000  
K....7001-9000



**TOYO-8LP**

DAIHATSU-TOYOTA  
TOKAJ-RIKA

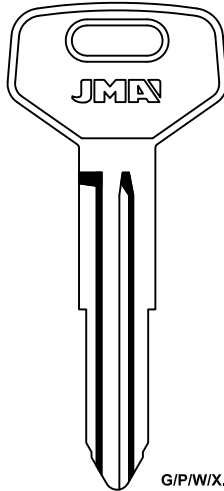

G/P/W/X....  
1-2000



**TOYO-9**

TOYOTA-VOLKSWAGEN  
TOKAJ-RIKA

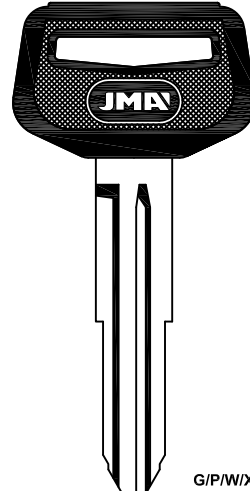

G/P/W/X....  
1-2000



**TOYO-9.P**

TOYOTA-VOLKSWAGEN  
TOKAJ-RIKA

**TOYOTA**

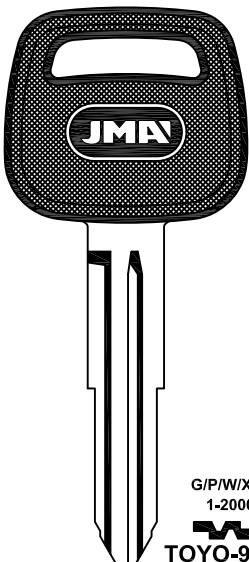

G/P/W/X....  
1-2000



**TOYO-9.P1**

TOYOTA-VOLKSWAGEN  
TOKAJ-RIKA

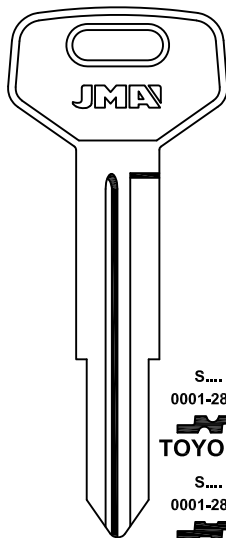

S....  
0001-2878



**TOYO-10**

S....  
0001-2878



**TOYO-11**

TOYOTA  
TOKAJ-RIKA

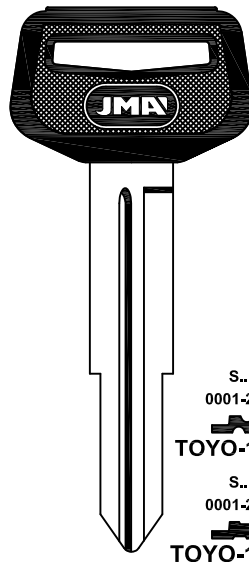

S....  
0001-2878



**TOYO-10.P**

S....  
0001-2878



**TOYO-11.P**

TOYOTA  
TOKAJ-RIKA

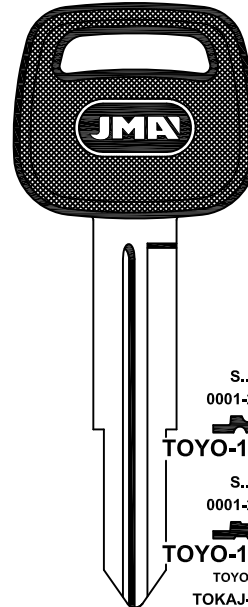

S....  
0001-2878



**TOYO-10.P1**

S....  
0001-2878



**TOYO-11.P1**

TOYOTA  
TOKAJ-RIKA

**TOYOTA**

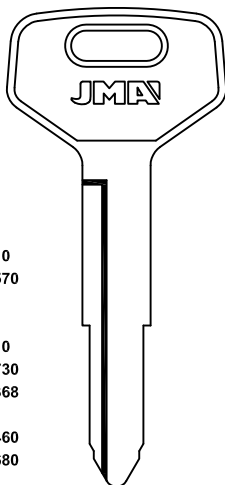

K....  
001-400/1511-1910  
2221-2620/3731-4570  
5001-6368

R....  
401-800/1112-1510  
2621-3020/3331-3730  
5001-6924/8001-9368

S....  
5951-6350/7061-7460  
8171-8570/9281-9680

D....  
6001-7042



**TOYO-12**

TOYOTA  
TOKAJ-RIKA

F....  
5951-6350  
7061-7460  
8171-8570  
9281-9680



**TOYO-13**

C....  
6001-8042  
U....  
3001-4000

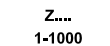

**TOYO-12D**

K....  
001-400/1511-1910  
2221-2620/3731-4570  
5001-6368

R....  
401-800/1112-1510  
2621-3020/3331-3730  
5001-6924/8001-9368

S....  
5951-6350/7061-7460  
8171-8570/9281-9680

D....  
6001-7042



**TOYO-12.P1**

TOYOTA  
TOKAJ-RIKA

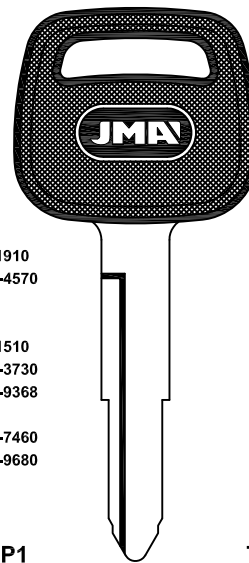

F....  
5951-6350  
7061-7460  
8171-8570  
9281-9680



**TOYO-13.P1**

C....  
6001-8042  
U....  
3001-4000



**TOYO-12D.P1**



PARA-FOR:

TOYOTA (J)

TOYOTA

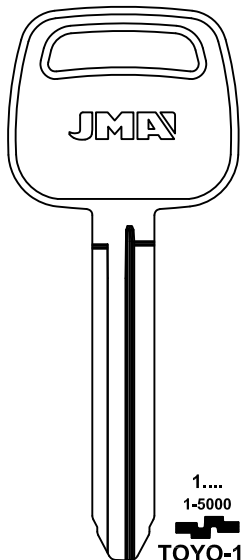

GM-TOYOTA  
TOKAJ-RIKA

1....  
1-5000

TOYO-15

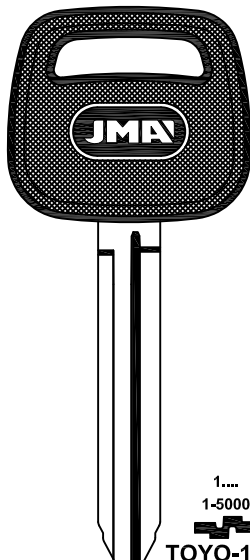

GM-TOYOTA  
TOKAJ-RIKA

1....  
1-5000

TOYO-15.P

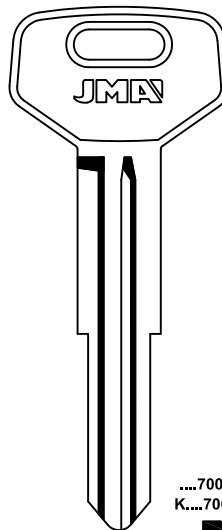

TOYOTA  
TOKAJ-RIKA

....7001-9000  
K....7001-9000

TOYO-16

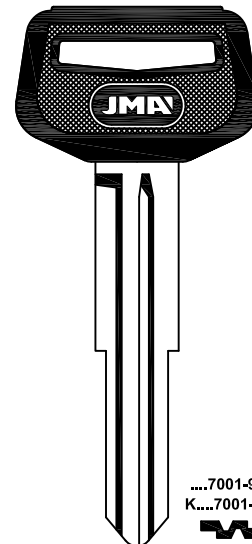

TOYOTA  
TOKAJ-RIKA

....7001-9000  
K....7001-9000

TOYO-16.P

TOYOTA

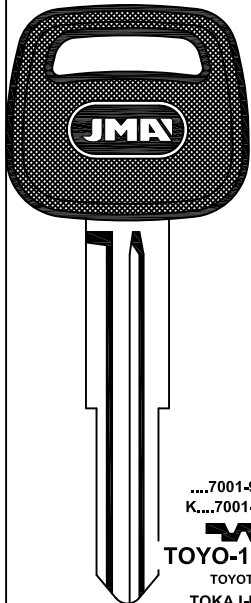

....7001-9000  
K....7001-9000

TOYO-16.P1

TOYOTA  
TOKAJ-RIKA

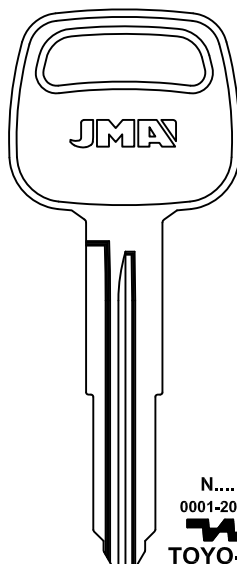

TOKAJ-RIKA

N....  
0001-2000

TOYO-17

TOYOTA

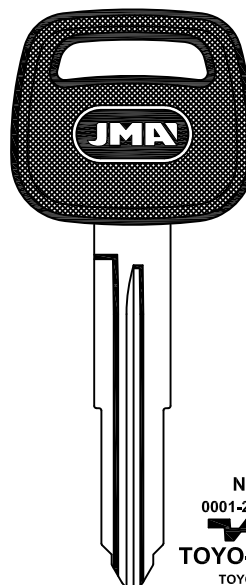

TOKAJ-RIKA

N  
0001-2000

TOYO-17.P

TOYOTA



LAT.  
1 7,8  
3

TOYO-18.P

LEXUS-MAZDA-TOYOTA  
TOKAJ-RIKA

TOYOTA

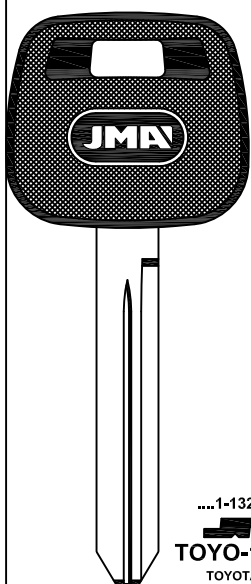

....1-13284

TOYO-19.P

TOYOTA  
VALEO

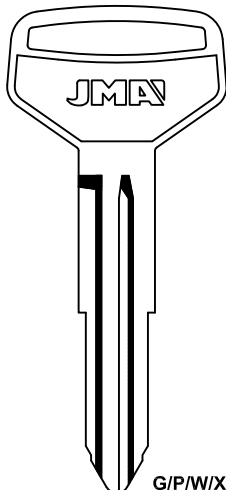

TOYOTA-VOLKSWAGEN  
TOKAJ-RIKA

G/P/W/X....  
1-2000

TOYO-20D

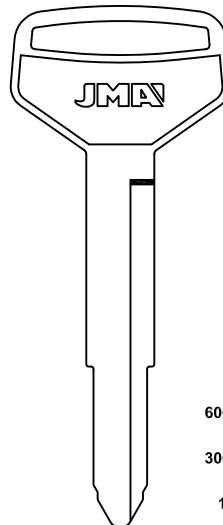

TOYOTA  
TOKAJ-RIKA

C....  
6001-8042

U....  
3001-4000

Z....  
1-1000

TOYO-22

K....  
001-400/1511-1910  
2221-2620/3731-4570  
5001-6368

R....  
401-800/1112-1510  
2621-3020/3331-3730  
5001-6924/8001-9368

S....  
5951-6350/7061-7460  
8171-8570/9281-9680

D....  
6001-7042

TOYO-22D





## TOYOTA

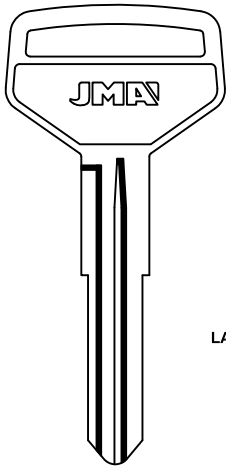

1001-2500  
3001-4500  
  
**TOYO-23**  
TOKAJ-RIKA

LAT.

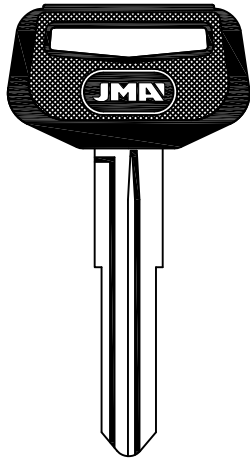

1001-2500  
3001-4500  
  
**TOYO-23.P**  
TOKAJ-RIKA

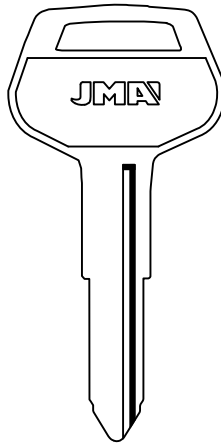

**TOYO-24**

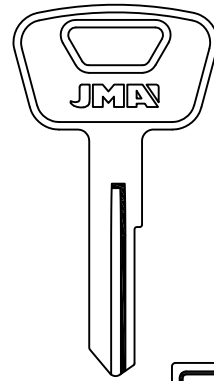

11121-15543  
51112-55424  
5....  
  
**TOYO-25**



**PARA-FOR:**  
TOYOTA (J)  
TRELOCK (D)  
TRIUMPH MOT.  
(USA)

## TOYOTA

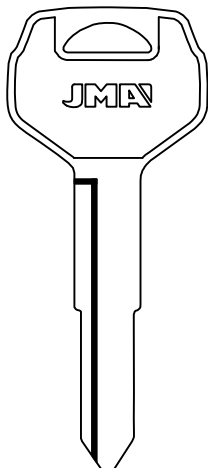

K....1-4130  
R....401-3790  
  
**TOYO-26**

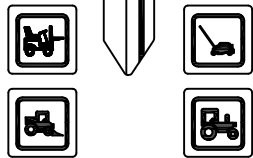
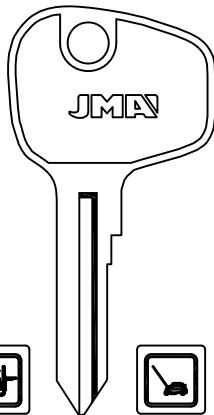

**TOYO-27**

HINO

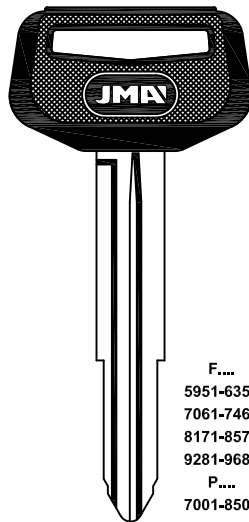

F....  
5951-6350  
7061-7460  
8171-8570  
9281-9680  
P....  
7001-8500  
  
**TOYO-28.P**

TOKAJ-RIKA

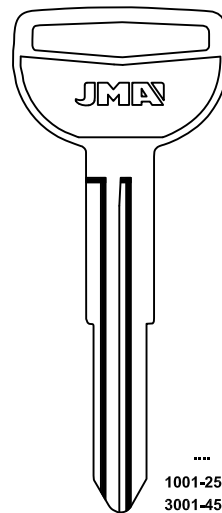

....  
1001-2500  
3001-4500  
  
**TOYO-29**

## TOYOTA



7.8  
3  
  
**TOYO-30.P1**

LAT.

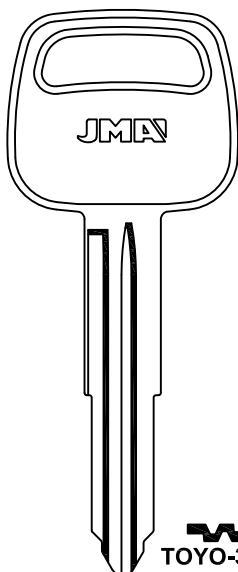

**TOYO-37D**

## TRELOCK

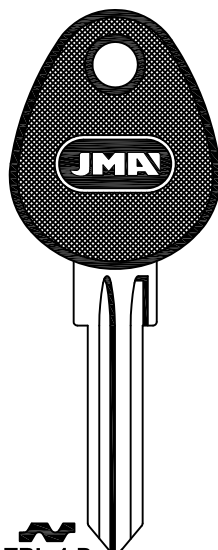

**TRL-1.P**

## TRIUMPH MOT.

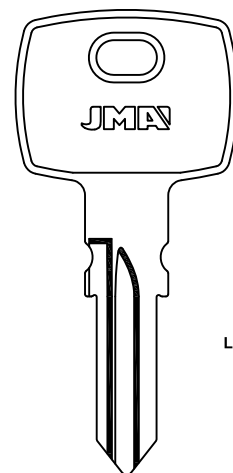

**TRP-1D**

LAT.

ZADI



**PARA-FOR:**

TRW-SIPEA (I)

UNION (GB)

| TRW-SIPEA |                | UNION |                 |
|-----------|----------------|-------|-----------------|
|           | ALP.           |       | LAT.            |
|           | <b>FI-16C1</b> |       | <b>FI-16.P1</b> |
|           |                |       | GIOBERT         |

| UNION   |  |
|---|--|
| <p>ASTON MARTIN<br/>JAGUAR<br/>LAND ROVER<br/>MG<br/>ROVER<br/>VOLVO</p> <p>FK<br/>01-99<br/>876-955</p> <p><b>IN-5</b></p> | <p>FP<br/>626-750</p> <p><b>IN-1</b></p> <p>FS<br/>01-99<br/>876-955</p> <p><b>IN-4</b></p> <p>FR<br/>751-875</p> <p><b>UN-4</b></p> |

| UNION   |  |                                       |   |
|---|--|---------------------------------------|---|
| <p>NRA<br/>FFE...1-100<br/>FJA...1-100<br/>FL...251-500<br/>NRA...51-90<br/>YFB...1-75<br/>FMD...1-75<br/>FG...1-30<br/>NF...1-30<br/>EJR...1-75</p> <p><b>UN-FFE</b></p> <p>MC...1-40<br/>MRA...251-290<br/>MRN...1-54<br/>MRN...201-250<br/>MRN...251-300</p> <p><b>UN-MRN</b></p> <p>FS...1-99<br/>FS...876-955</p> <p><b>UN-1FS</b></p> | <p>FP...<br/>626-750</p> <p><b>UN-FP</b></p> <p>FR...<br/>751-875</p> <p><b>UN-FR</b></p> <p>HX...100</p> <p><b>UN-2</b></p> <p>RM...<br/>911-952</p> <p><b>UN-44D</b></p> | <p>UN-3</p> <p>UN-FK</p> <p>UN-FS</p> | <p>KB682</p> <p><b>UN-46D</b></p> <p>UN-FK</p> <p>UN-FS</p> |
| BRITISH LEYLAND-FORD-HILLMAN-JAGUAR-LAND ROVER-MG-MORRIS-ROVER  |  | JAGUAR-VAUXHALL                       |   |

| UNION  |   |  |  |
|--|---|--|--|
| <p>FT-BC...301-360<br/>BC-FT...101-225<br/>LF...451-575<br/>CB...801-875</p> <p><b>UN-FT</b></p> <p>TF</p> <p>TF...1001-1140</p> <p><b>UN-TF</b></p> <p>BEDFORD-B.LEYLAND-FORD<br/>CEM</p> | <p>NC...<br/>1-1000</p> <p><b>UN-NC</b></p> | <p>NH...<br/>2001-3000</p> <p><b>UN-NH</b></p> <p>MG-ROVER-TRIUMPH<br/>CEM</p> | <p>NH...<br/>2001-3000</p> <p><b>UN-NH.P</b></p> <p>MG-ROVER-TRIUMPH<br/>CEM</p> |



## VACHETTE

PARA-FOR:

VACHETTE (F)

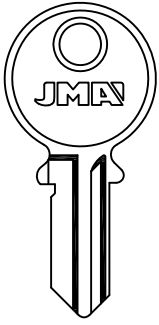

....1 AL 9 AL 0  
E...9001-9100  
....R9001-9100



VA-3I



VA-3

ISEO-KLIT

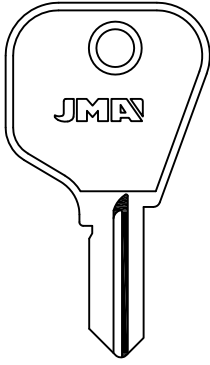

E...  
001-649



VA-6

CITROEN-PEUGEOT-TALBOT SIMCA

SIMPLEX

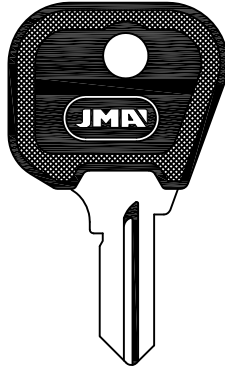

E...  
001-649



VA-6.P

CITROEN-PEUGEOT-TALBOT SIMCA

SIMPLEX

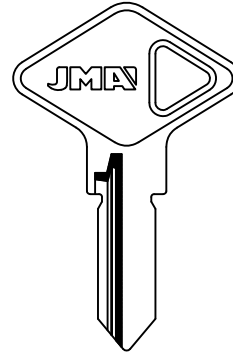

1R...000-999  
2R...1000-1837  
3R...000-665



VA-7

RENAULT-TALBOT SIMCA

## VACHETTE

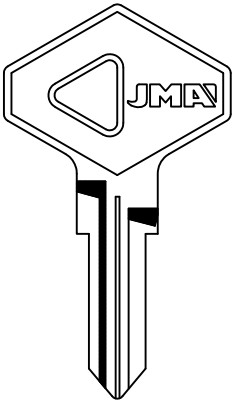

A/Z...  
...A/Z  
...A/Z 1/9  
2700-4816



VA-10

A.MOTORS-CHRYSLER-RENAULT

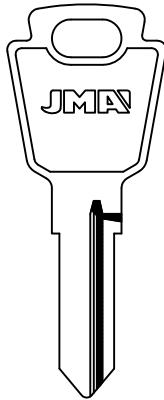

A...000-999  
B...000-999  
F...000-116



VA-16

TALBOT SIMCA

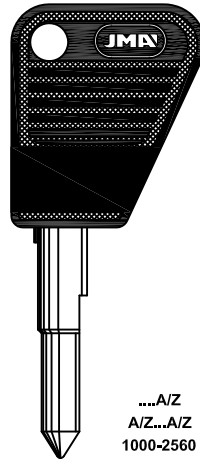

LAT.

...A/Z  
A/Z...A/Z  
1000-2560  
.E...A/Z 0 AL 4



VA-17.P

RENAULT  
NEIMAN

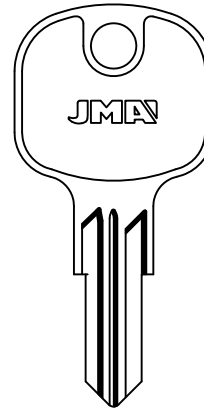

...E  
001-649



VA-18

PEUGEOT

## VACHETTE

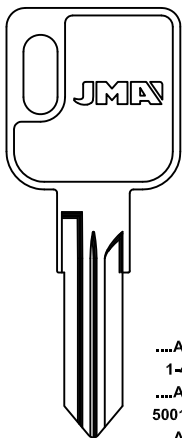

....A/Z 0/9  
1-4092  
....A/Z 0/9  
5001-9092  
....A/Z 0/9  
1-4092  
...A/Z 0/9  
5001-9092



VA-34

RENAULT

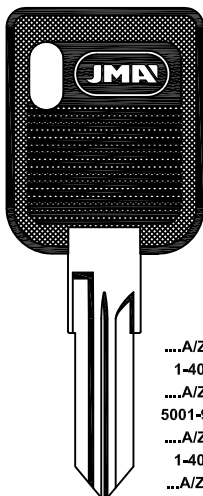

....A/Z 0/9  
1-4092  
....A/Z 0/9  
5001-9092  
....A/Z 0/9  
1-4092  
...A/Z 0/9  
5001-9092



VA-34.P

RENAULT

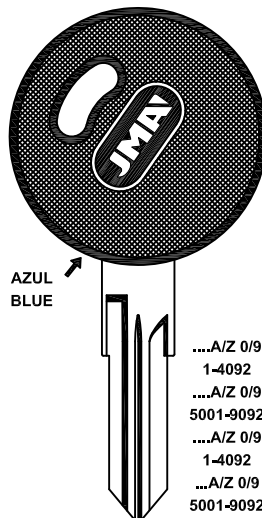

AZUL  
BLUE

....A/Z 0/9  
1-4092  
....A/Z 0/9  
5001-9092  
....A/Z 0/9  
1-4092  
...A/Z 0/9  
5001-9092



VA-34.P1

RENAULT



....A/Z 0/9  
1-4092  
....A/Z 0/9  
5001-9092  
....A/Z 0/9  
1-4092  
...A/Z 0/9  
5001-9092

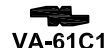

VA-61C1

**JMA**<sup>®</sup>

Copyright by Alejandro Altuna S.A. 2014



ATENCIÓN: Concerniente a las marcas y denominaciones comerciales ver nota en índice.  
ATTENTION: Concerning the marks and commercial denominations see note in index.  
ATTENTION: Concernant les marques et dénominations commerciales voir la note dans l'index.  
ACHTUNG: Beziehen auf die marke und handelsname sehen sie die notiz im index.











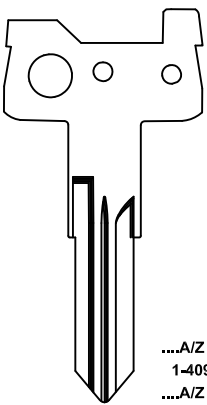



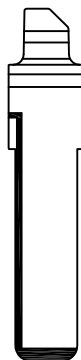



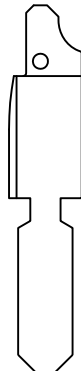

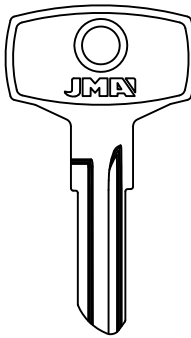

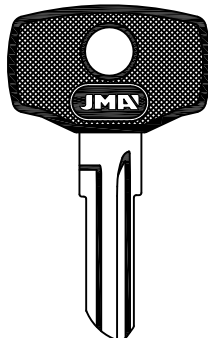

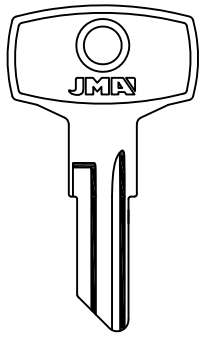

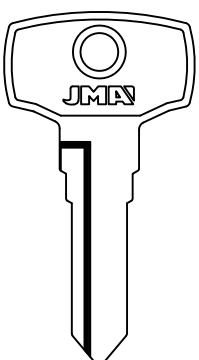

**PARA-FOR:**

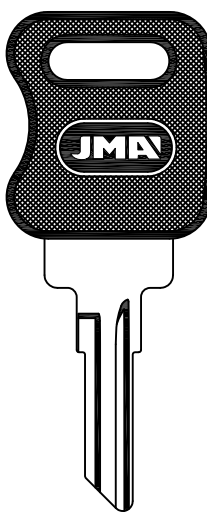
VACHETTE (F)

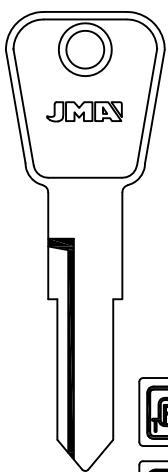
VALEO (F)

VOLGA (RUS)

WASO (D)

| VACHETTE  | VALEO   |  |  |
|---|---|--|--|
|  <p>....A/Z 0/9<br/>1-4092<br/>....A/Z 0/9<br/>5001-9092<br/>....A/Z 0/9<br/>1-4092<br/>...A/Z 0/9<br/>5001-9092</p>  <p><b>VA-61C2</b></p> |  <p>ALP.</p>  <p><b>HU-HAAC3</b></p>          |  <p>ALP.</p>  <p><b>HU-HAAC4</b></p>   |  <p>ALP.</p>  <p><b>PEU-1C1</b></p>  |
| VALEO   | VOLGA   |  |  |
|  <p>ALP.</p>  <p><b>PEU-2C1</b></p>  |  <p><b>JMA</b></p>  <p><b>VOL-1</b></p>    |  <p><b>JMA</b></p>  <p><b>VOL-1.P</b></p>  |  <p><b>JMA</b></p>  <p><b>VOL-2</b></p>  <p><b>VOL-2D</b></p>  <p><b>VOL-3</b></p> <p>GAZ-ZAZ</p> |
| VOLGA   |   | WASO   |  |
|  <p><b>JMA</b></p>  <p><b>VOL-4</b></p>   |  <p><b>JMA</b></p>  <p><b>VOL-5.P</b></p> |  <p><b>JMA</b></p>   <p>W...<br/>600-842</p>  <p><b>WAS-1</b></p> <p>JAGUAR-ROVER-SAAB-VOLVO</p> |  <p><b>JMA</b></p> <p>FR...4001-6000<br/>FZ...1-1232</p>  <p><b>WAS-2.P</b></p> <p>JAGUAR-MAZDA-SUBARU-TRIUMPH<br/>ARMAN-DOM</p>   |



## WASO

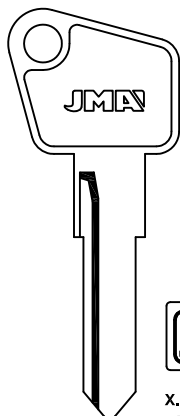

X...1-4088



**WAS-3**

D...1-4088

X...1-4088



**WAS-4**

DAF

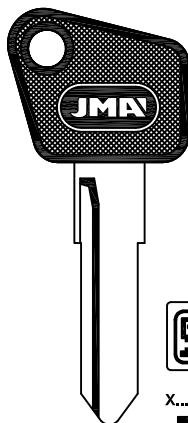

X...1-4088



**WAS-3.P**

D...1-4088

X...1-4088



**WAS-4.P**

DAF

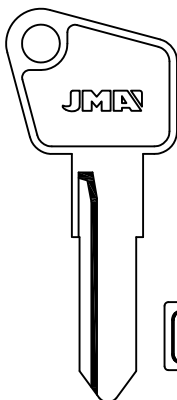

W...600-842



**WAS-5**

M...100-174



**WAS-6**

LOTUS-BEDFORD-DAF



W...600-842



**WAS-5.P**

M...100-174



**WAS-6.P**

LOTUS-BEDFORD-DAF

## PARA-FOR:

WASO (D)

WEST LOCK (USA)

WITTE (D)

YALE (D-GB-USA)

## WASO

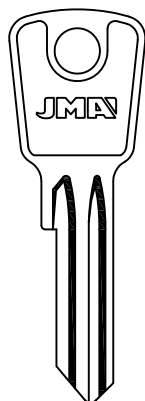

A.....

0 AL 5



**WAS-7**

TOK

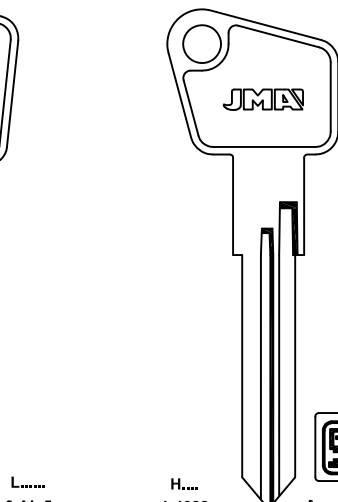

L.....

0 AL 5



**WAS-7D**

UNIPART

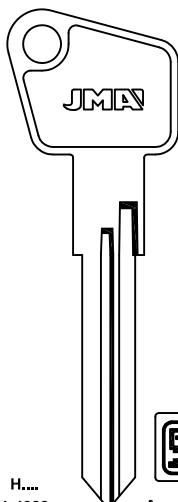

H....

1-4088



**WAS-8**

A....



**WAS-8D**

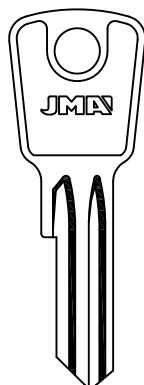

**WAS-9**

TOK WINKHAUS

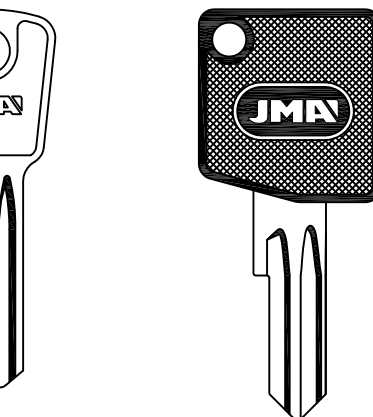

B.....

L.....

0 AL 5



**WAS-9D**



**WAS-10.P**

TRELOCK



**WAS-10D.P**

## WEST LOCK

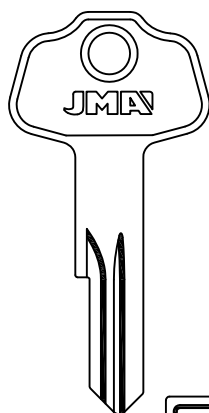

V....

1 AL 6



**WST-1D**

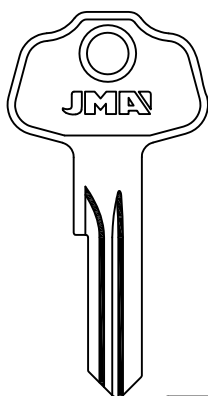

V....

1 AL 6



**WST-2D**

## WITTE

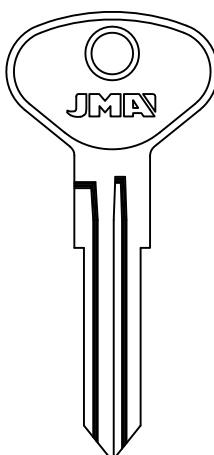

8001-8100



**WIT-1**

## YALE

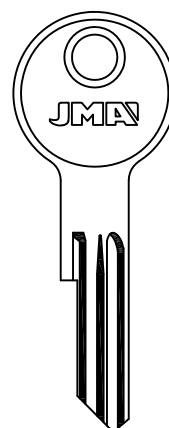

RRL



**YA-18D**

ROLLS ROYCE



**PARA-FOR:**  
 YALE (D-GB-USA)  
 YAMAHA (J)

**YALE**

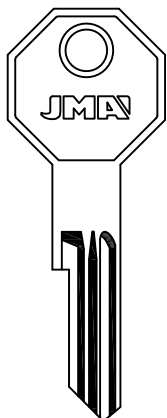

RRM  
**YA-19D**  
 ROLLS ROYCE

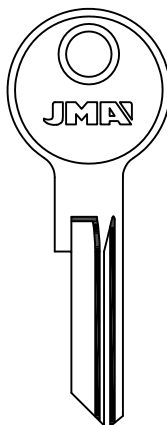

NRRL  
**YA-20I**  
 ROLLS ROYCE

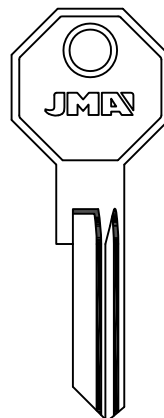

NRRM  
**YA-21I**  
 ROLLS ROYCE

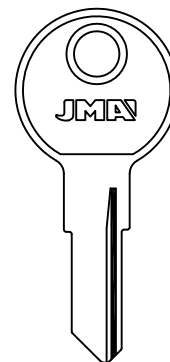

**YA-37** **YA-37D**  
 ADEMCO-BENDIX-CHICAGO  
 FORT-ILLINOIS

**YAMAHA**

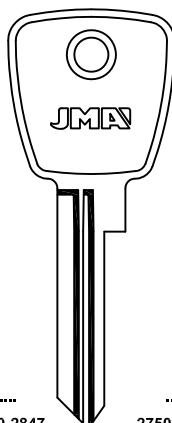

....  
 2840-2847  
**YAMA-1I**  
 2550-2557  
**YAMA-2I**  
 YAMAHA

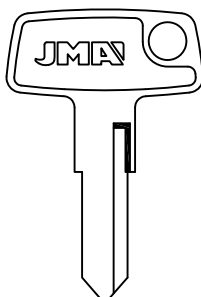

....  
 2750-2757  
**YAMA-1D**  
 2640-2647  
**YAMA-2D**  
 YAMAHA

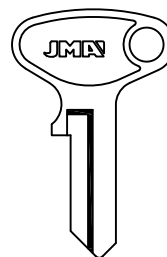

....  
 2611-2650  
**YAMA-3I**  
 YAMAHA

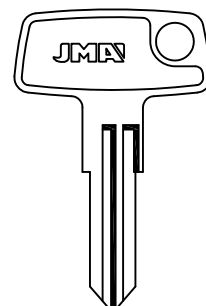

....  
 1711-1725  
**YAMA-3D**  
 YAMAHA

....  
**YAMA-4D**  
 YAMAHA

....  
 2651-2675  
**YAMA-5I**  
 YAMAHA

....  
 1751-1775  
**YAMA-5D**  
 YAMAHA

**YAMAHA**

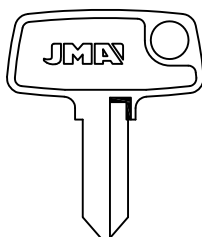

....  
 228-234  
**YAMA-6I**  
 YAMAHA

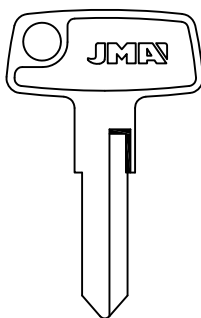

....  
 221-227  
**YAMA-6D**  
 YAMAHA

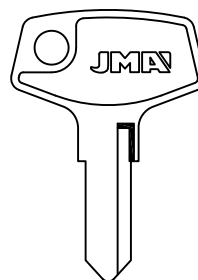

....  
 2676-2700  
**YAMA-7I**  
 YAMAHA

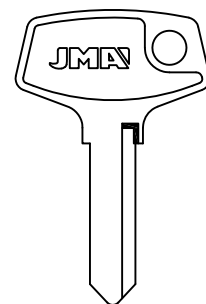

....  
 1776-1800  
**YAMA-7D**  
 YAMAHA

....  
 2109-2115  
**YAMA-8I**  
 YAMAHA

....  
 1209-1215  
**YAMA-8D**  
 YAMAHA

....  
 A201-A206  
**YAMA-9I**  
 YAMAHA

....  
 B201-B206  
**YAMA-9D**  
 YAMAHA



# YAMAHA

PARA-FOR:

YAMAHA (J)

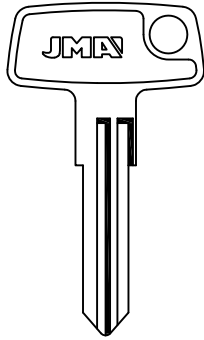

....  
2765-2771  
  
**YAMA-10I**  
....  
2758-2764  
  
**YAMA-11I**  
YAMAHA

....  
1855-1861  
  
**YAMA-10D**  
....  
1848-1854  
  
**YAMA-11D**  
YAMAHA

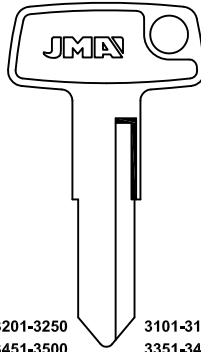

3201-3250  
3451-3500  
4401-4450  
  
**YAMA-12I**  
3251-3300  
3851-3900  
4451-4500  
  
**YAMA-13I**  
YAMAHA

3101-3150  
3351-3400  
4301-4350  
  
**YAMA-12D**  
3151-3200  
3751-3800  
4351-4400  
  
**YAMA-13D**  
YAMAHA

3801-3850  
4251-4300  
4851-4900  
  
**YAMA-14I**  
3401-3450  
4051-4100  
4651-4700  
  
**YAMA-15I**  
3651-3700  
4201-4250  
4801-4850  
  
**YAMA-16I**  
3701-3750  
4151-4200  
4751-4800  
  
**YAMA-14D**  
3301-3350  
3951-4000  
4551-4600  
  
**YAMA-15D**  
3551-3600  
4101-4150  
4701-4750  
  
**YAMA-16D**  
3501-3550  
3901-3950  
4501-4550  
  
**YAMA-17D**  
YAMAHA

# YAMAHA

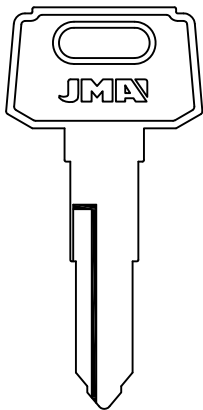

1 AL 4  
32010-79897

A.....  
32010-79897  
  
**YAMA-18I**

B.....  
32010-79897  
  
**YAMA-18D**

C.....  
32010-79897  
  
**YAMA-19I**

D.....  
32010-79897  
  
**YAMA-19D**

E.....  
32010-79897  
  
**YAMA-20I**

F.....  
32010-79897  
  
**YAMA-20D**

MALAGUTI-SUZUKI-YAMAHA

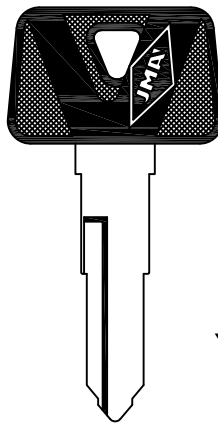

1 AL 4  
32010-79897

A.....  
32010-79897  
  
**YAMA-18I.P**

B.....  
32010-79897  
  
**YAMA-18D.P**

C.....  
32010-79897  
  
**YAMA-19I.P**

D.....  
32010-79897  
  
**YAMA-19D.P**

E.....  
32010-79897  
  
**YAMA-20I.P**

F.....  
32010-79897  
  
**YAMA-20D.P**

MALAGUTI-SUZUKI-YAMAHA

# YAMAHA

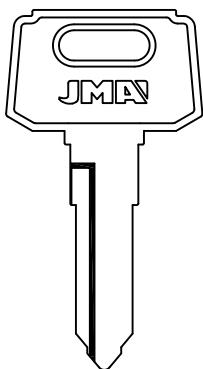

....  
7001-8000  
  
**YAMA-21I**  
HERCULES-YAMAHA

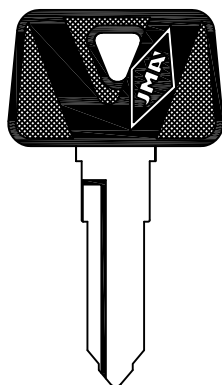

....  
7001-7999  
  
**YAMA-21I.P**  
HERCULES-YAMAHA

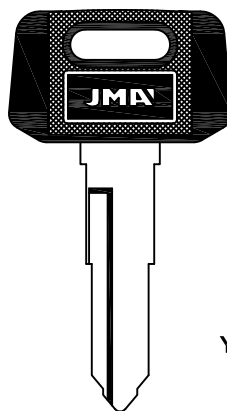

1 AL 4  
32010-79897

A.....  
32010-79897  
  
**YAMA-22I.P**

B.....  
32010-79897  
  
**YAMA-22D.P**

C.....  
32010-79897  
  
**YAMA-23I.P**

D.....  
32010-79897  
  
**YAMA-23D.P**

E.....  
32010-79897  
  
**YAMA-24I.P**  
YAMAHA

F.....  
32010-79897  
  
**YAMA-24D.P**



**PARA-FOR:**

YAMAHA (J)

YUGO (YU)

YMS (TW)

ZADI (I)

**YAMAHA**

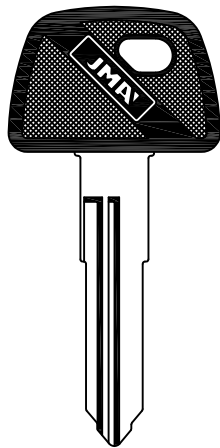

....  
6001-7000

**YAMA-25D.P**  
PUCH-VESPA-YAMAHA

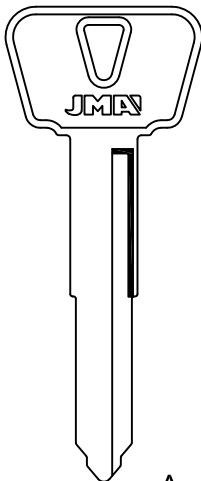

A....  
7000-8000

**YAMA-26**  
YAMAHA

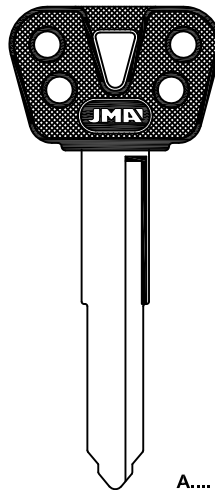

A....  
7000-8000

**YAMA-26P**  
YAMAHA

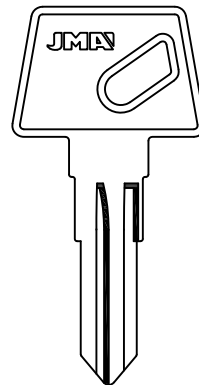

....3000

**YAMA-27**  
ITALJET-MALAGUTI-MBK-YAMAHA

....7000

**YAMA-27D**  
ITALJET-MALAGUTI-MBK-YAMAHA

**YAMAHA**

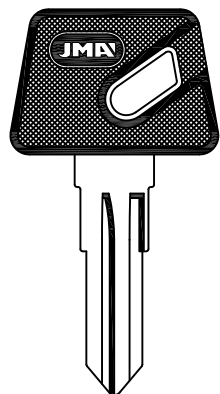

....3000 **YAMA-27P**  
....7000 **YAMA-27DP**

....4000 **YAMA-30.P**  
ITALJET-MALAGUTI-MBK-YAMAHA

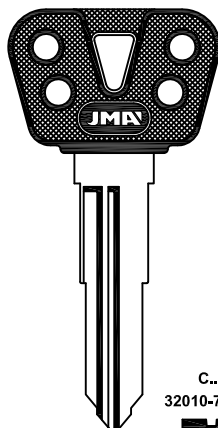

C....  
32010-79897  
 **YAMA-28.P**

E....  
32010-79897  
 **YAMA-29.P**  
YAMAHA

**YUGO**

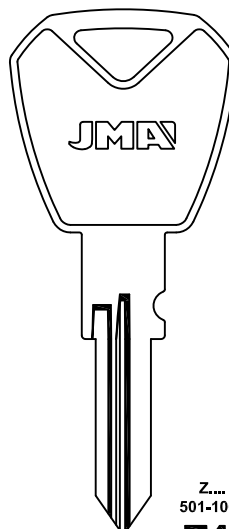

YUGO ZASTAVA

Z....  
501-1000  
 **YU-1D**

**YWS**

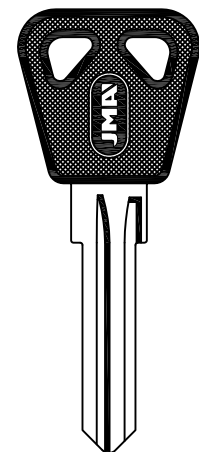

**YW-1.P**

ABUS

**ZADI**

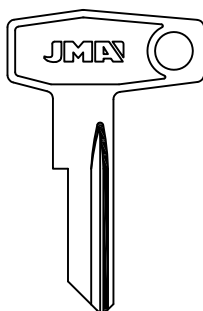

....1-1625  
....5001-6278  
E...1-710



**ZA-1**

BRETER

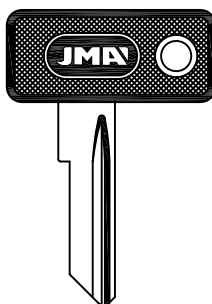

....1-1625  
....5001-6278  
E...1-710



**ZA-1.P**

BRETER

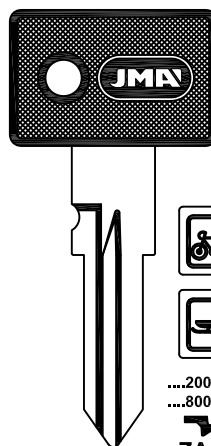

....2001-3554  
....8001-9554



**ZA-2.P**



**ZA-4D.P**

APRILIA-GILERA-PIAGGIO VESPA  
BASTA-VIRO

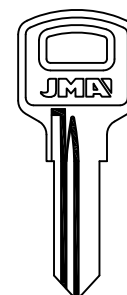

...1-390



**ZA-3D**





ZADI

PARA-FOR:

ZADI (I)

ZIL (RUS)

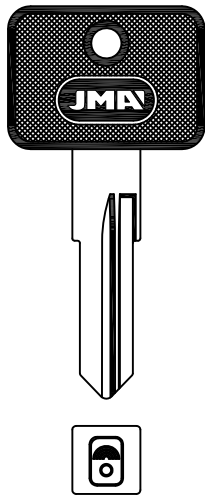

ZA-5.P ZA-5D.P

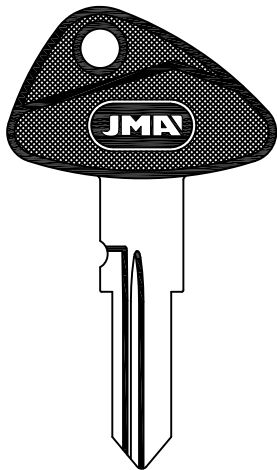

8001-9554  
ZA-6D.P  
BMW

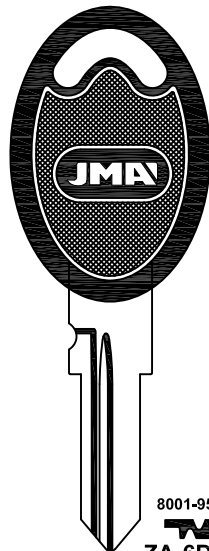

8001-9554  
ZA-6D.P1  
APRILIA-BETA

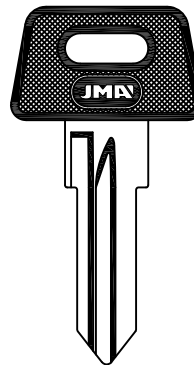

8001-9554  
ZA-7D.P  
GILERA-PIAGGIO

ZADI

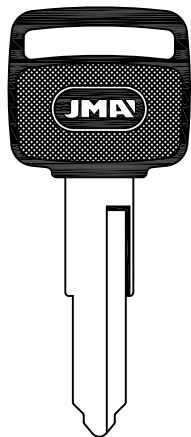

ZA-8.P

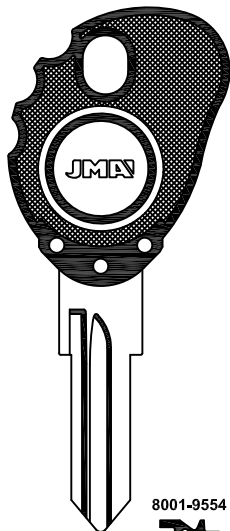

8001-9554  
ZA-9.P  
MALAGUTI-MBK

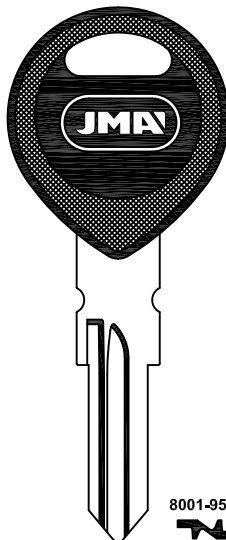

8001-9554  
ZA-9.P1  
PIAGGIO-MBK-YAMAHA

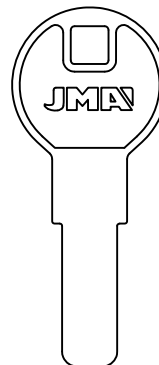

LAT.

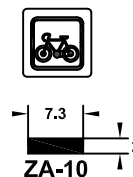

ZA-10

ZADI

ZIL

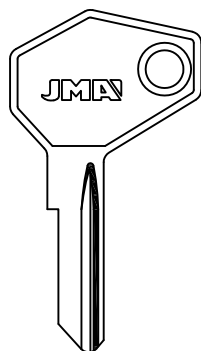

....1-1625  
....5001-6278  
E...1-710

ZA-12

BRETER

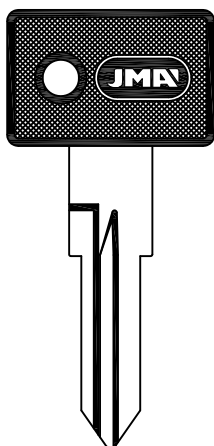

....5001-6475  
ZA-13.P

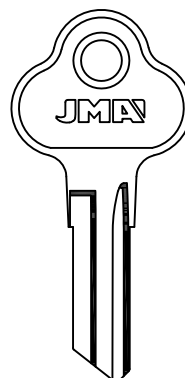

ZI-1



# **LLAVES DE CIERRE**

*IXTEKO GILTZAK*

*SNAP-LOCK KEYS*

*CLES DE BOUCHE D'EAU*

*DORNSCHLÜSSEL*



**THE KEY TO EXCELLENCE**  
GLOBALLY UNLOCKING MILLIONS OF DOORS DAILY

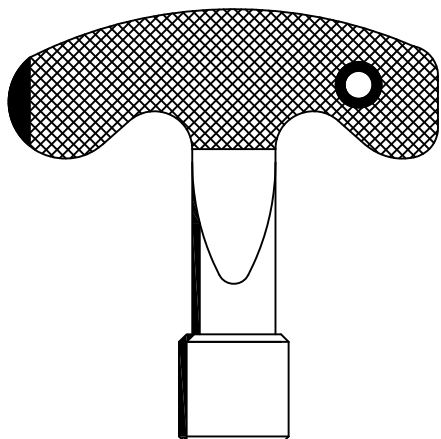

ZAM.

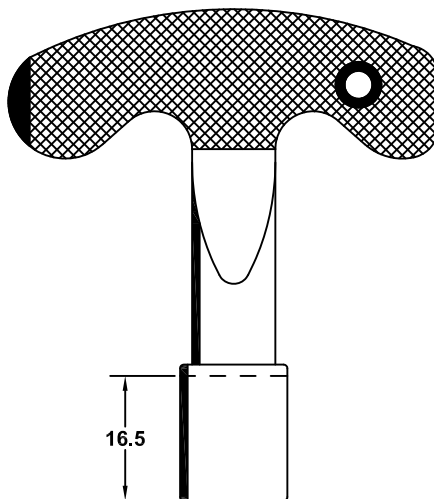

ZAM.



6  
500



7  
501



8  
502



10  
503



6  
504



8  
505



10  
506



8.5  
507



8  
508

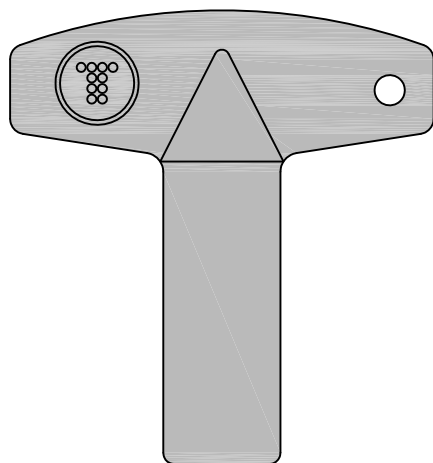

PLAS.

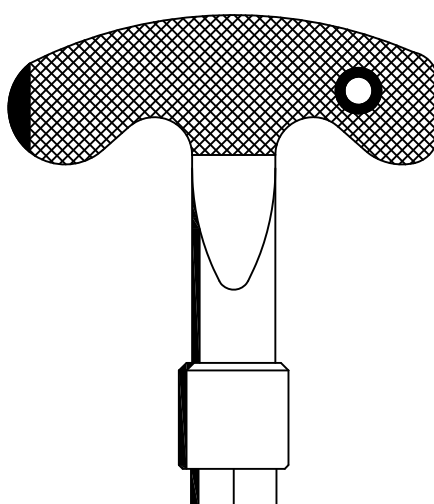

ZAM.

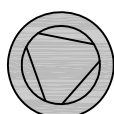

9.5  
509

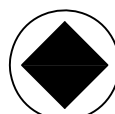

8  
510



PARA-FOR:

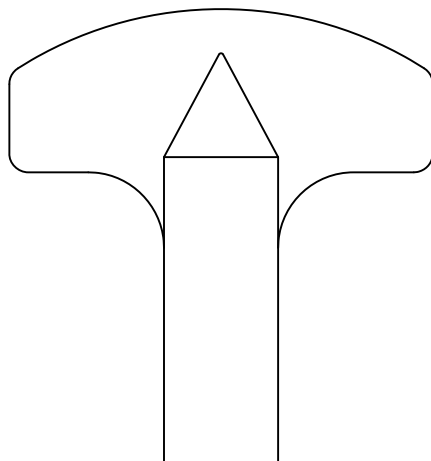

ALU.

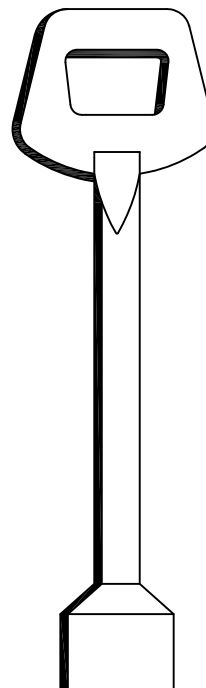

ZAM.



8.5  
511



10  
512

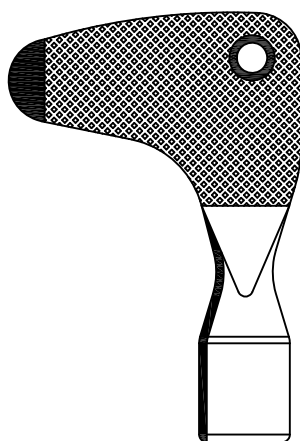

LAT.



8.5  
513  
ORONA



# **LLAVES EN CRUZ**

*GURUTZE-GILTZAK  
CRUCIFORM KEYS  
CLES CRUCIFORMES  
KREUTZSCHLÜSSEL*



**THE KEY TO EXCELLENCE**  
GLOBALLY UNLOCKING MILLIONS OF DOORS DAILY

**PARA-FOR:**







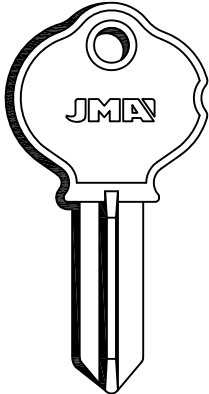
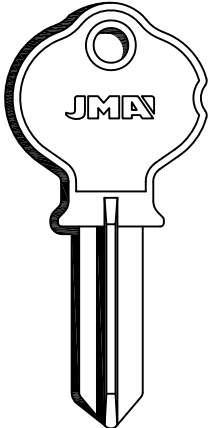
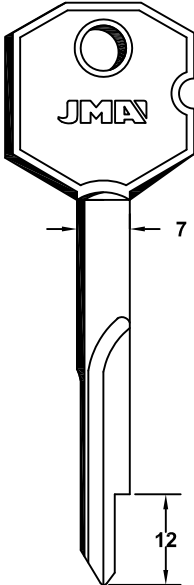
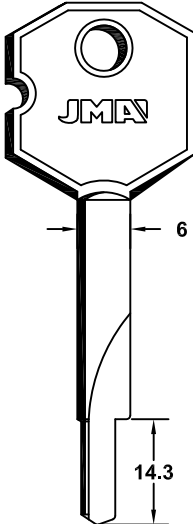

AGC (P)

ALA (I)

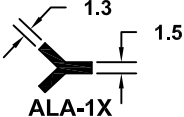
BLUMA (D)

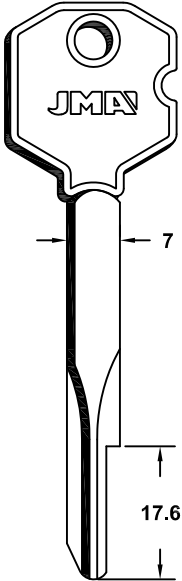
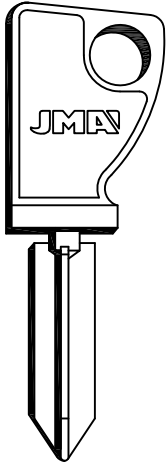
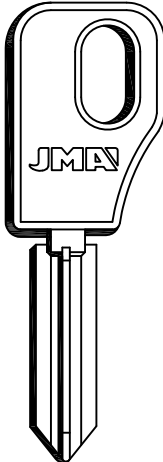
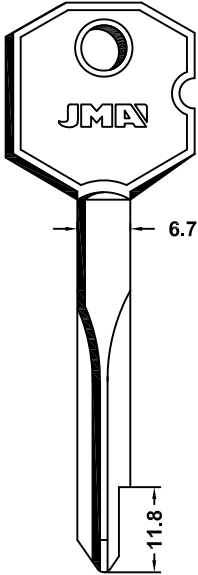
BRICARD (F)

BURG (D)

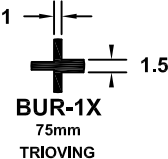
| AGC   |   | ALA  | BLUMA   |
|---|---|--|---|
|                    |                    |              |                                  |
| <br>AGD-1X<br>CCF3 | <br>AGD-2X<br>CCF3 | <br>ALA-1X | <br>BLU-1X                       |
| BLUMA   | BRICARD   |  | BURG  |
|                  |                  |           |                                |
| <br>BLU-2X       | <br>BRI-1X       | <br>BRI-2X  | <br>BRI-3X                     |
|   |   |  | <br>BUR-1X<br>75mm<br>TRIOVING |



## BURG

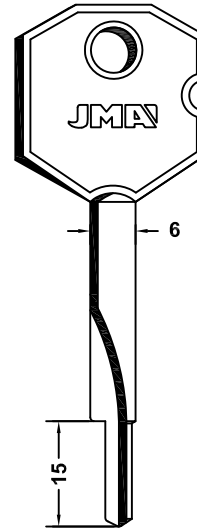
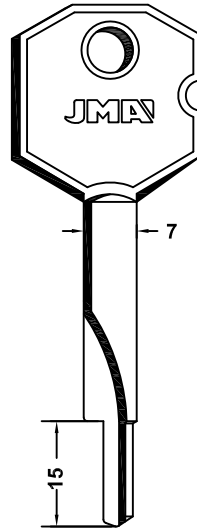
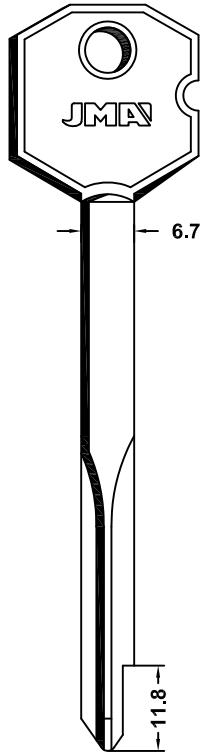
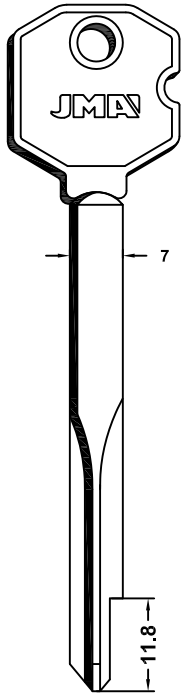

## PARA-FOR:

BURG (D)

CCF (P)

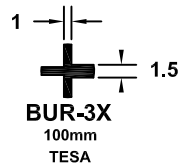
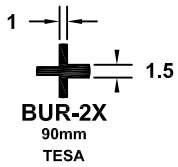



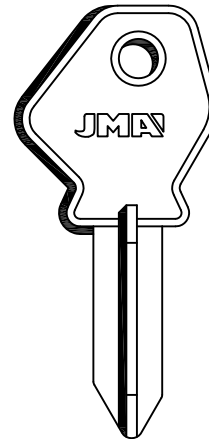
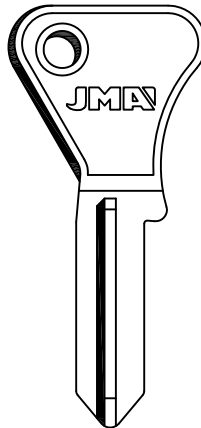
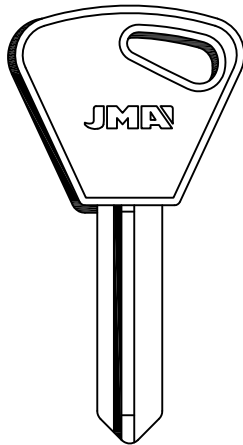
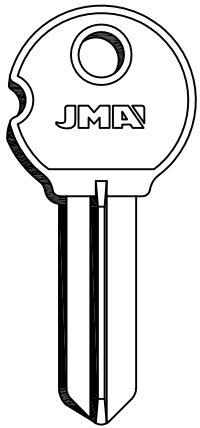

## CCF

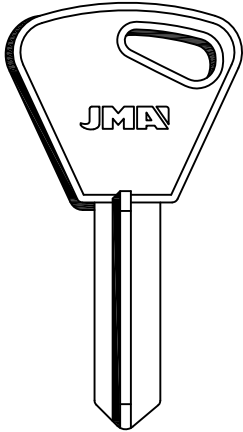
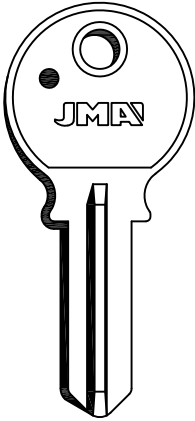
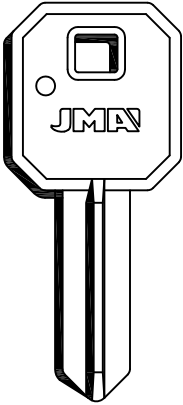
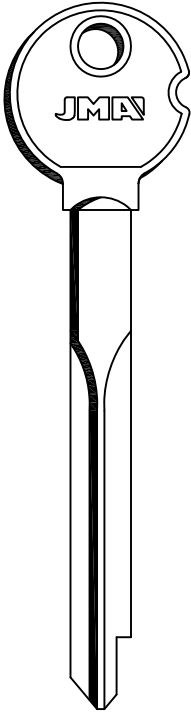

**PARA-FOR:**

- CCF (P)
- CIFIAL (P)
- CRC CAMBOA (P)
- DEBEAURAIN (F)
- DOOR LOCK
- FAYN (TR)
- FIAM (I)

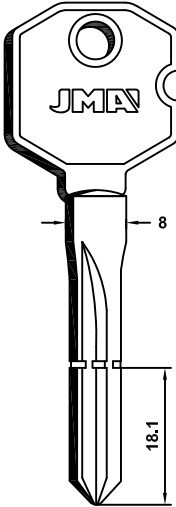
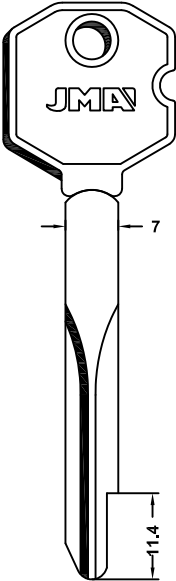
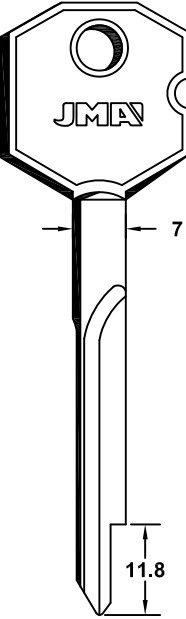
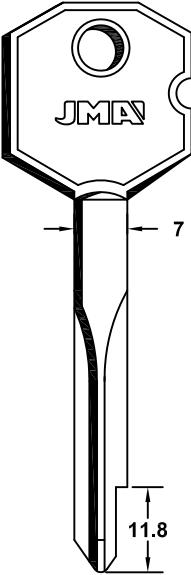
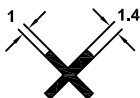
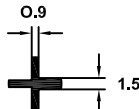
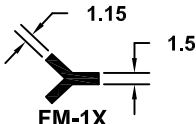
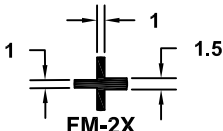
|  | CCF   | CIFIAL  | CRC CAMBOA   | DEBEAURAIN   |
|--|---|---|--|--|
|  |              |                    |              |             |
|  | <br>CCF-10X  | <br>CIF-1X<br>CCF4 | <br>CRC-1X  | <br>DEB-1X  |
|  | DOOR LOCK   | FAYN  | FIAM   |  |
|  |            |                  |            |           |
|  | <br>DOL-1X | <br>FAY-1X       | <br>FM-1X | <br>FM-2X |





**FRIPA**

**GERA**

**PARA-FOR:**

FRIPA (D)

GERA (D)

HELCO KFV (D)

ISEO (I)

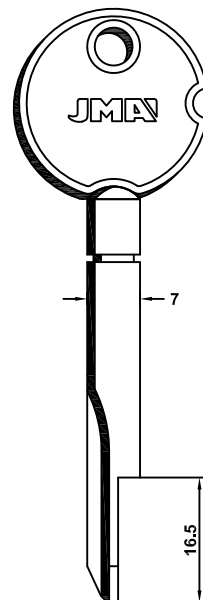
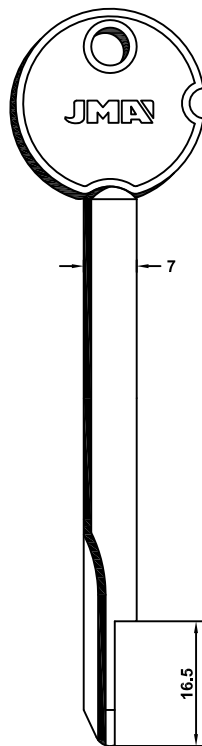
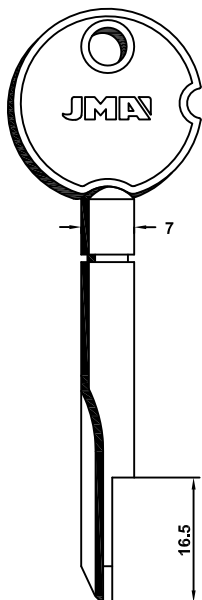
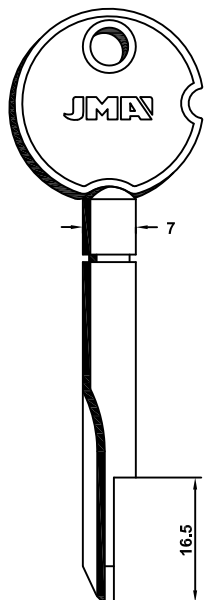

1.2



**FRI-1X**

GERA

1.1



**FRI-2X**

GERA

1.25



**GEA-1X**

1.1



**GEA-3X**

**HELCO KFV**

**ISEO**

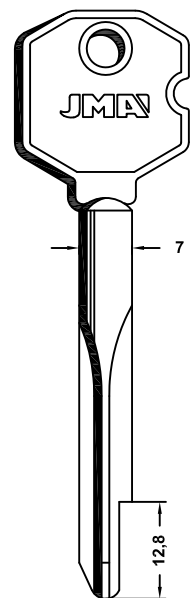
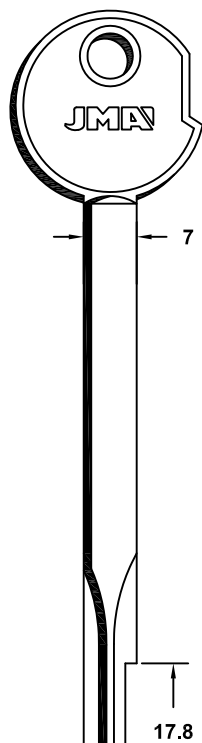
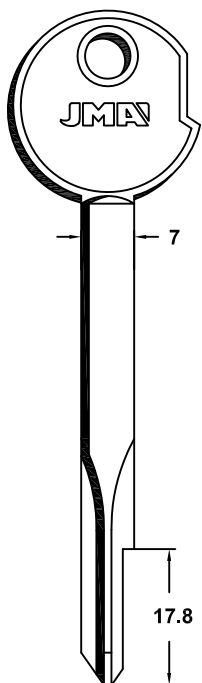
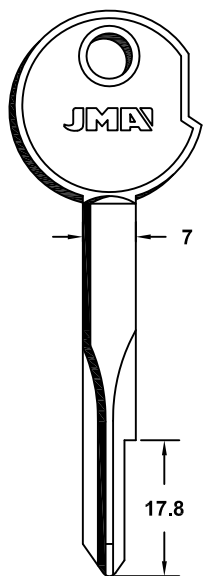

1.15



**KFV-1X**  
75mm

1.15



**KFV-2X**  
85mm

1.15



**KFV-3X**  
100mm

1



**IS-1X**

1,5



PARA-FOR:  
KRESTI (RUS)

KRESTI

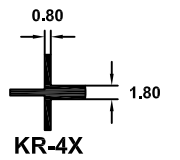
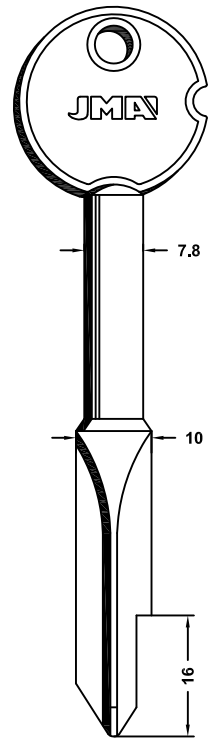
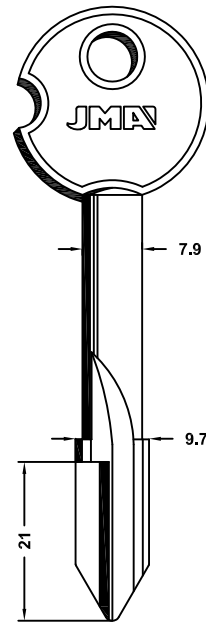
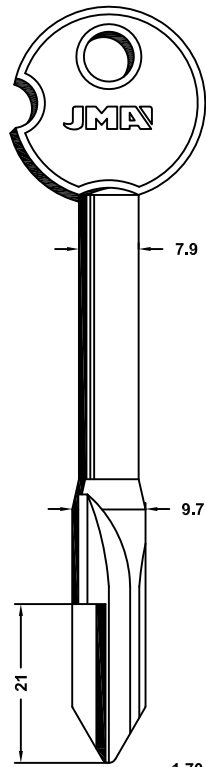
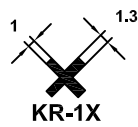
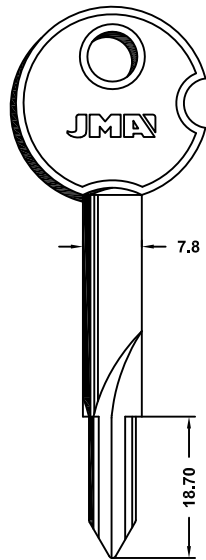

KRESTI

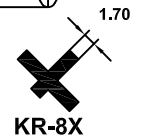
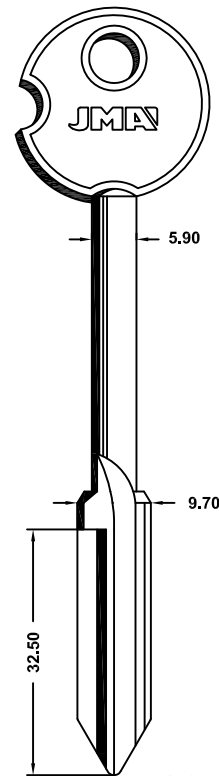
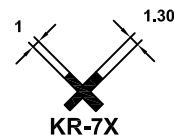
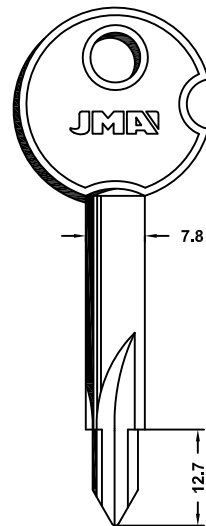
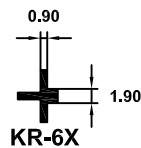
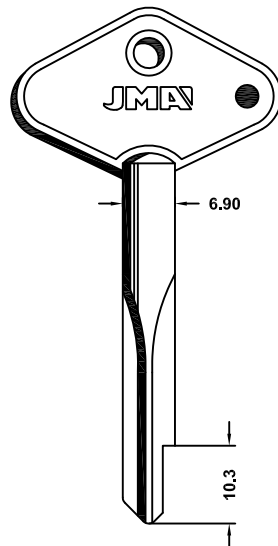
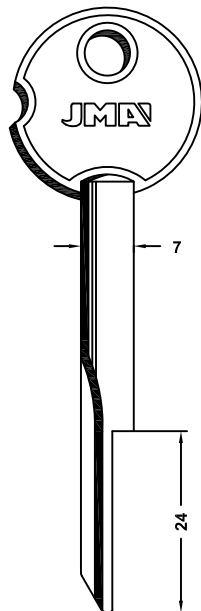

# KRESTI

PARA-FOR:  
KRESTI (RUS)

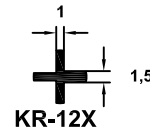
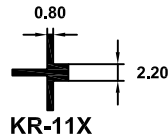
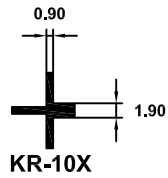
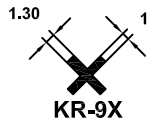
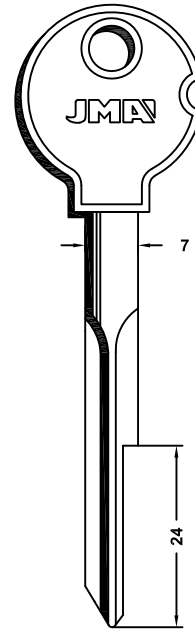
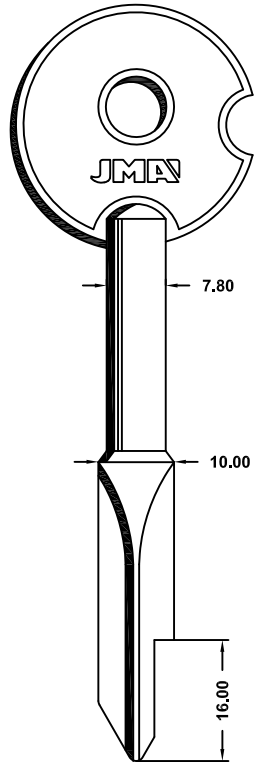
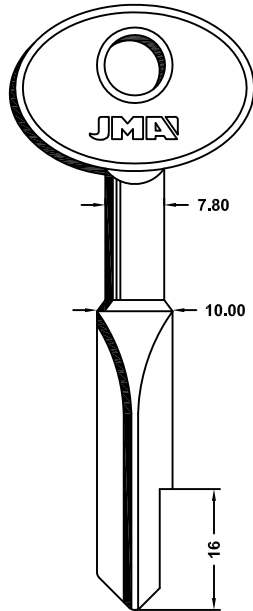
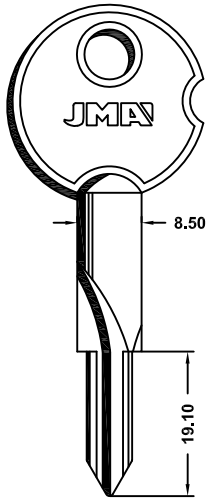

# KRESTI

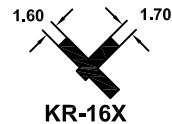
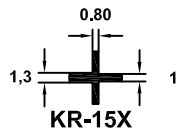
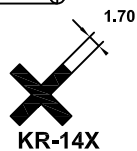
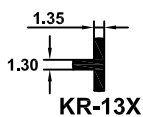
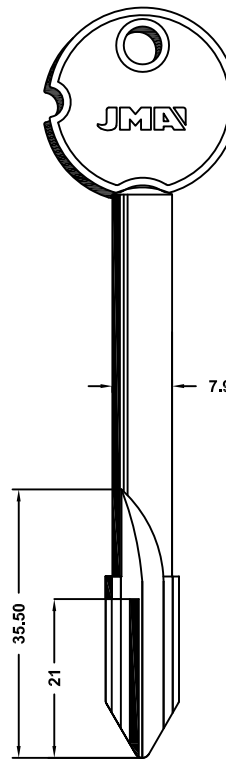
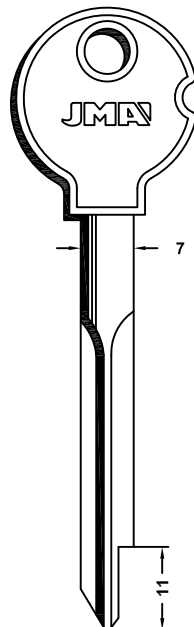
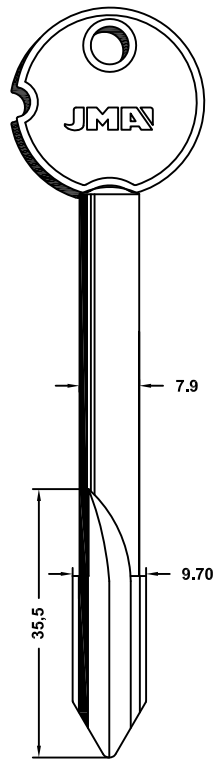
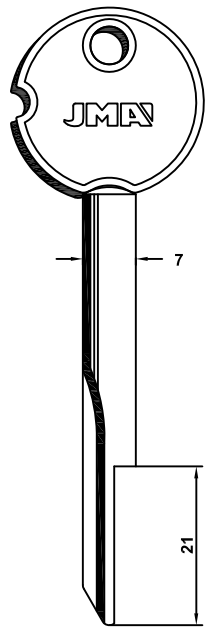

**PARA-FOR:**

KRESTI (RUS)

LOCK-IT (GB)

MAFOR (F)

MINI MOLA (P)

MOREAUX (F)

MSV (P)

NABOB (IL)

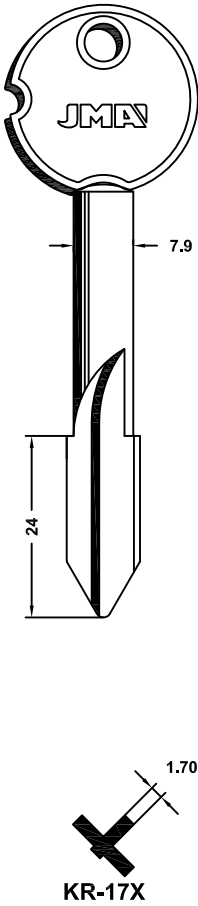
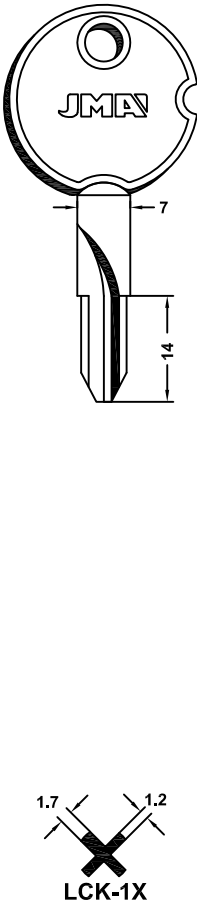
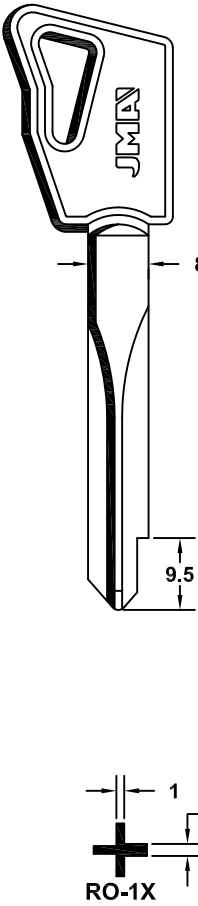
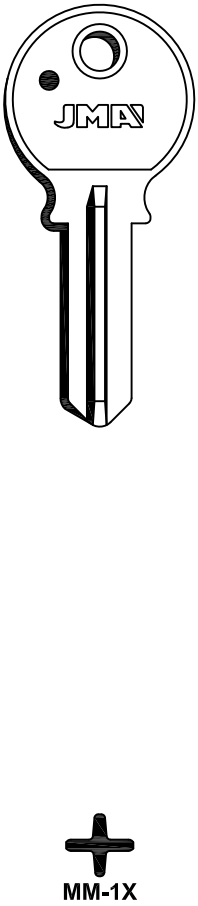
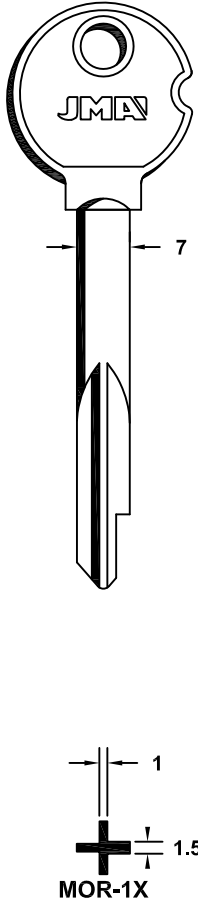
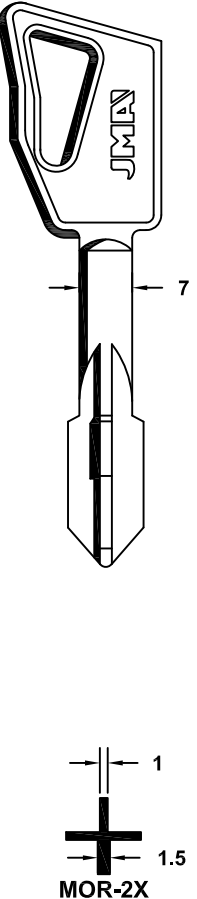
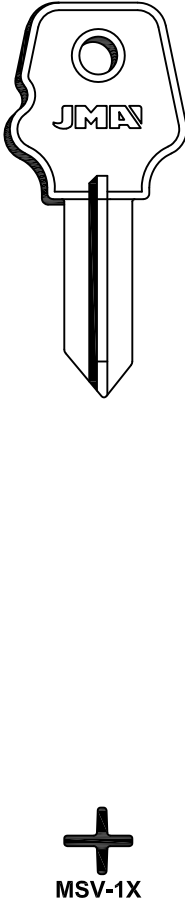
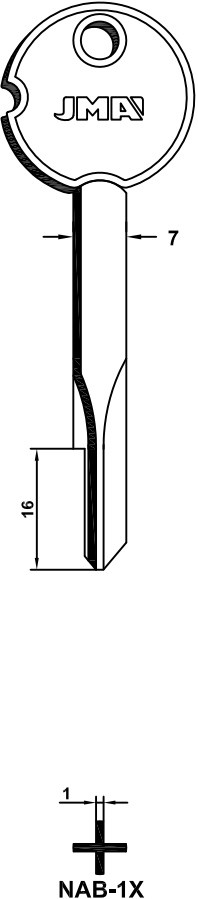
| KRESTI  | LOCK-IT   | MAFOR  | MINI MOLA  |
|---|---|--|--|
|  <p>KR-17X</p>  |  <p>LCK-1X</p>  |  <p>RO-1X<br/>RONIS-SOS</p> |  <p>MM-1X<br/>CCF7<br/>ANA</p> |
| MOREAUX   |   | MSV  | NABOB  |
|  <p>MOR-1X</p> |  <p>MOR-2X</p> |  <p>MSV-1X</p>             |  <p>NAB-1X</p>                |



**PARA-FOR:**

- NEMEF (D)
- PAPAIZ (BR)
- TUFF (HK)
- UNIVERSAL
- YALE BKS (I-D)

**NEMEF**

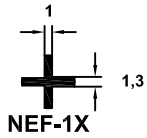
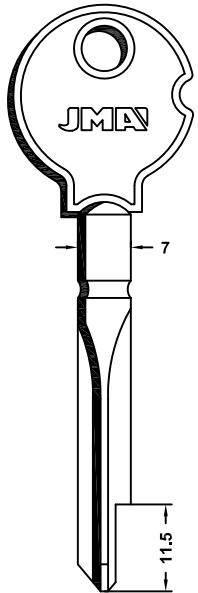

**PAPAIZ**

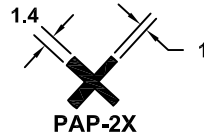
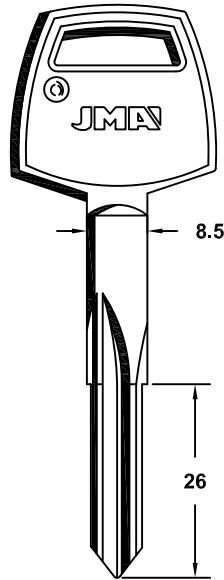
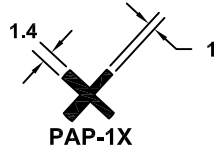
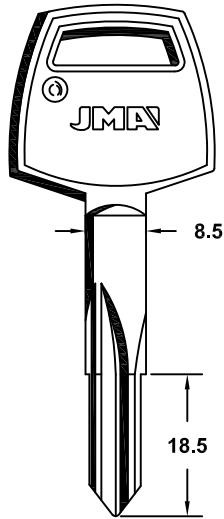

**TUFF**

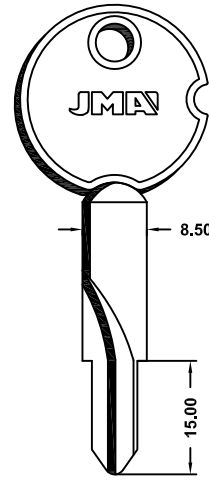

**TUFF**

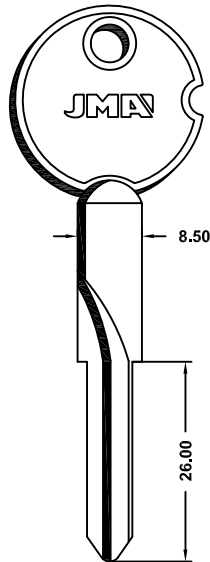
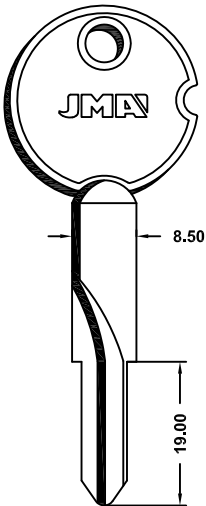

**UNIVERSAL**

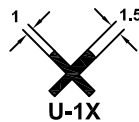
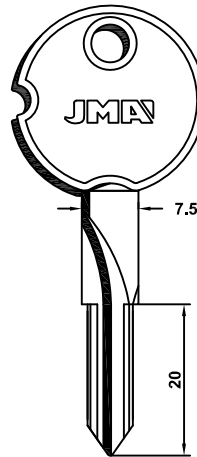

**YALE BKS**

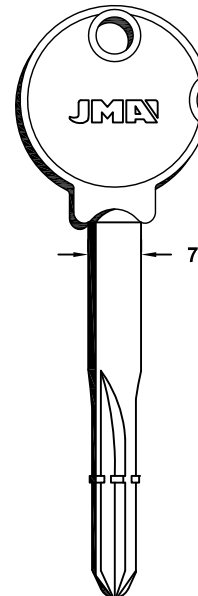

**PARA-FOR:**

YALE BKS (I-D)

ZEISS IKON (D)

**YALE BKS**

**YALE**

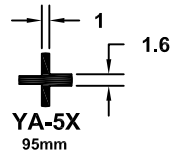
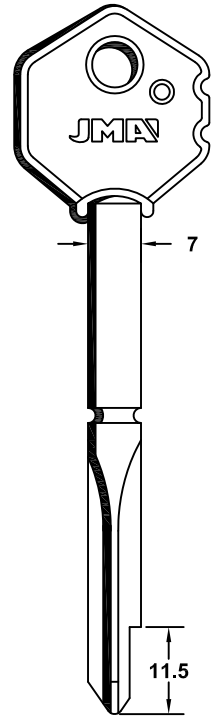
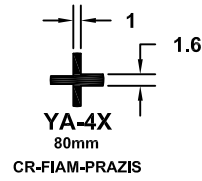
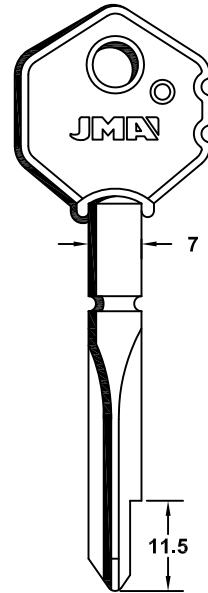
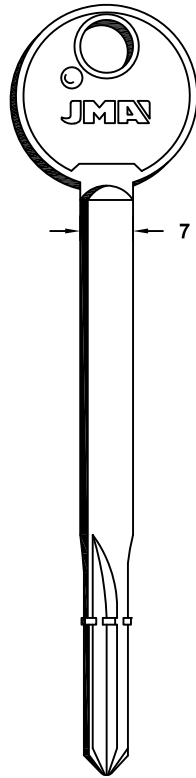
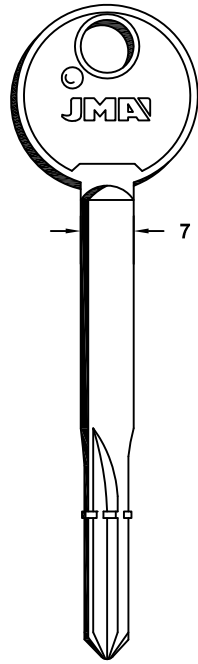

**YALE**

**ZEISS IKON**

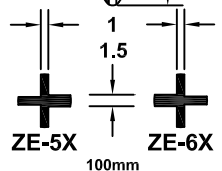
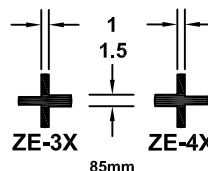
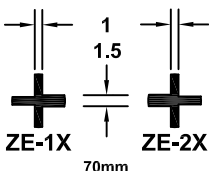
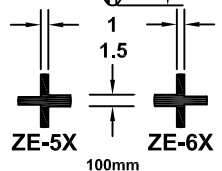
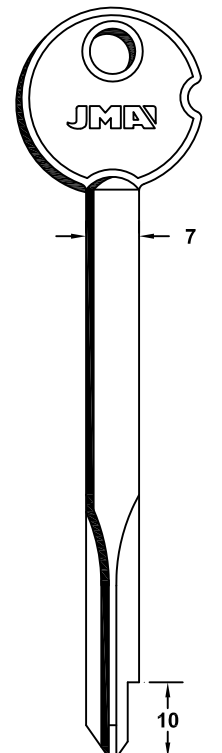
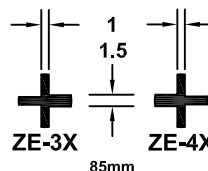
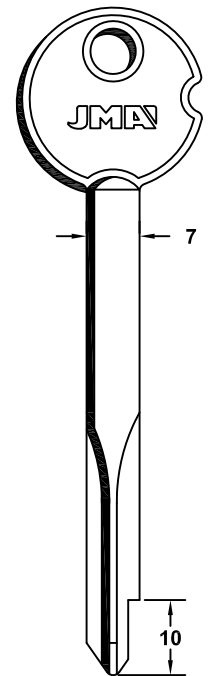
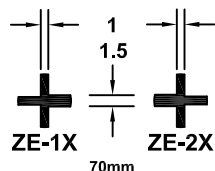
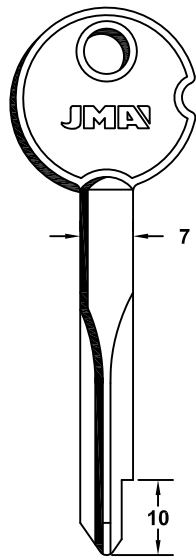
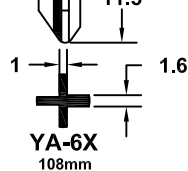
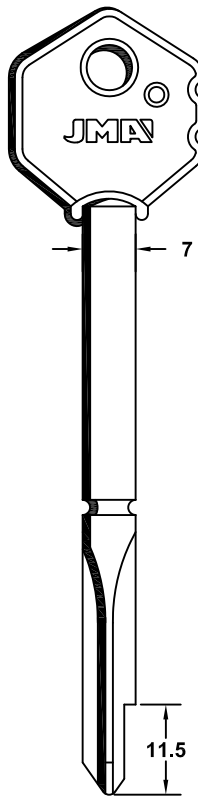

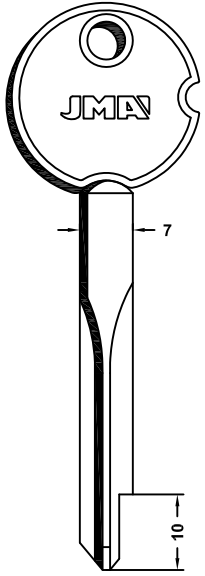

  
**ZE-7X**  
75mm

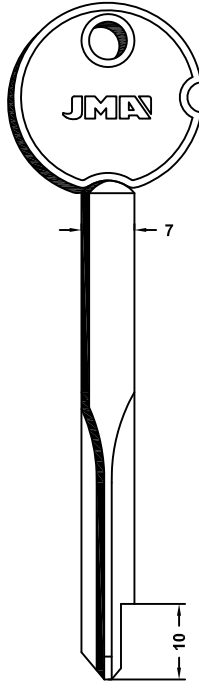

  
**ZE-8X**  
90mm

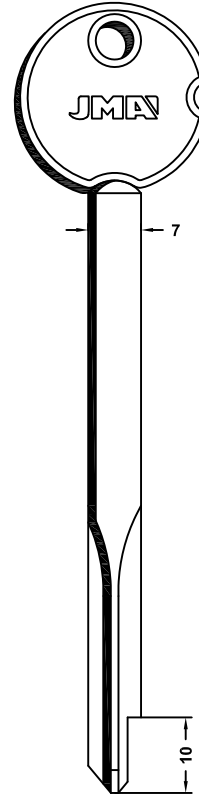

  
**ZE-9X**  
105mm



# **LLAVES DE GORJA ACERO DULCE**

*ALTZAIRU GOZOZKO GORJA-GILTZA  
MILD STEEL BIT KEYS  
CLES A GORGES EN ACIER DOUX  
CHUBBSCHLÜSSEL AUS WEICHSTAHL*

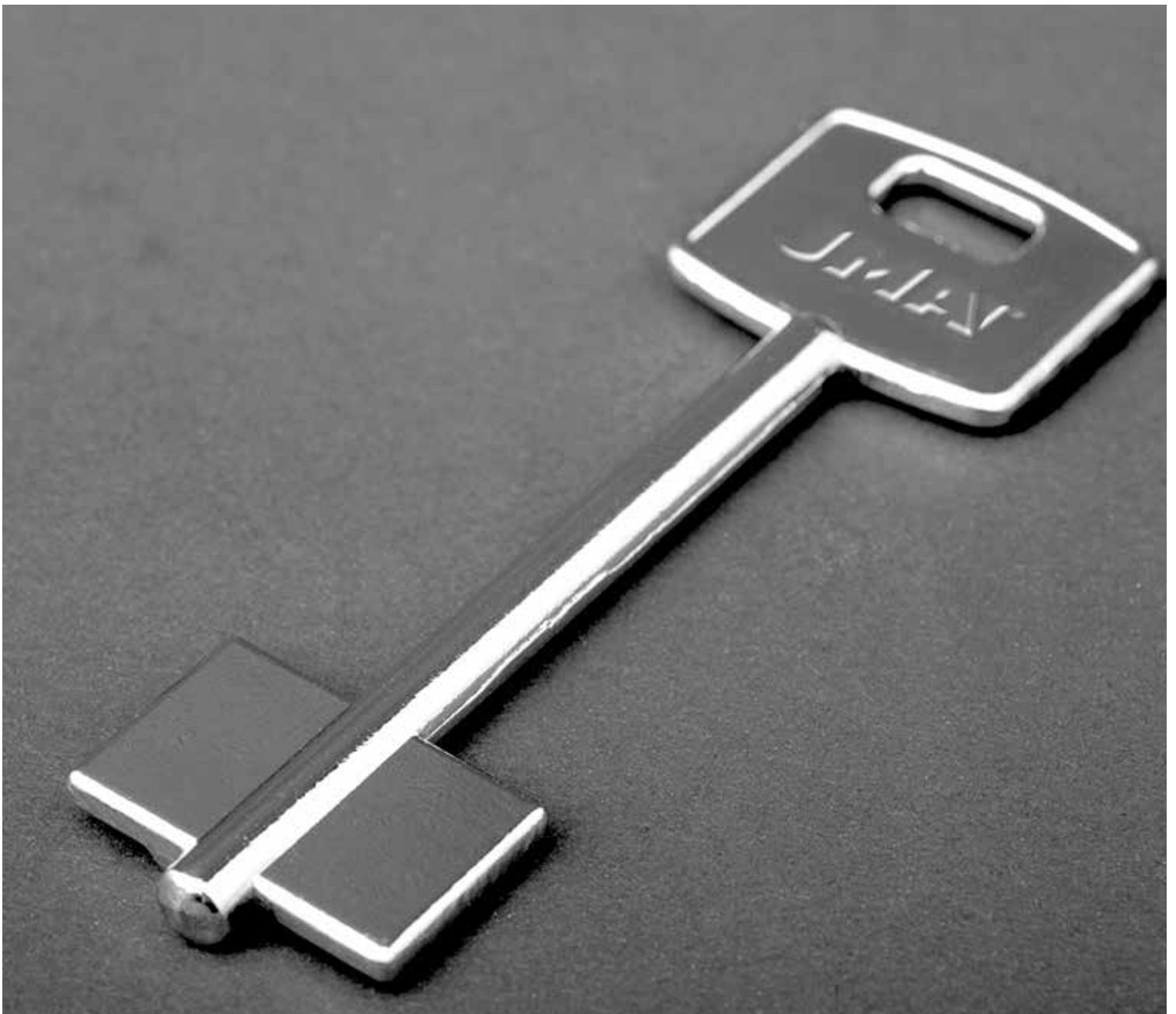

**THE KEY TO EXCELLENCE**  
GLOBALLY UNLOCKING MILLIONS OF DOORS DAILY



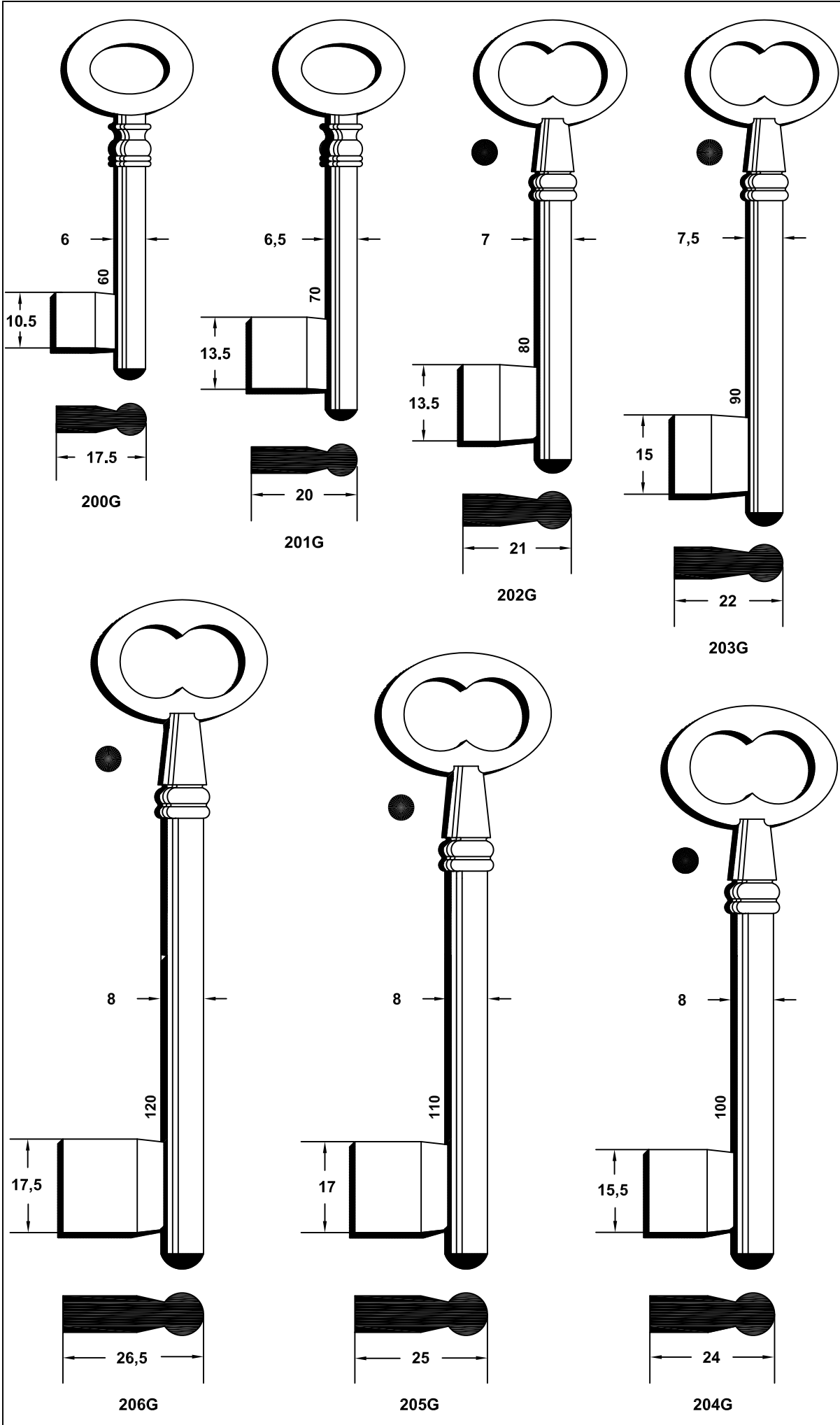

PARA-FOR:

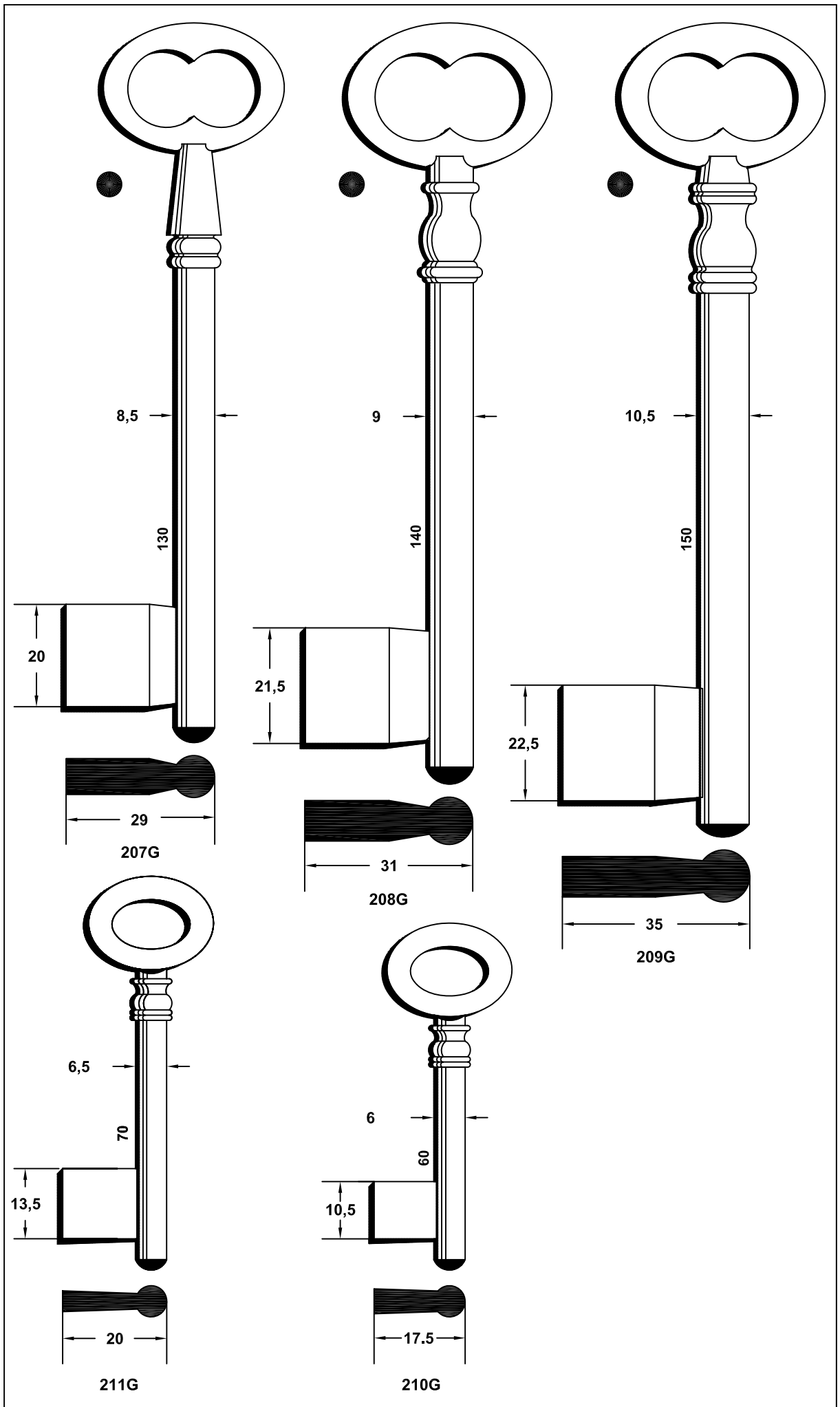

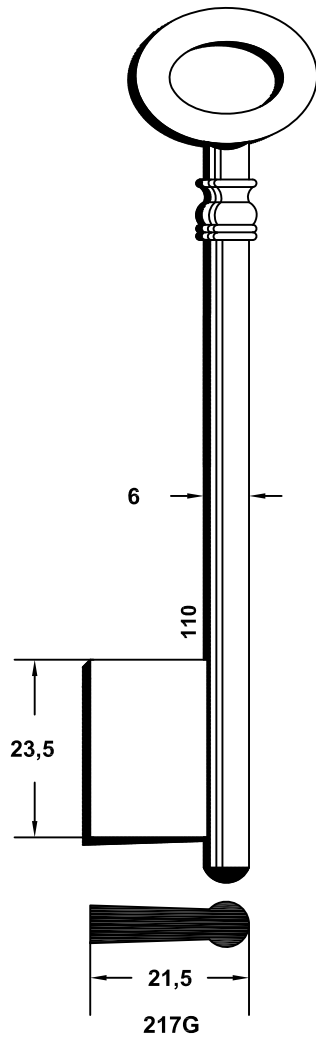
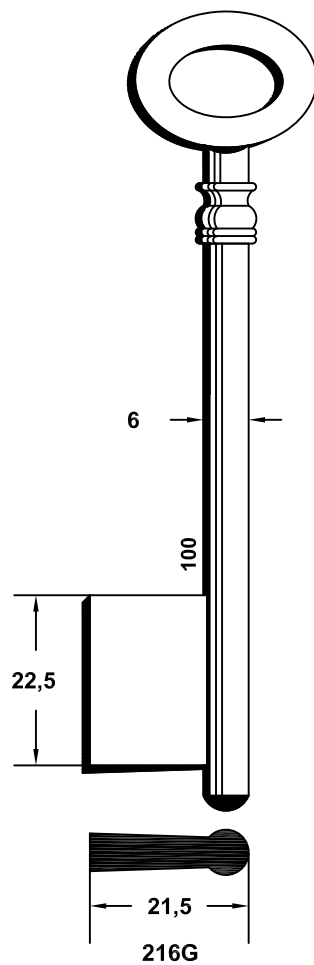
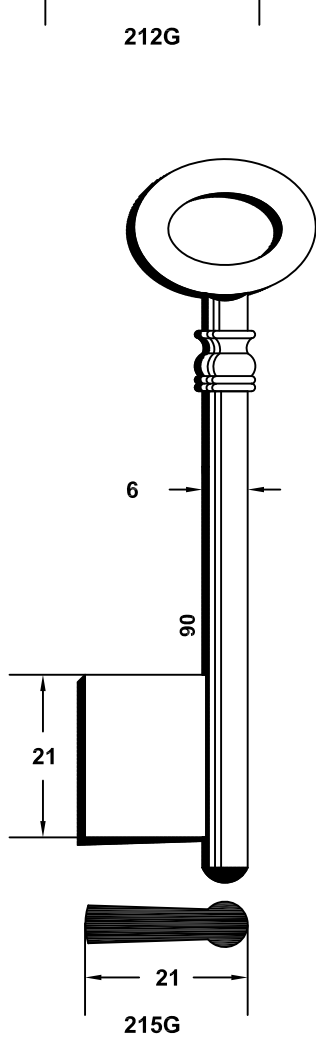
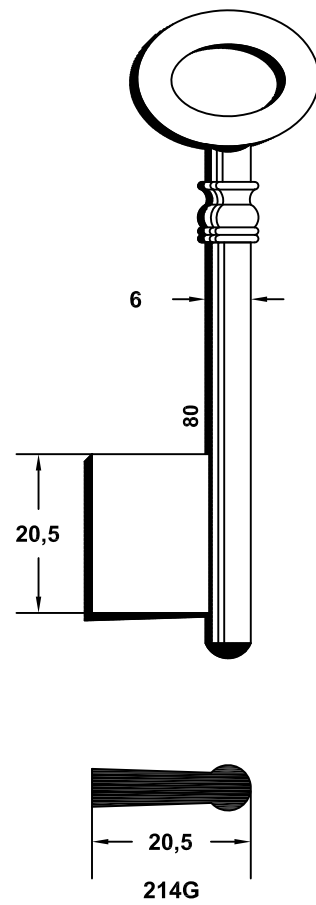
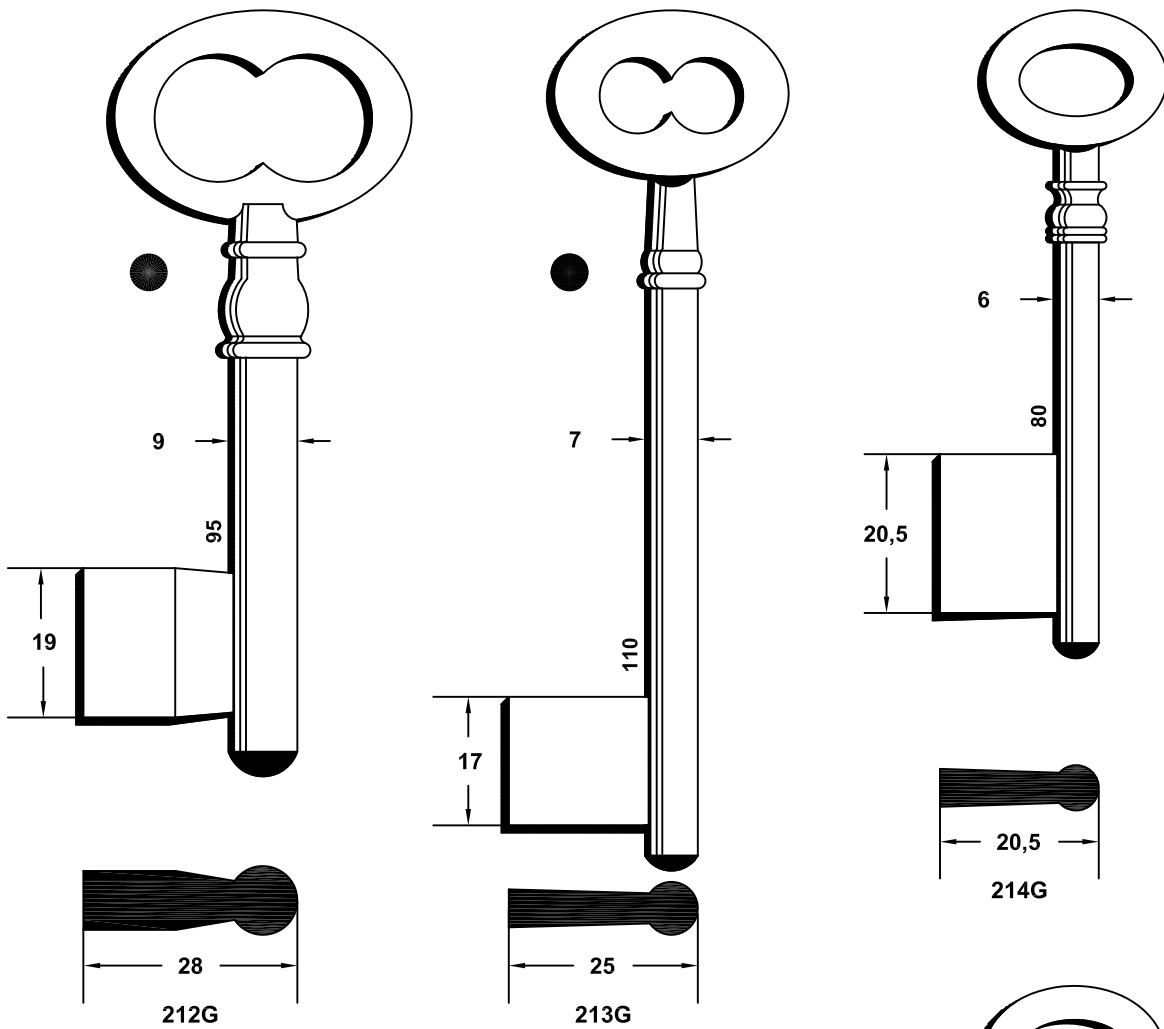

PARA-FOR:

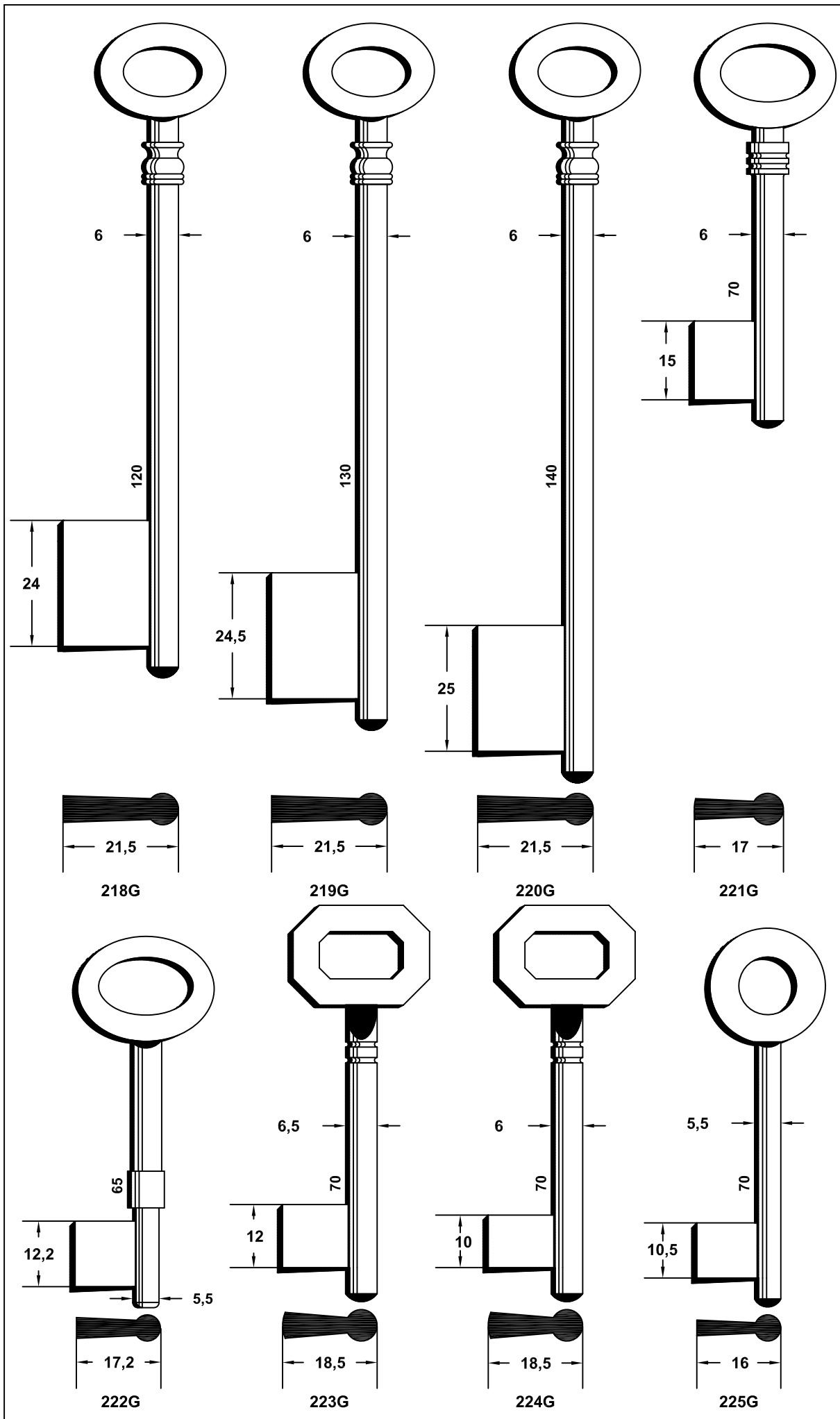

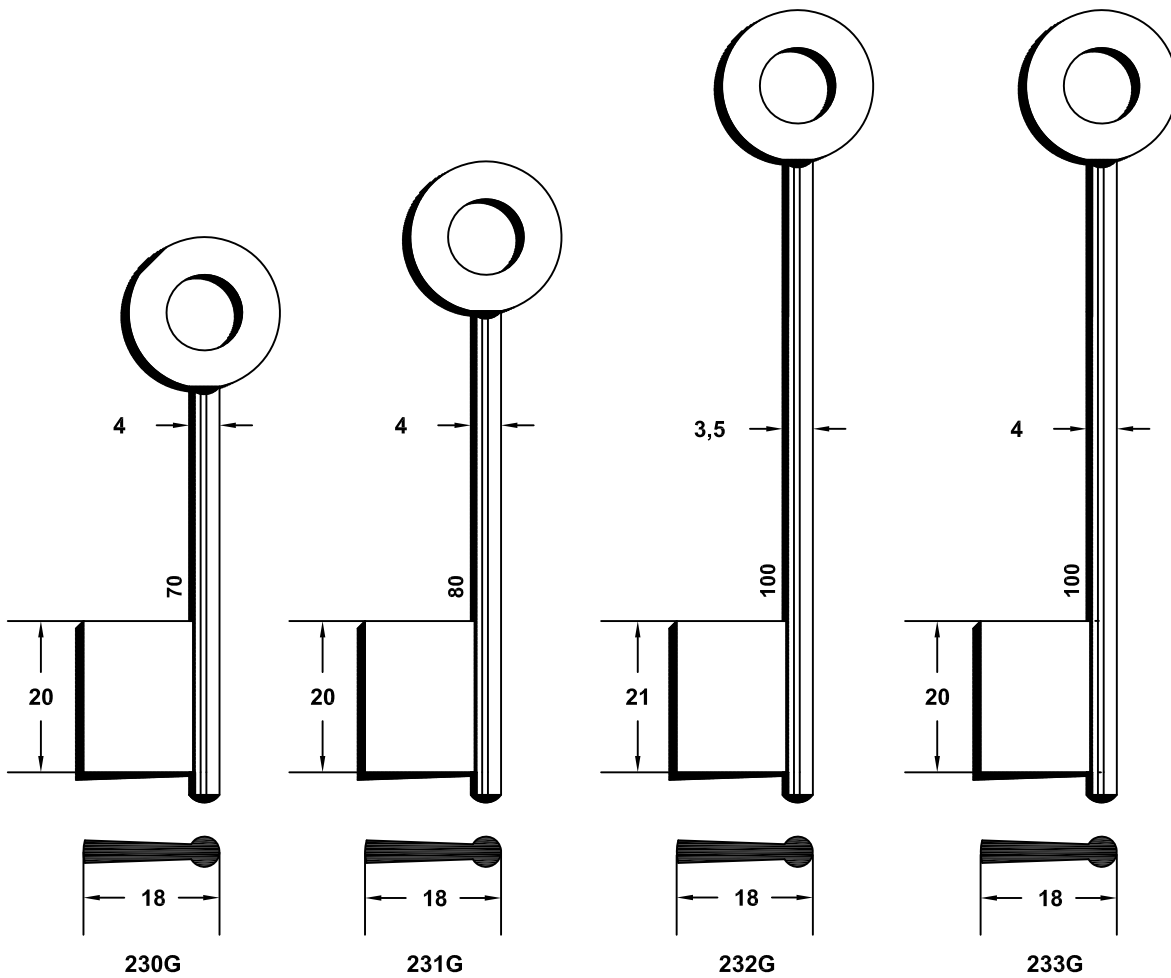
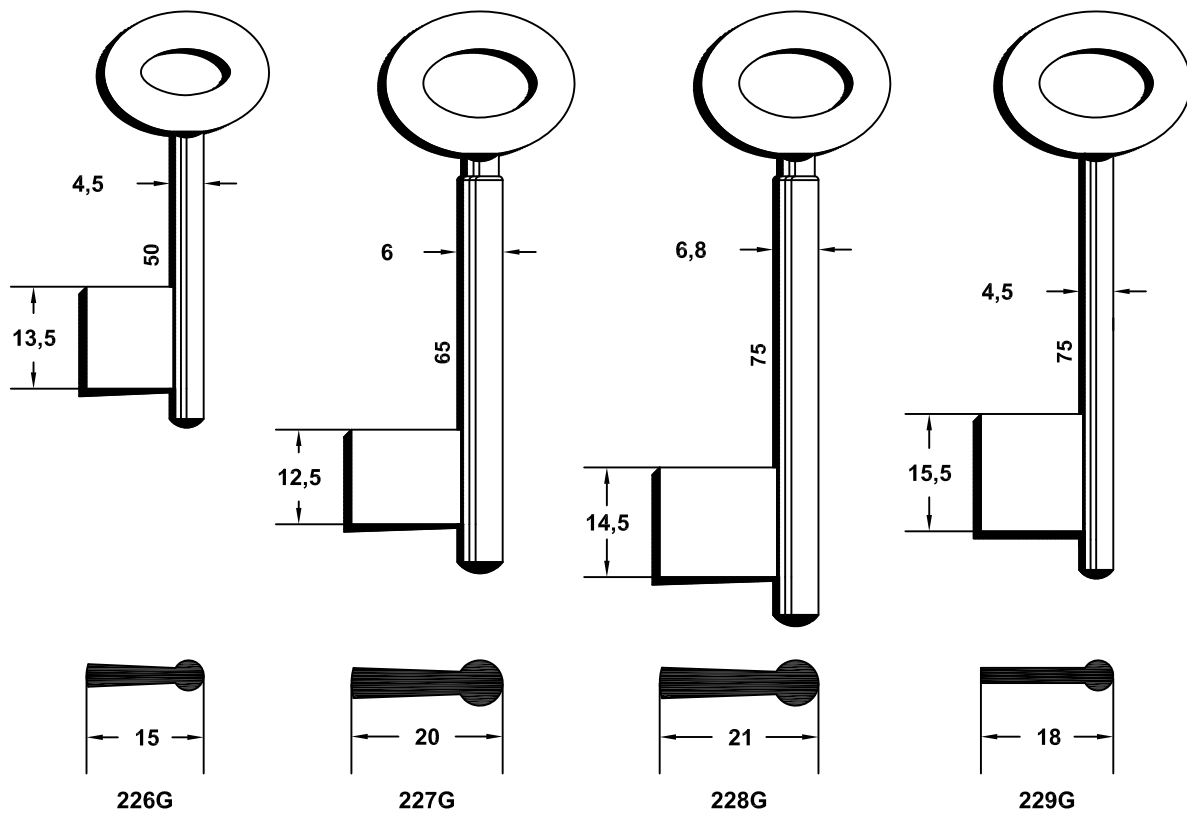

**PARA-FOR:**  
BOINAITI (I)

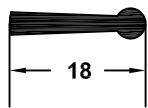
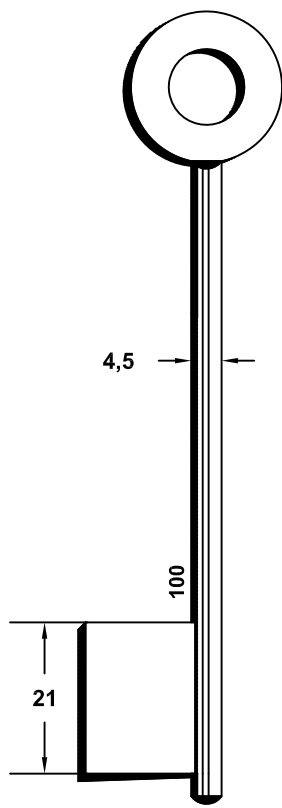

234G

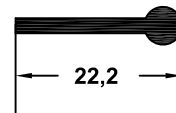
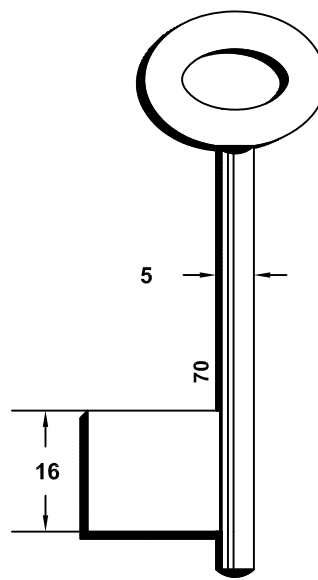

236G

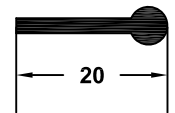
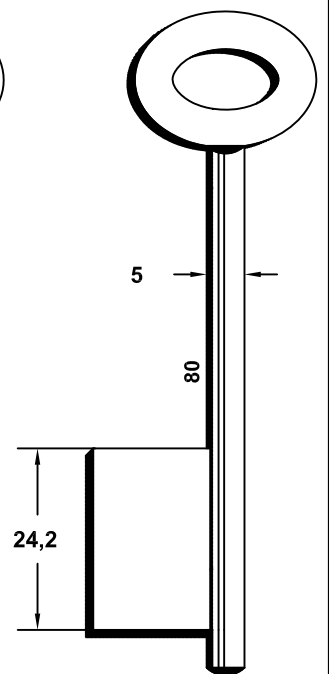

237G

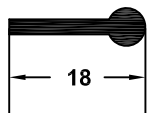
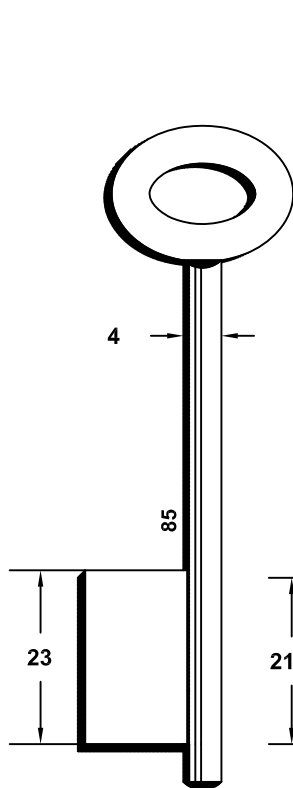

238G

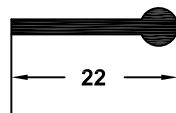
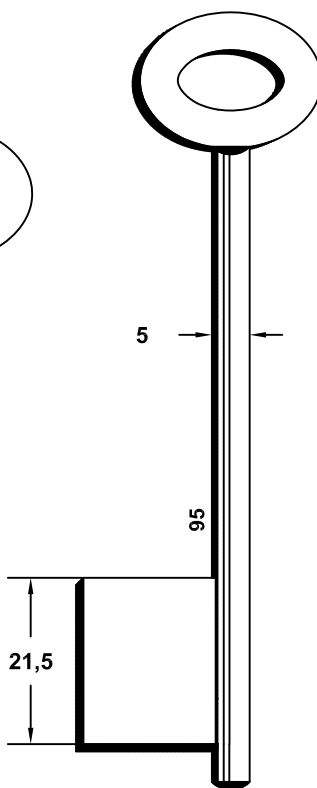

239G

**BOINAITI**

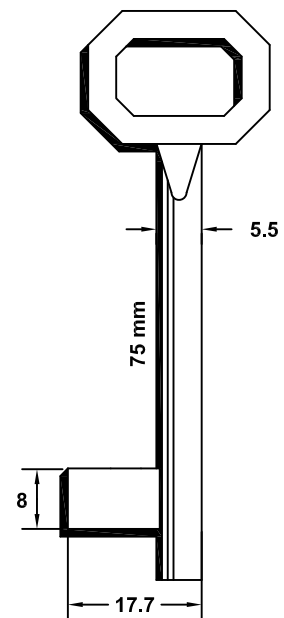

BON-3G



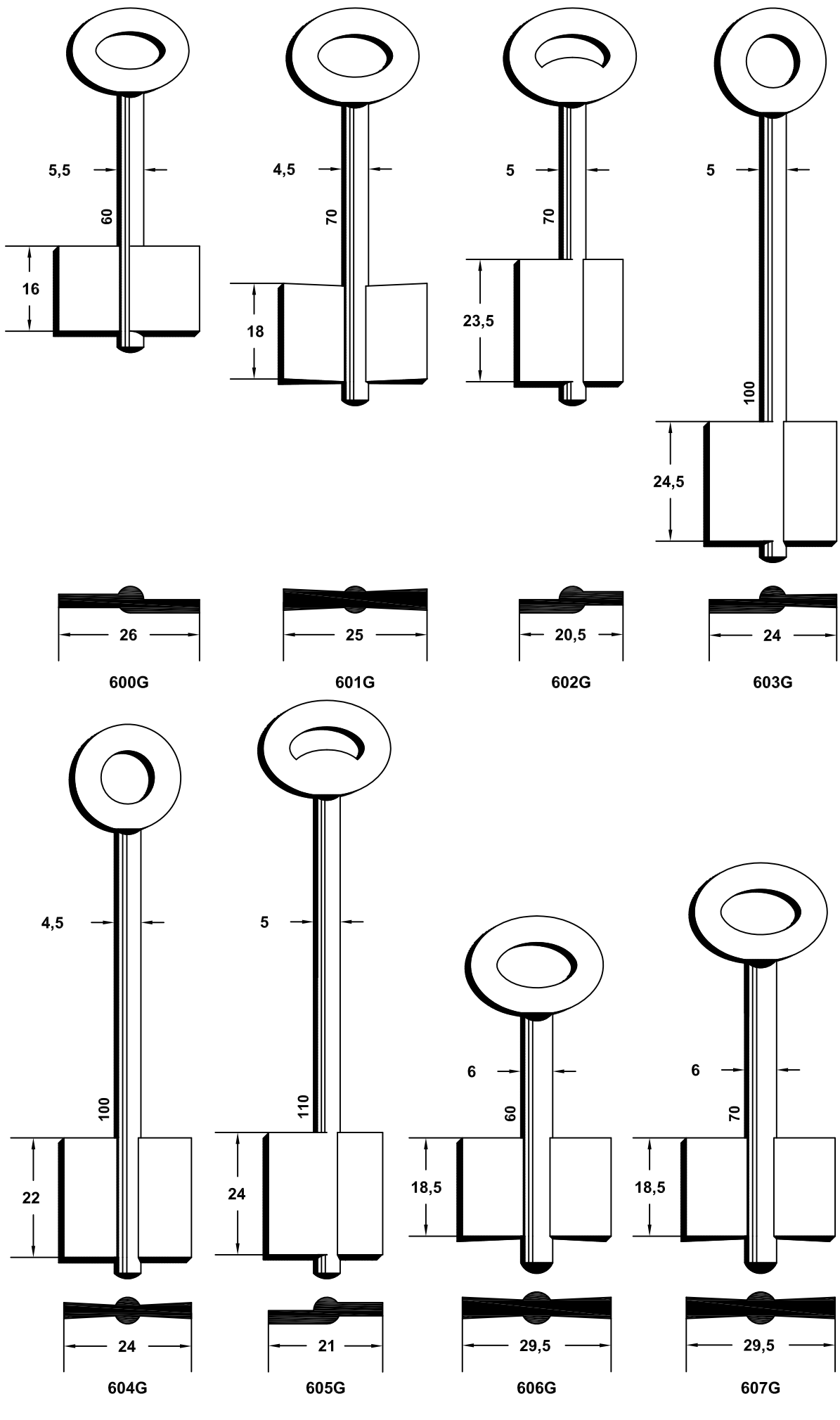

PARA-FOR:

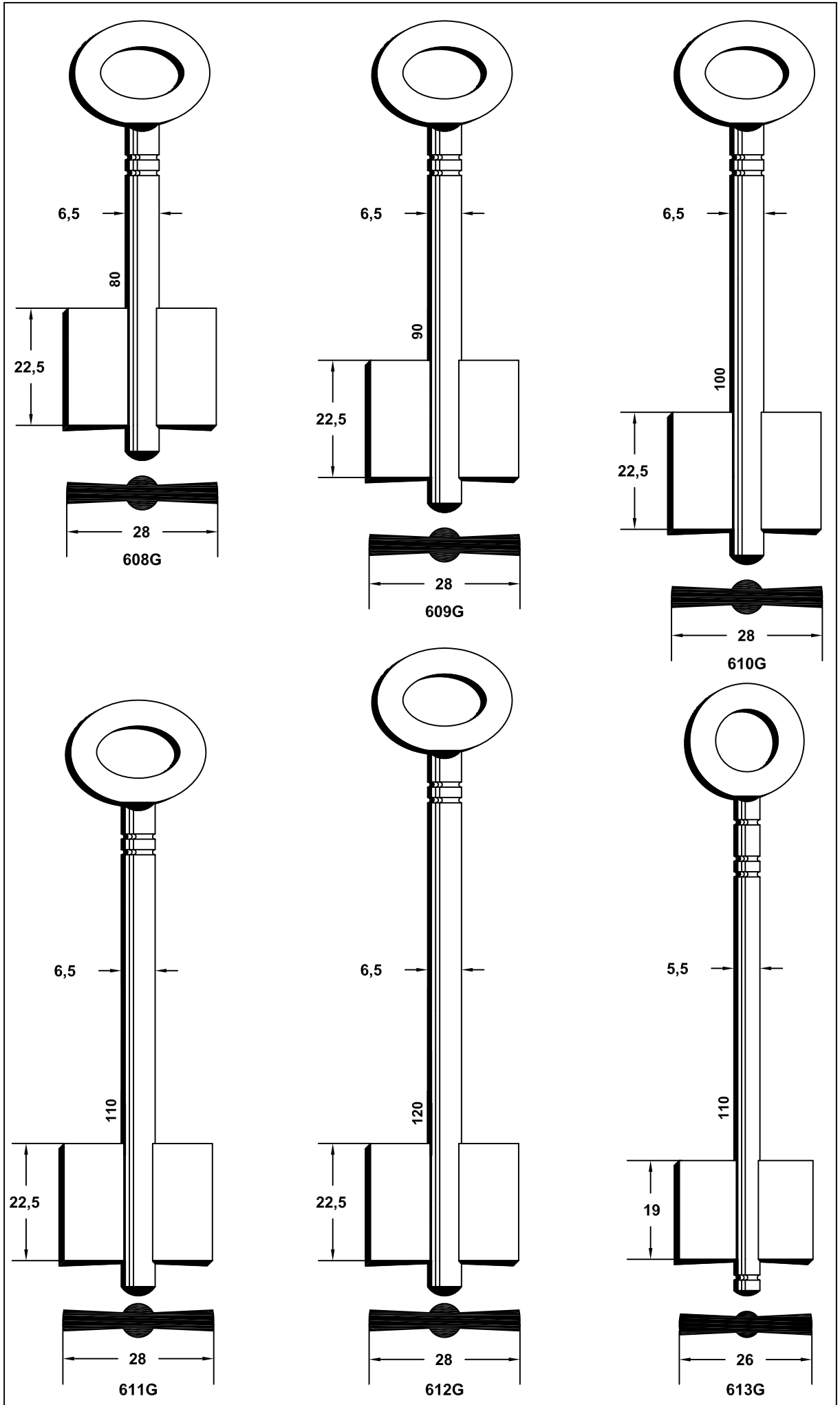



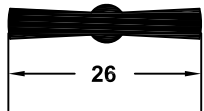
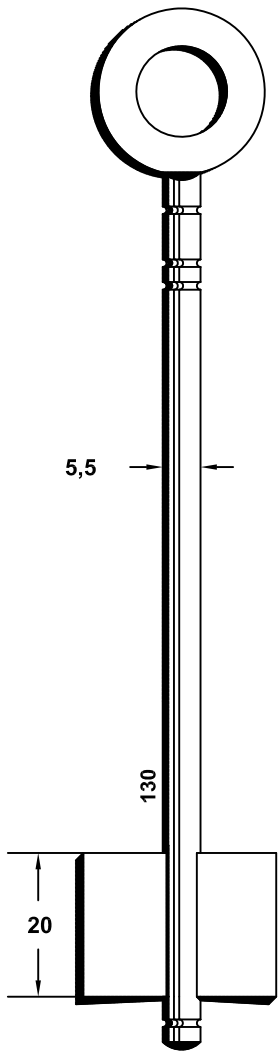

614G

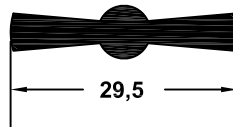
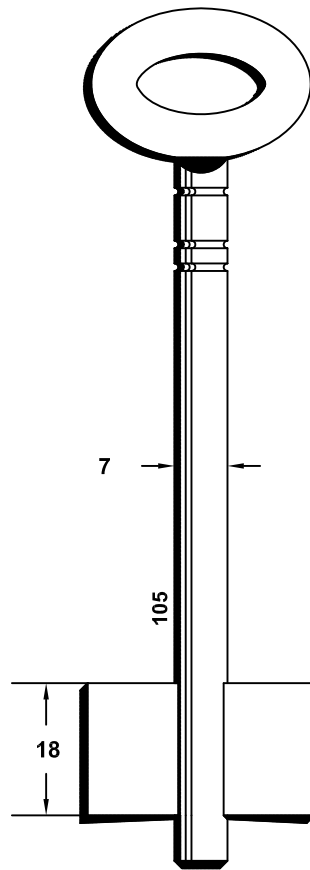

615G

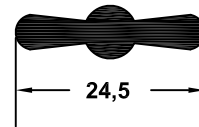
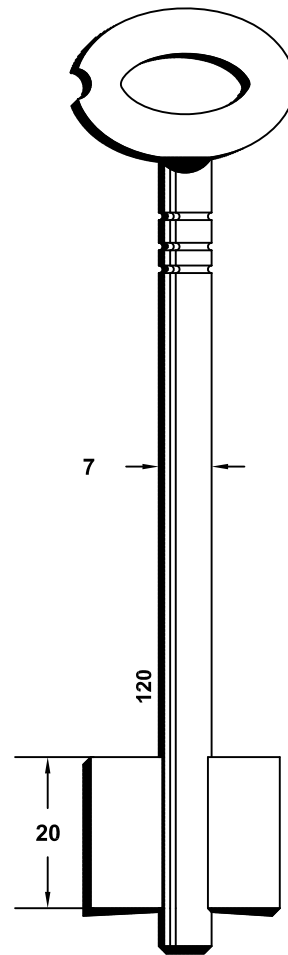

616G

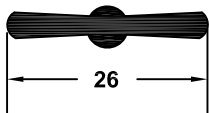
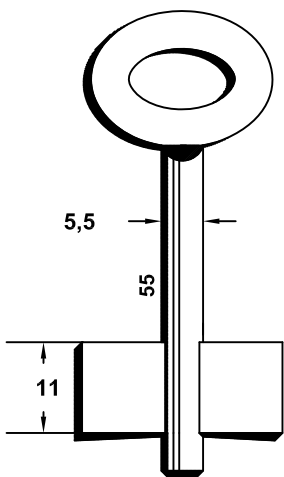

618G

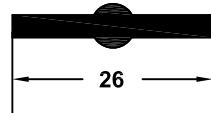
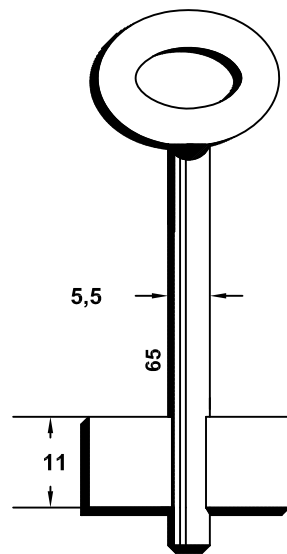

619G

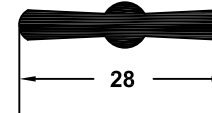
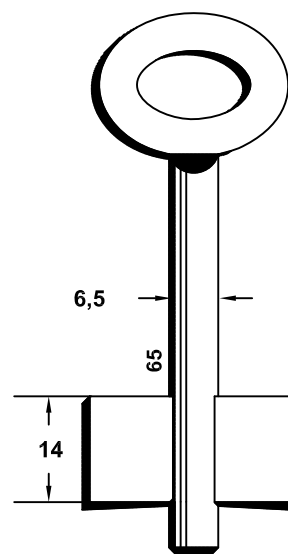

620G



PARA-FOR:

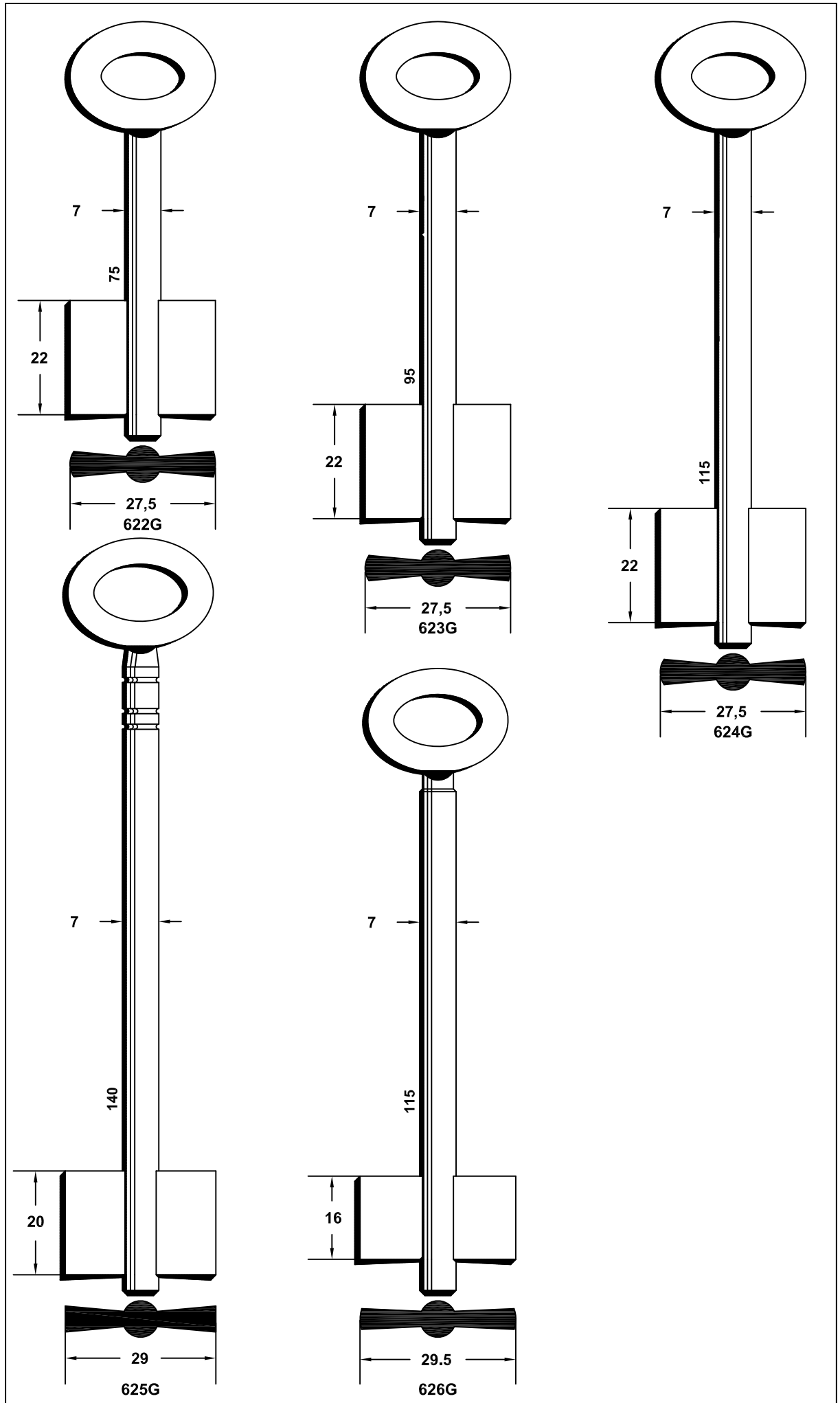

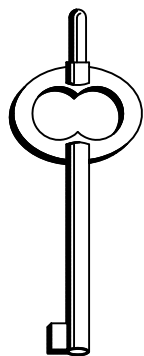

74G

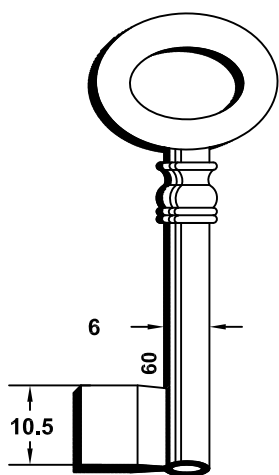

1200G

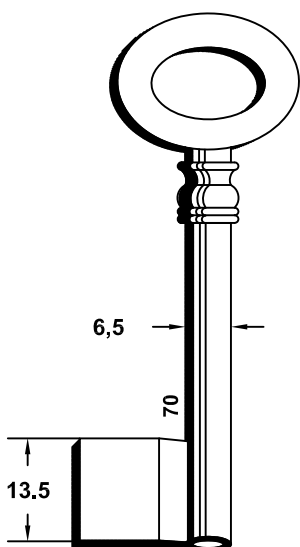
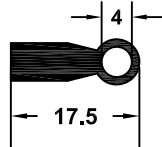

1201G

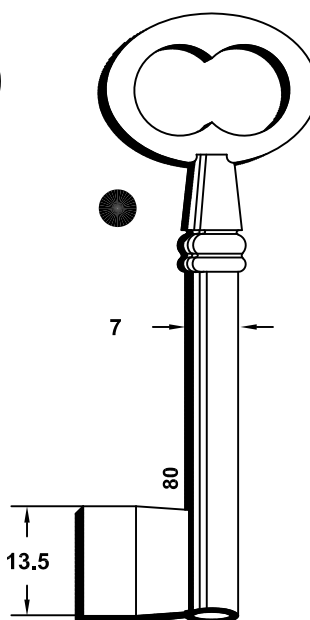
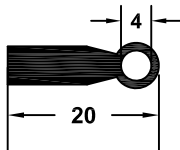

1202G

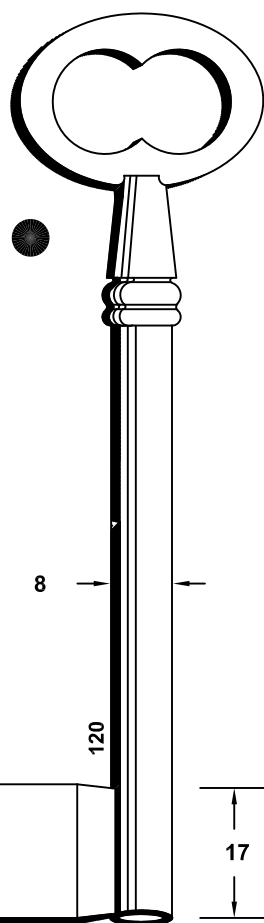
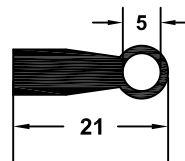

1206G

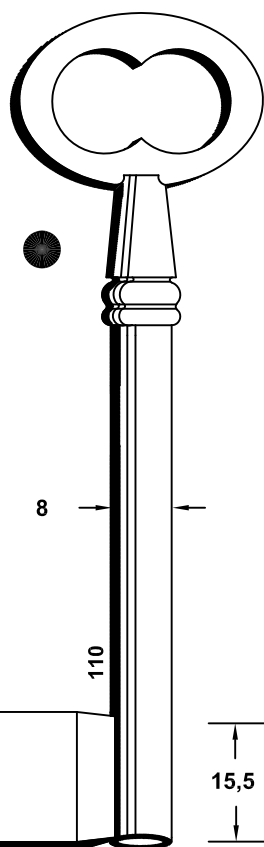
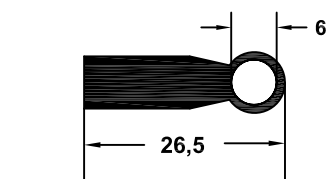

1205G

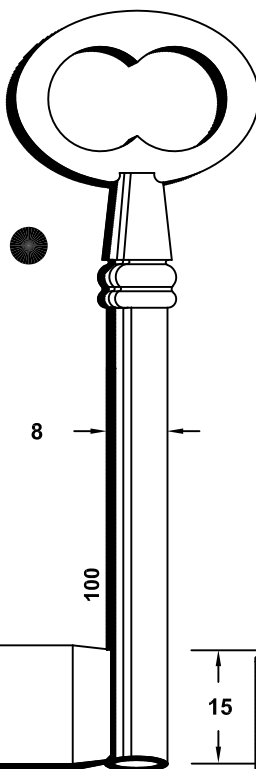
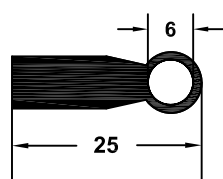

1204G

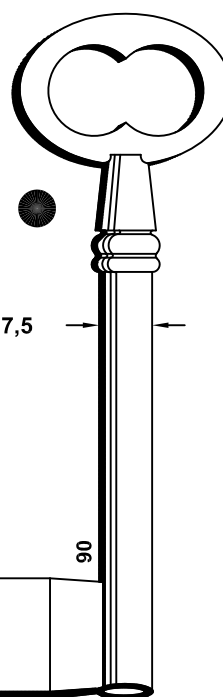
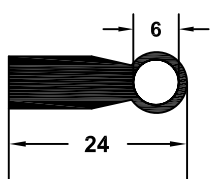

1203G

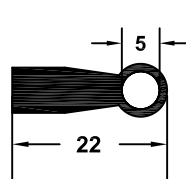

PARA-FOR:

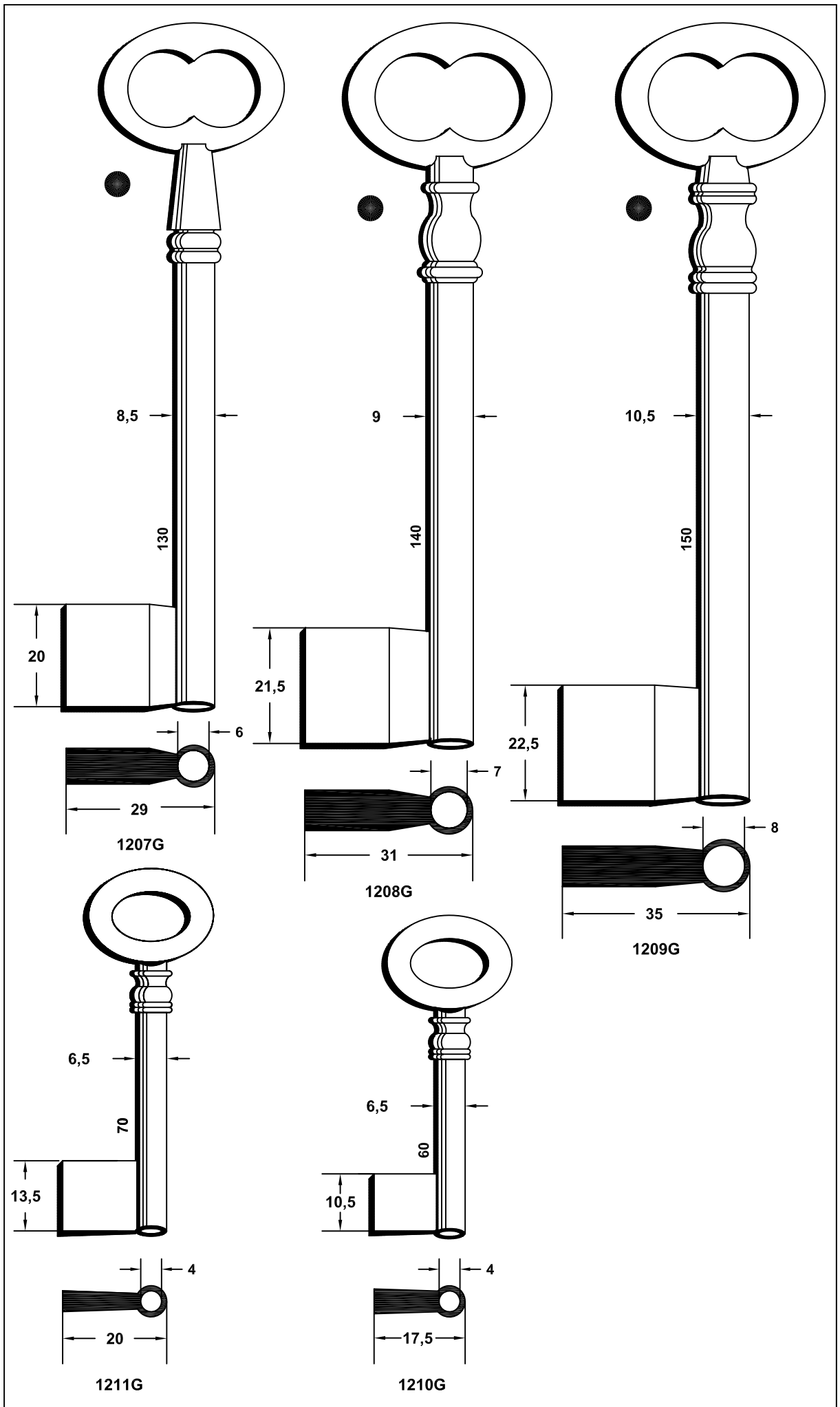

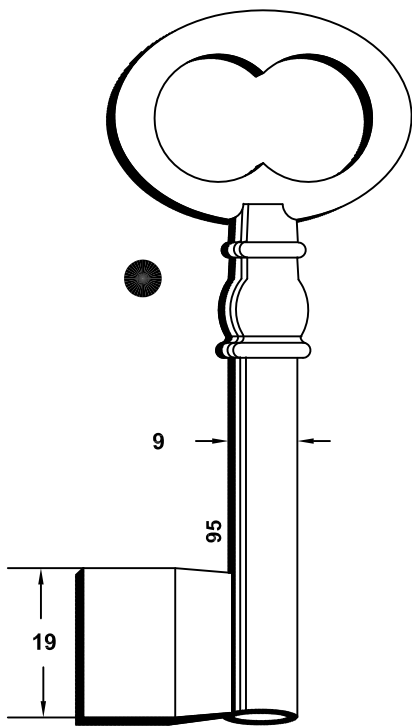

1212G

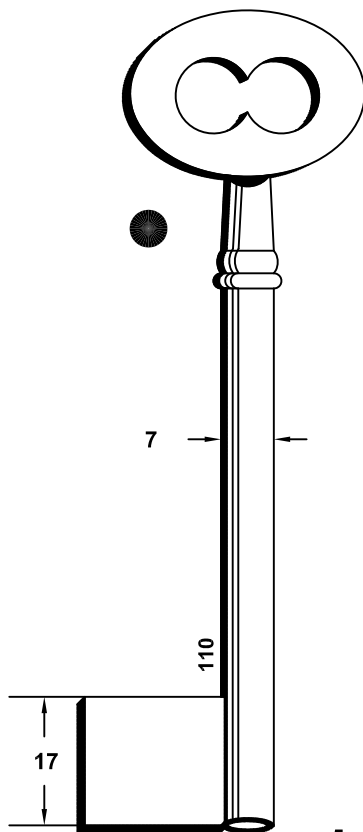

1213G

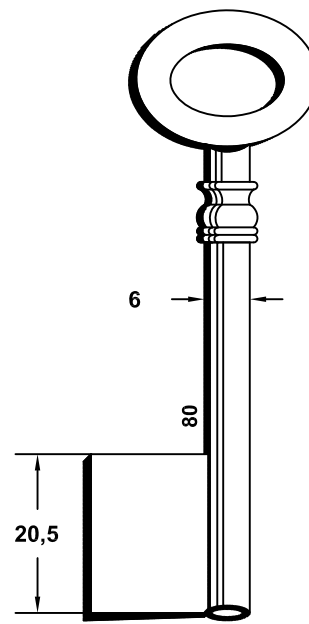

1214G

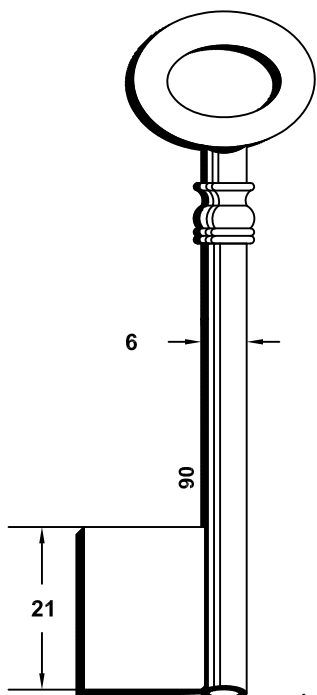

1215G

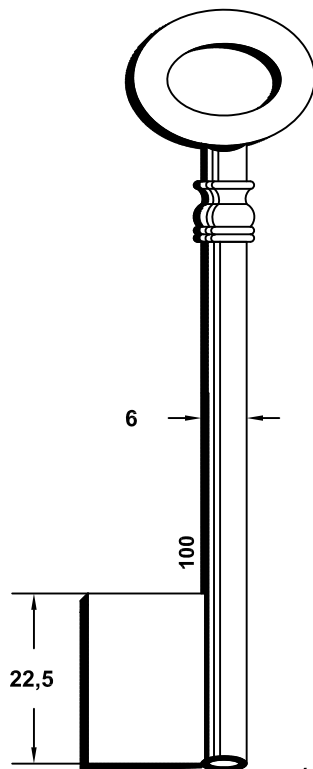

1216G

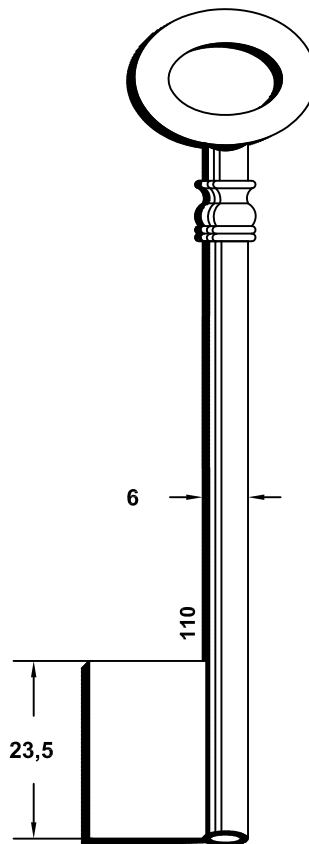

1217G



PARA-FOR:

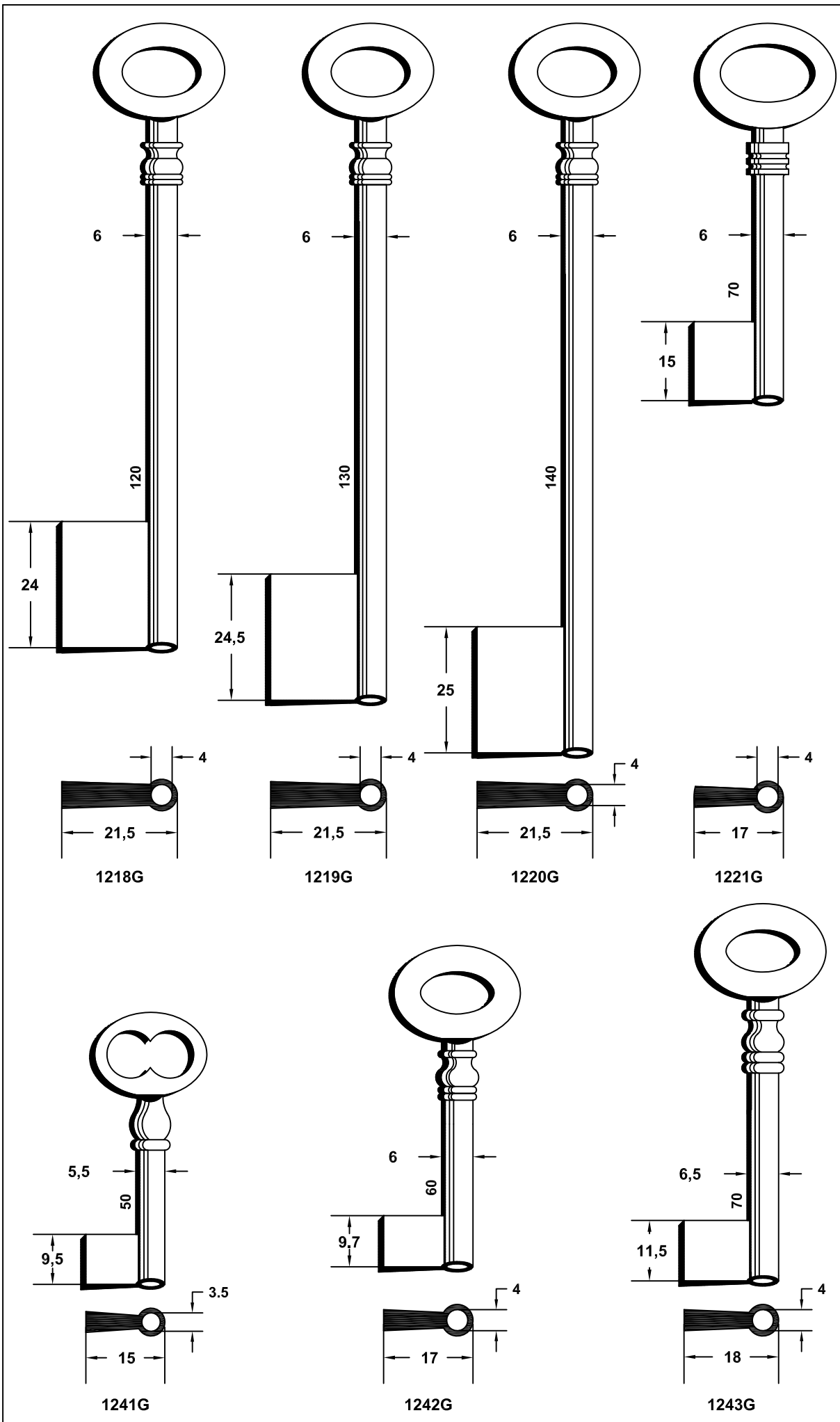

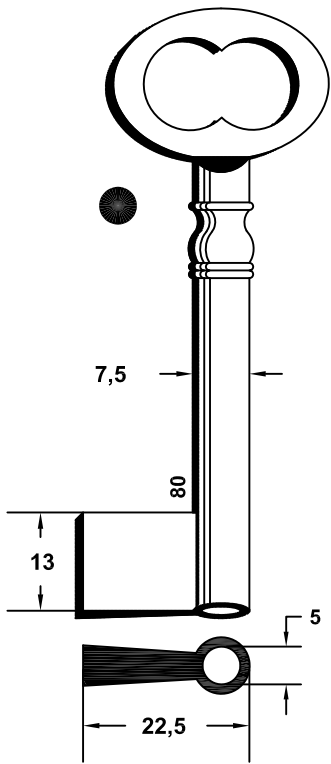

1244G

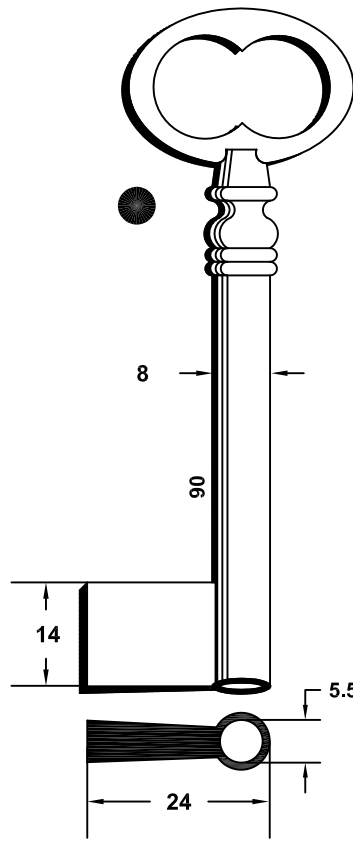

1245G

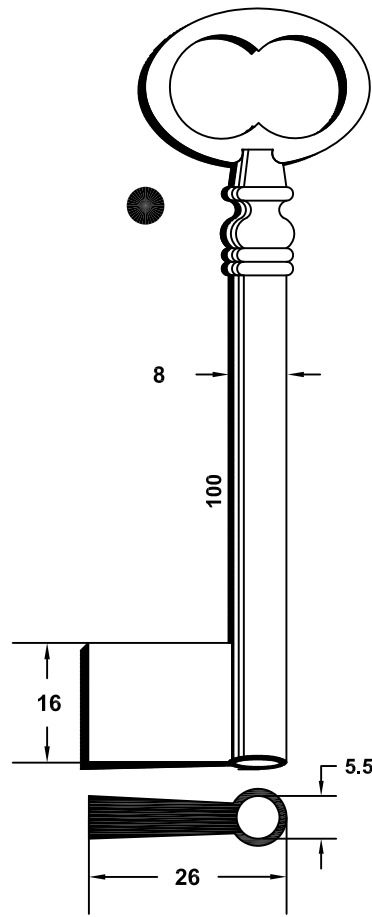

1246G

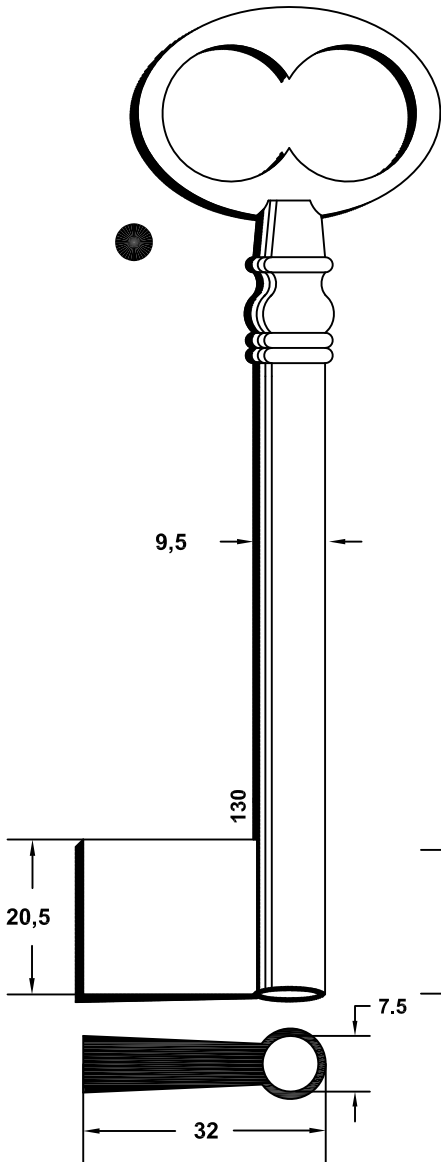

1249G

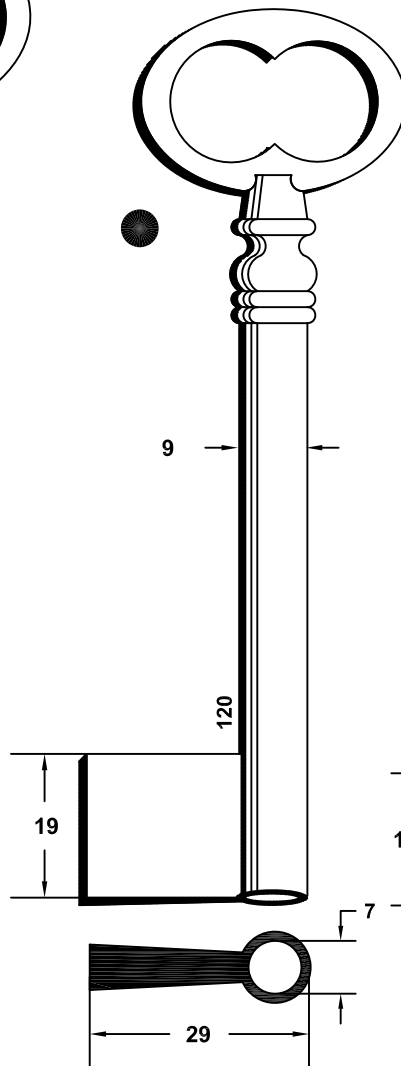

1248G

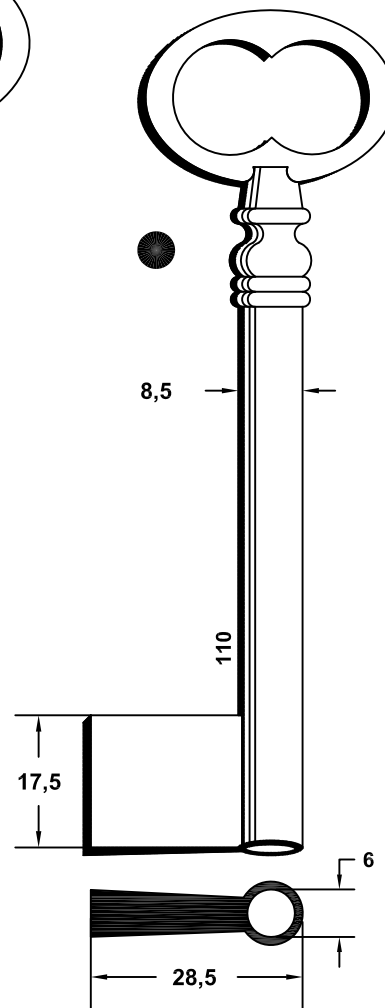

1247G



PARA-FOR:

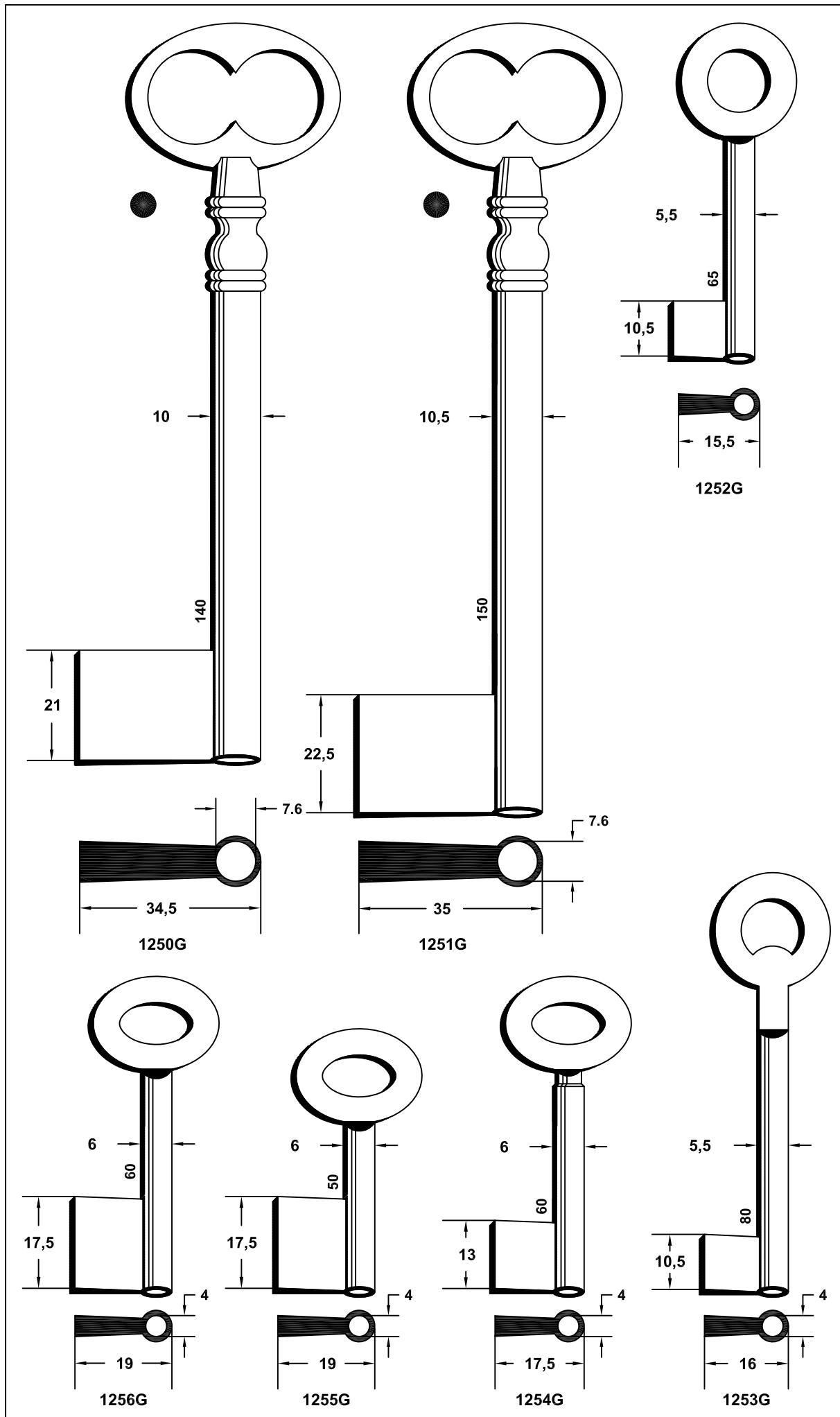



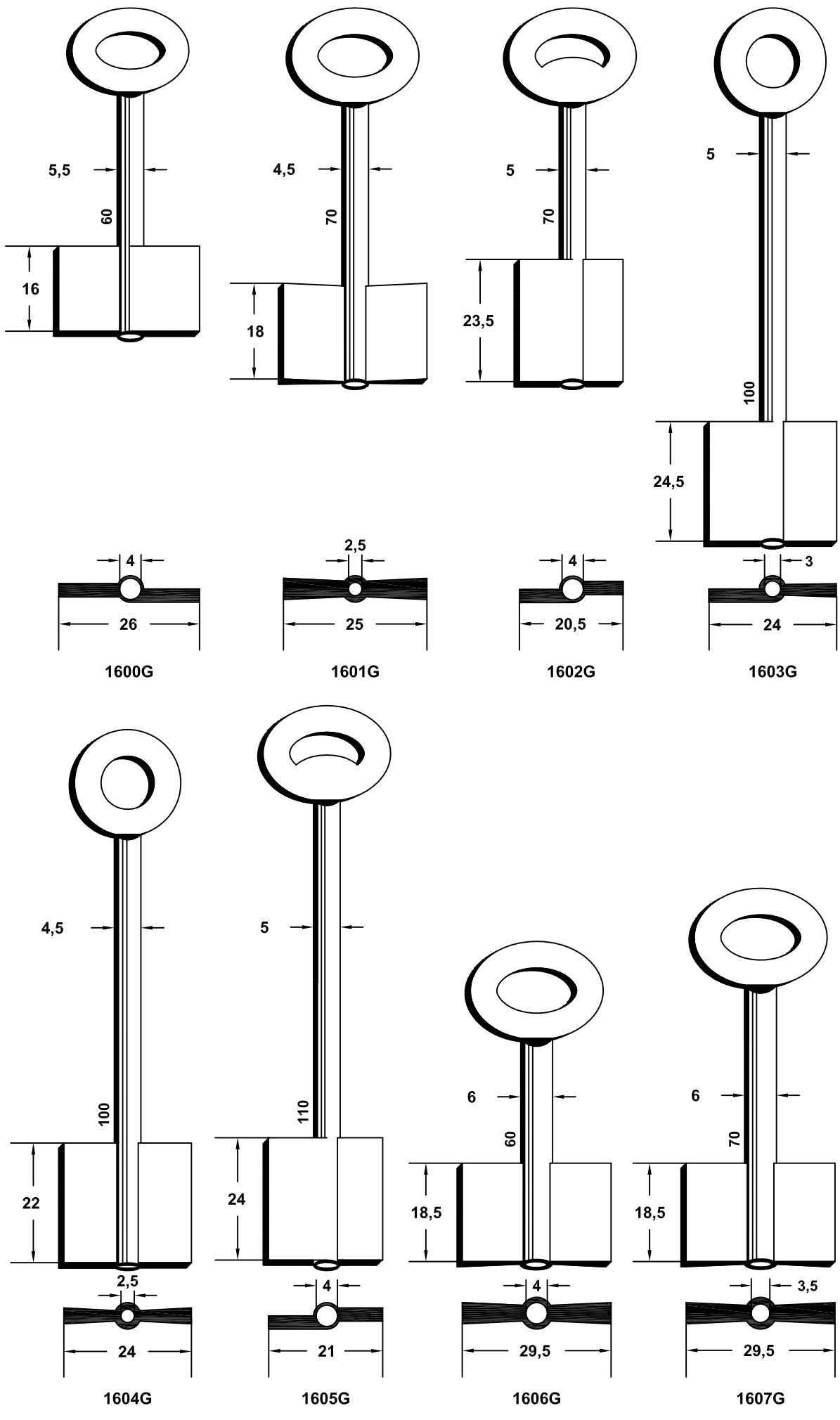

PARA-FOR:

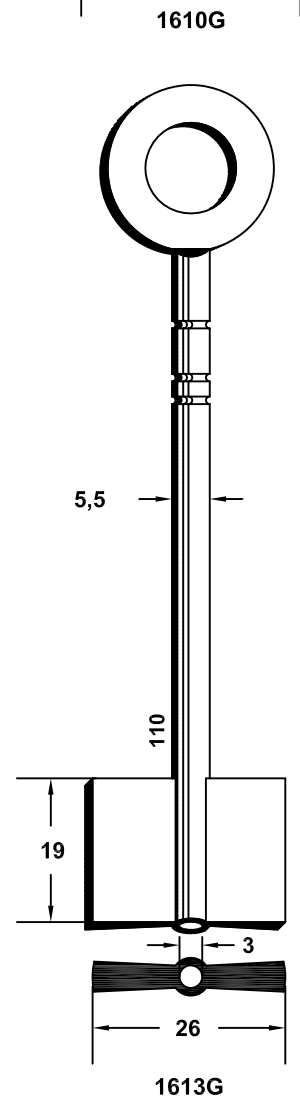
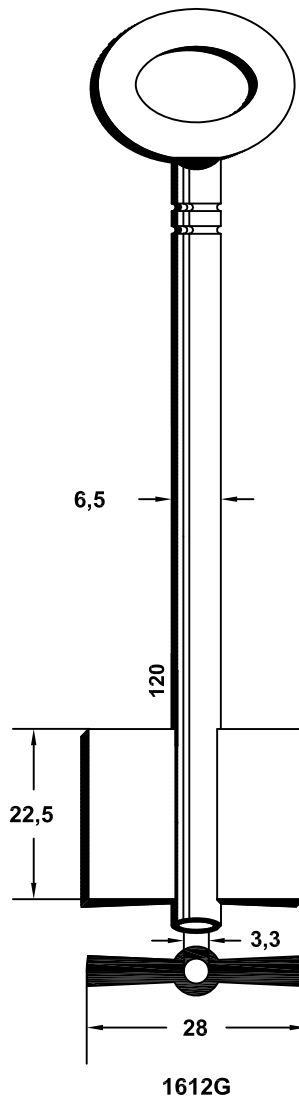
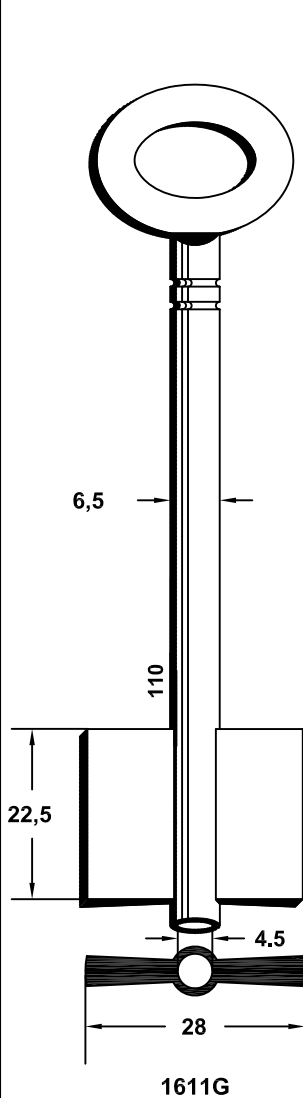
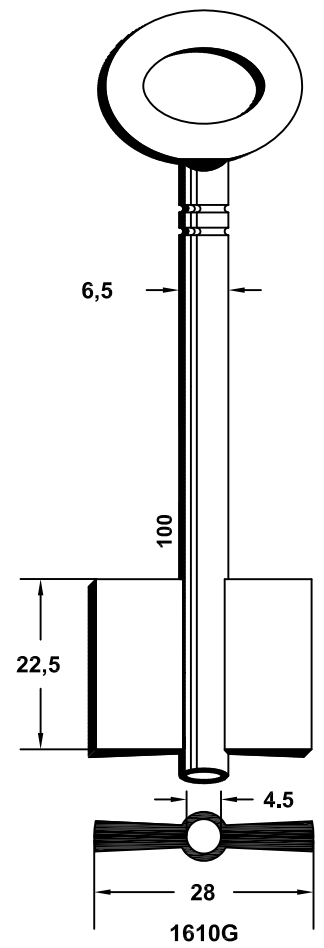
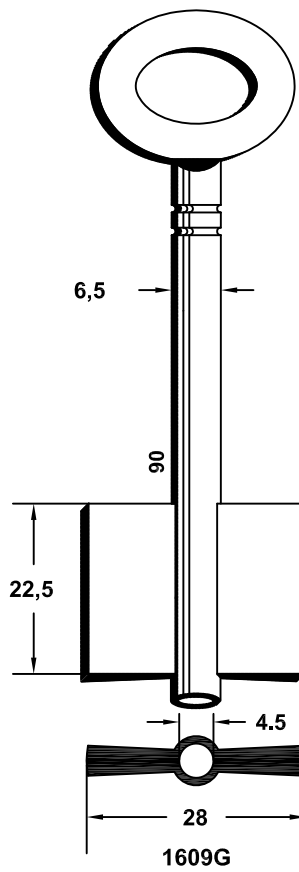
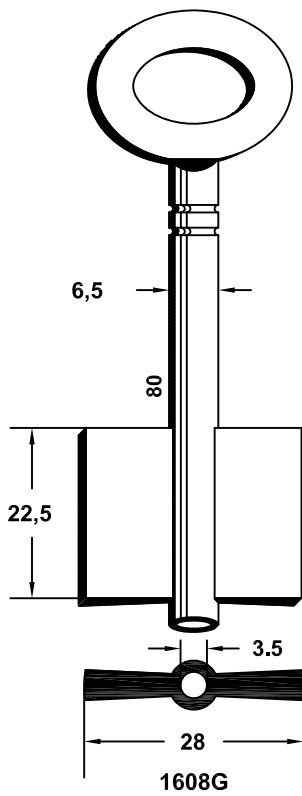

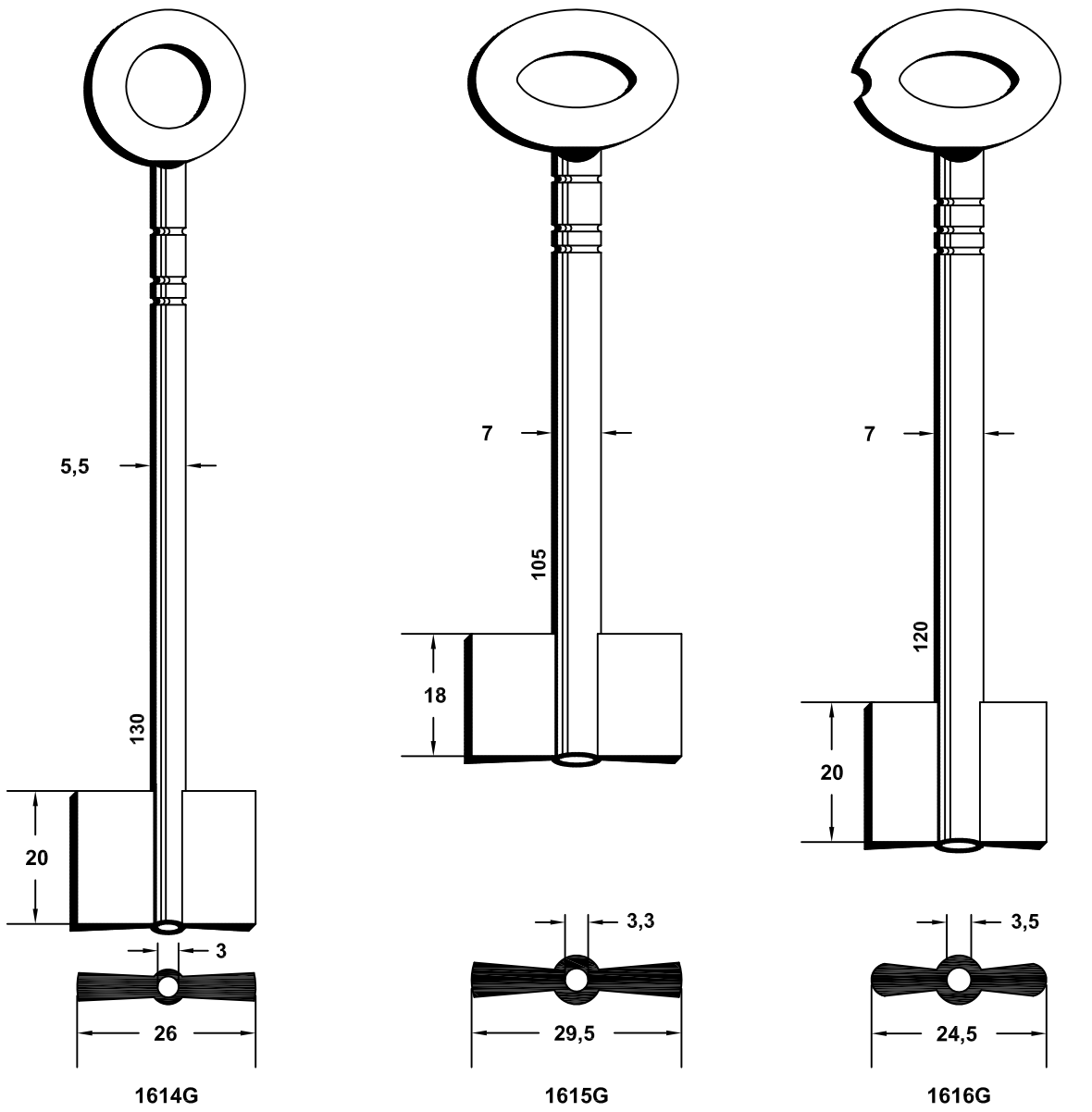

1614G

1615G

1616G

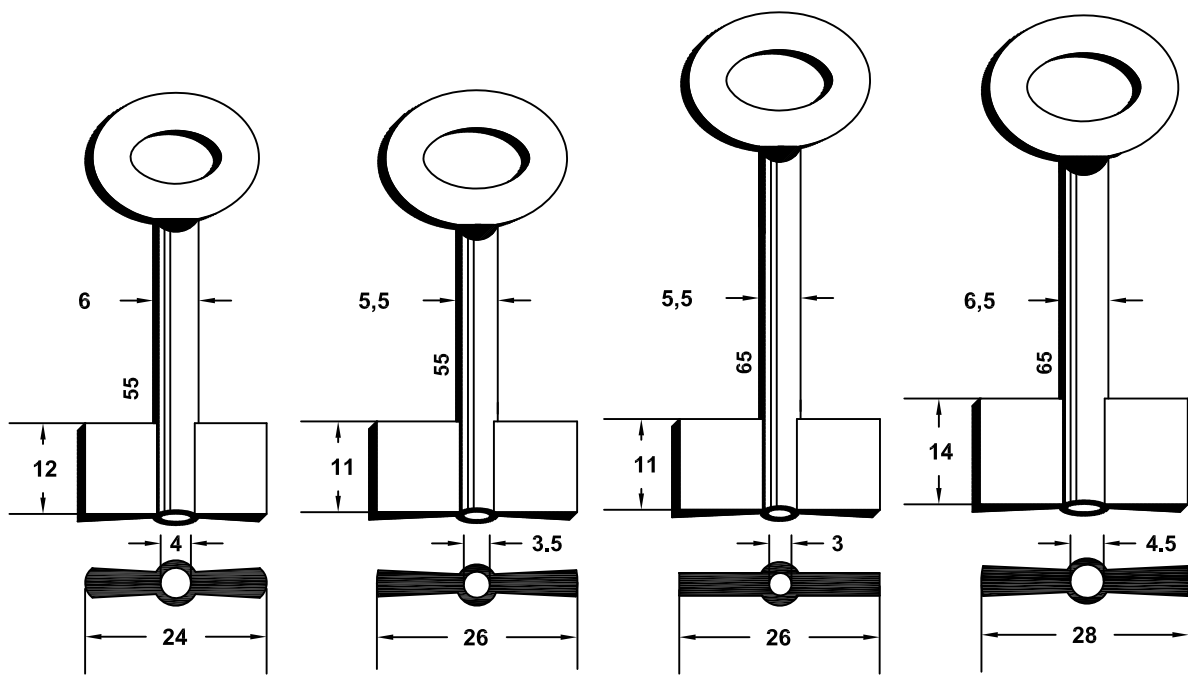

1617G

1618G

1619G

1620G



PARA-FOR:

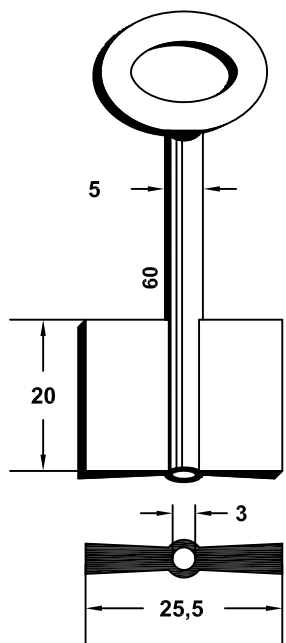

1621G

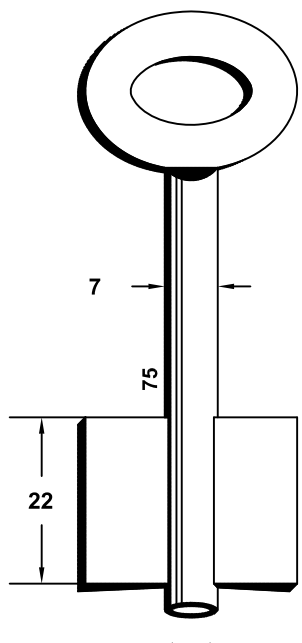

1622G

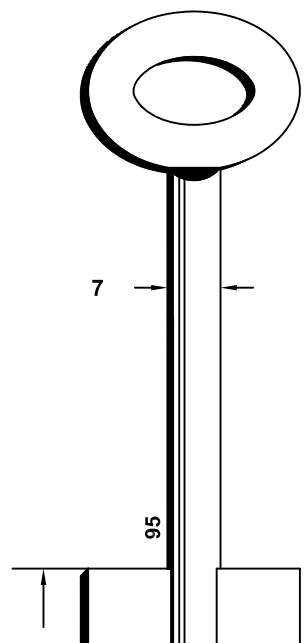

1623G

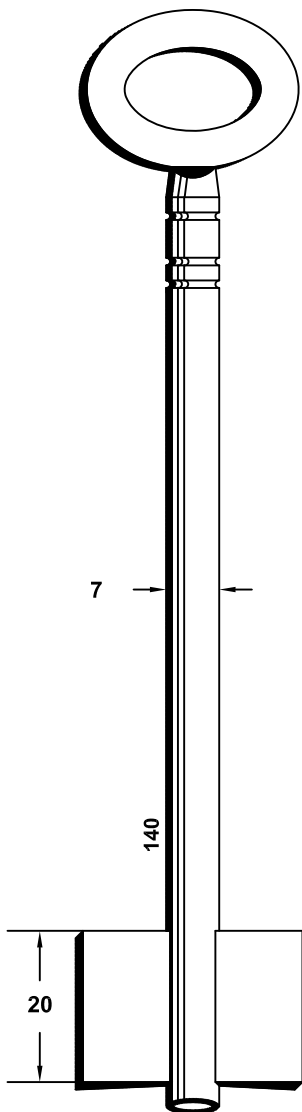

1625G

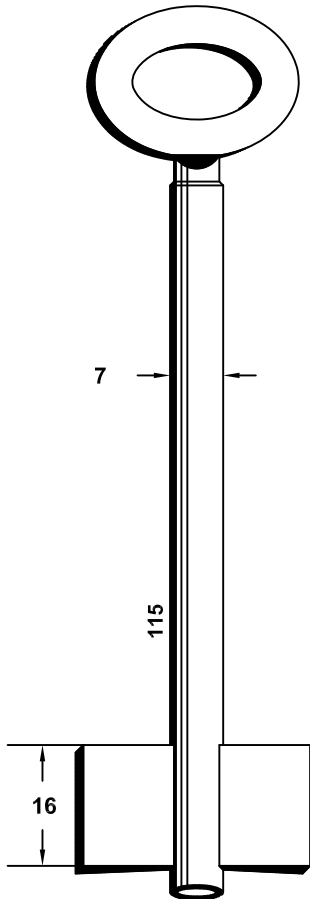

1626G

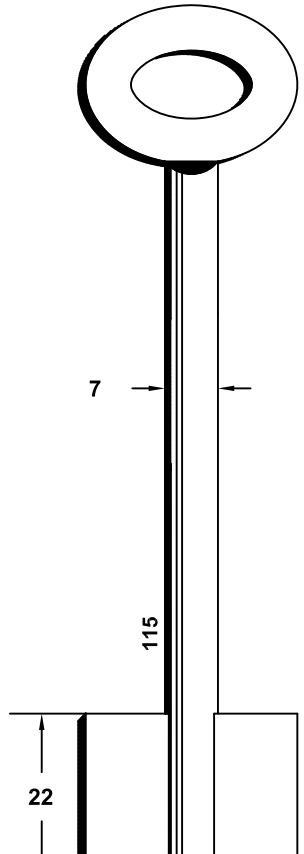

1624G



# ***LLAVES DE GORJA LATÓN***

*LETOIZKO GORJA GILTZAK*

*BRASS BIT KEYS*

*CLES A GORGES EN LAITON*

*CHUBBSCHLÜSSEL AUS MESSING*



***THE KEY TO EXCELLENCE***  
*GLOBALLY UNLOCKING MILLIONS OF DOORS DAILY*

PARA-FOR:

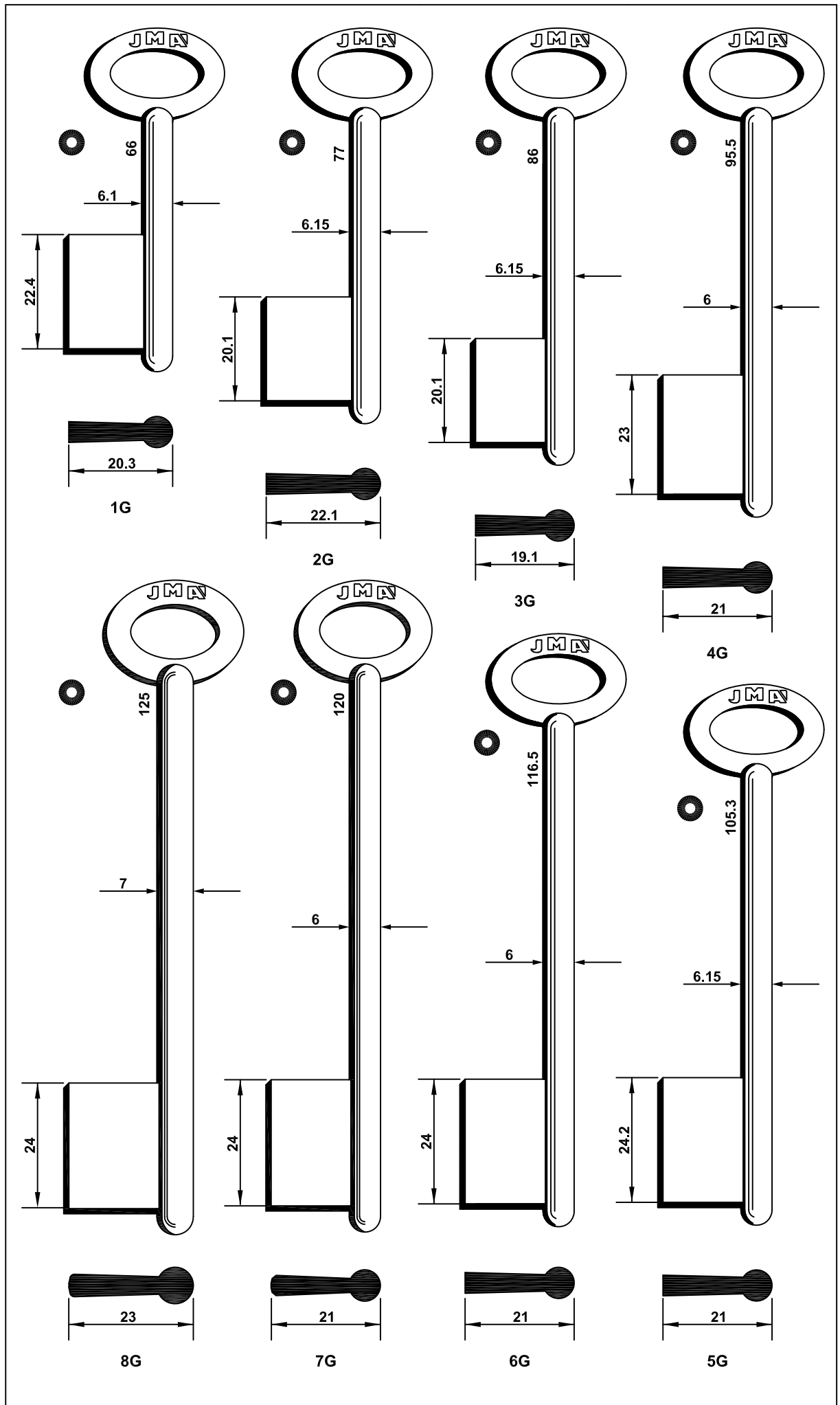

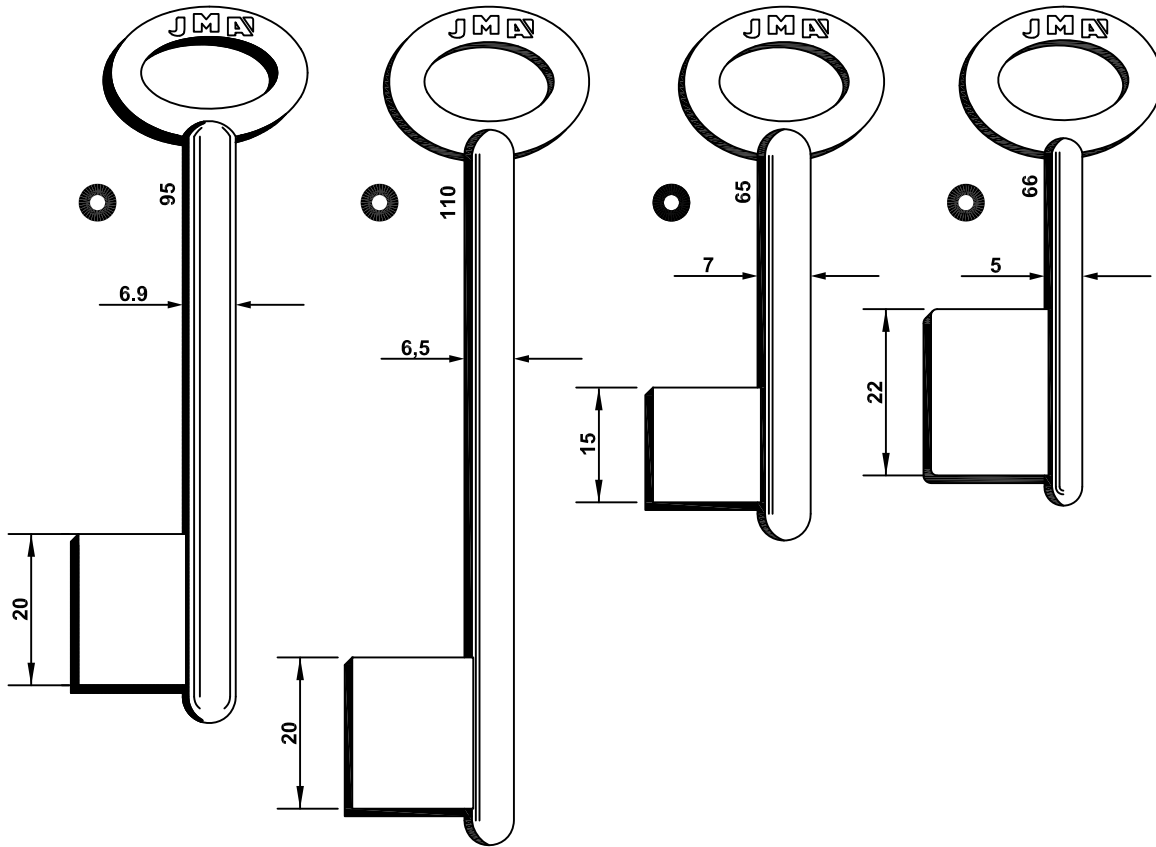

11G

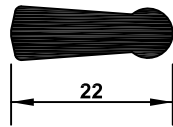

12G

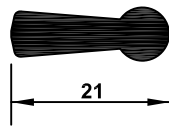

13G

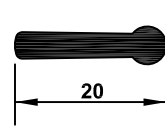

14G

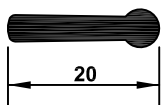
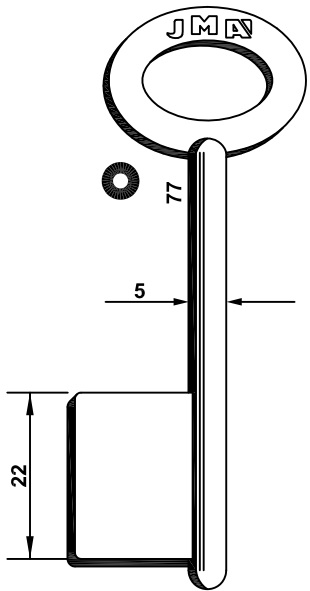

15G

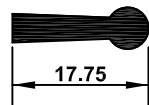
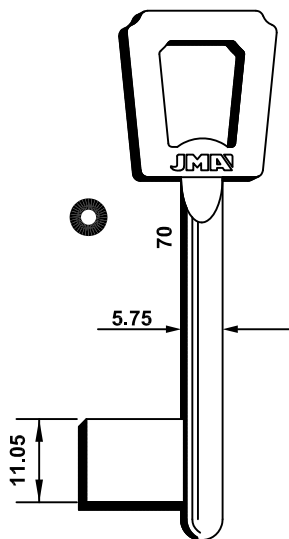

16G

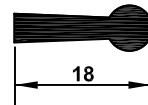
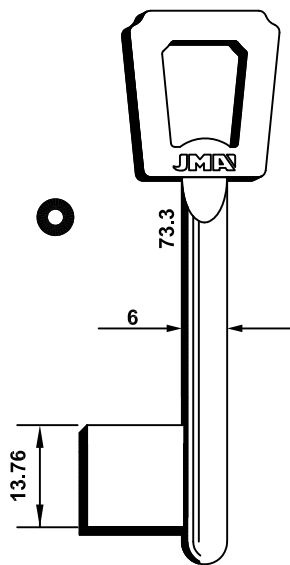

17G



PARA-FOR:

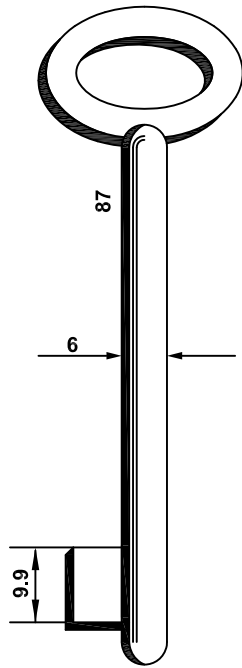

19G

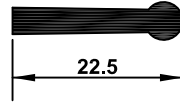
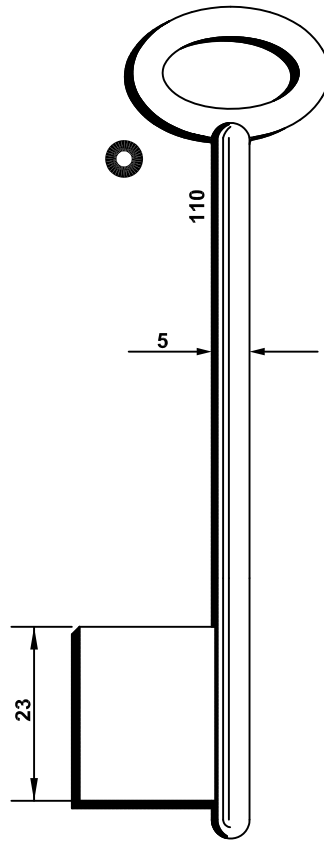

21G

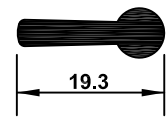
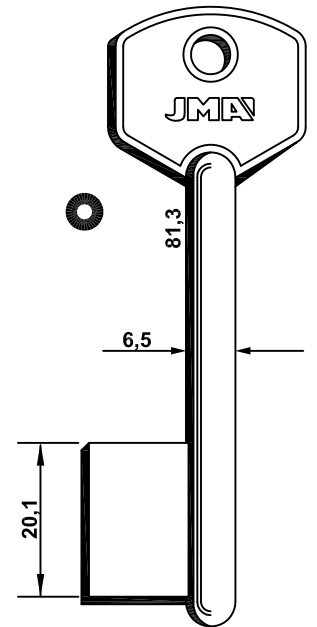

23G

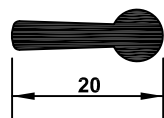
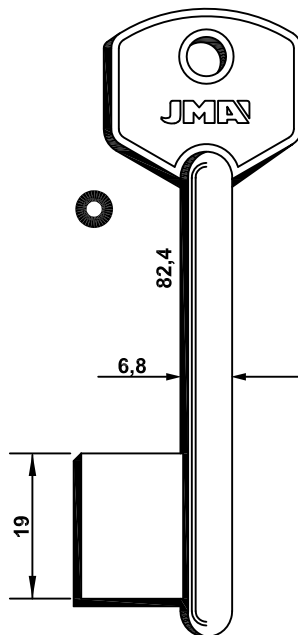

24G

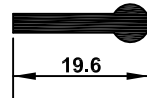
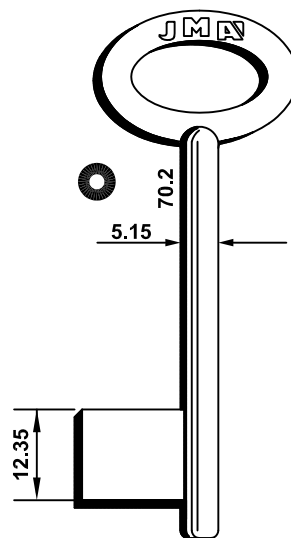

25G





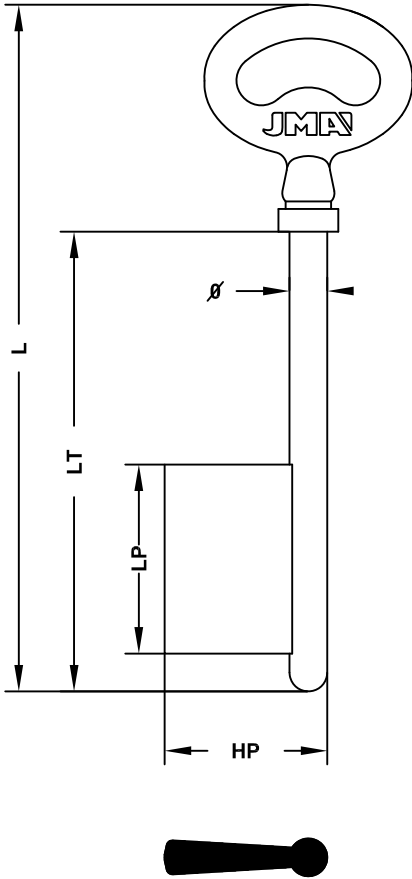

| REF.  | Ø   | L   | LT  | LP | HP   |
|-------|-----|-----|-----|----|------|
| AD-3  | 5   | 90  | 60  | 25 | 21,5 |
| AD-4  | 5   | 95  | 65  | 25 | 21,5 |
| AD-5  | 5   | 100 | 70  | 25 | 21,5 |
| AD-16 | 5   | 110 | 80  | 30 | 21,5 |
| AD-17 | 5   | 120 | 89  | 35 | 21,5 |
| AD-6  | 5,5 | 80  | 59  | 25 | 22   |
| AD-7  | 5,5 | 95  | 64  | 25 | 22   |
| AD-18 | 5,5 | 95  | 64  | 30 | 22   |
| AD-8  | 5,5 | 100 | 70  | 25 | 21,5 |
| AD-19 | 5,5 | 110 | 80  | 30 | 22   |
| AD-20 | 5,5 | 120 | 89  | 35 | 22   |
| AD-1  | 5,8 | 75  | 43  | 18 | 14   |
| AD-9  | 5,8 | 80  | 50  | 25 | 19   |
| AD-21 | 5,8 | 95  | 65  | 30 | 22   |
| AD-10 | 6   | 90  | 59  | 25 | 22   |
| AD-11 | 6   | 95  | 65  | 25 | 22   |
| AD-12 | 6   | 100 | 70  | 25 | 22   |
| AD-23 | 6   | 110 | 80  | 30 | 22   |
| AD-24 | 6   | 120 | 88  | 35 | 22   |
| AD-25 | 6   | 140 | 108 | 35 | 22   |
| AD-26 | 6,5 | 95  | 65  | 30 | 23   |
| AD-13 | 6,5 | 100 | 70  | 25 | 22   |
| AD-29 | 6,5 | 100 | 70  | 30 | 23   |
| AD-27 | 6,5 | 110 | 80  | 30 | 23   |
| AD-28 | 6,5 | 120 | 90  | 35 | 23   |

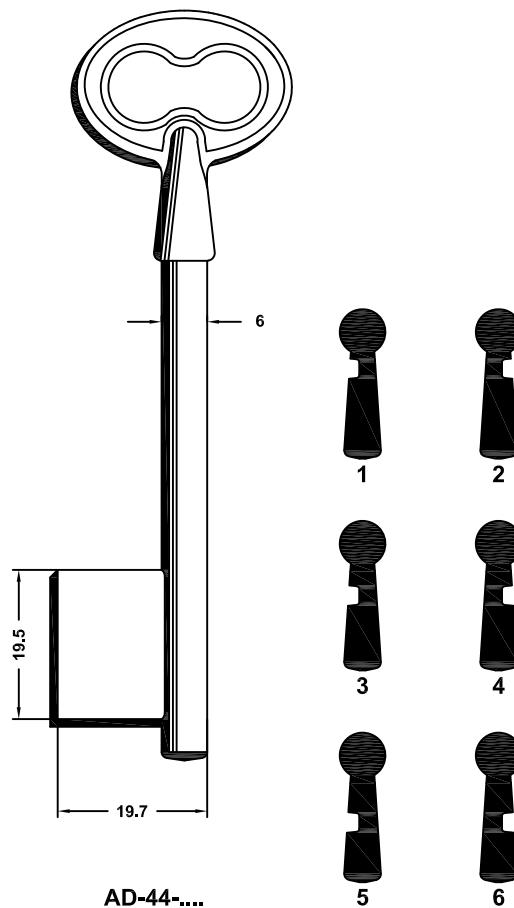
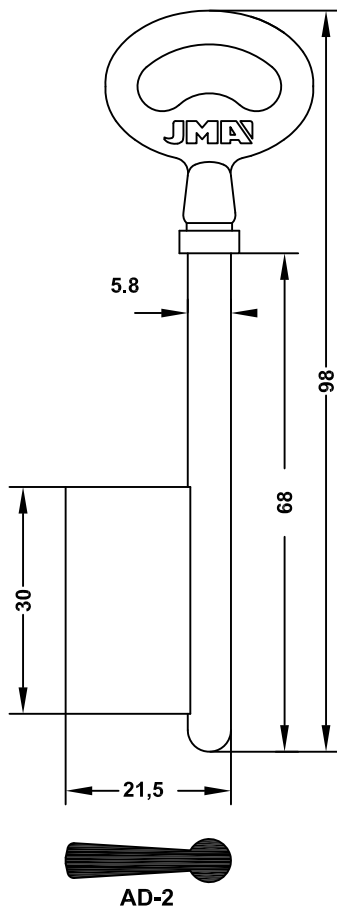

**PARA-FOR:**

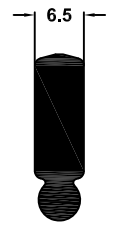

**ADPLE-11**

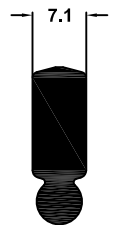
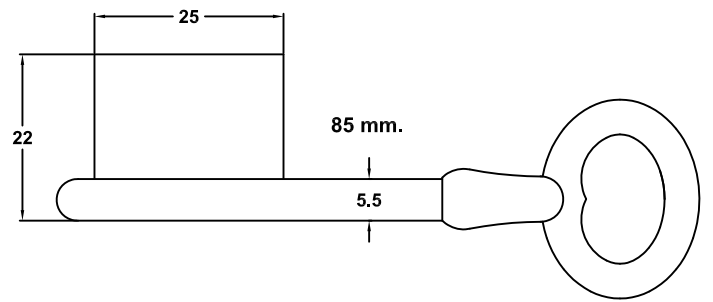

**ADPLE-22**

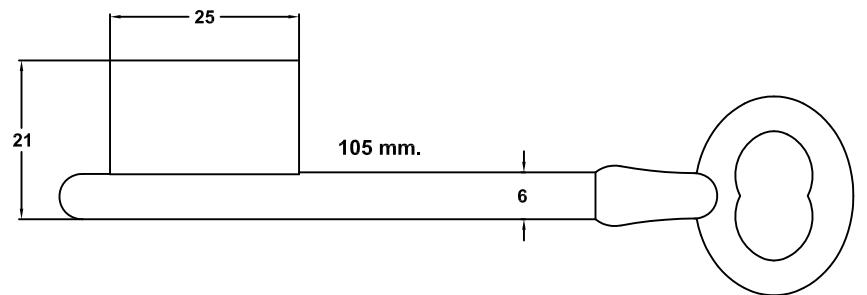

**ADPLE-33**

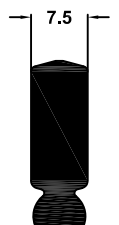
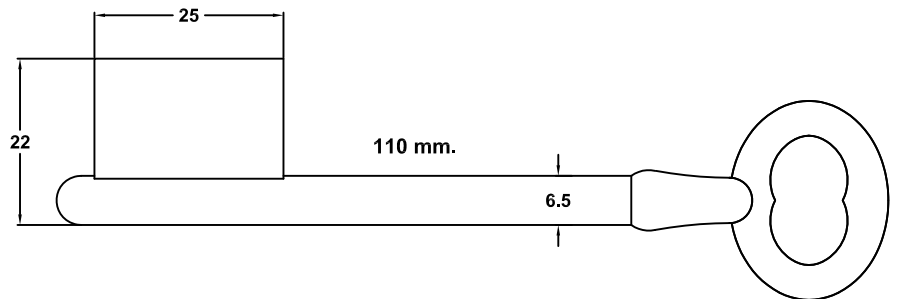

**ADPLE-44**

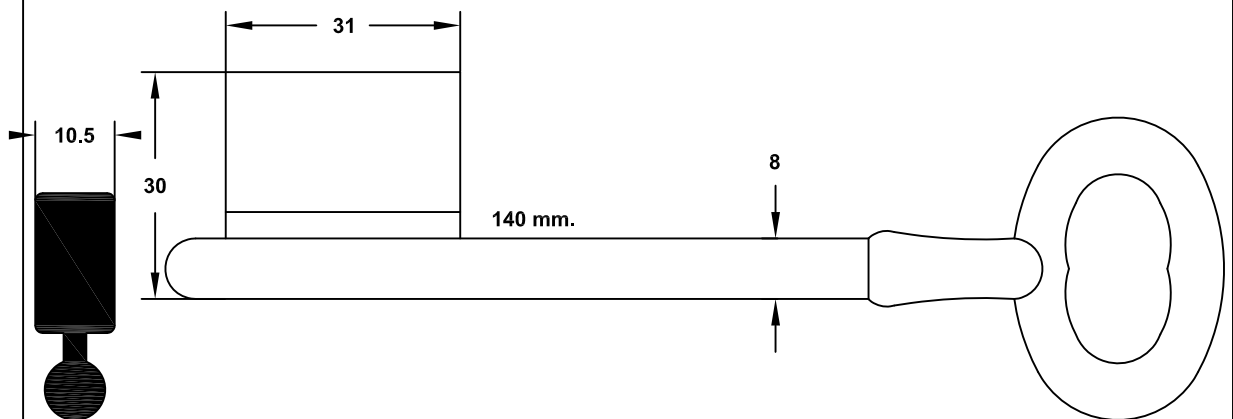
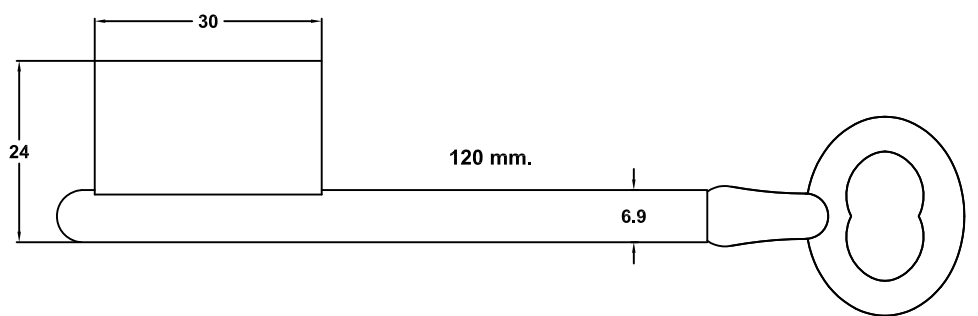

**ADPLE-55**



126

AGA

PARA-FOR:

126 (S)

AGA (E)

ASSA (S)

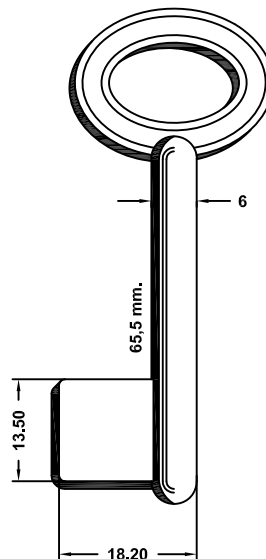
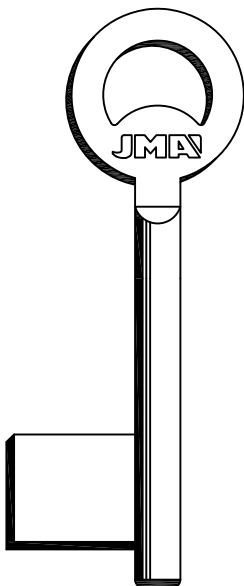
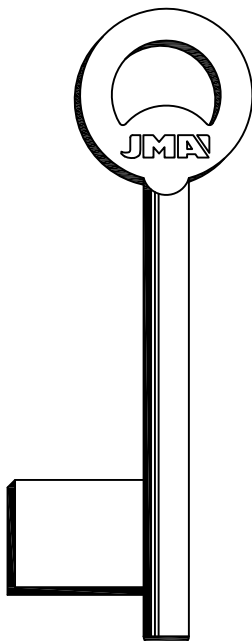
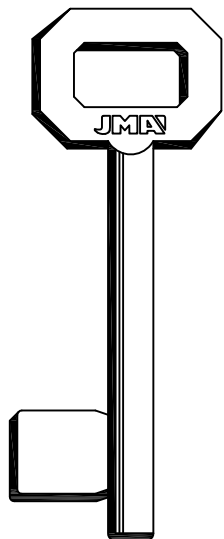

126H-60G



126N-60G



126PP-60G



AGA-1G

ASSA

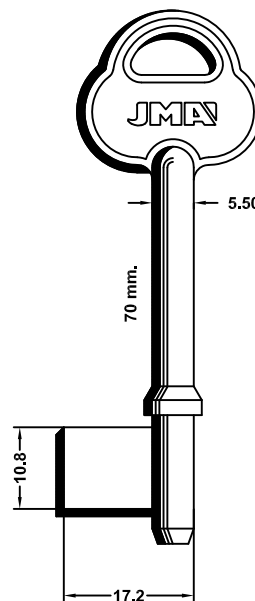
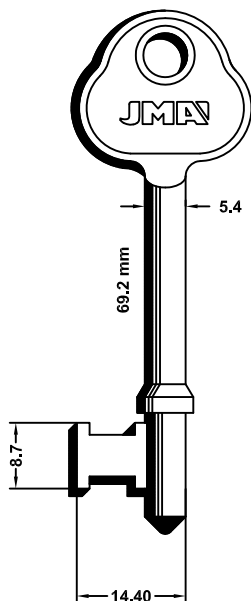
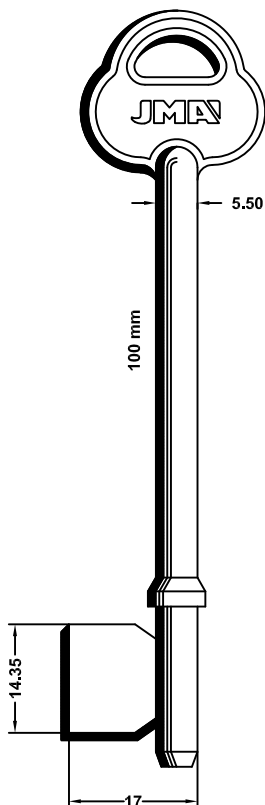
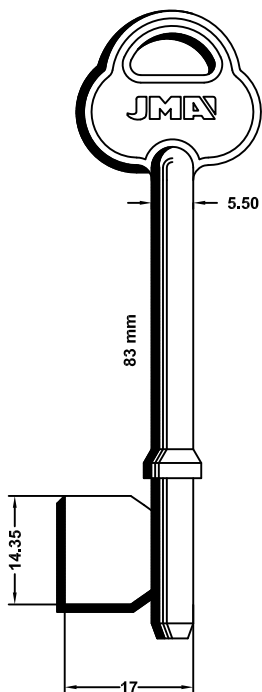

AS-1G



AS-2G



AS-3G



AS-6G/1



**PARA-FOR:**

ASSA (S)

BODA (SF)

BRICARD (F)

CHUBB (GB)

**ASSA**

AS-6G/2

**BODA**

BOD-4G

BOD-5G

**BRICARD**

BRI-6L...

**CHUBB**

CHU-1G

CHU-2G



# DAR-MAR

# PARA-FOR:

DAR-MAR (PL)

DEBEAURAIN (F)

ELZETT (H)

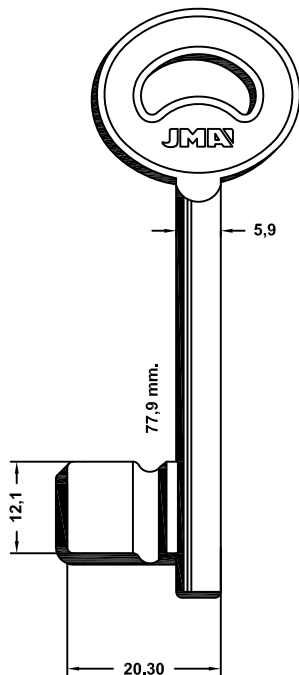
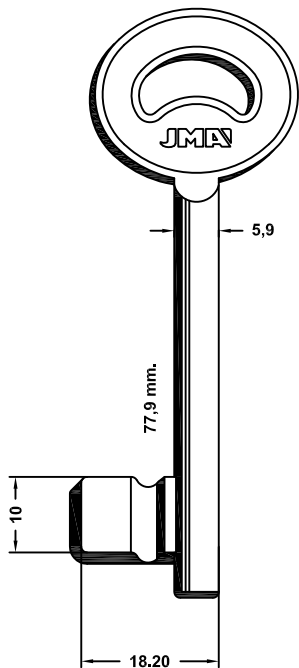

DMR-6-1



DMR-6-3



DMR-6-1L



DMR-6-3L



DMR-6-2



DMR-6-4



DMR-6-2L



DMR-6-4L

## DAR-MAR

## DEBEAURAIN

## ELZETT

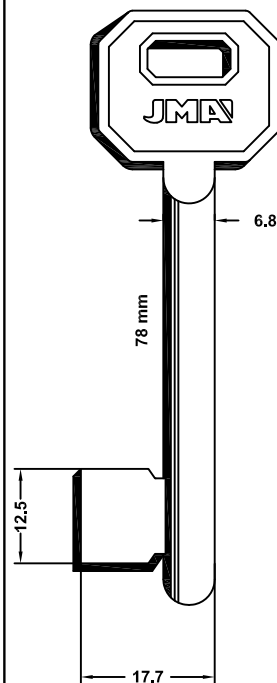
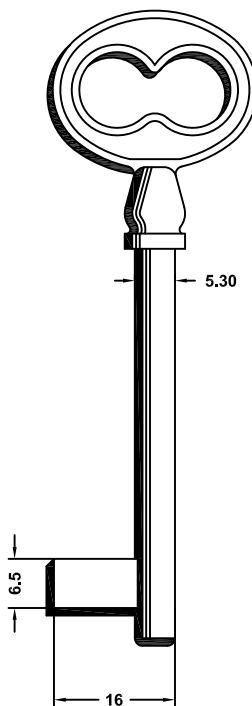
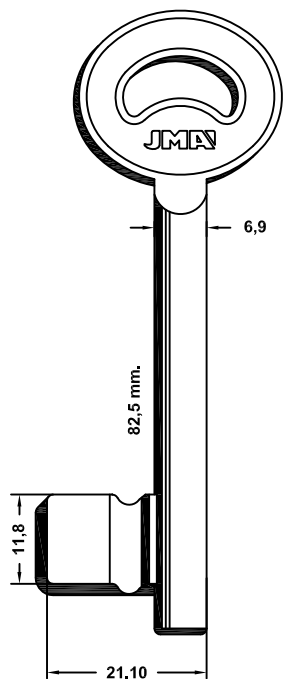

DMR-7-1



DMR-7-3



DMR-7-2



DMR-7-4



DEB-12L



ELZ-2G











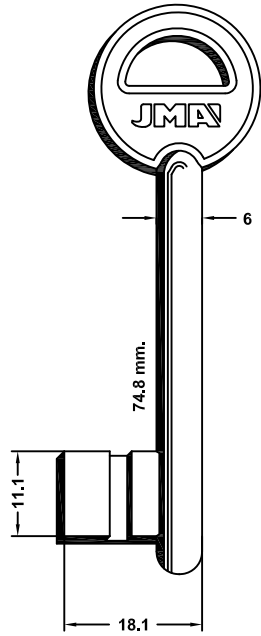
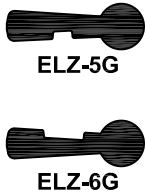
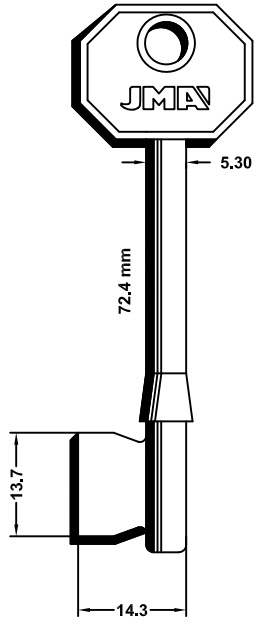

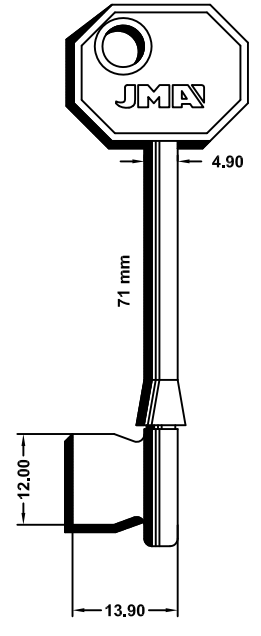

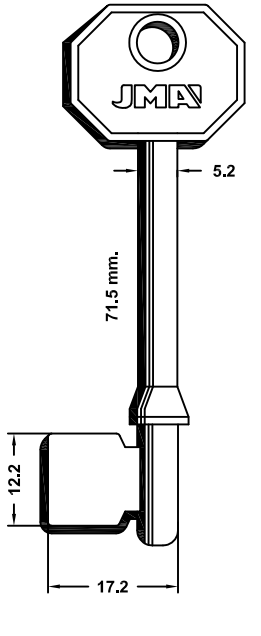

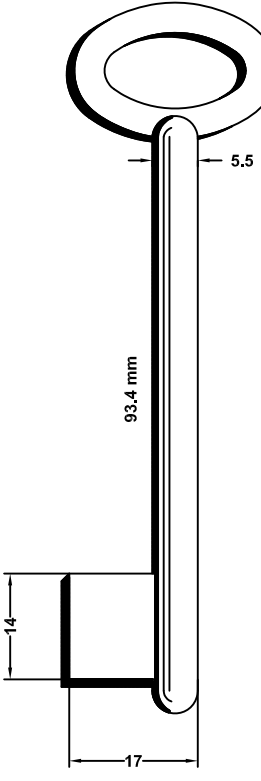
ELZ-3G

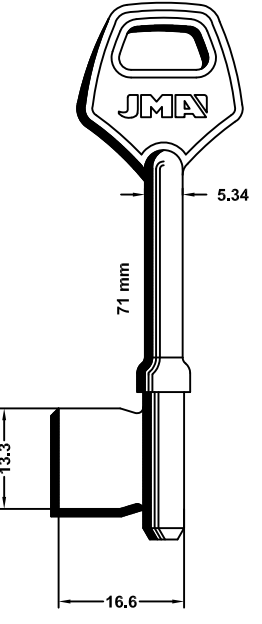

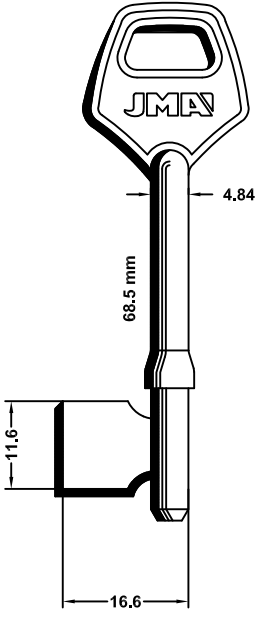
**PARA-FOR:**

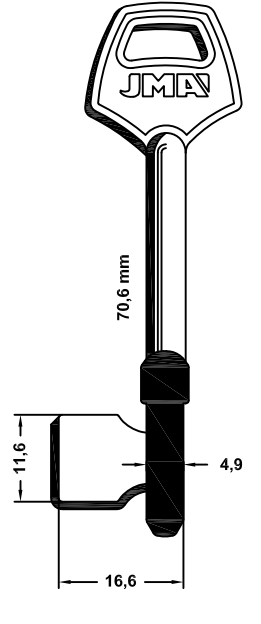
- ELZETT (H)
- ERA (GB)
- ESA (E)
- FAS-YALE (S)

| ELZETT  | ERA   |  |  |
|---|---|--|--|
|  <p>74.8 mm.</p> <p>11.1</p> <p>18.1</p> <p>6</p>  <p>ELZ-5G</p> <p>ELZ-6G</p> |  <p>72.4 mm</p> <p>13.7</p> <p>14.3</p> <p>5.30</p>  <p>ER-1G</p>  |  <p>71 mm</p> <p>12.00</p> <p>13.90</p> <p>4.90</p>  <p>ER-4G</p>    |  <p>71.5 mm.</p> <p>12.2</p> <p>17.2</p> <p>5.2</p>  <p>ER-5G</p>     |
| ESA   | FAS-YALE  |  |  |
|  <p>93.4 mm</p> <p>14</p> <p>17</p> <p>5.5</p>  <p>ES-1G</p>                |  <p>71 mm</p> <p>13.3</p> <p>16.6</p> <p>5.34</p>  <p>FA-1G</p> |  <p>68.5 mm</p> <p>11.6</p> <p>16.6</p> <p>4.84</p>  <p>FA-2G</p> |  <p>70.6 mm</p> <p>11.6</p> <p>16.6</p> <p>4.9</p>  <p>FA-2PPG</p> |



# FAS-YALE

# PARA-FOR:

FAS-YALE (S)

FICHET (F)

GPZ (RUS)

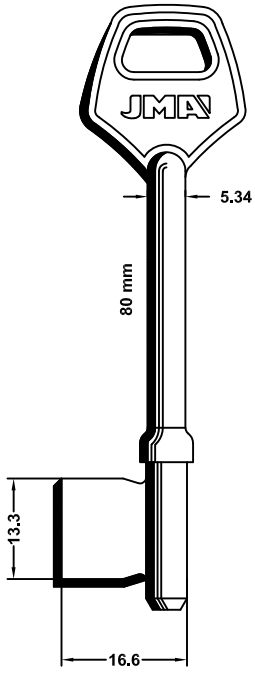

FA-3G

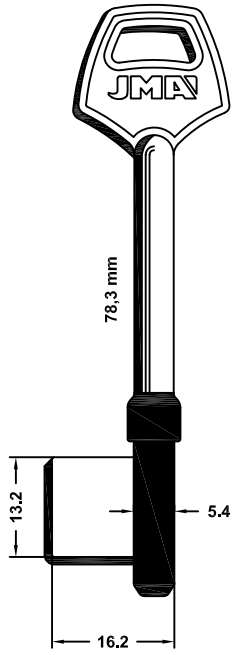

FA-3PPG

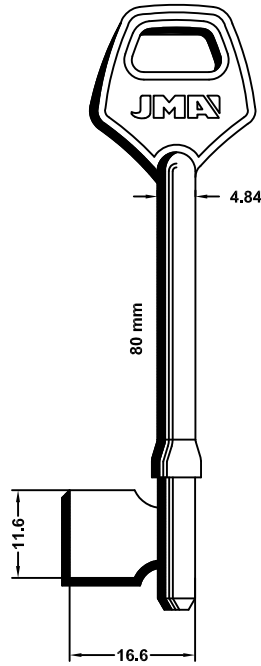

FA-4G

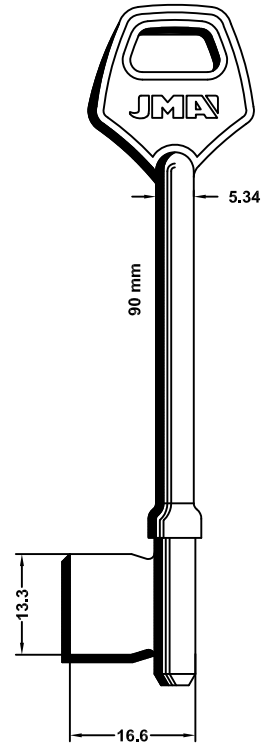

FA-5G

## FAS-YALE

## FICHET

## GPZ

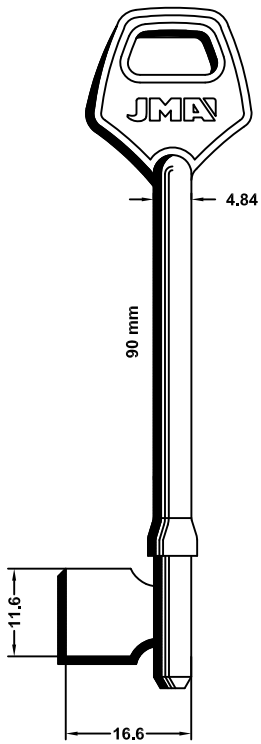

FA-6G

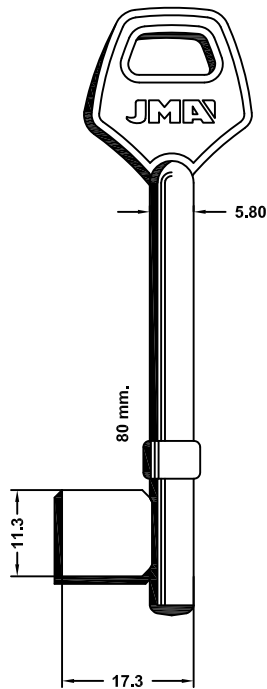

FA-7G

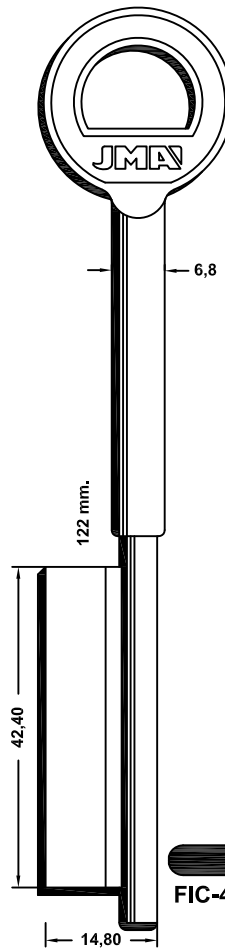

FIC-401G

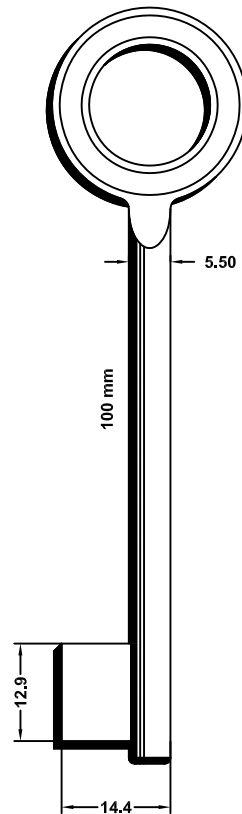









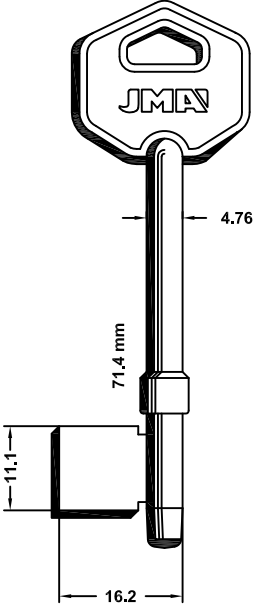

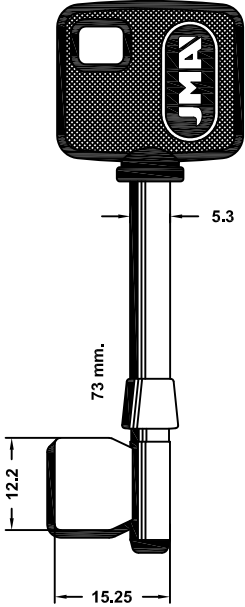

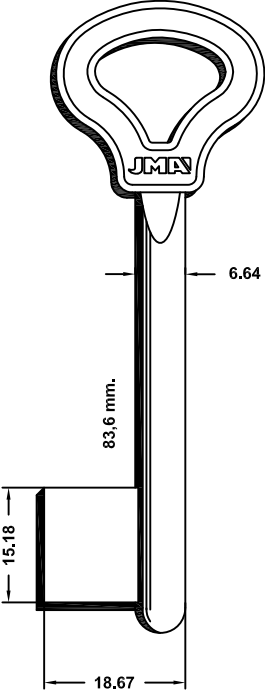

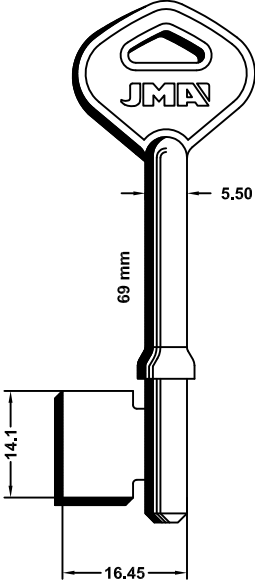

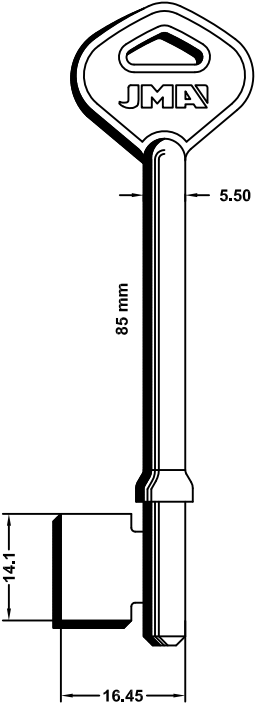
GPZ-1G

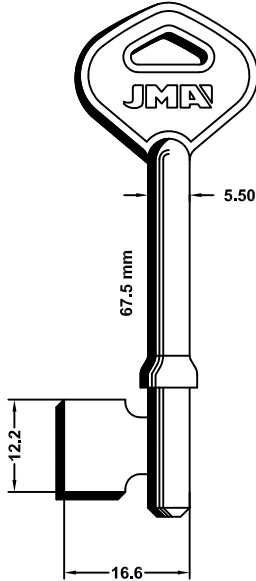

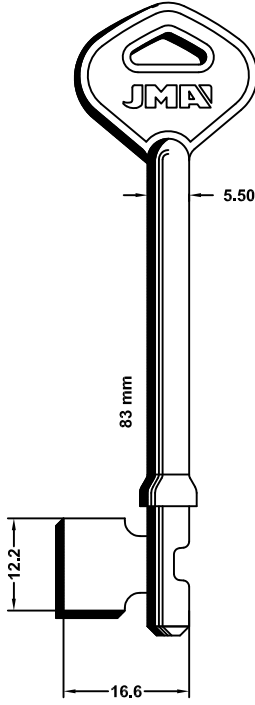
**PARA-FOR:**

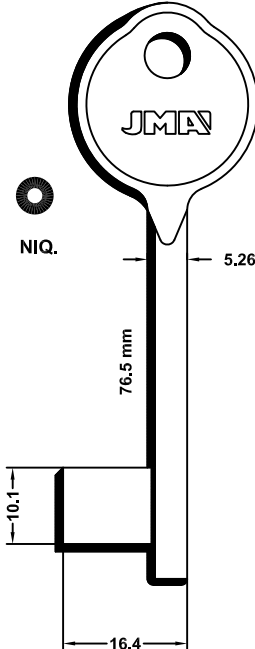
- GUARDIAN (GB)
- HENDERSON (GB)
- LAR (E)
- LÅSBOLAGET (S)
- MCM (E)

| GUARDIAN   | HENDERSON   | LAR  | LÅSBOLAGET  |
|--|---|--|---|
|  <p>4.76<br/>71.4 mm<br/>11.1<br/>16.2</p>  <p><b>GUR-1G</b></p>     |  <p>5.3<br/>73 mm.<br/>12.2<br/>15.25</p>  <p><b>HEN-1G.P</b></p>     |  <p>6.64<br/>83.6 mm.<br/>15.18<br/>18.67</p>  <p><b>LAR-1G</b></p>  |  <p>5.50<br/>69 mm<br/>14.1<br/>16.45</p>  <p><b>LASB-1G</b></p>              |
| LÅSBOLAGET   |   |  | MCM   |
|  <p>5.50<br/>85 mm<br/>14.1<br/>16.45</p>  <p><b>LASB-2G</b></p> |  <p>5.50<br/>67.5 mm<br/>12.2<br/>16.6</p>  <p><b>LASB-3G</b></p> |  <p>5.50<br/>83 mm<br/>12.2<br/>16.6</p>  <p><b>LASB-4G</b></p> |  <p>NIQ.<br/>5.26<br/>76.5 mm<br/>10.1<br/>16.4</p>  <p><b>MCM-1G</b></p> |





| MCM           | MOSKVA        | MP            | ORENGO       |
|---------------|---------------|---------------|--------------|
| <p>MCM-4G</p> | <p>MOK-1G</p> | <p>MPA-1G</p> | <p>OR-3G</p> |

**PARA-FOR:**  
MCM (E)  
MOSKVA (RUS)  
MP (I)  
ORENGO (E)  
OSTMARK (D)  
PASSEPARTOUT

| ORENGO       | OSTMARK       |               | PASSEPARTOUT   |  |   |   |        |      |     |        |      |     |        |    |     |
|--------------|---------------|---------------|--|--|---|---|--------|------|-----|--------|------|-----|--------|----|-----|
| <p>OR-6G</p> | <p>OST-1G</p> | <p>OST-2G</p> | <table border="1"> <thead> <tr> <th></th> <th>A</th> <th>B</th> </tr> </thead> <tbody> <tr> <td>PPT-3G</td> <td>14,5</td> <td>7,6</td> </tr> <tr> <td>PPT-2G</td> <td>16,5</td> <td>7,9</td> </tr> <tr> <td>PPT-1G</td> <td>18</td> <td>7,6</td> </tr> </tbody> </table> <p>PPT-3G<br/> BONAITI-MAVE-OASA-PATENT<br/> PERINO-STIQUAM</p> <p>PPT-2G<br/> AGB-CORNI-MP-OSMET-PATENT<br/> SMET</p> <p>PPT-1G<br/> BONAITI-ISEO-MP</p> |  | A | B | PPT-3G | 14,5 | 7,6 | PPT-2G | 16,5 | 7,9 | PPT-1G | 18 | 7,6 |
|              | A             | B             |  |  |   |   |        |      |     |        |      |     |        |    |     |
| PPT-3G       | 14,5          | 7,6           |  |  |   |   |        |      |     |        |      |     |        |    |     |
| PPT-2G       | 16,5          | 7,9           |  |  |   |   |        |      |     |        |      |     |        |    |     |
| PPT-1G       | 18            | 7,6           |  |  |   |   |        |      |     |        |      |     |        |    |     |



**PARA-FOR:**

- RENAG (N)
- REX (N)
- TESA (E)
- TRIO-VING (N)

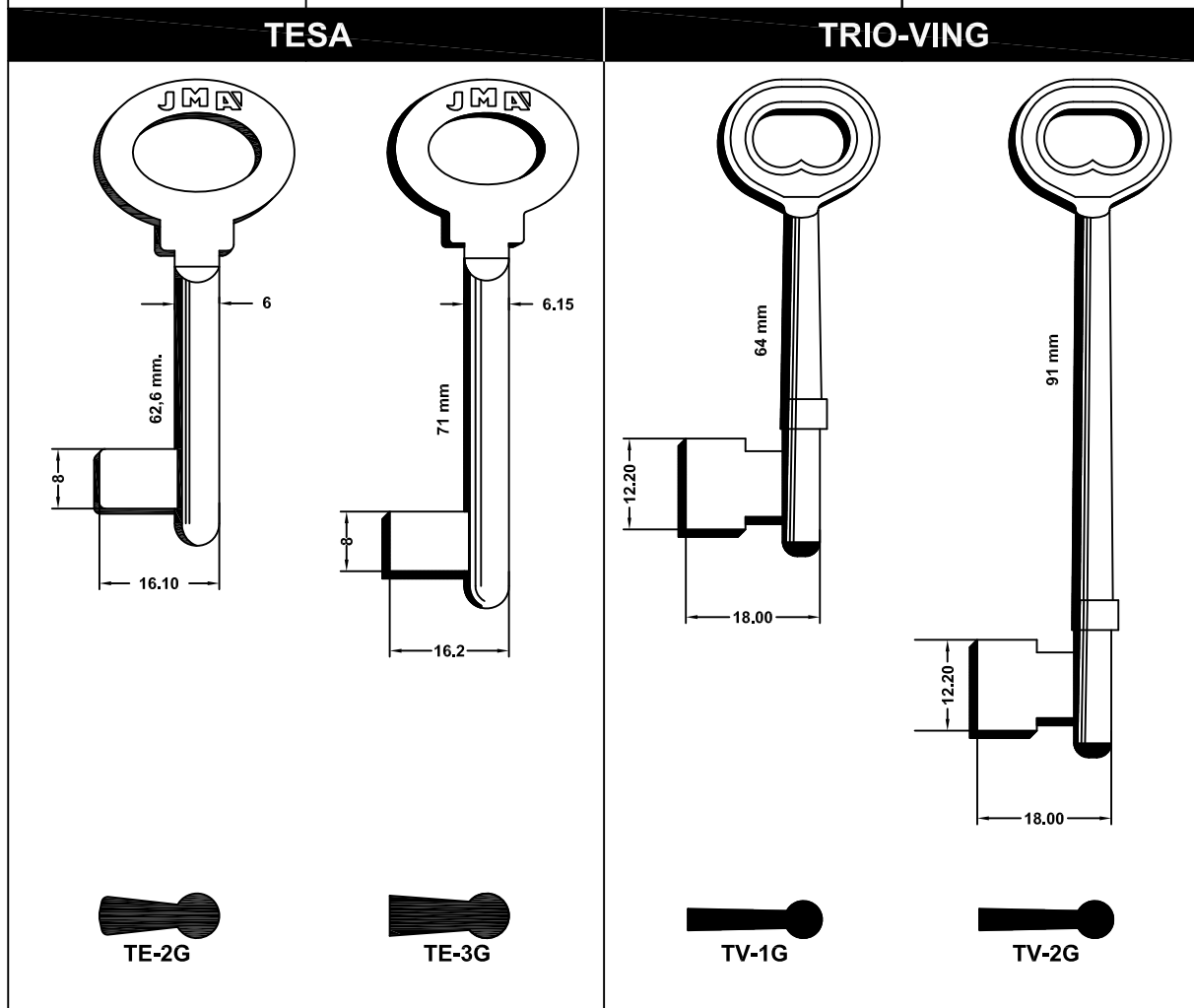
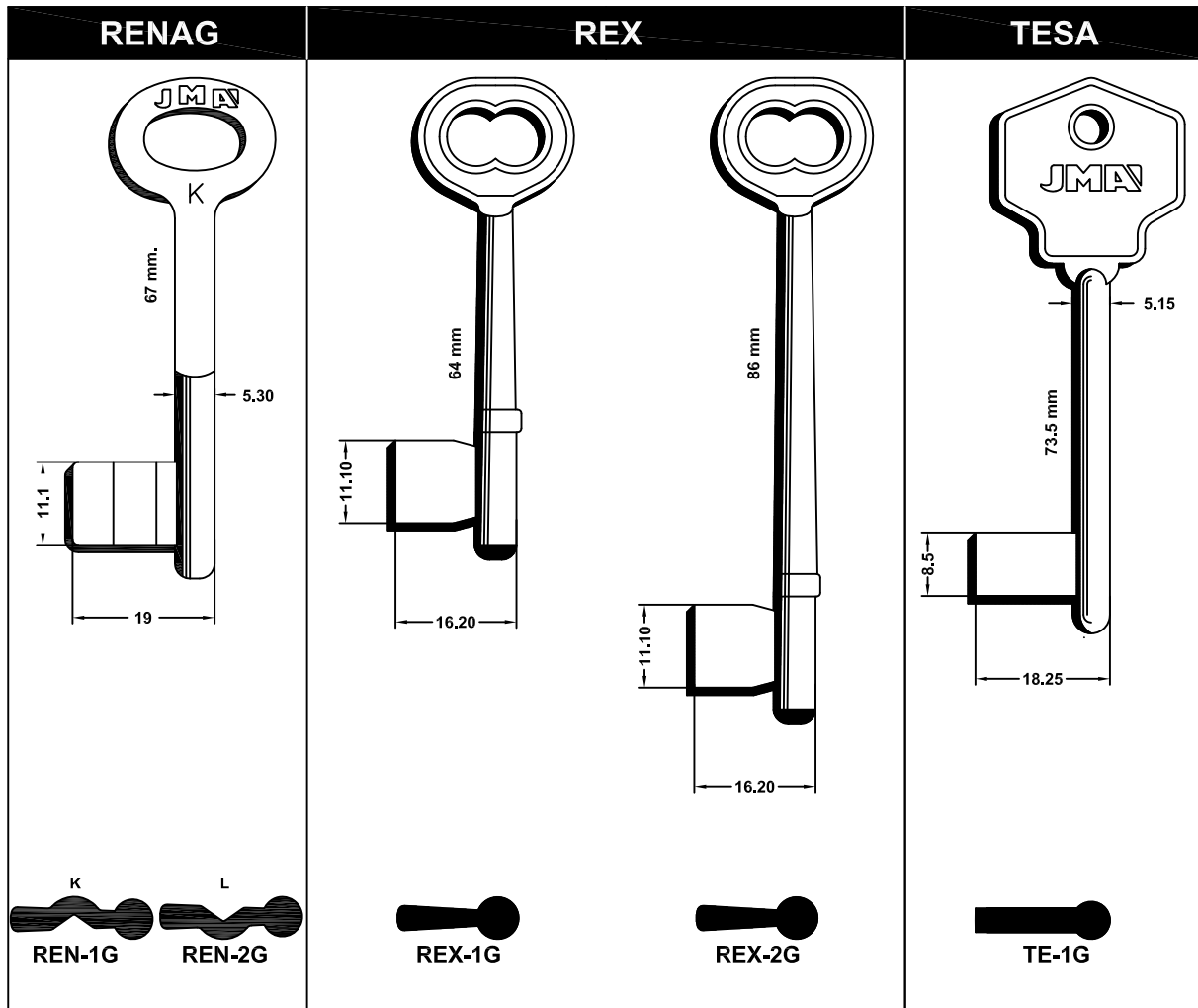

**TRIO-VING**

**PARA-FOR:**

**TRIO-VING (N)**

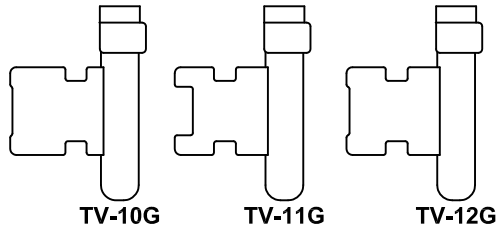
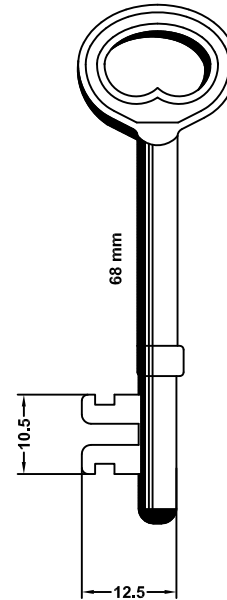
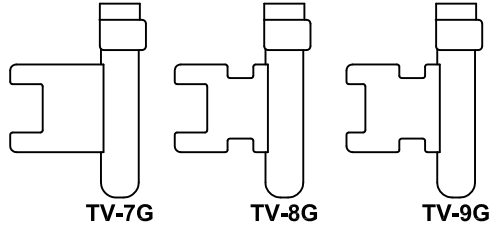
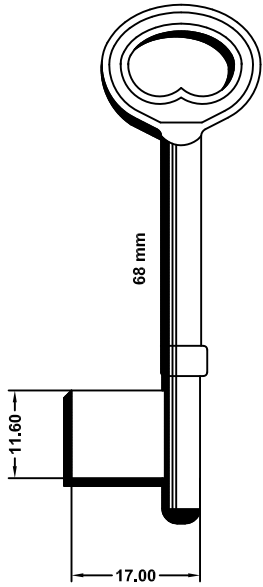

**TV-3G**



**TV-5G**

**TRIO-VING**

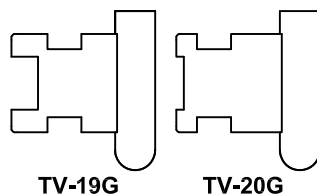
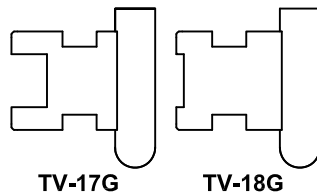
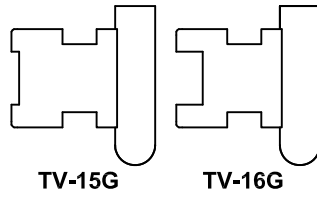
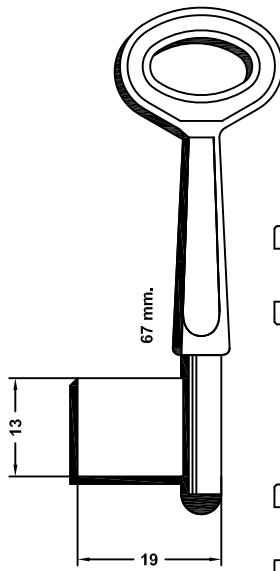
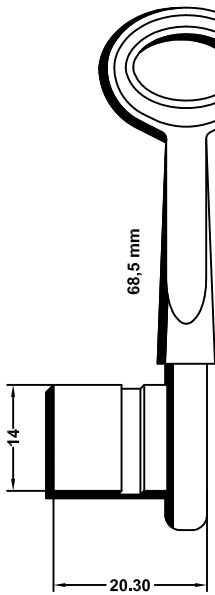

**TV-13G**



**TV-14G**

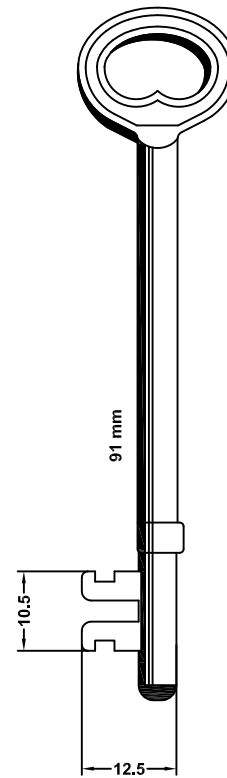

**TV-21G**



**PARA-FOR:**

TRIO-VING (N)

UCEM (E)

UNION (GB)

WMS (GB)

YALE (GB)

| TRIO-VING  |              | UCEM                   |              |
|--|--------------|------------------------|--------------|
| <p>TV-22G TV-23G</p> <p>TV-24G TV-25G</p> <p>TV-26G TV-27G</p> |              | <p>UCEM-1G UCEM-2G</p> |              |
| UCEM   | UNION        | WMS                    | YALE         |
| <p>UCEM-3G</p>   | <p>UN-1G</p> | <p>WM-1G</p>           | <p>YA-5G</p> |



**AKARSAN**

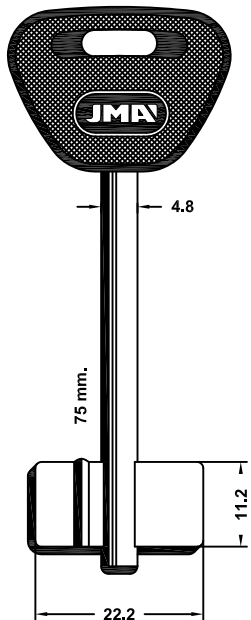

**AKA-1PG**

**ANTONIOLI**

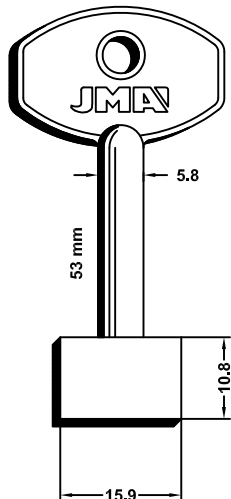

**ANT-1G**

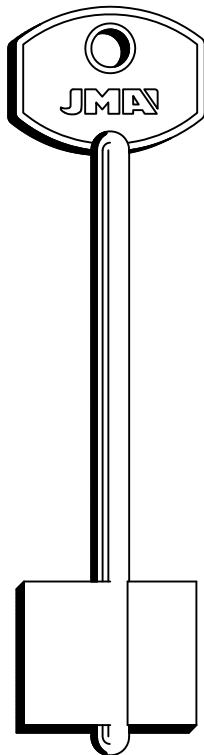

**ANT-2G**

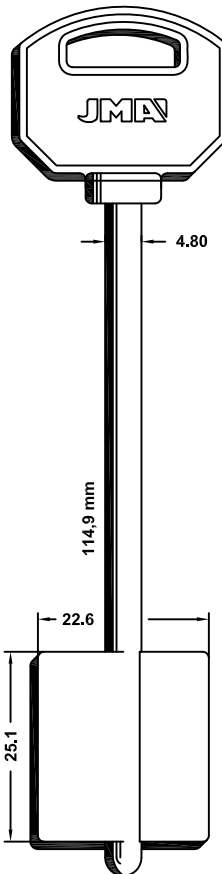

**ANT-3G**

**PARA-FOR:**

AKARSAN (TR)

ANTONIOLI (I)

ASSA (S)

ATRA (I)

**ANTONIOLI**

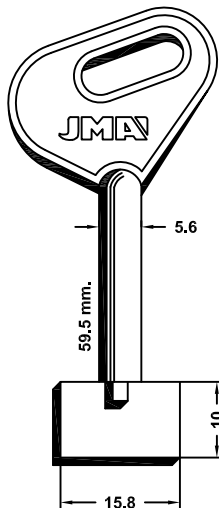

**ANT-4G**

AUNO

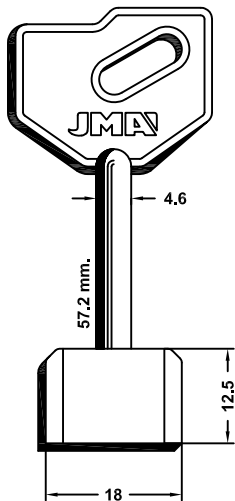

**ANT-5G**

AUNO

**ASSA**

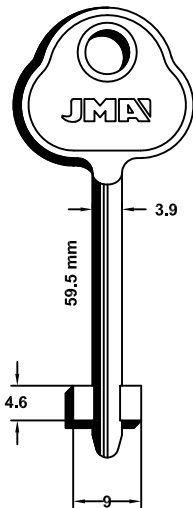

**AS-4G**

**ATRA**

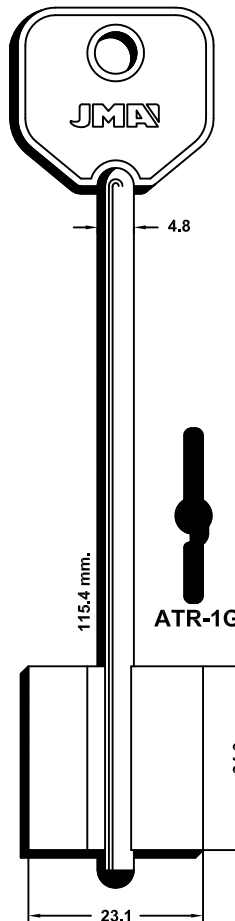

**ATR-1G**



**PARA-FOR:**

ATRA (I)

BETA (I)

**ATRA**

**BETA**

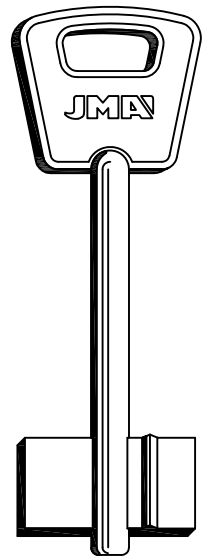
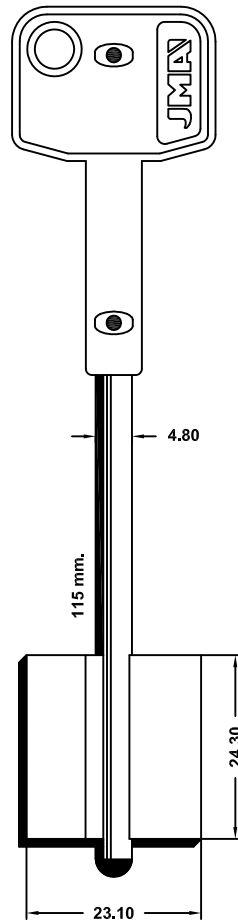
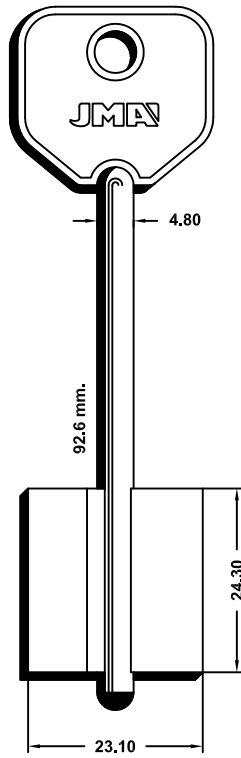

**ATR-2G**



**ATR-2TG**



**BE-1G**

**BETA**

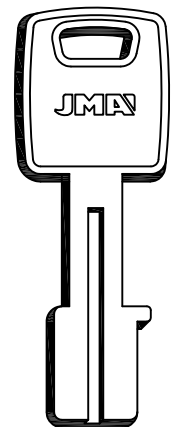
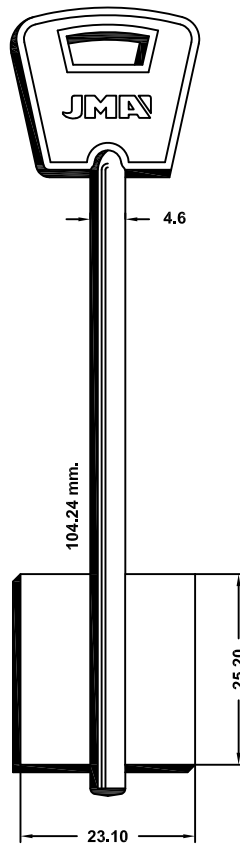
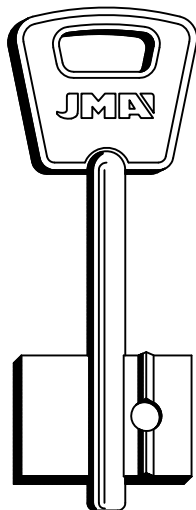

**BE-3G**



**BE-4G**



**BE-5G**



**BE-6G**



**BE-7G**



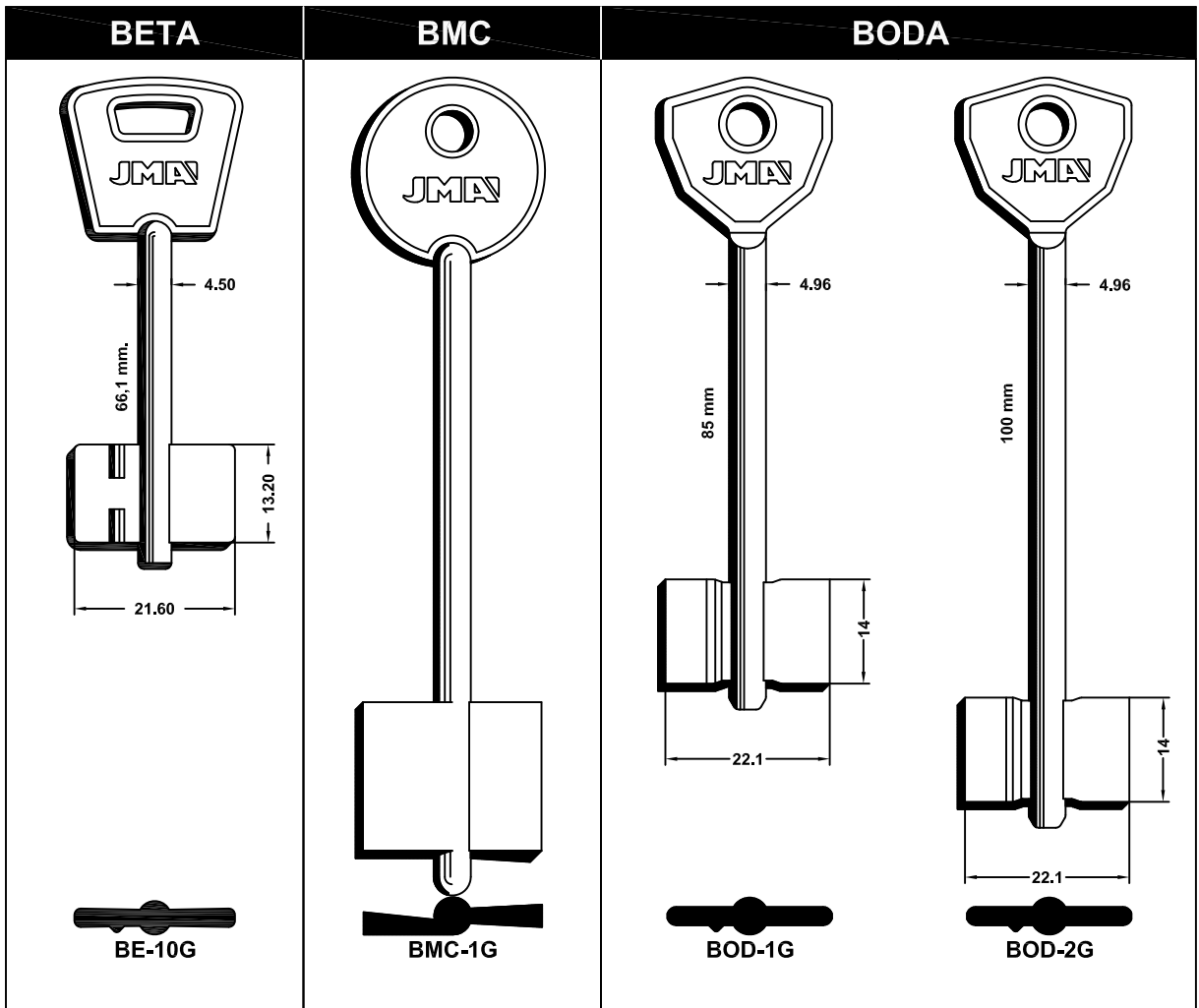

**PARA-FOR:**

- BETA (I)
- BMC (I)
- BODA (SF)
- BOGATIR (RUS)
- BOXAFE (I)

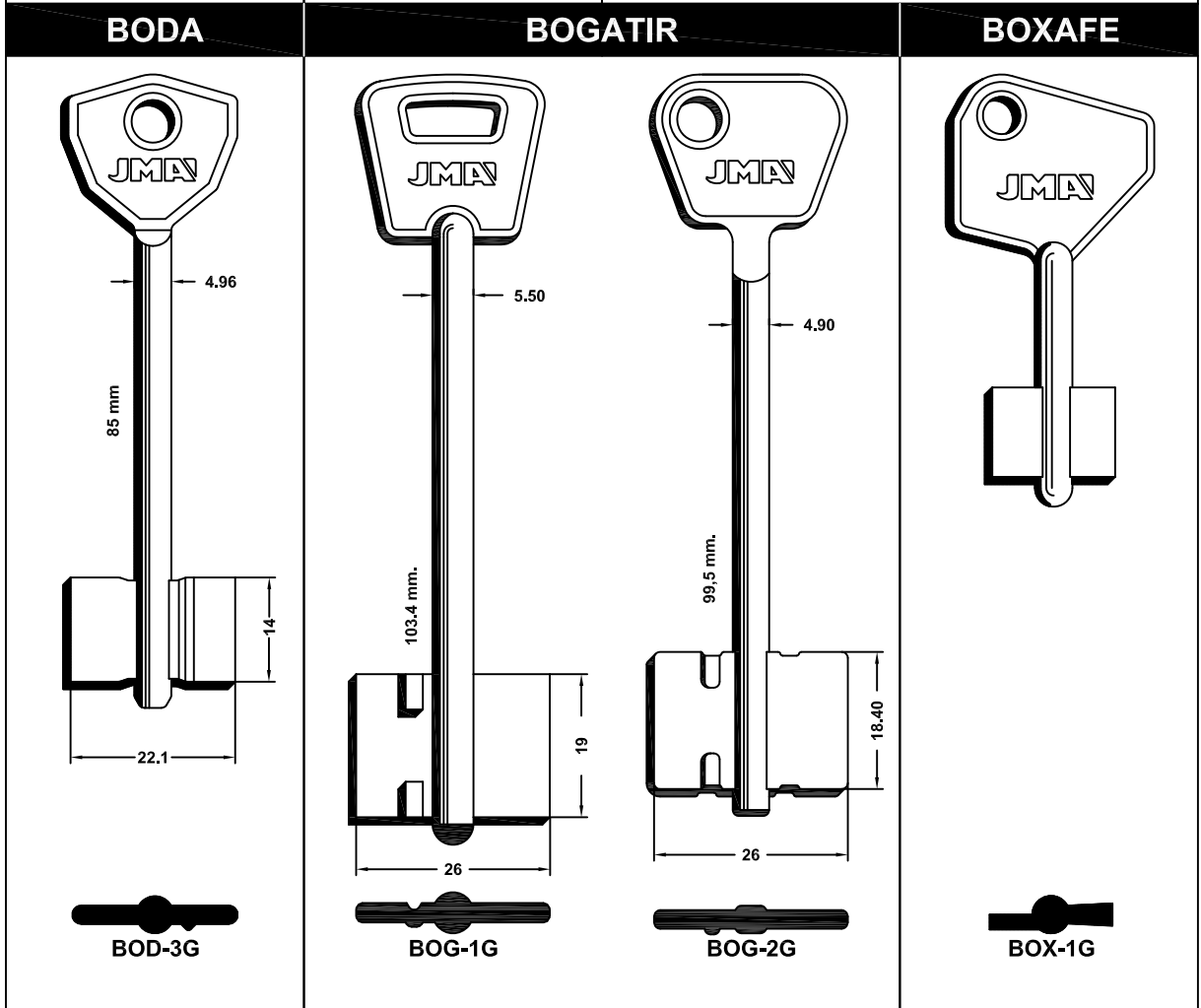

**PARA-FOR:**

CAF (I)

CERUTTI (I)

**CAF**

**CERUTTI**

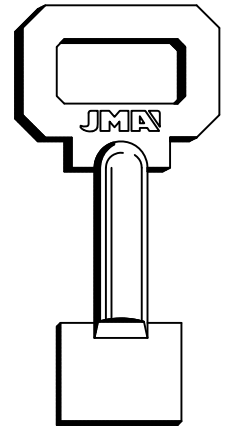
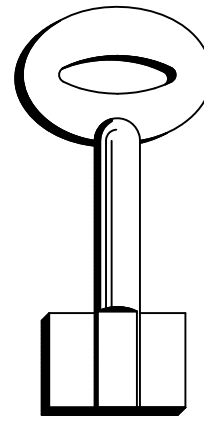
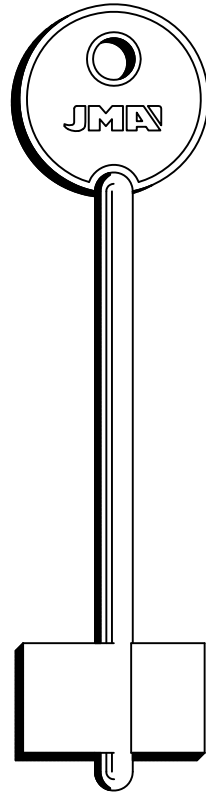
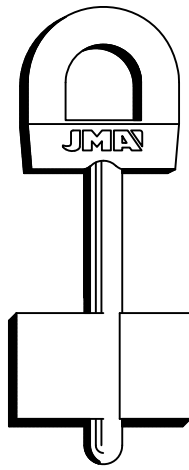

CAF-1G



CAF-2G



CRT-1G



CRT-2G

**CERUTTI**

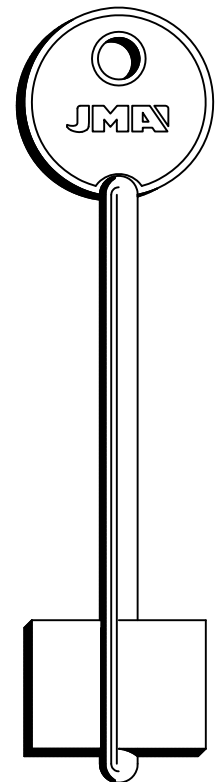
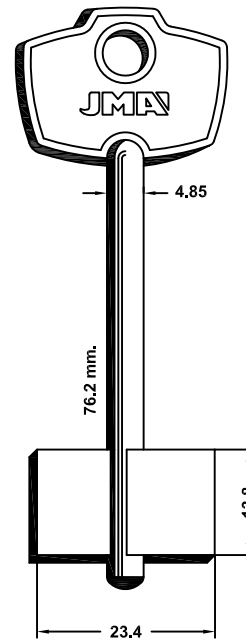
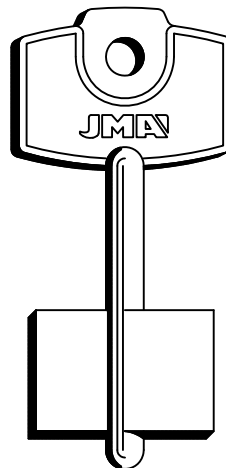
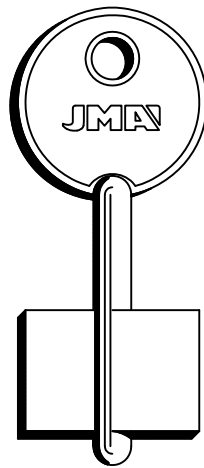

CRT-3G



CRT-4G



CRT-7G



CRT-8G





# CERUTTI

PARA-FOR:

CERUTTI (I)

CHUBB (GB)

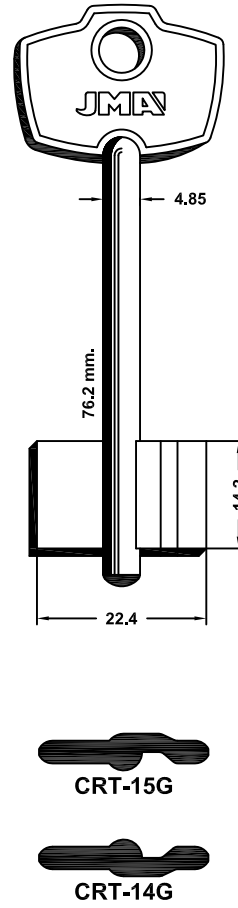
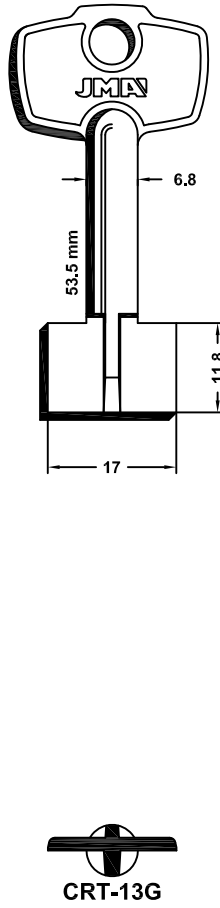
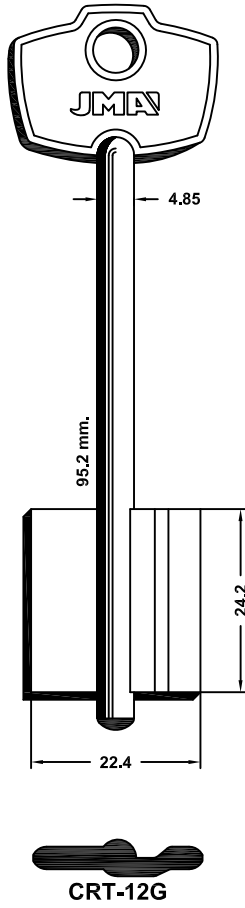
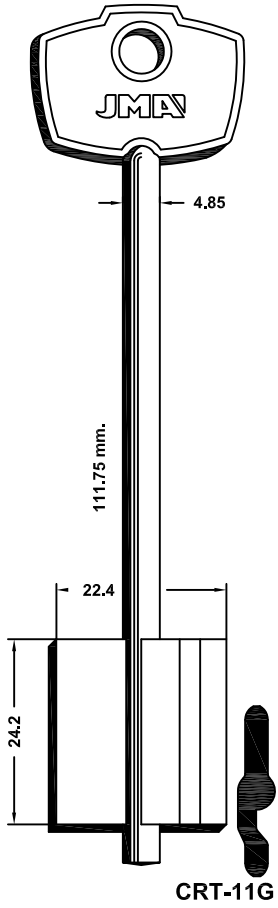

# CERUTTI

# CHUBB

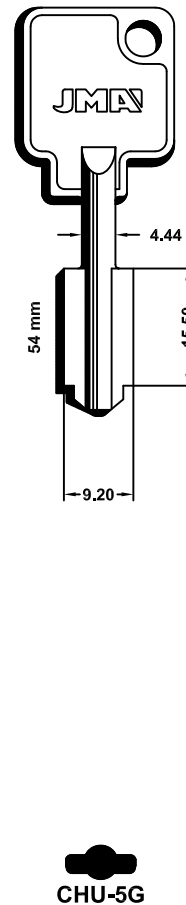
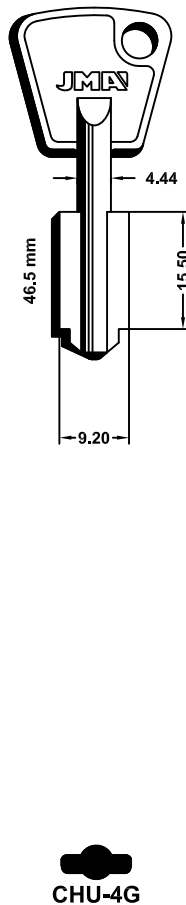
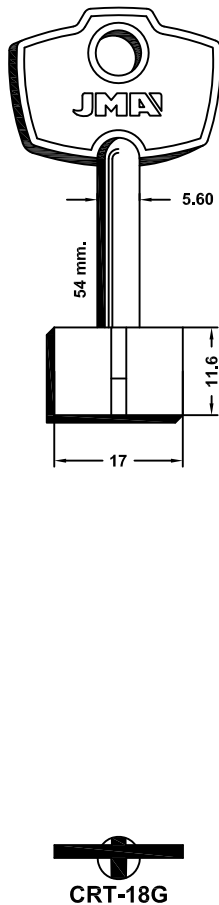
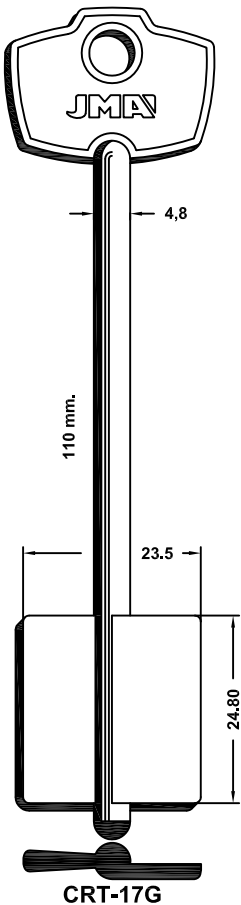

PARA-FOR:

CISA (I)

CISA

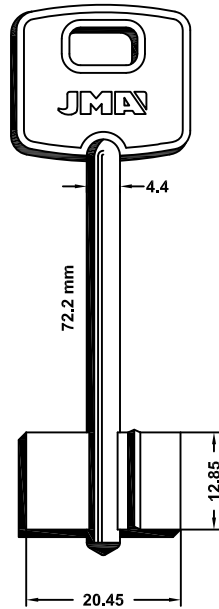

CI-1G



CI-2G

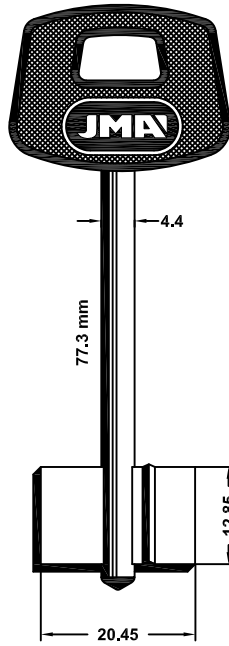

CI-1PG

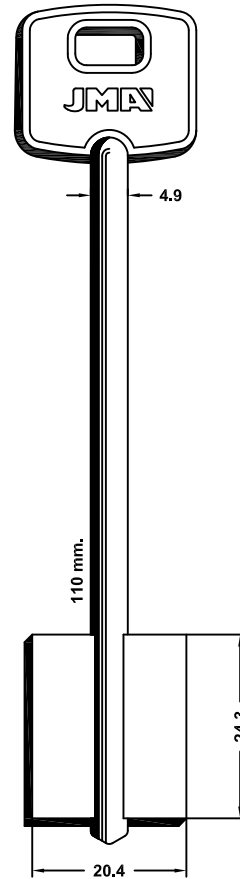

CI-3G



CI-4G

CISA

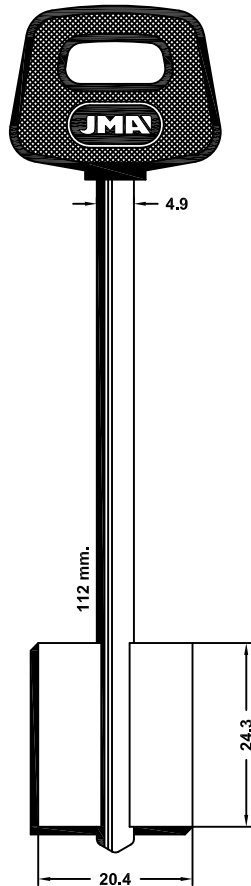

CI-3PG

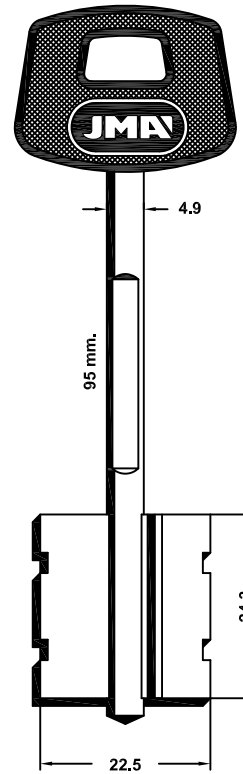

CI-5PG

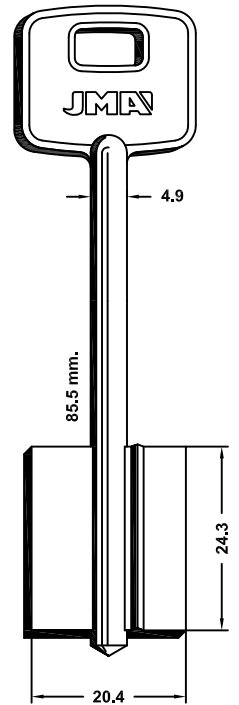

CI-6G



CI-10G



**CISA**

**PARA-FOR:**

CISA (I)

CLASS (RUS)

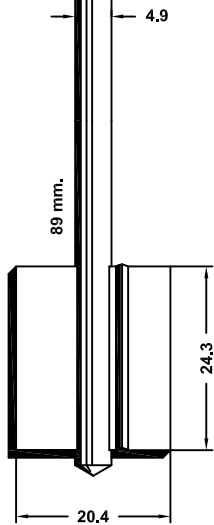

CI-6PG

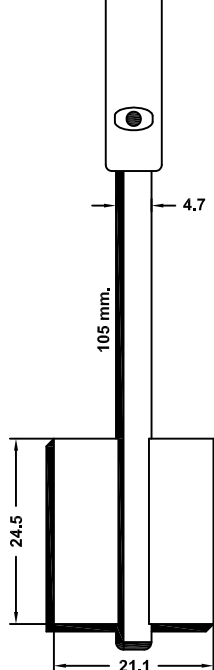
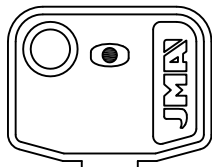

CI-7TG



CI-12TG

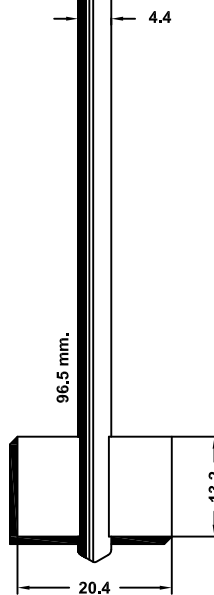
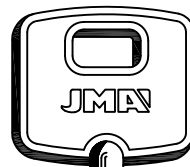

CI-8G

**CISA**

**CLASS**

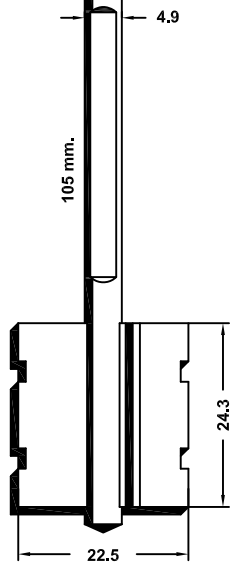

CI-9PG

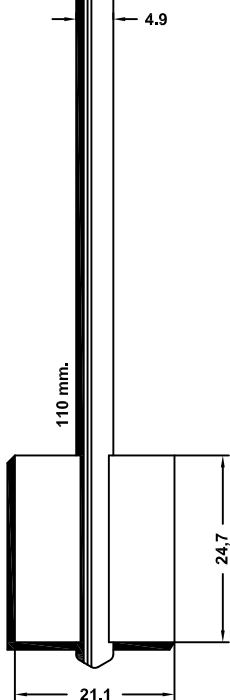
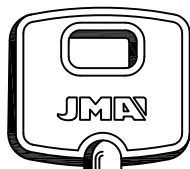

CI-13G



CI-14G

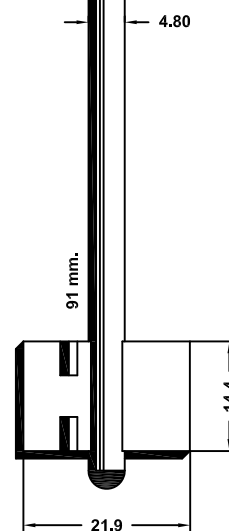
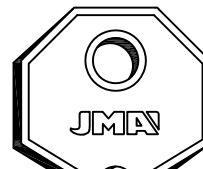

CLA-3G



**PARA-FOR:**

CORNI (I)

CR (I)

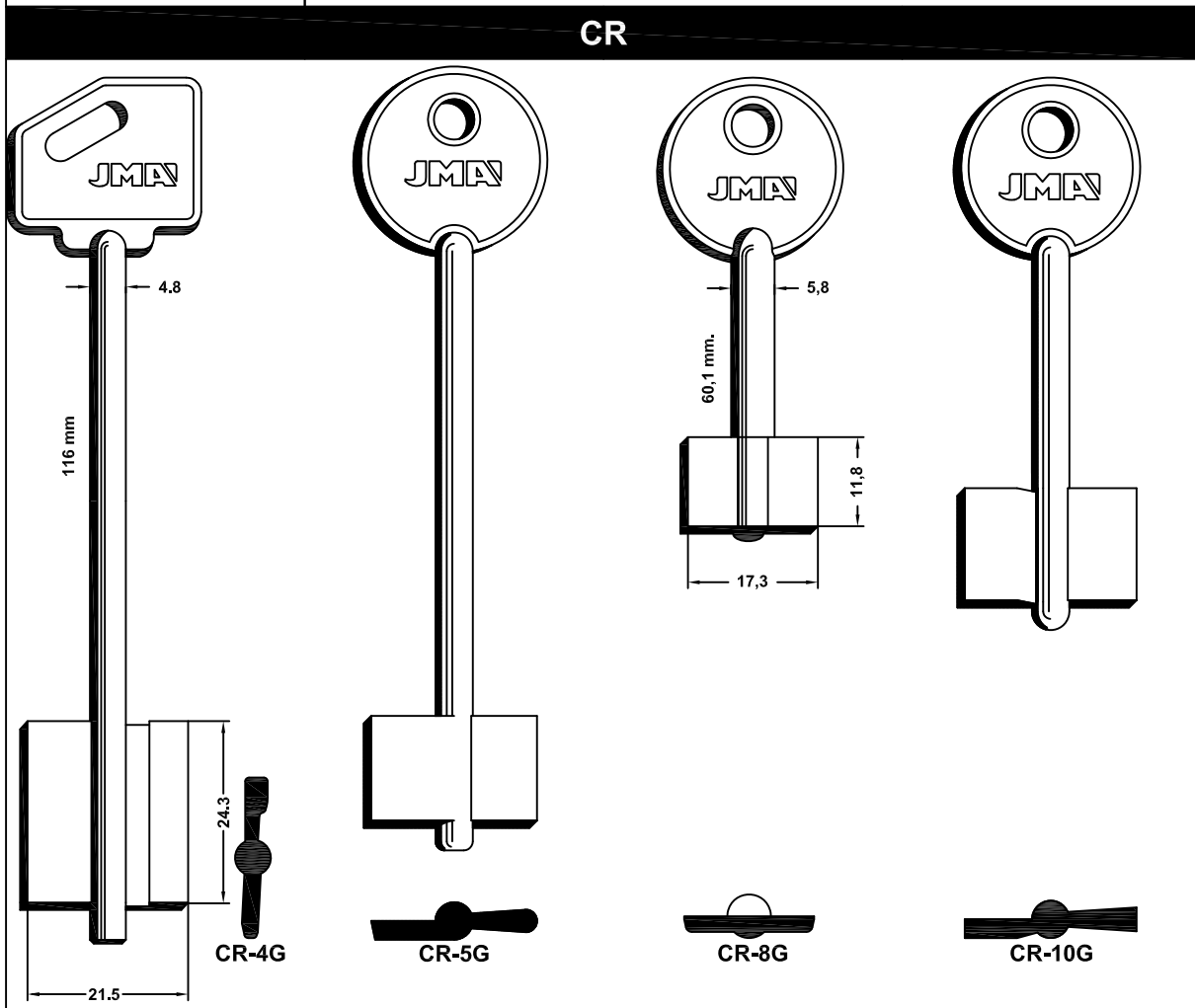
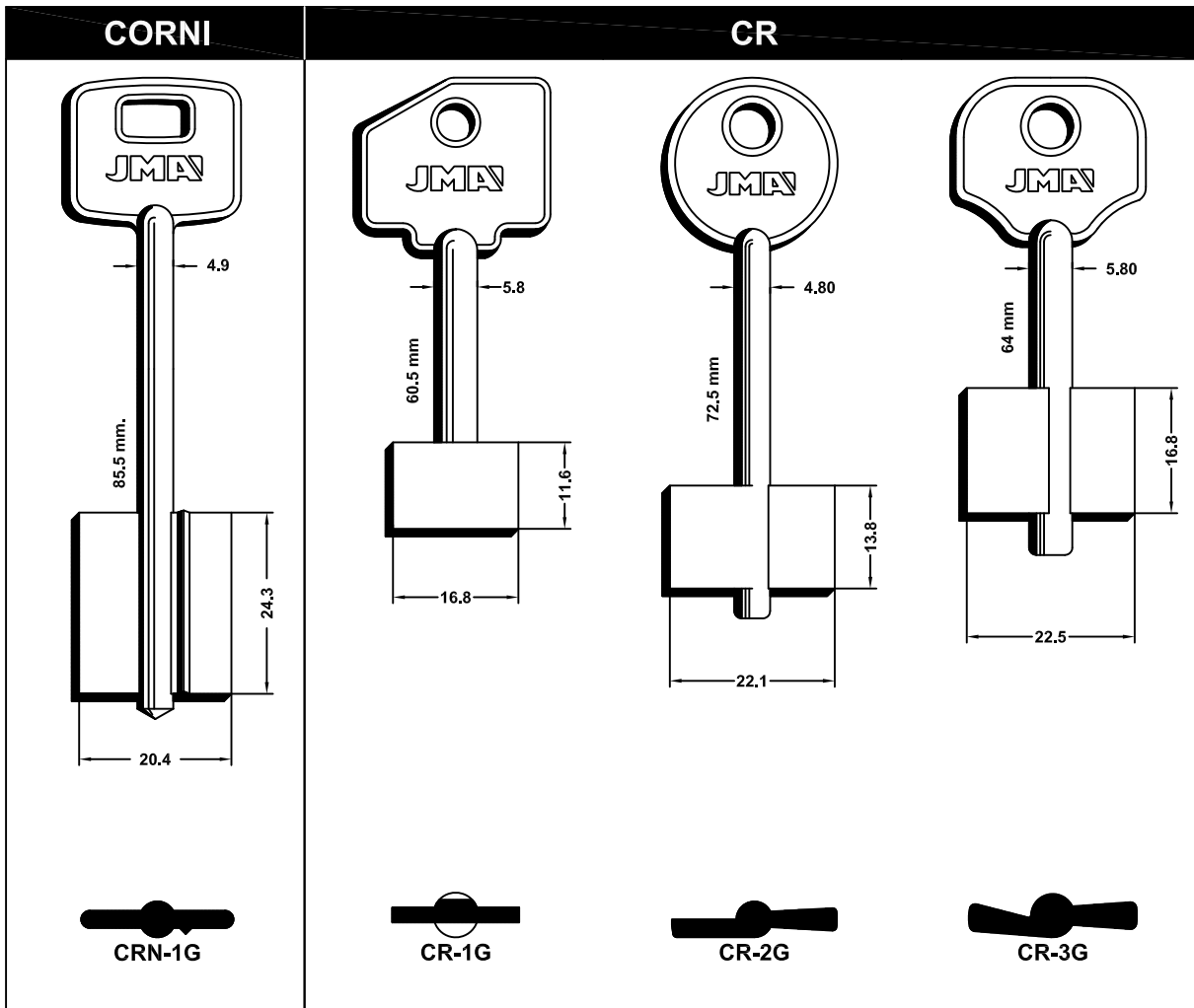

CR

PARA-FOR:

CR (I)

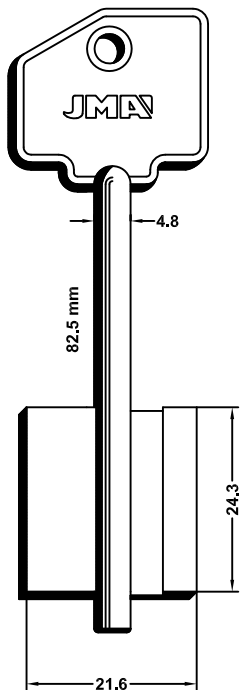

CR-11G

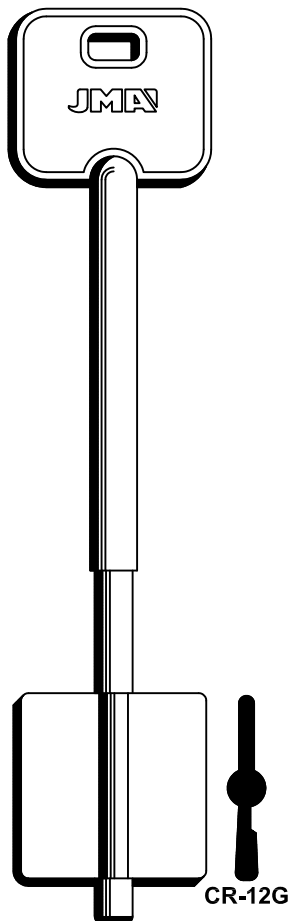

CR-12G

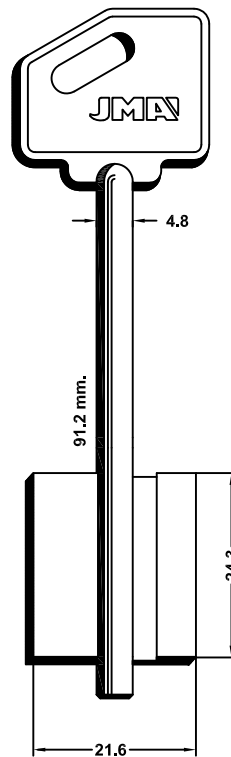

CR-14G

CR

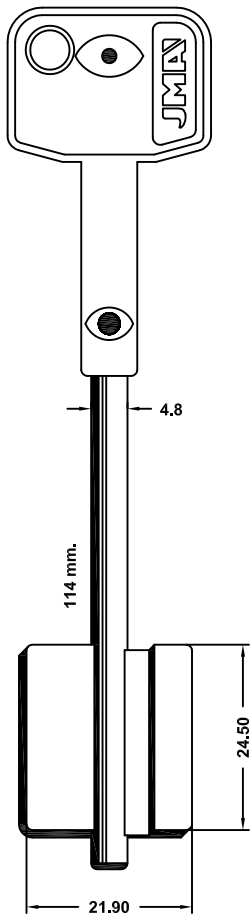

CR-17TG

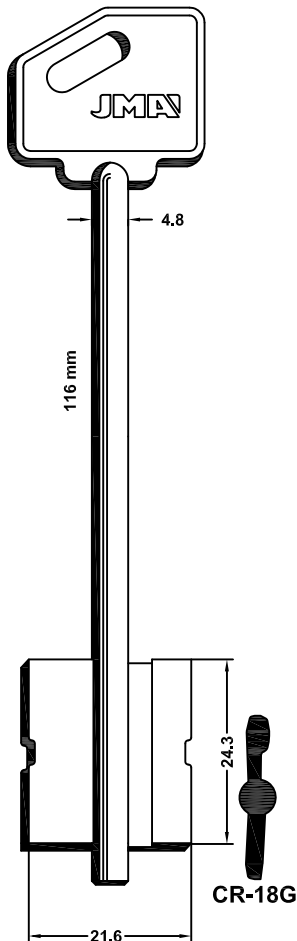

CR-18G

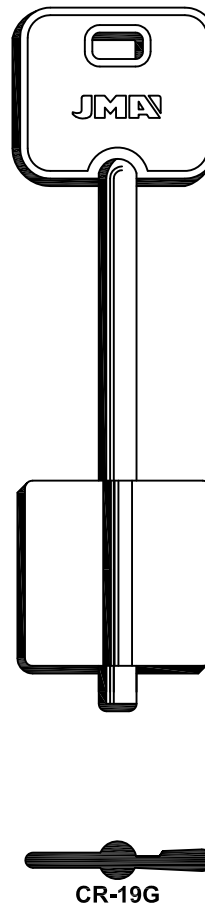

CR-19G



**PARA-FOR:**  
 DEKABA (BG)  
 DVERNIAK (RUS)

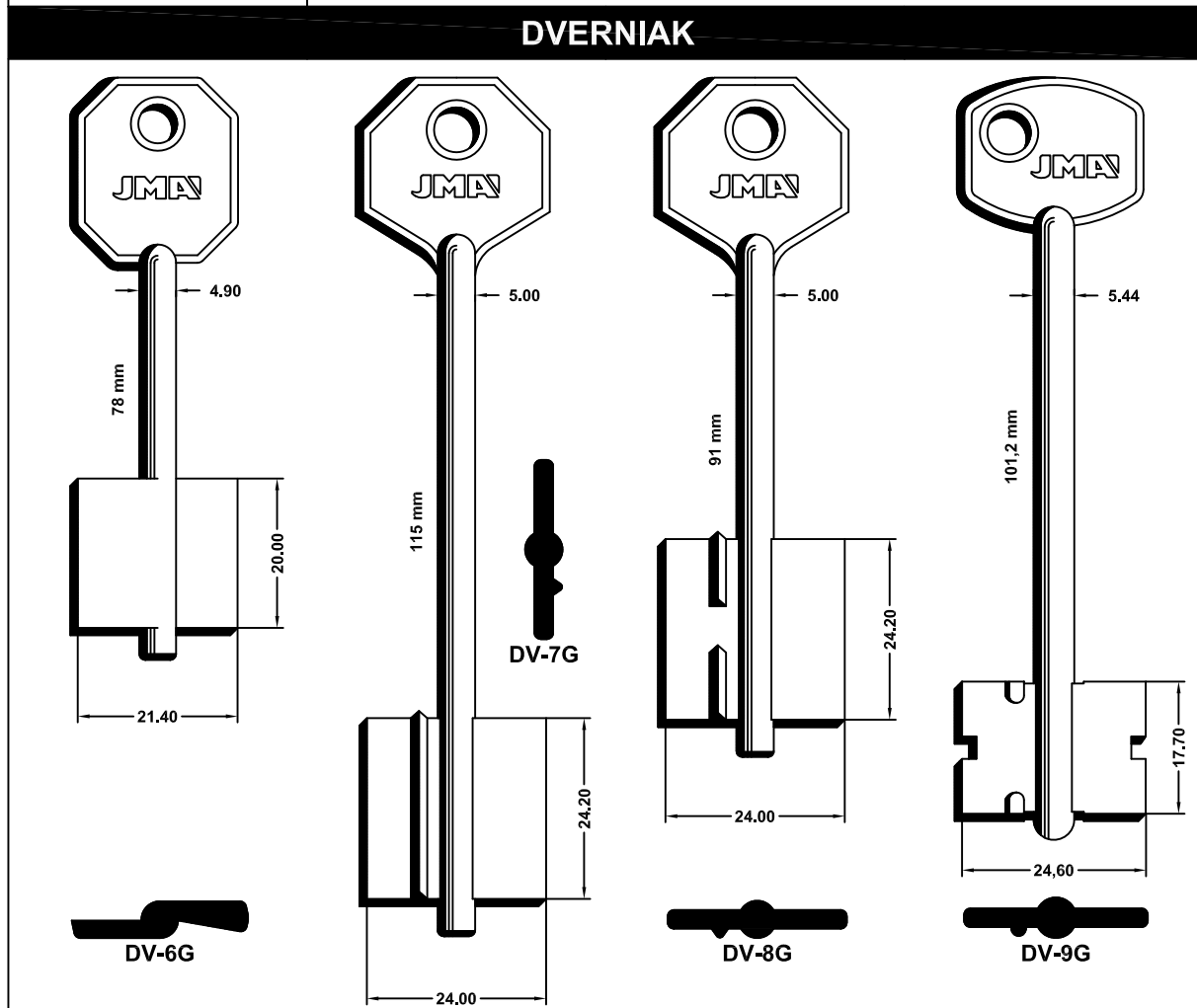
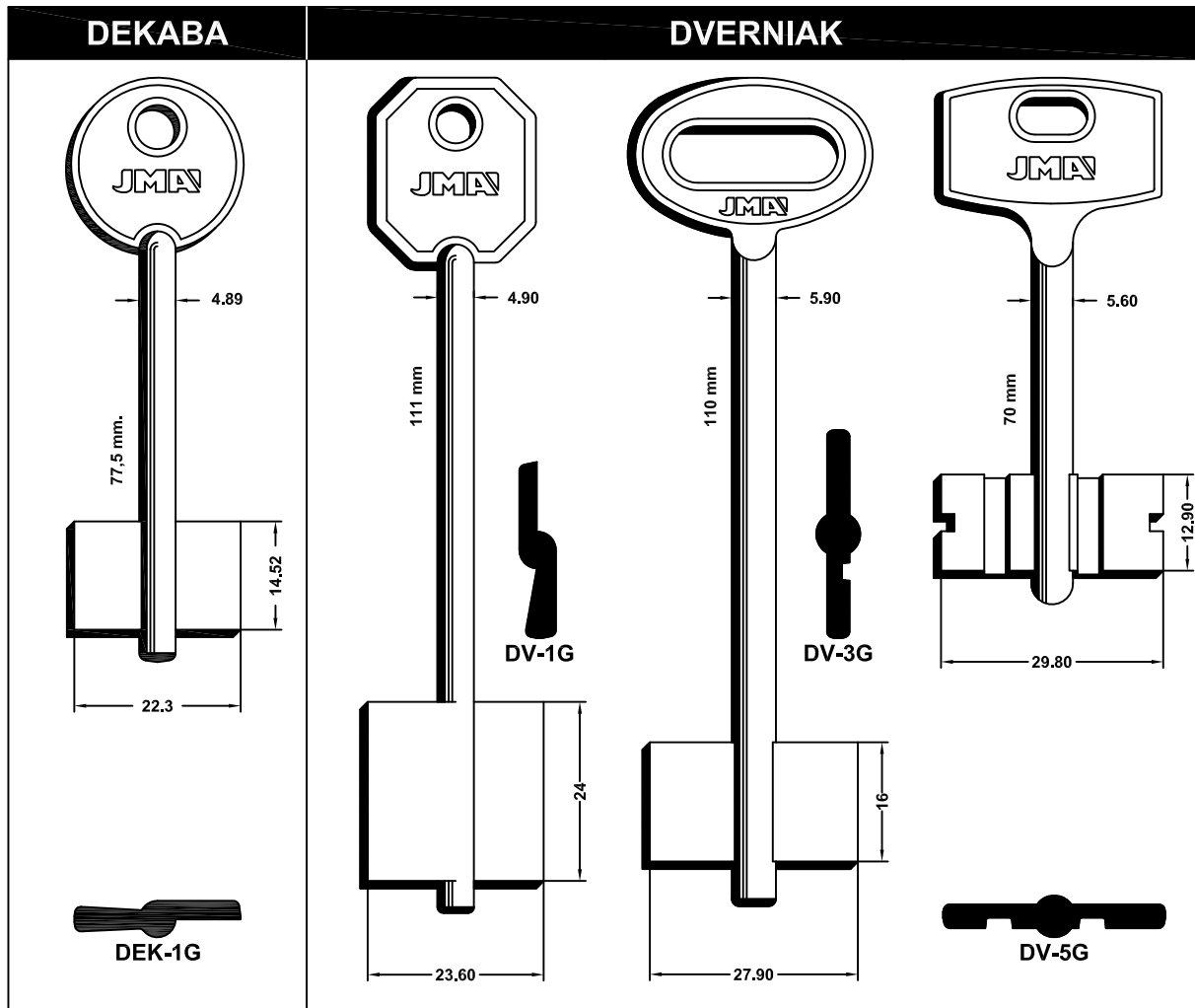

# DVERNIAK

**PARA-FOR:**  
 DVERNIAK (RUS)  
 ELBOR (RUS)

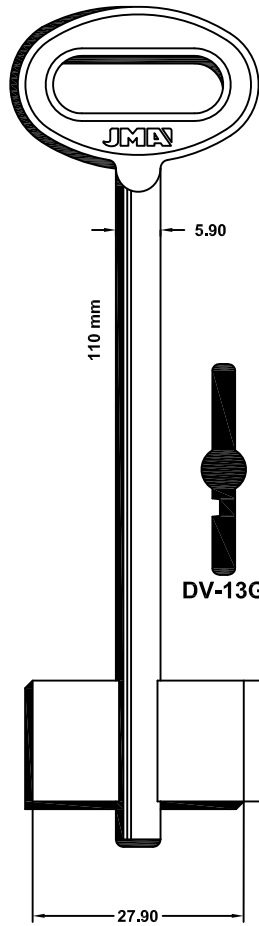
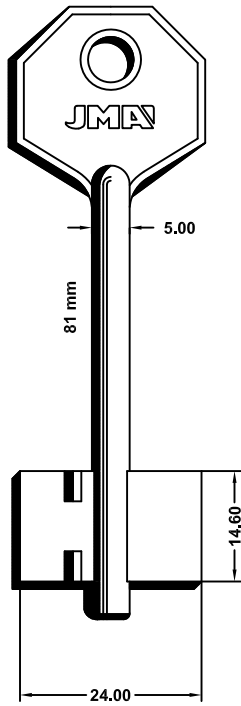
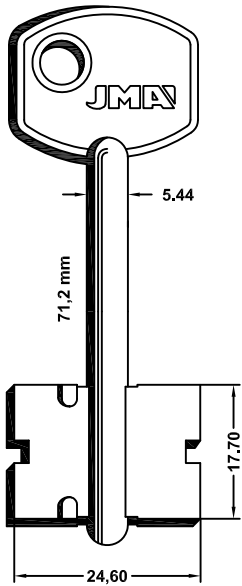

**DV-13G**

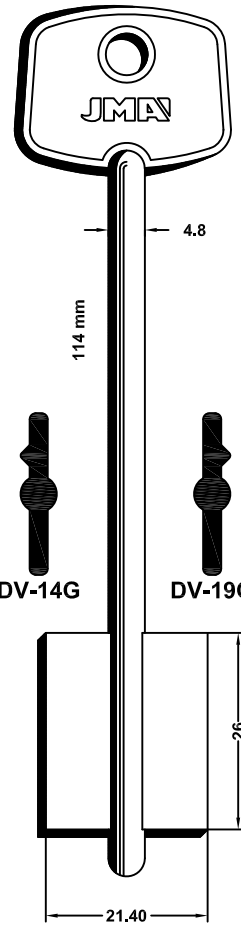

**DV-14G**

**DV-19G**

# DVERNIAK

# ELBOR

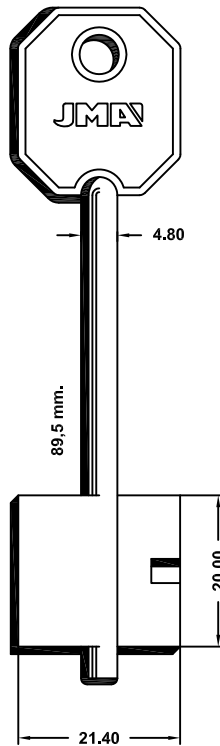
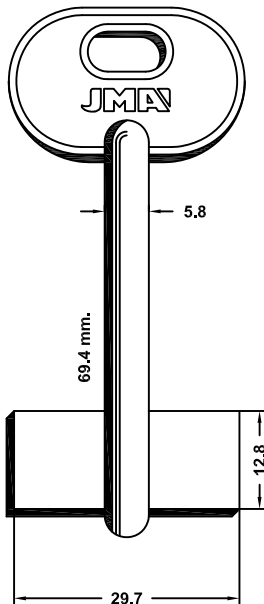
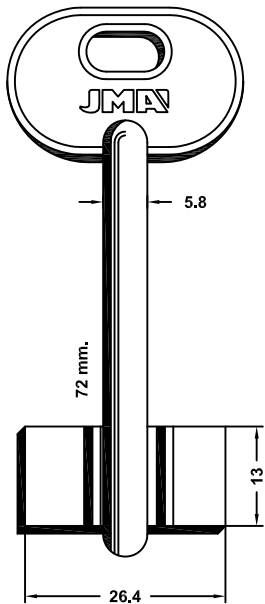

**DV-18G**

METTEM

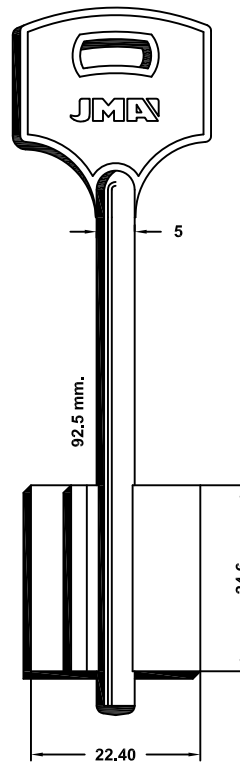

**PARA-FOR:**

ELZETT (H)  
 EREVAN (RUS)  
 ESETY (I)

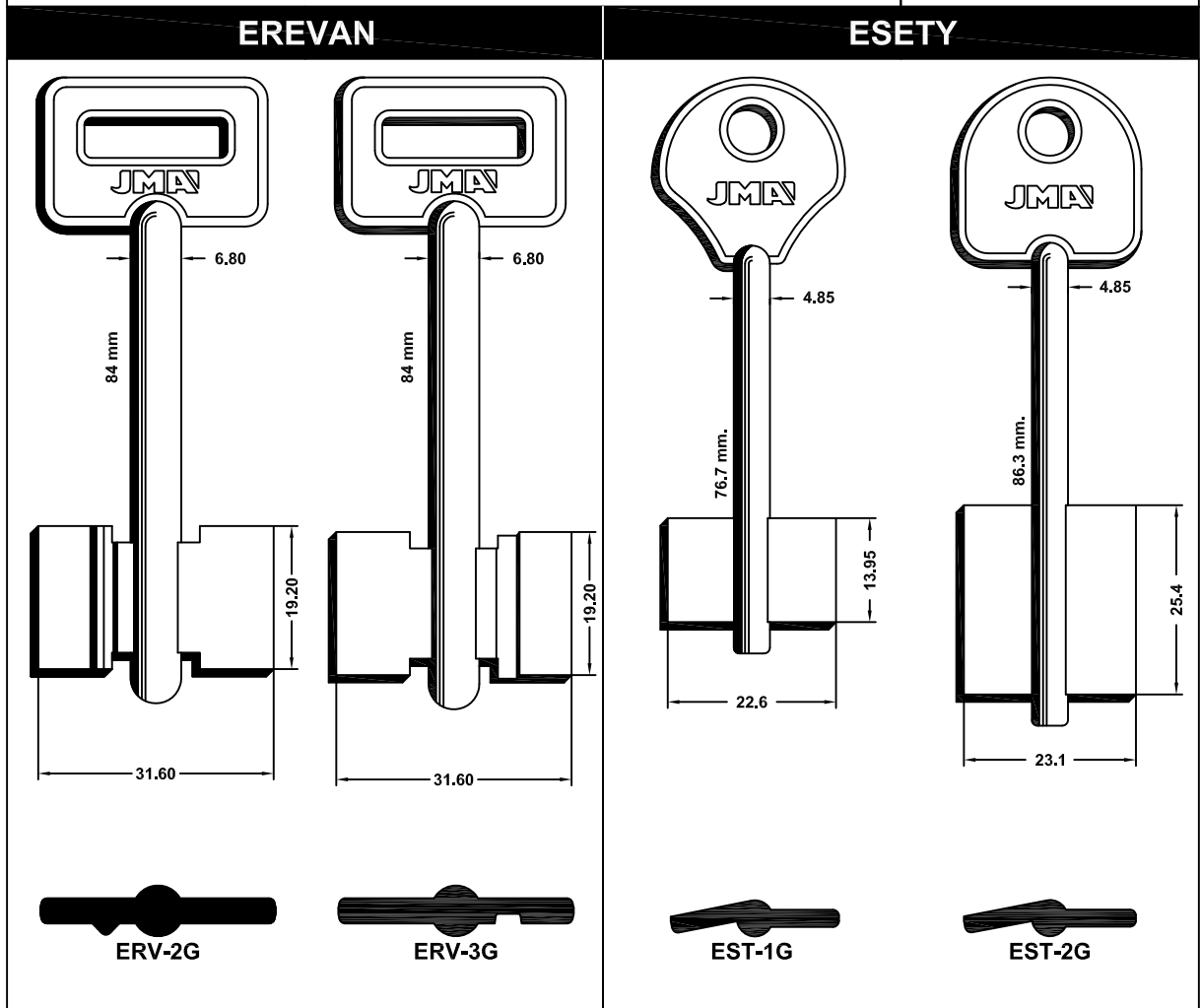
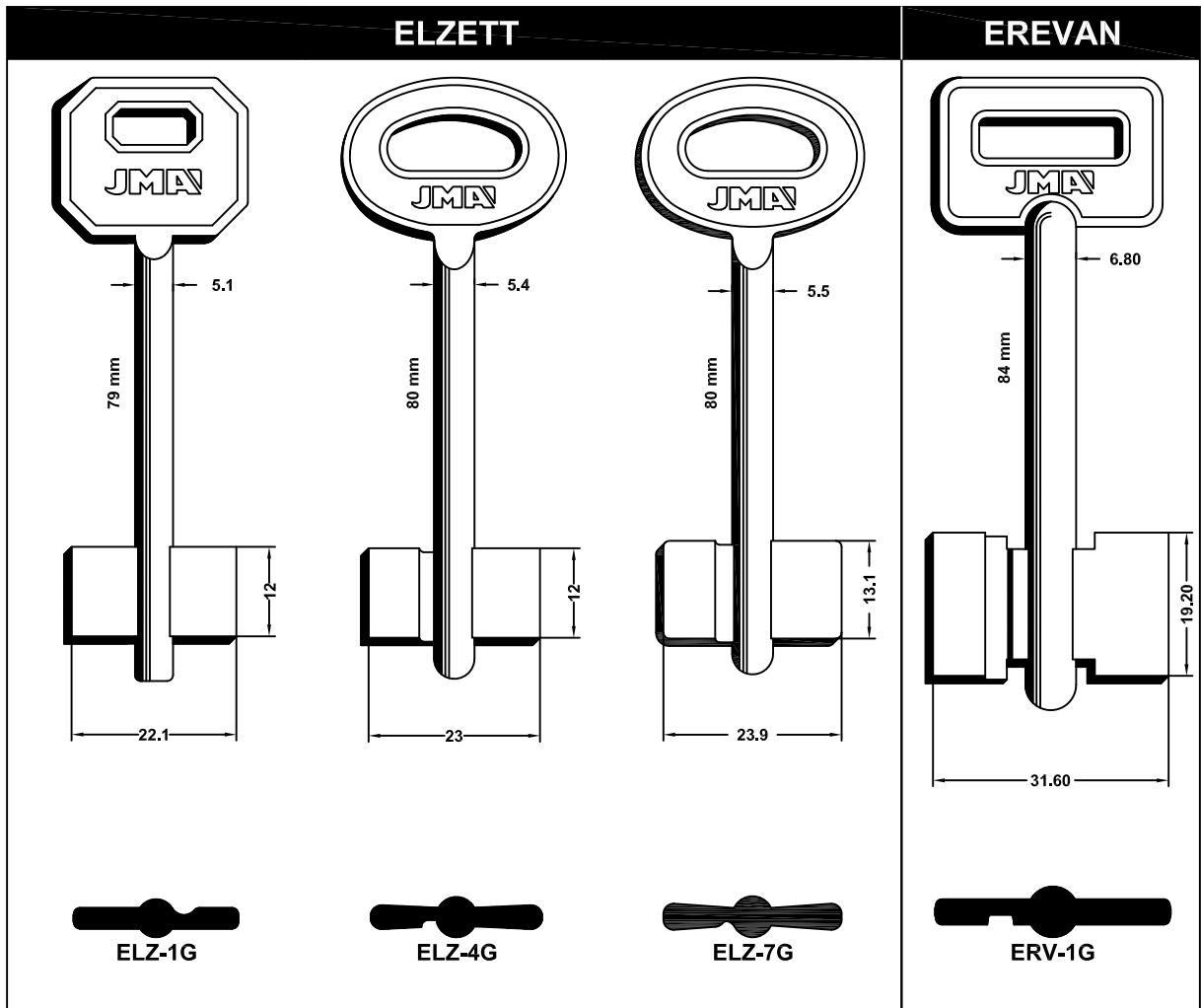



**ESETY**

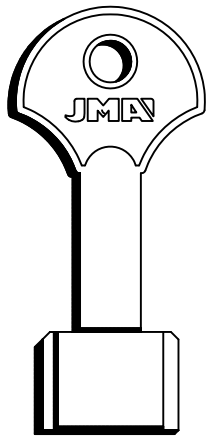

**EST-3G**

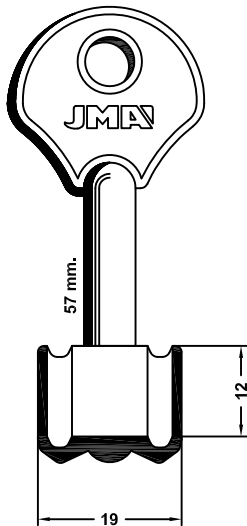

**EST-4G**

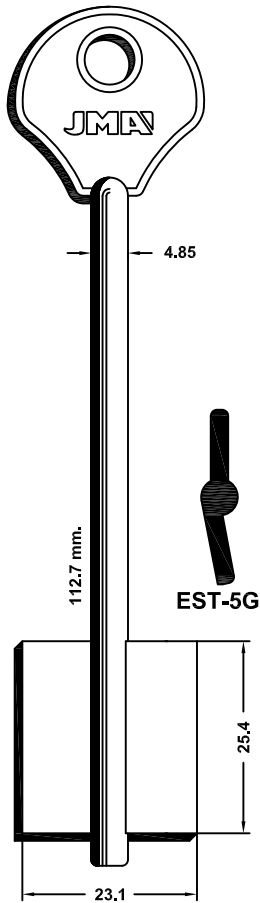

**EST-5G**

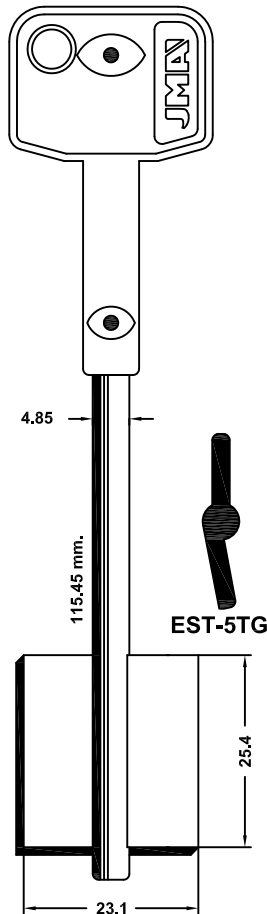

**EST-5TG**

**PARA-FOR:**

ESETY (I)

EUROTEMPLE (I)

**ESETY**

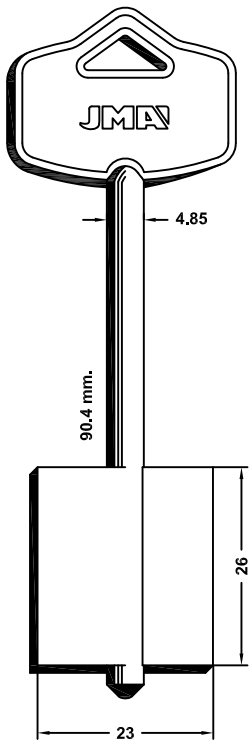

**EST-6G**

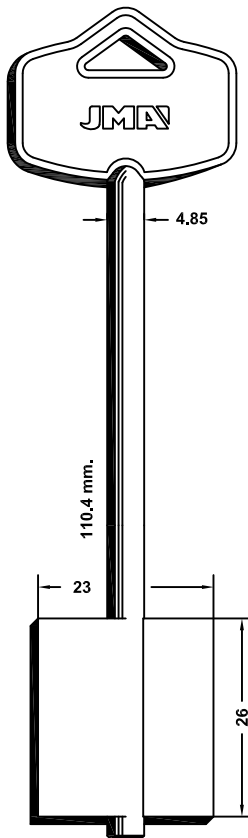

**EST-7G**

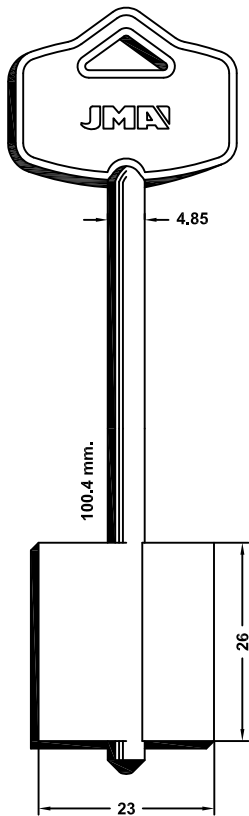

**EST-10G**

**EUROTEMPLE**

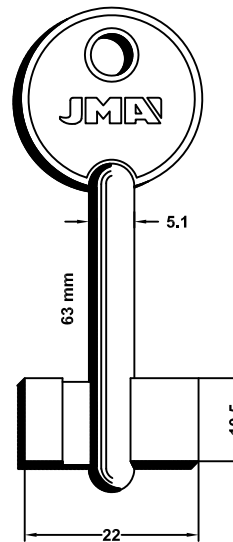

**EUT-1G**

SAG



**PARA-FOR:**  
 EUROTÉMPLE (I)  
 EZCURRA (E)

**EUROTÉMPLE**

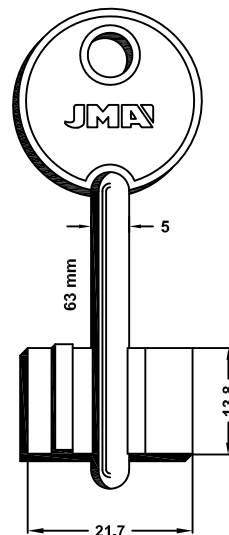
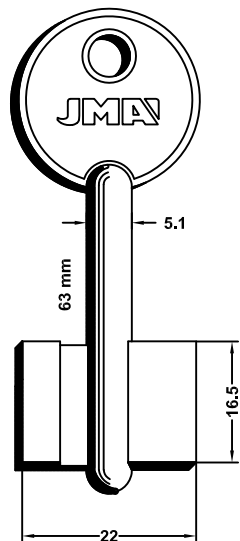

**EZCURRA**

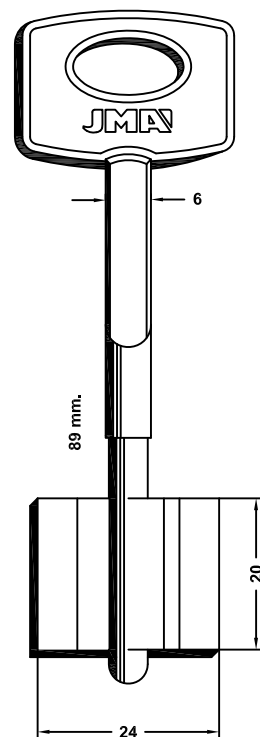
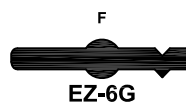
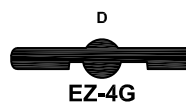
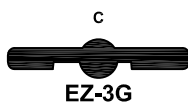
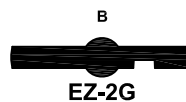
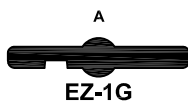
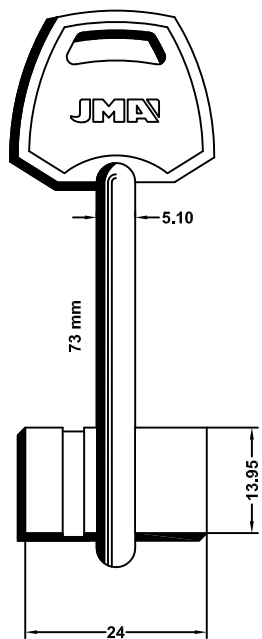

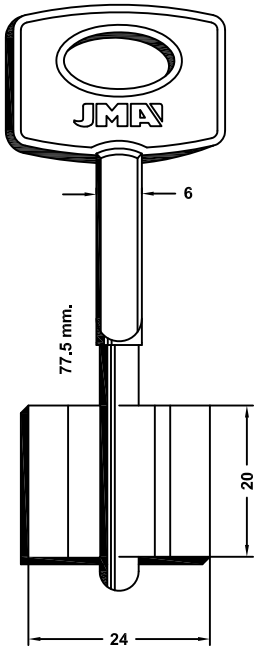
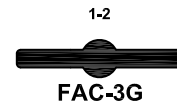
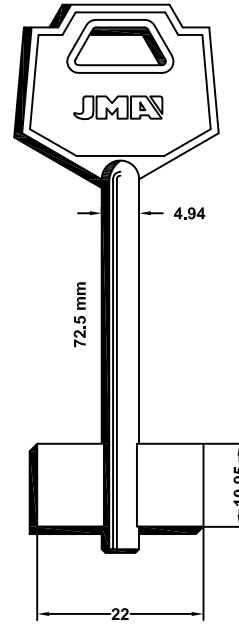
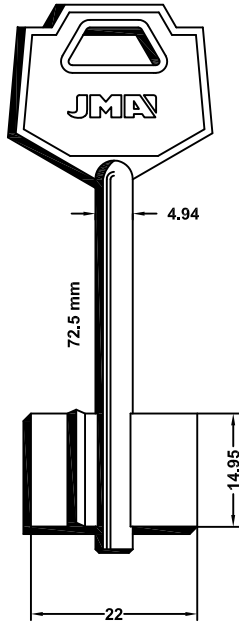
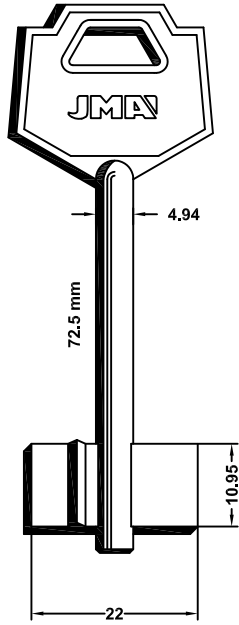
**EZCURRA****FAC****PARA-FOR:**

EZCURRA (E)

FAC (E)

FEB (I)

FETIS (E)

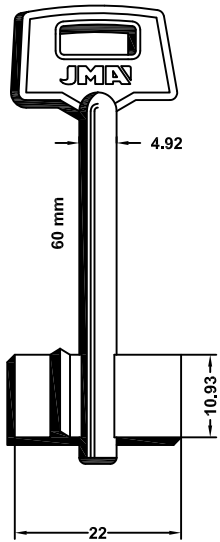
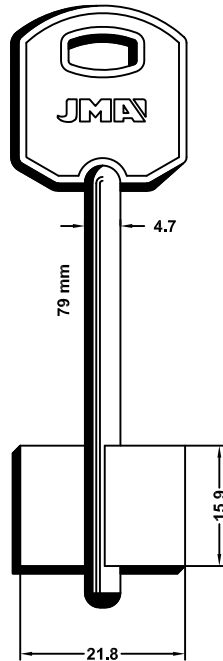
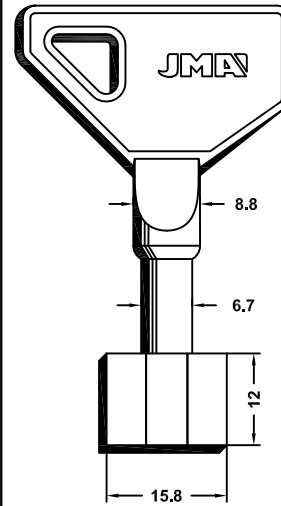
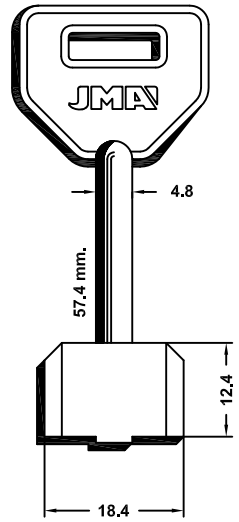
**FAC****FEB****FETIS**

PARA-FOR:

FIAM (I)

FIAM

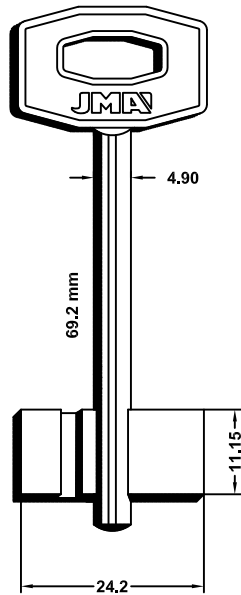

FM-1G

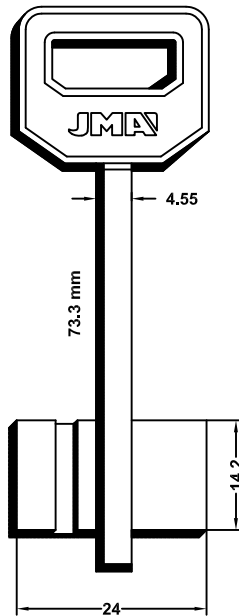

FM-2G

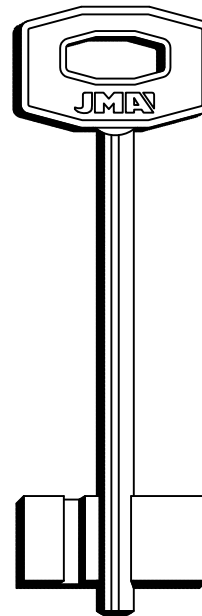

FM-3G

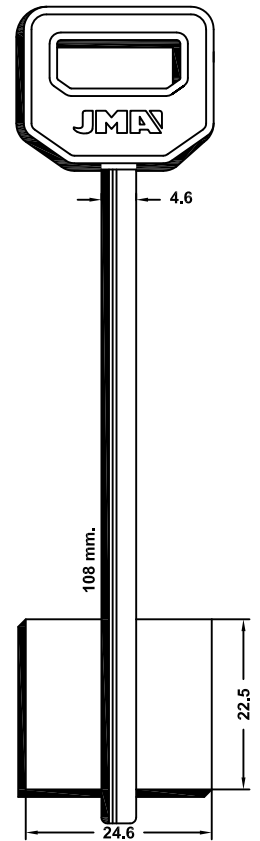

FM-4G

FIAM

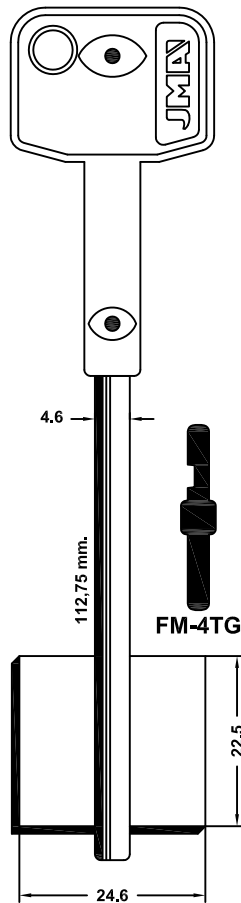

FM-4TG

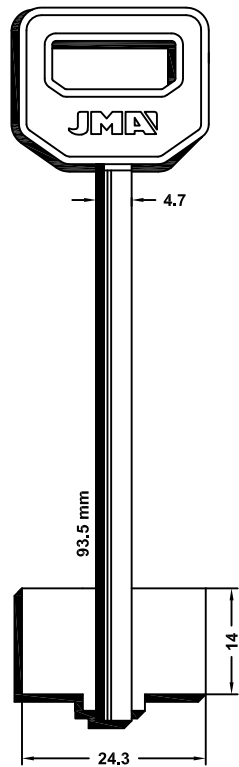

FM-5G

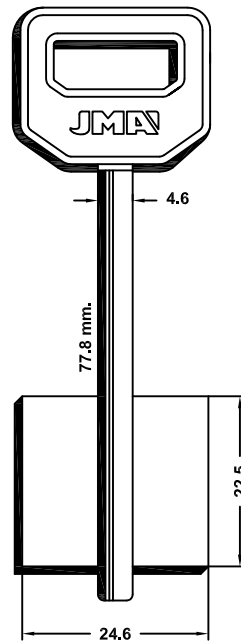

FM-6G

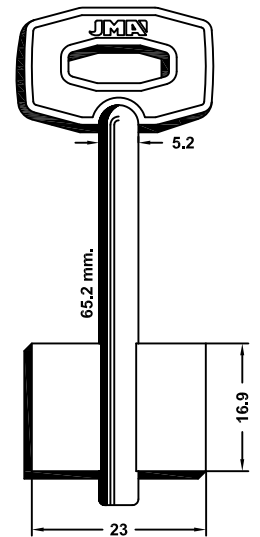

FM-7G



FIAM

PARA-FOR:

FIAM (I)

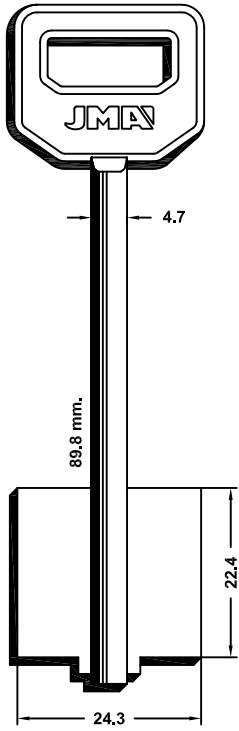

FM-8G

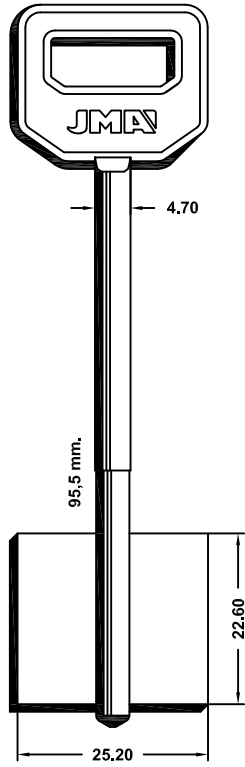

FM-13G

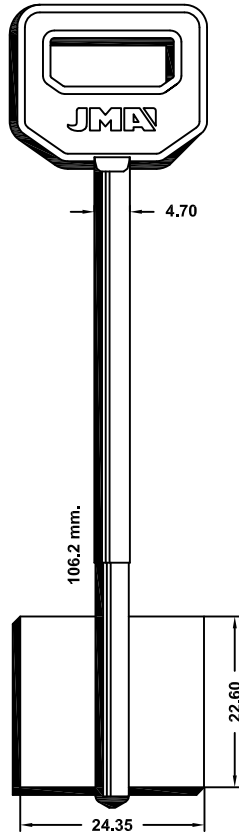

FM-14G

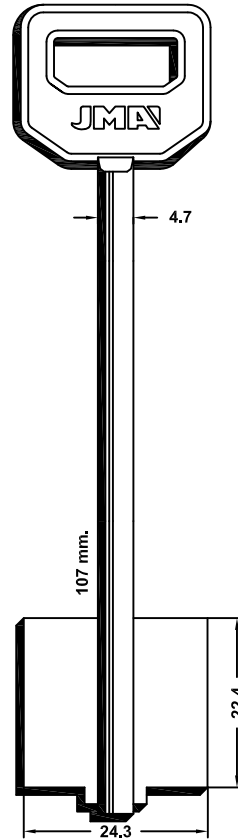

FM-15G

FIAM

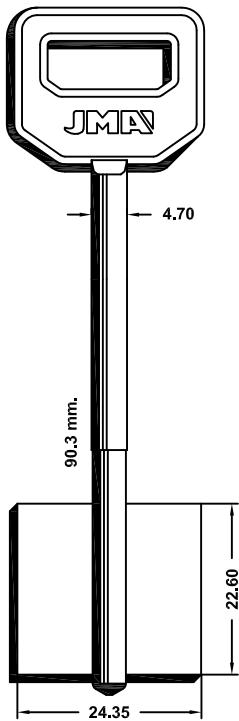

FM-16G

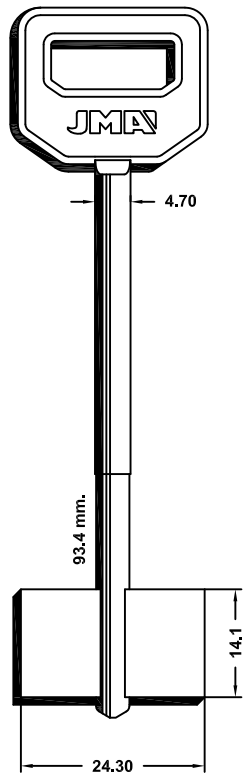

FM-17G

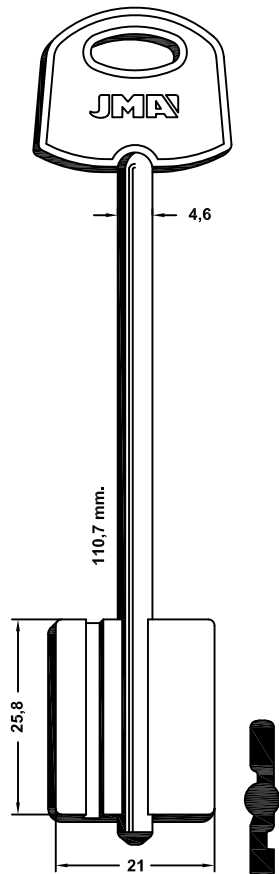

FM-20G

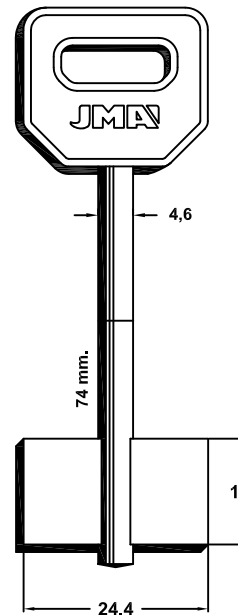

FM-21G

ISEO



**PARA-FOR:**

- FICHET (F)
- GARDIAN (RUS)
- GIMAST (I)
- GIPIS (I)
- GMG (I)

|  | FICHET         | GARDIAN        | GIMAST         |               |
|--|----------------|----------------|----------------|---------------|
|  | <p>FIC-200</p> | <p>GARD-1G</p> | <p>GIM-1TG</p> |               |
|  | GIPIS          |                | GMG            |               |
|  | <p>GPS-1G</p>  | <p>GPS-2G</p>  | <p>GMG-1G</p>  | <p>GMG-2G</p> |



**IDM**

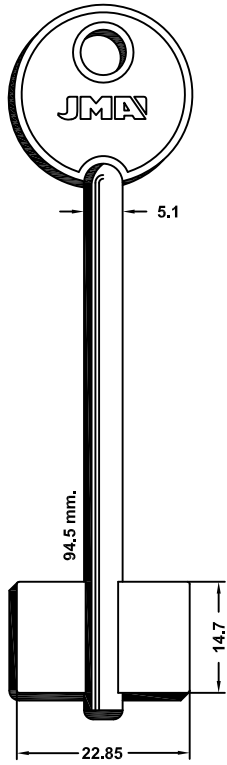

**IDM-1G**

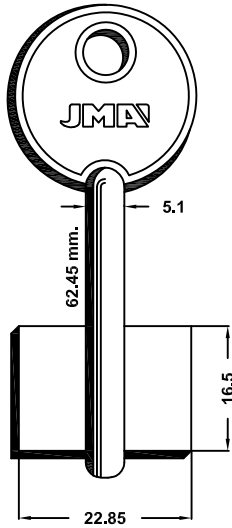

**IDM-2G**

SAG

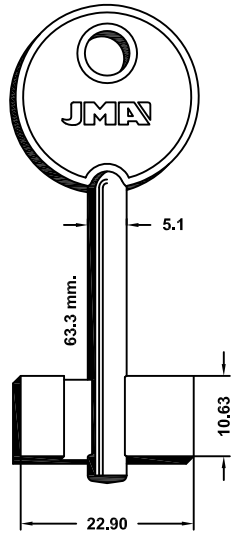

**IDM-3G**

SAG

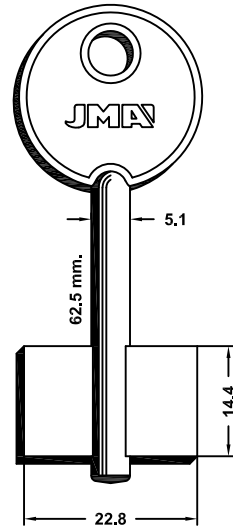

**IDM-4G**

**PARA-FOR:**

IDM (I)

ISEO (I)

**IDM**

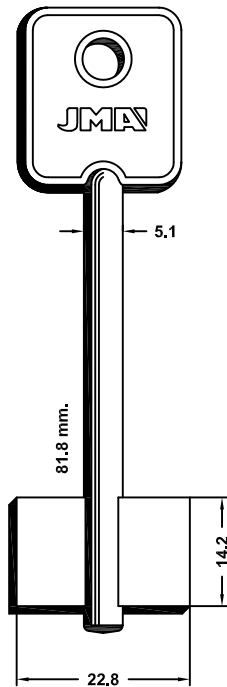

**IDM-5G**

FACEF-DOMUS

**ISEO**

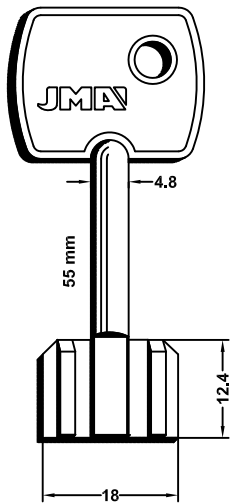

**IS-1G**

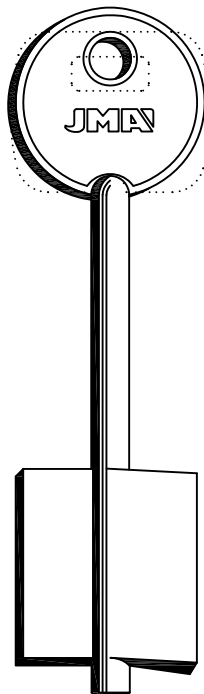

**IS-2G**

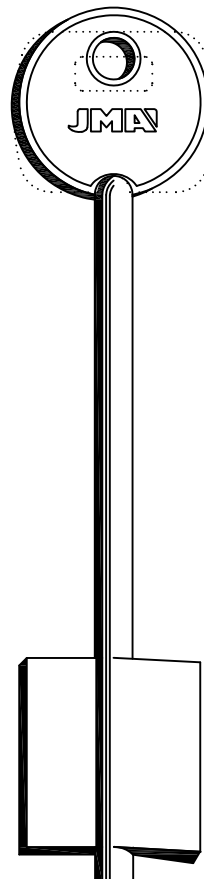

**IS-3G**



**PARA-FOR:**

ISEO (I)

ITAL (I)

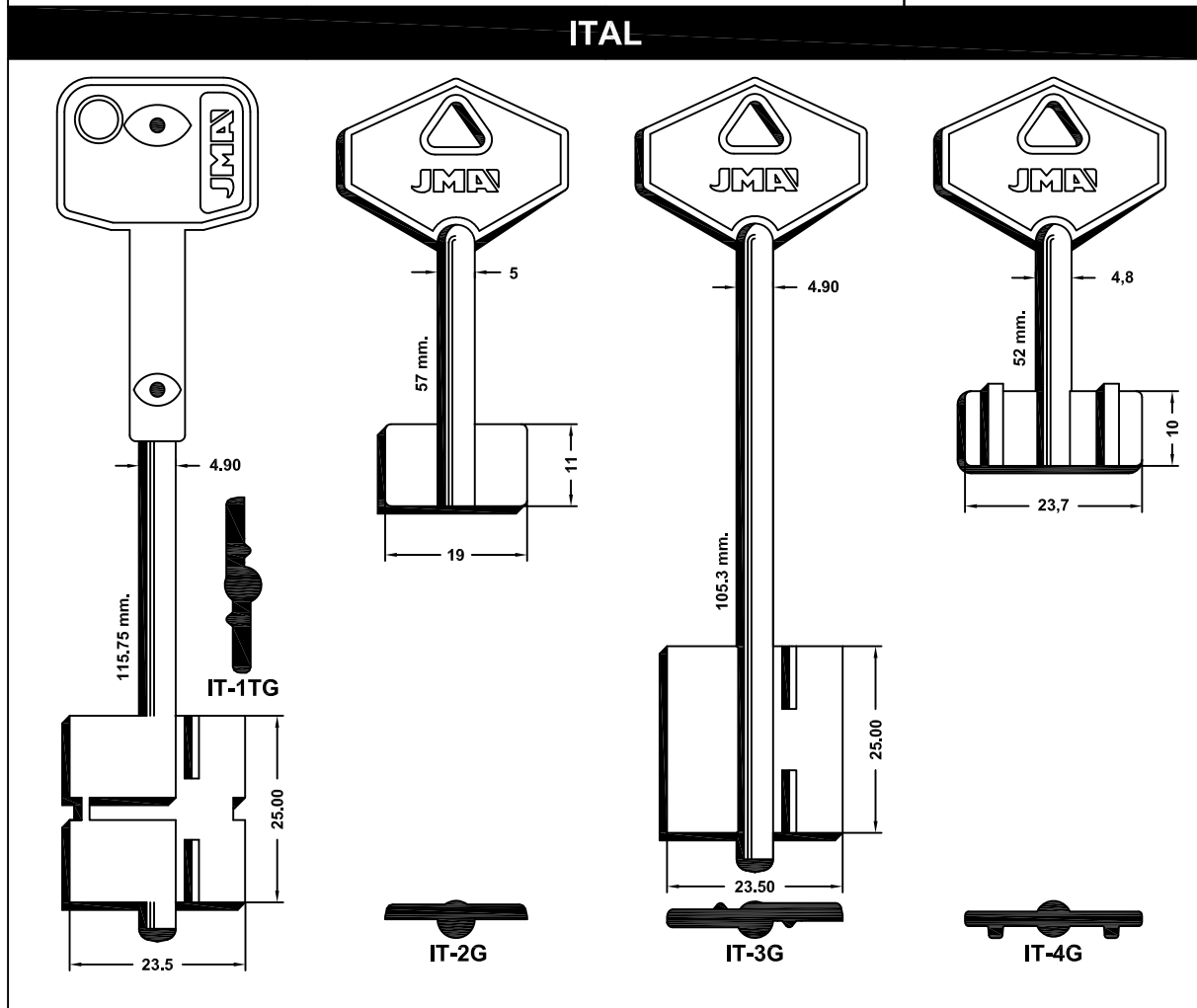
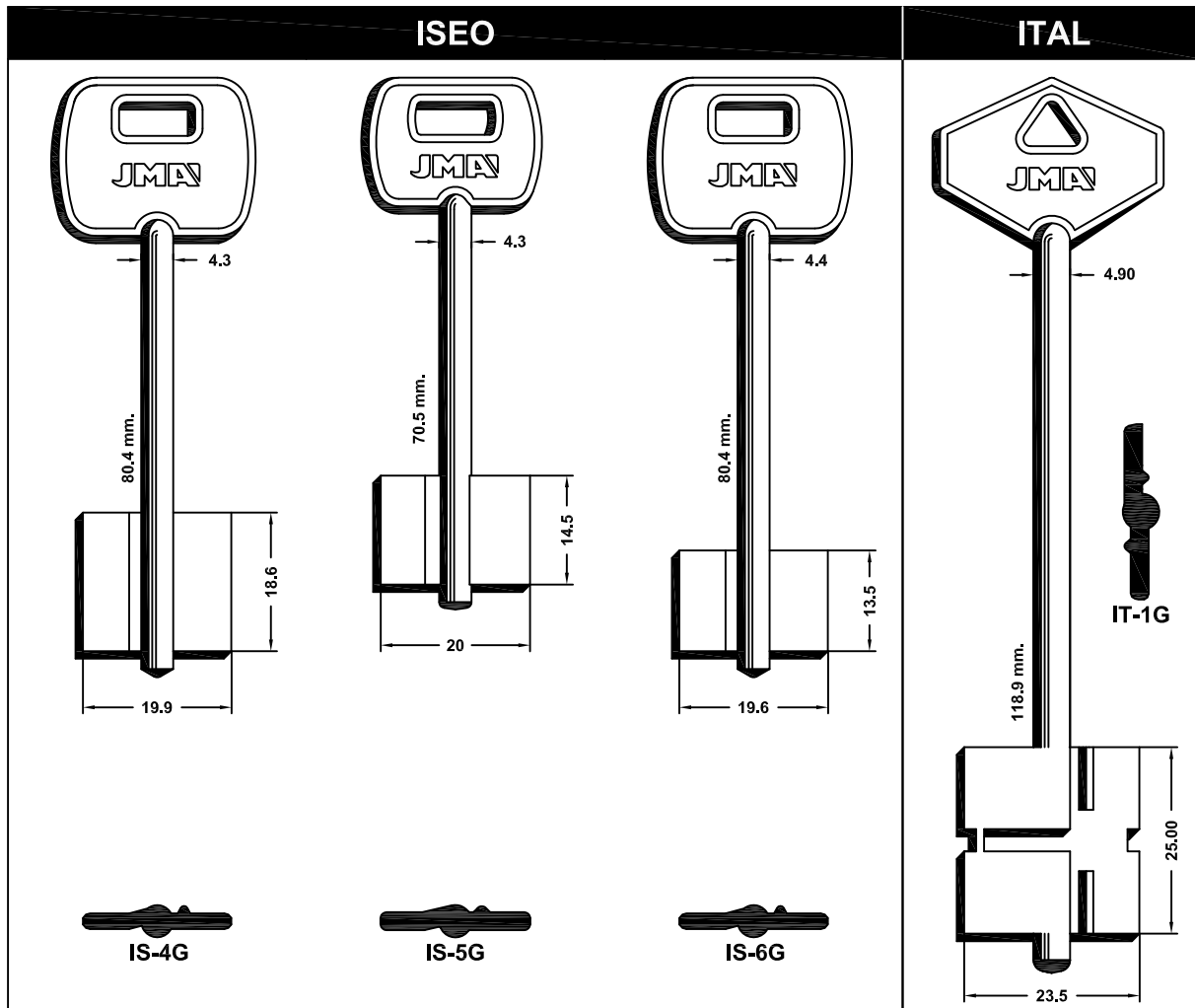



# JUWEL

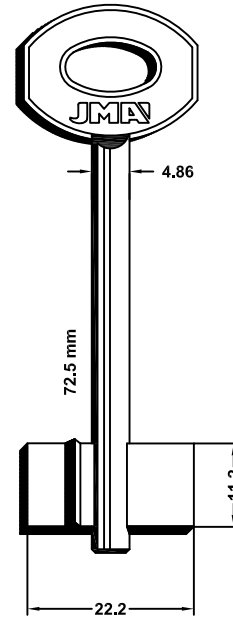
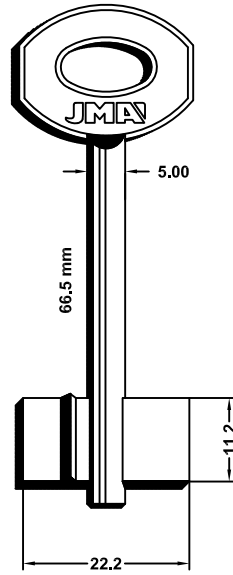
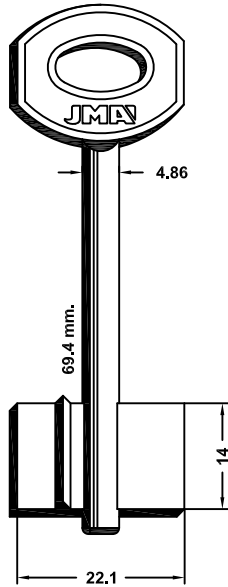
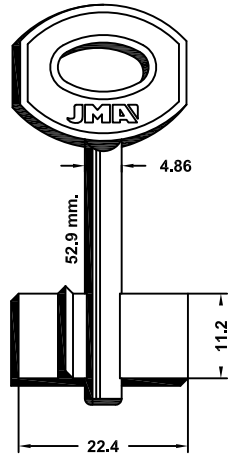

**JW-20G**

BURG-WACHTER



**JW-30G**

BURG-WACHTER



**JW-40G**

BURG-WACHTER



**JW-45G**

BURG-WACHTER

# JUWEL

# KALE

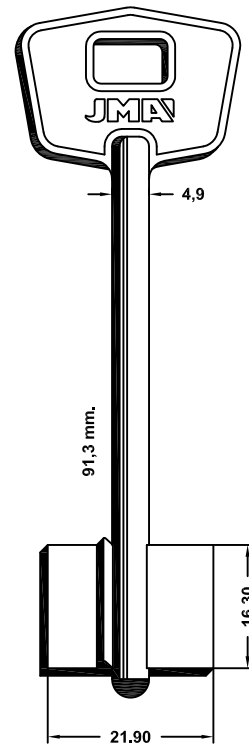
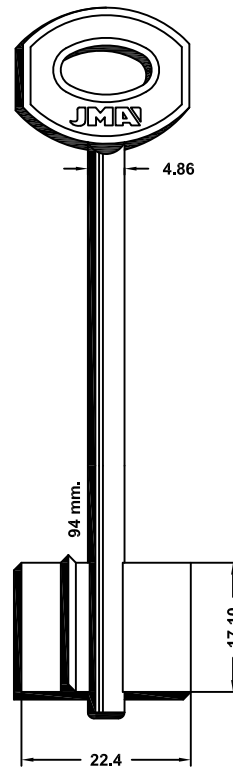
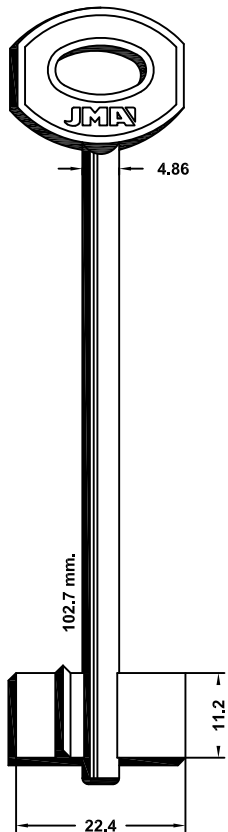
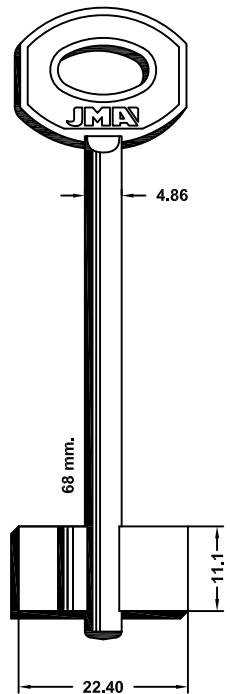

**JW-50G**



**JW-70G**

BURG-WACHTER



**JW-90G**



**KAE-1G**

# PARA-FOR:

JUWEL (I)

KALE (TR)



**PARA-FOR:**

KASSEL (I)

KERBEROS (RUS)

**KASSEL**

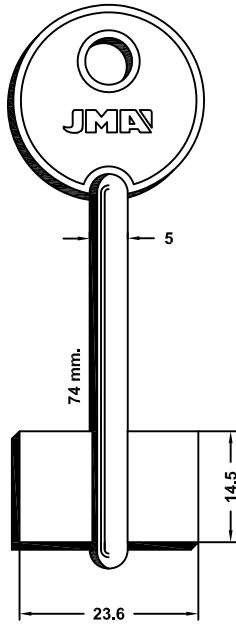

**KAS-1G**

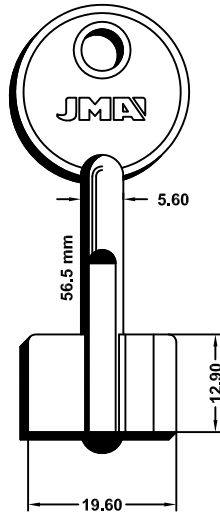

**KAS-2G**

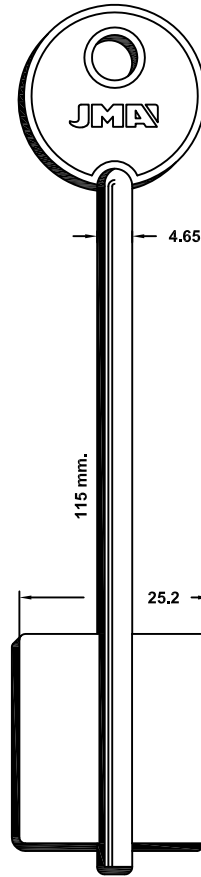

**KAS-4G**

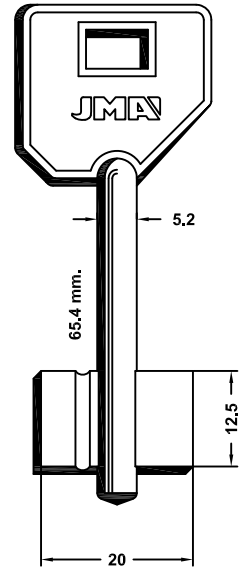

**KAS-6G**

**KERBEROS**

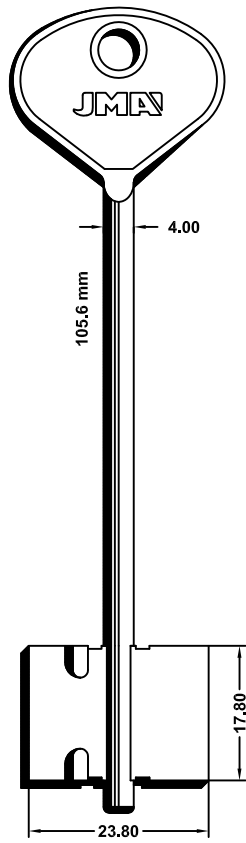

**CER-1G**

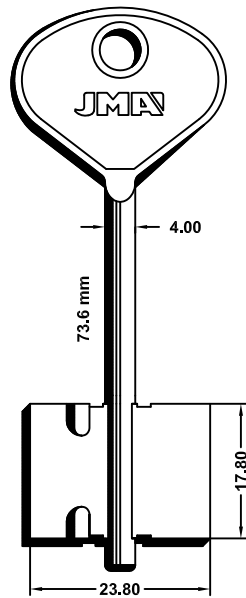

**CER-2G**

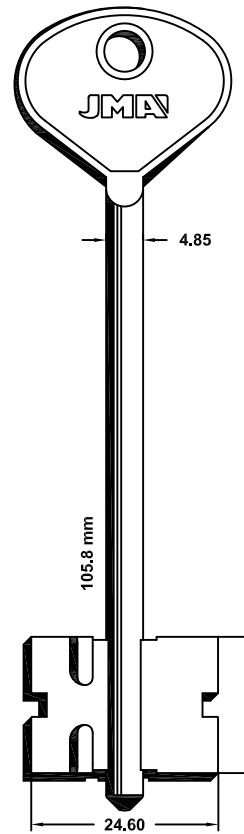

**CER-3G**

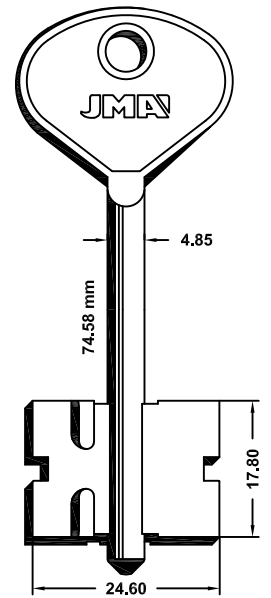

**CER-4G**

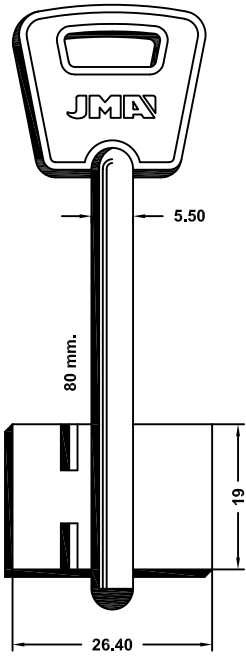
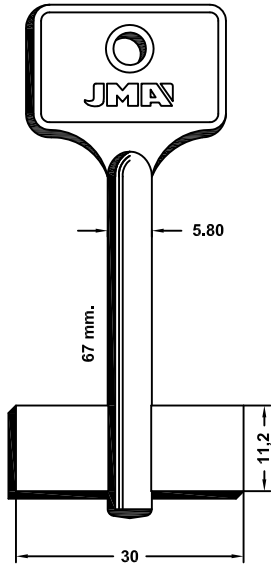
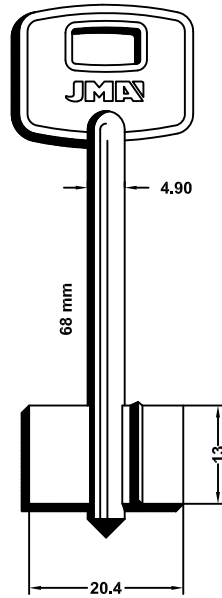
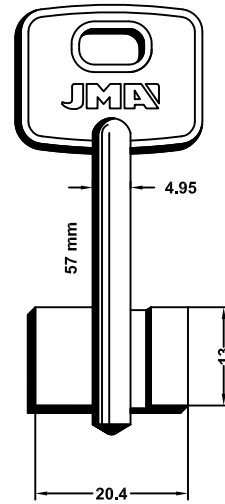

**KREPISH****KRP-1G****KURZEME****KUR-1G****LINCE****LIN-2G****LIN-3G****PARA-FOR:**

KREPISH (RUS)

KURZEME (RUS)

LINCE (E)

MCM (E)

METAL (BG)

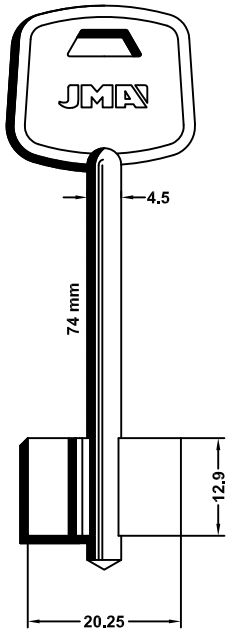
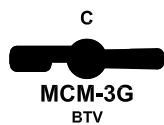
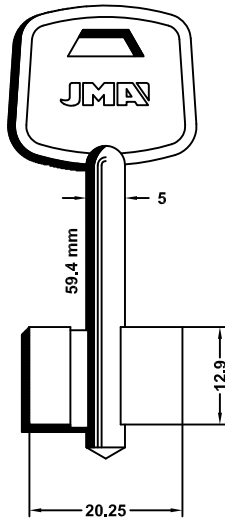
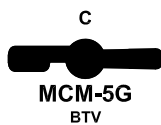
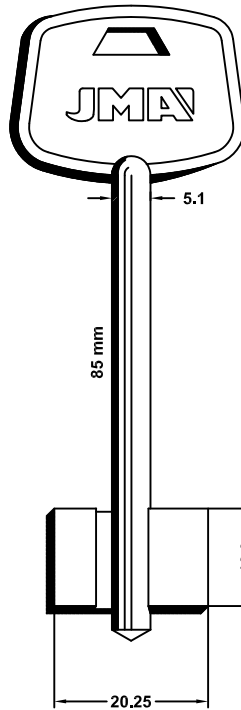
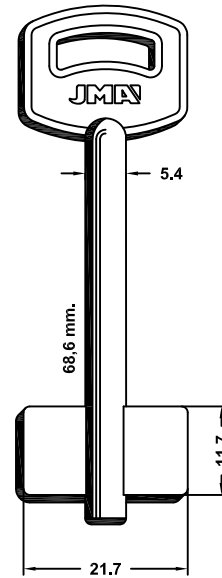
**MCM****MCM-2G****MCM-3G  
BTV****MCM-5G  
BTV****METAL****MTL-1G**

**PARA-FOR:**

METAL (BG)

MOIA (I)

MOTTURA (I)

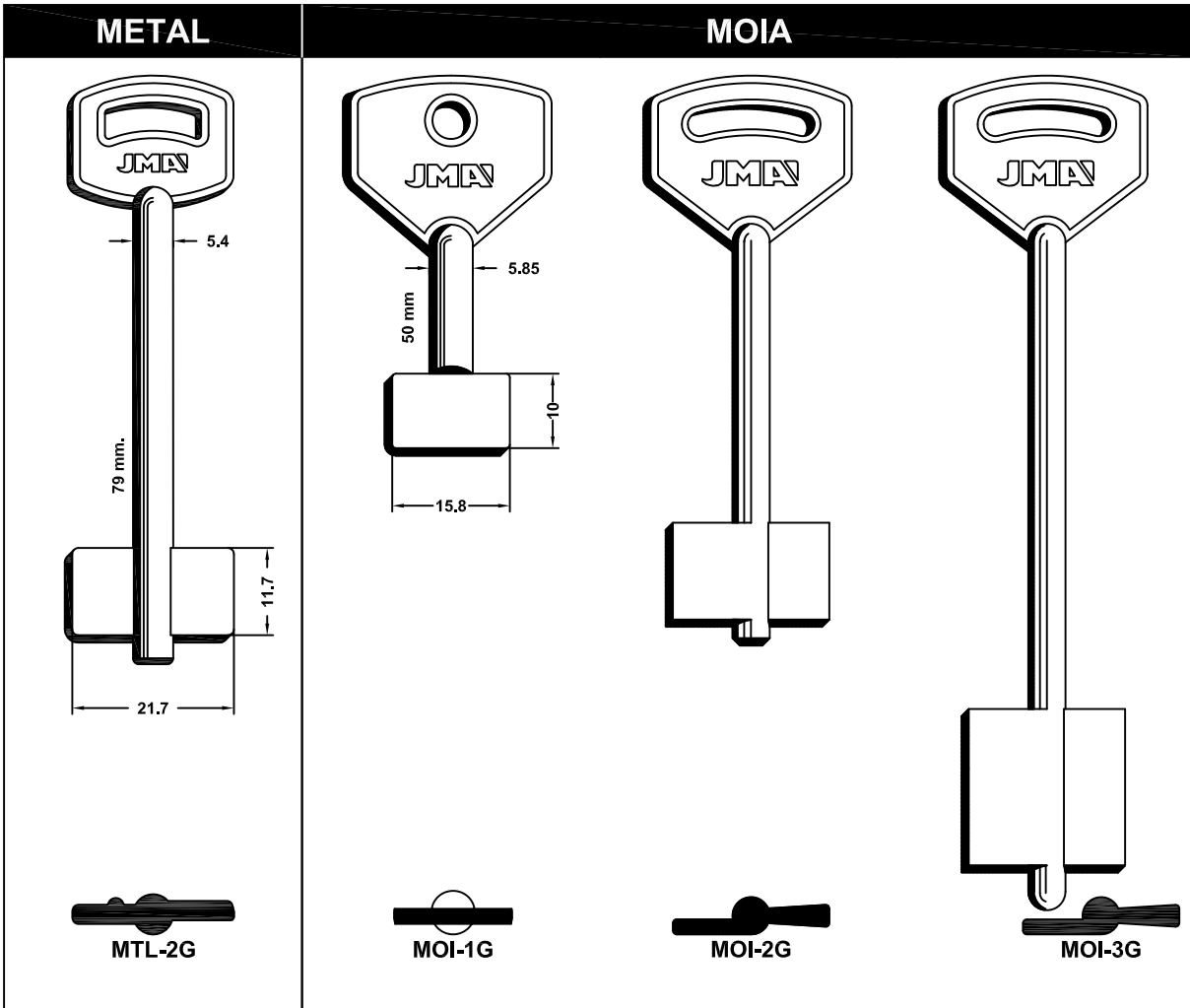

**MOTTURA**

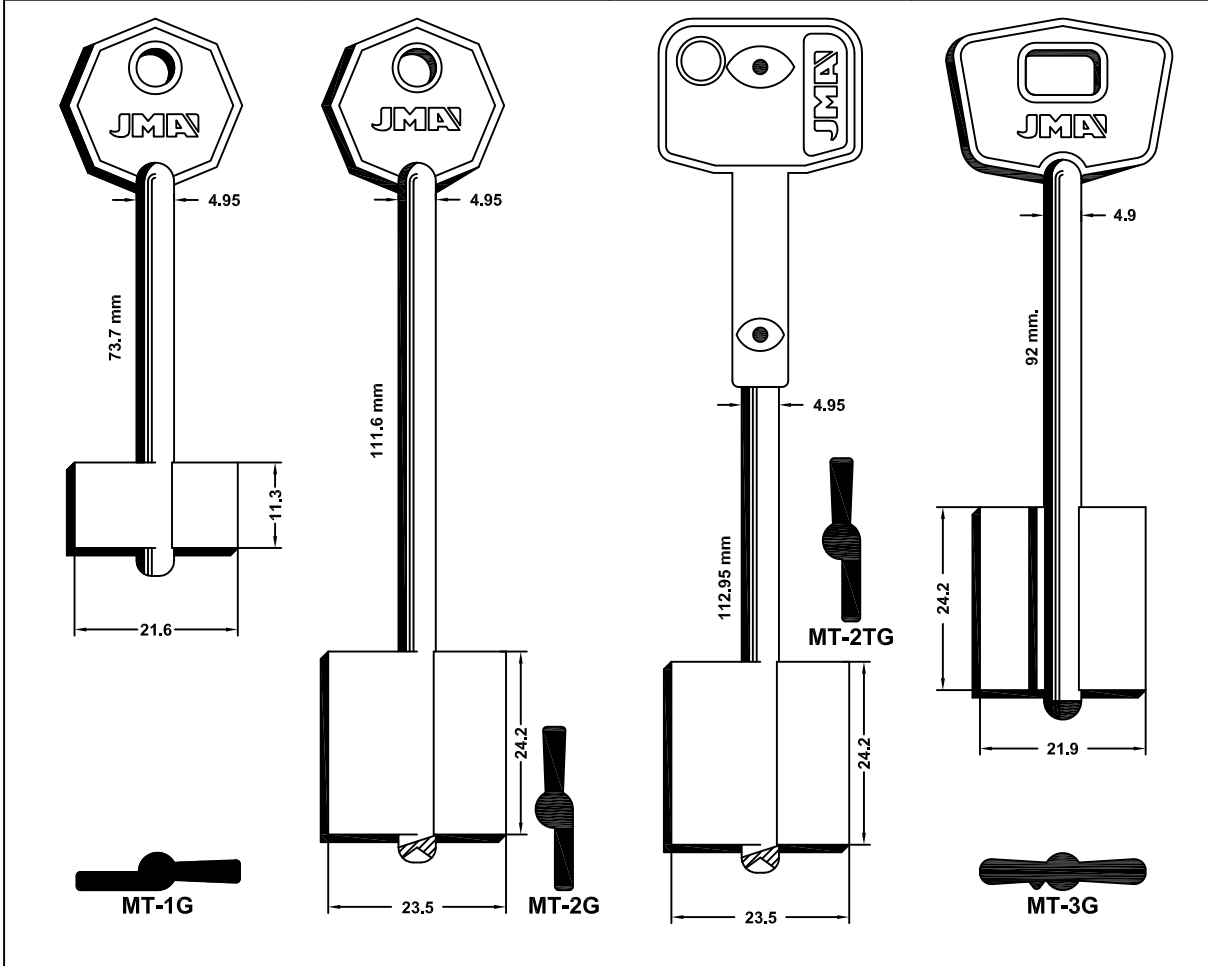

## MOTTURA

PARA-FOR:

MOTTURA (I)

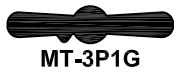
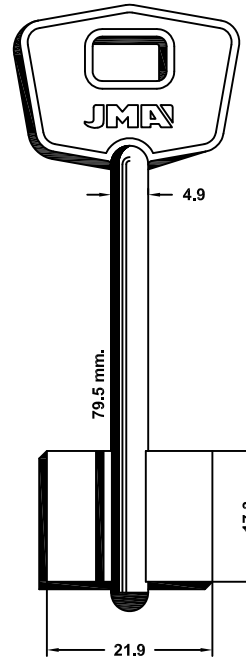
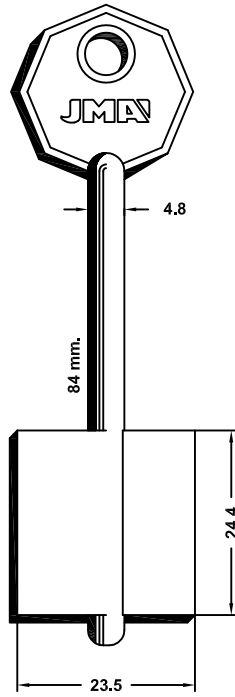
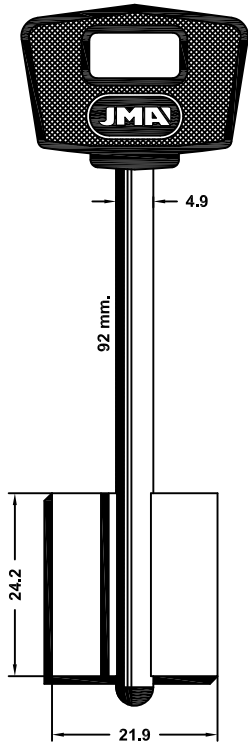
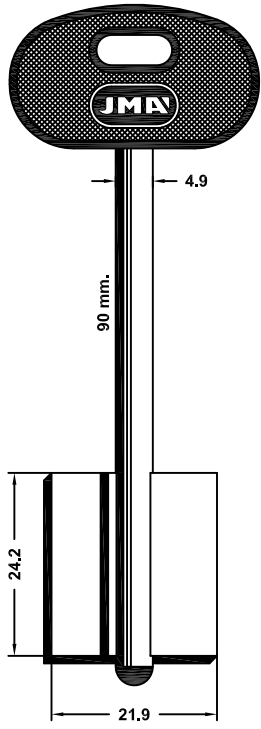

## MOTTURA

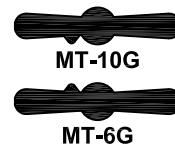
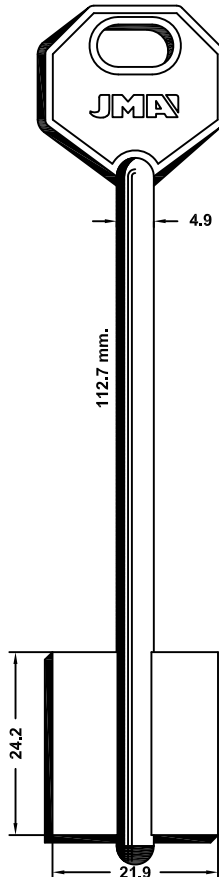
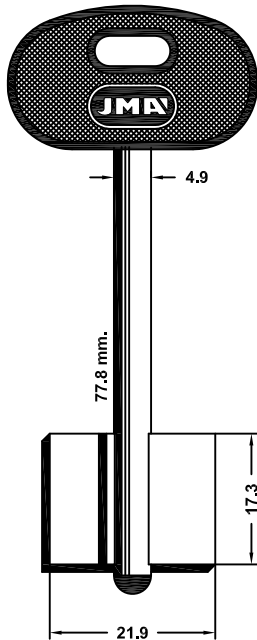

PARA-FOR:  
MOTTURA (I)

MOTTURA

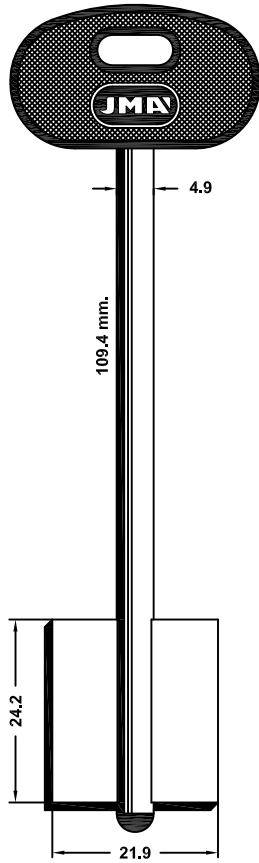

MT-10P1G  
MT-6P1G

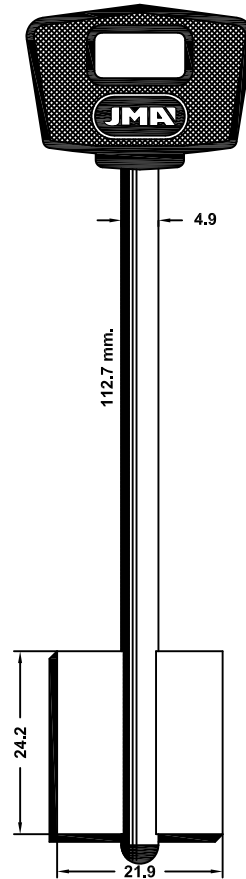

MT-10PG  
MT-6PG

MOTTURA

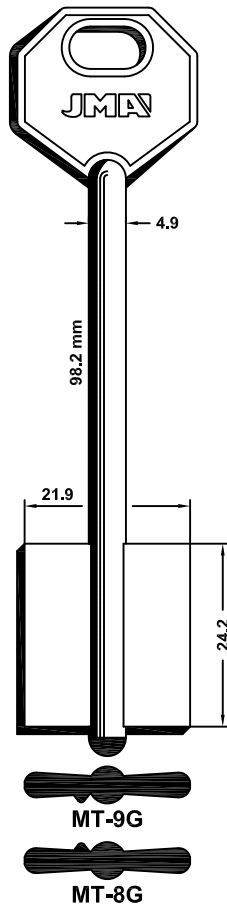

MT-9G  
MT-8G

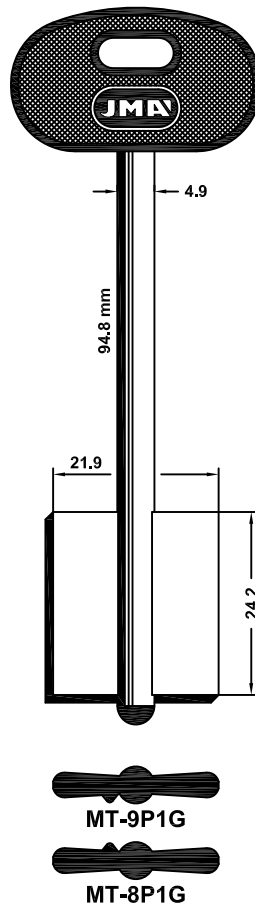

MT-9P1G  
MT-8P1G

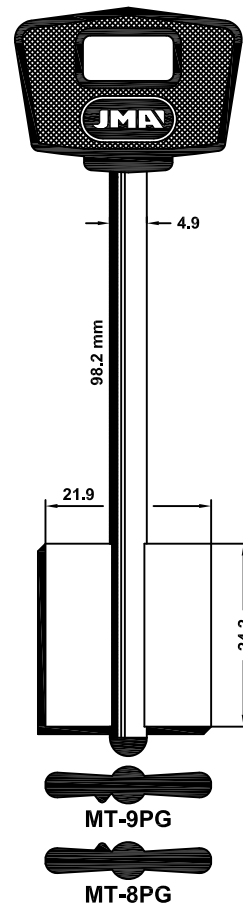

MT-9PG  
MT-8PG

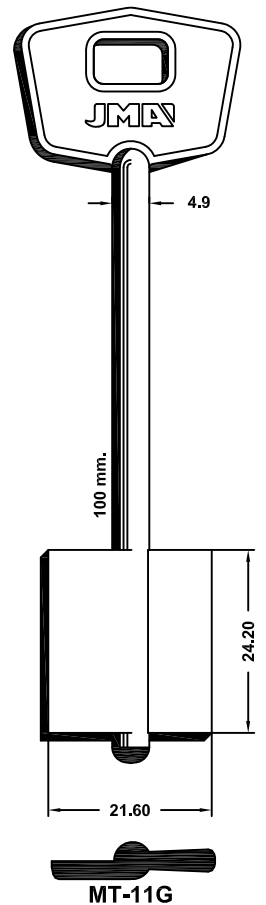

MT-11G



# MOTTURA

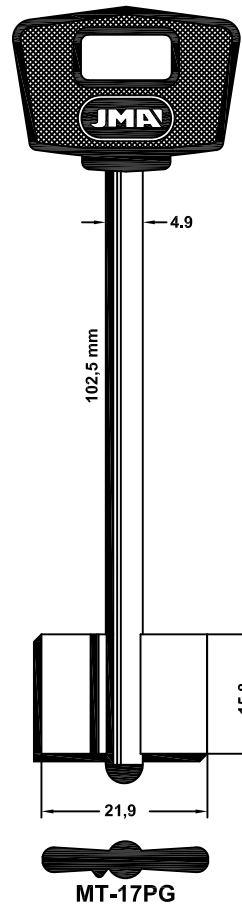
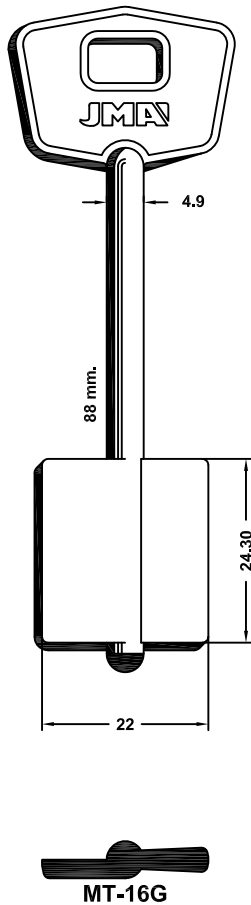
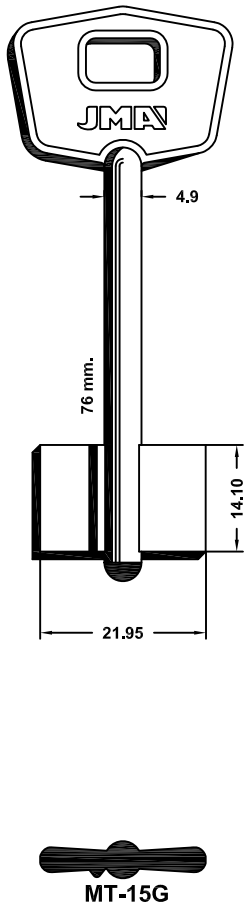
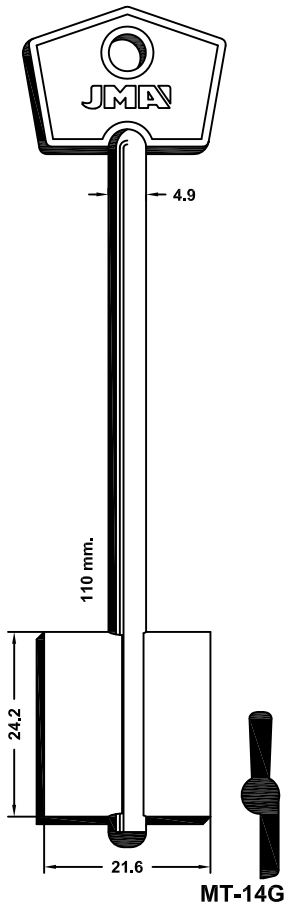

# PARA-FOR:

MOTTURA (I)

OMEC (I)

ORENGO (E)

PATRONE (I)

## MOTTURA

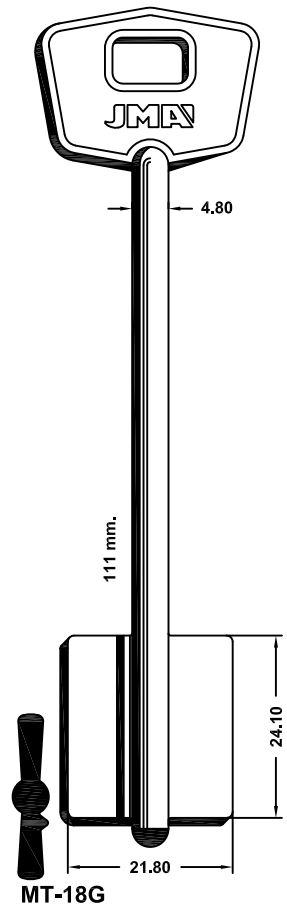

## OMEC

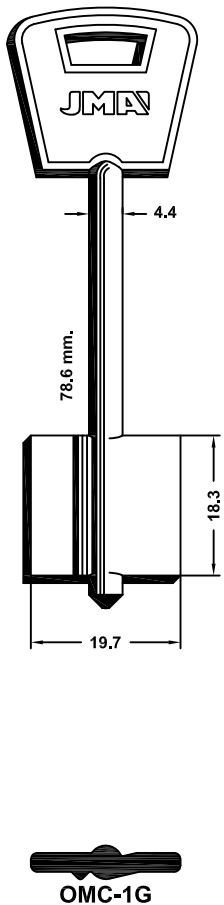

## ORENGO

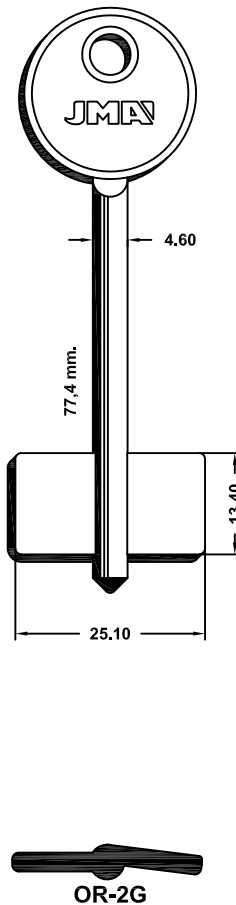

## PATRONE

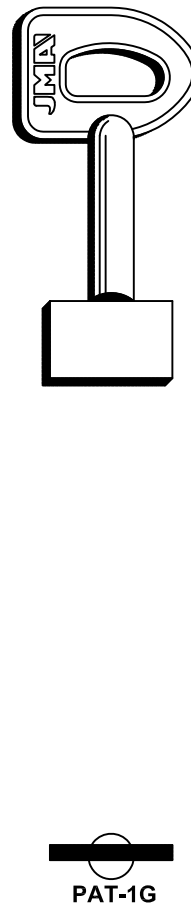

CF



PARA-FOR:

POTENT (I)

POTENT

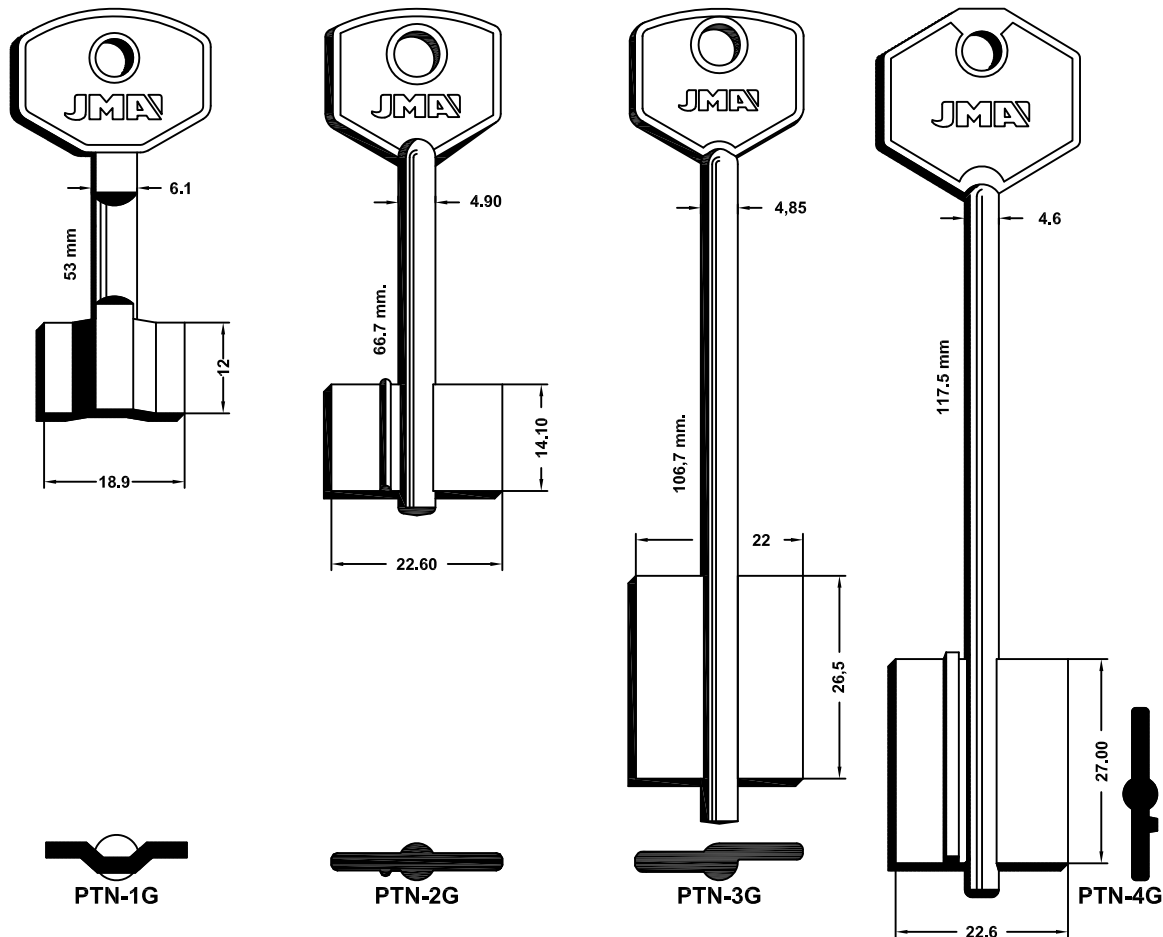

POTENT

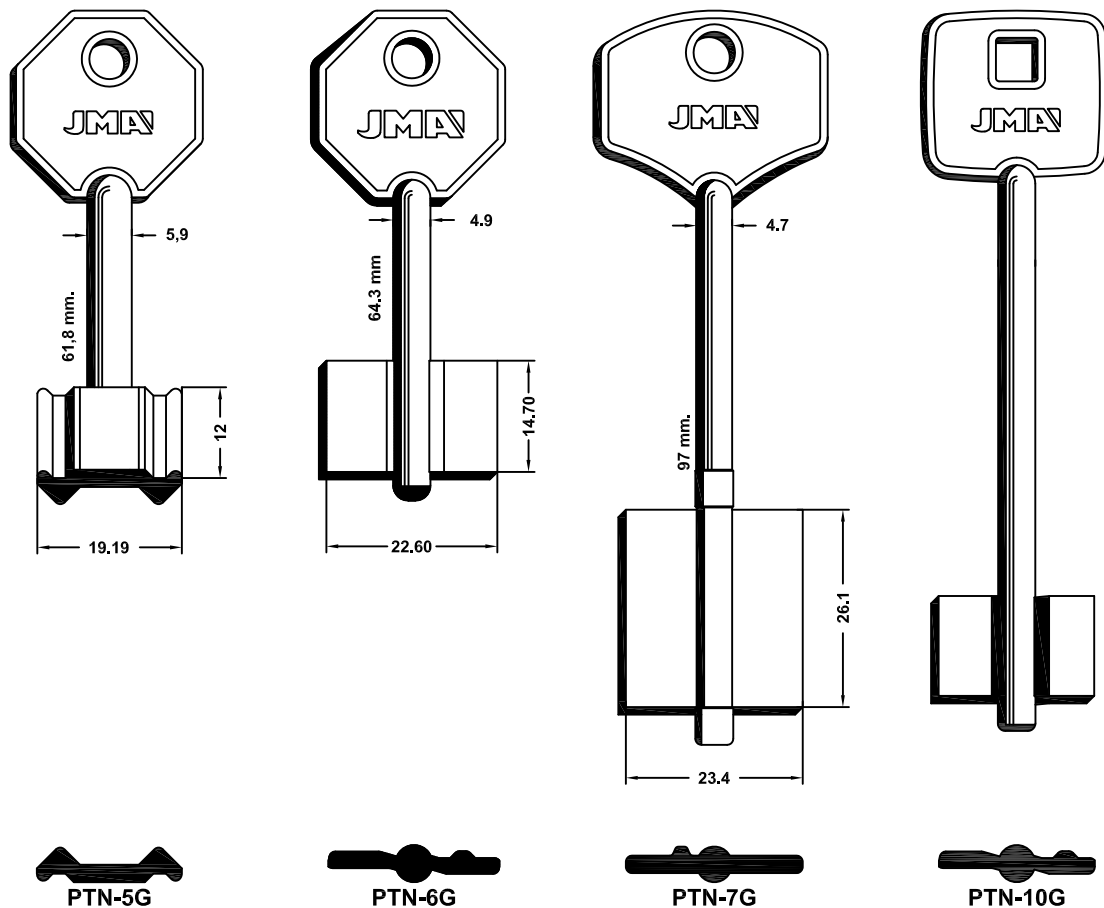



# POTENT

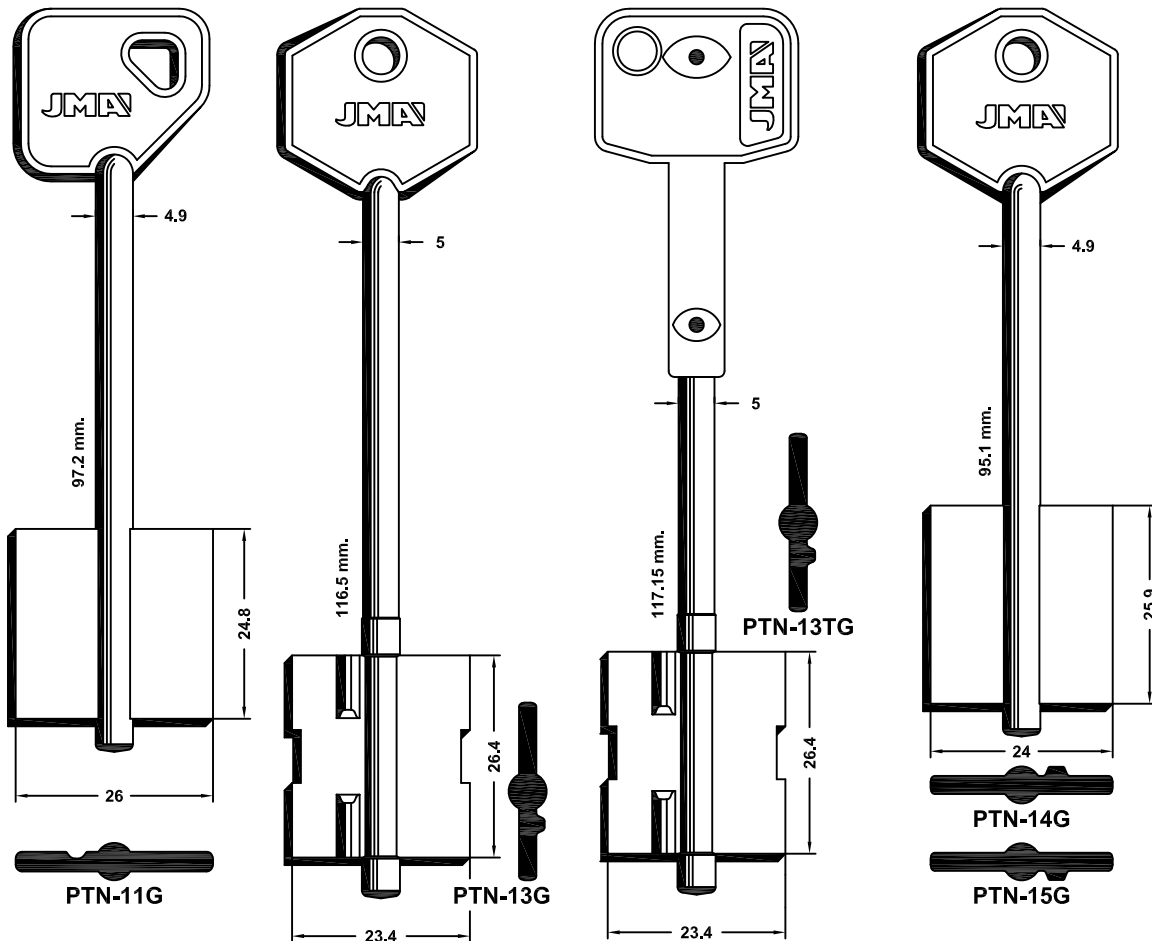

# PARA-FOR:

POTENT (I)

PREFER (I)

REVI (E)

# PREFER

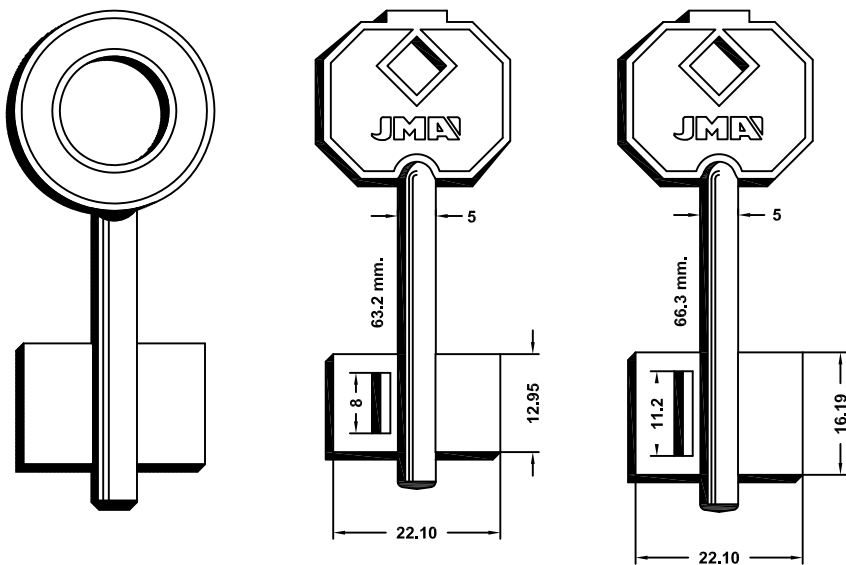

# REVI

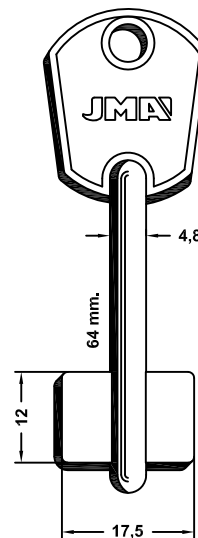

PR-1G



PR-3G



PR-4G



REVI-1G



**PARA-FOR:**

RIGAL (RUS)

RUBEN (RUS)

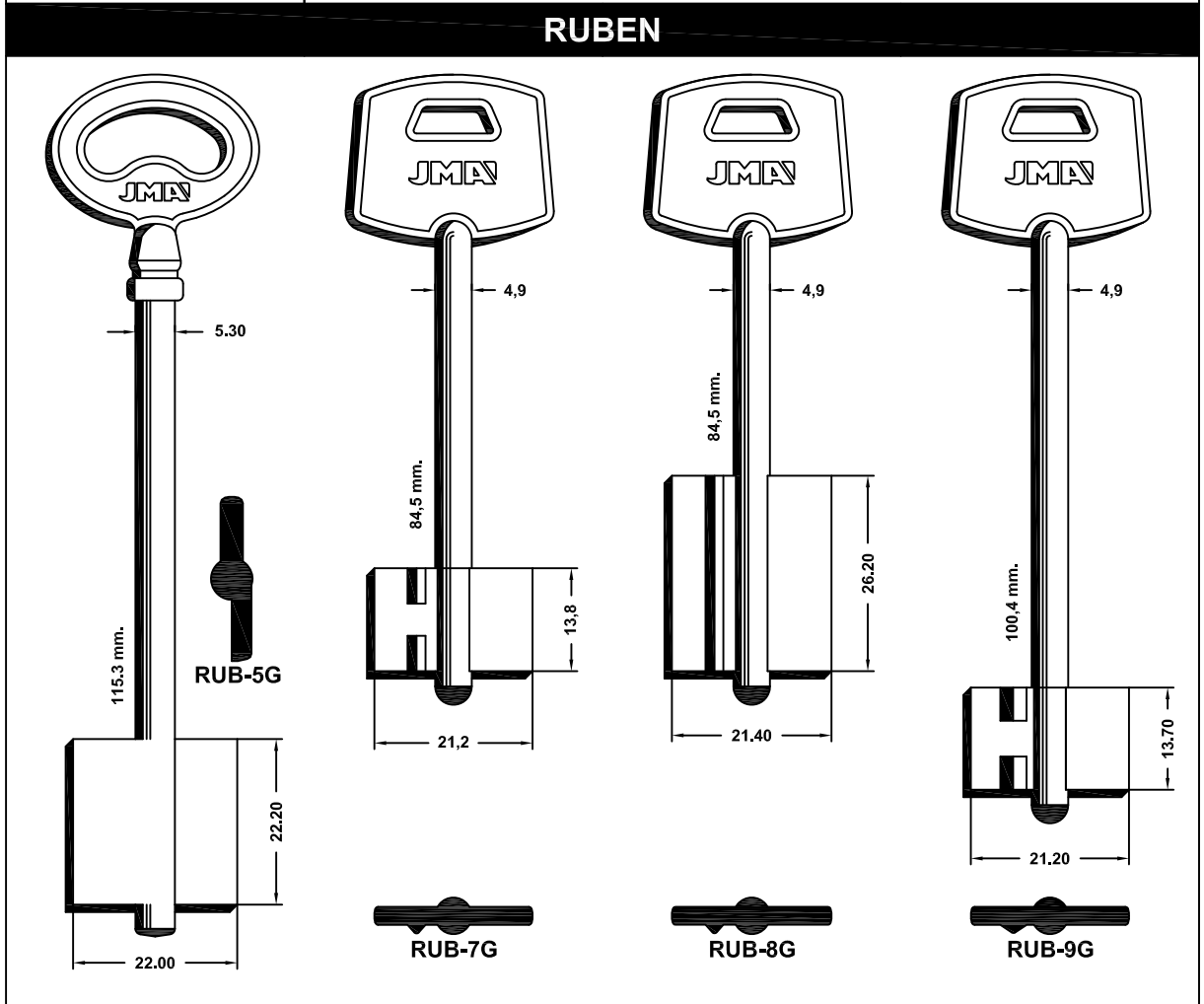
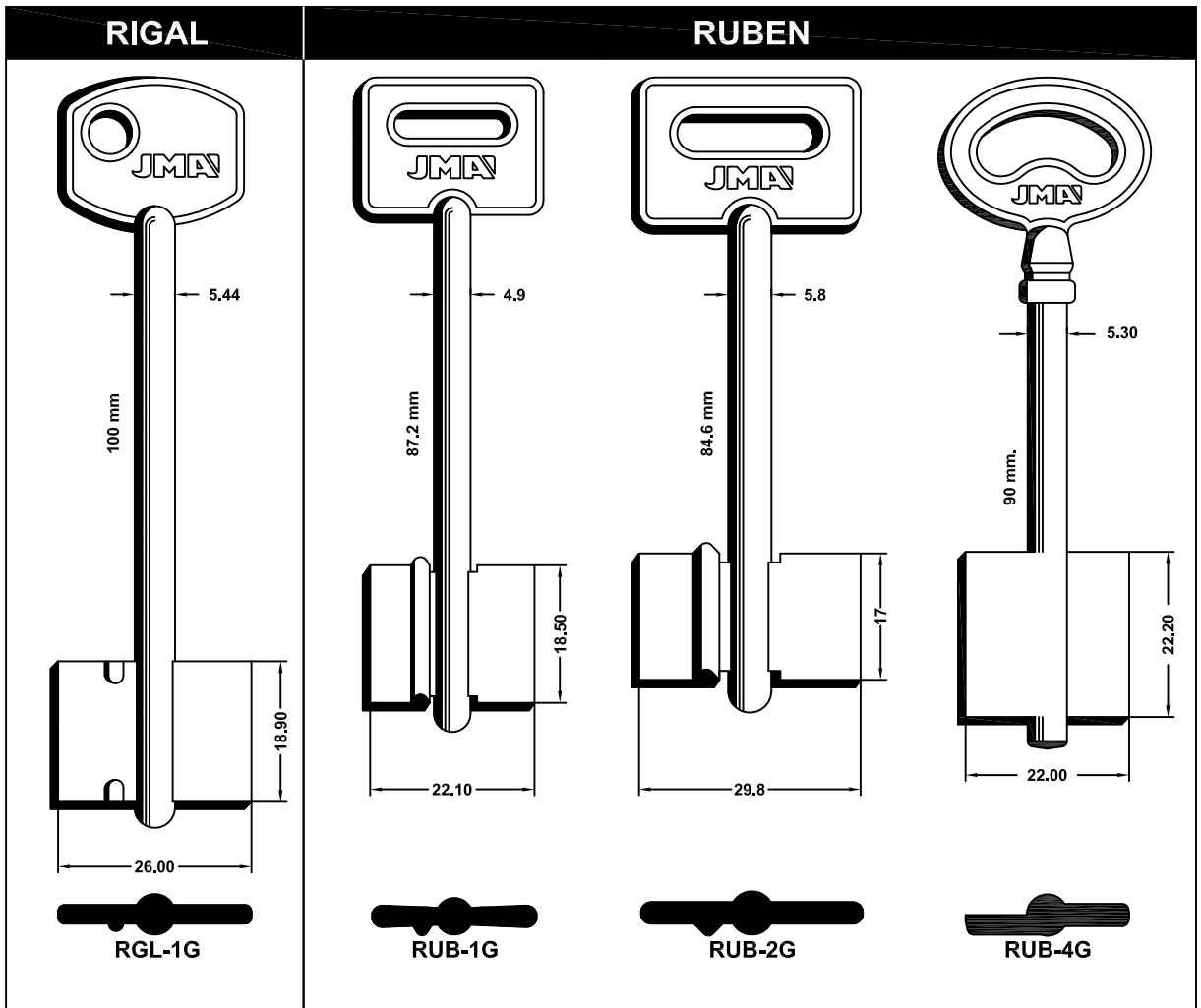

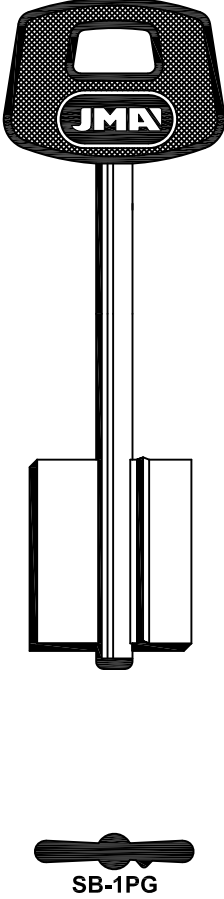
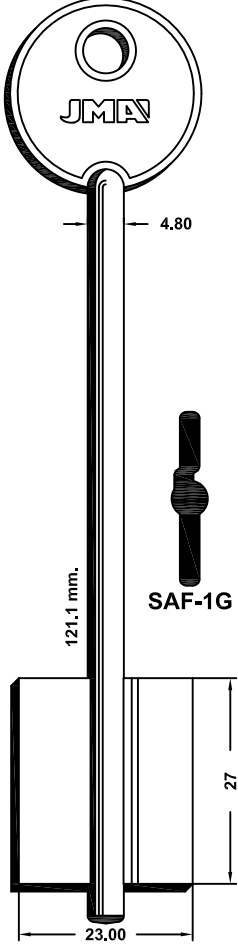
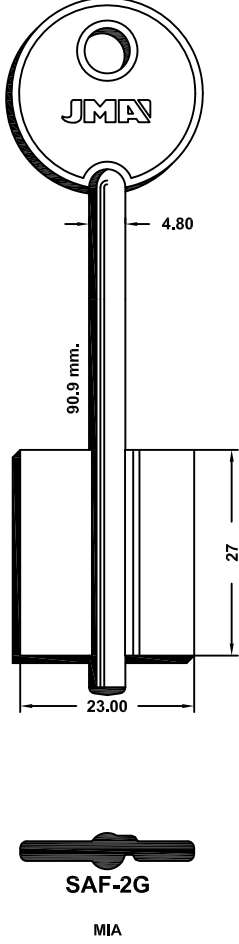
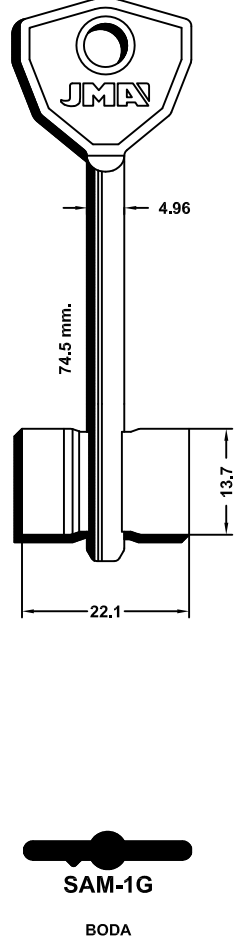
| SAB   | SAFE   |   | SAM  |
|---|--|---|--|
|  |  <p>SAF-1G</p> |  <p>SAF-2G</p> <p>MIA</p> |  <p>SAM-1G</p> <p>BODA</p> |

**PARA-FOR:**

- SAB (I)
- SAFE (I)
- SAM (RUS)
- SECUREMME (I)

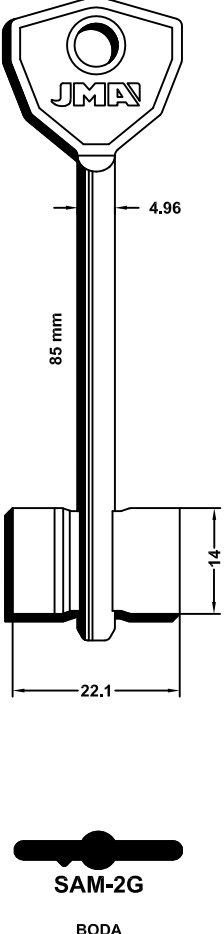
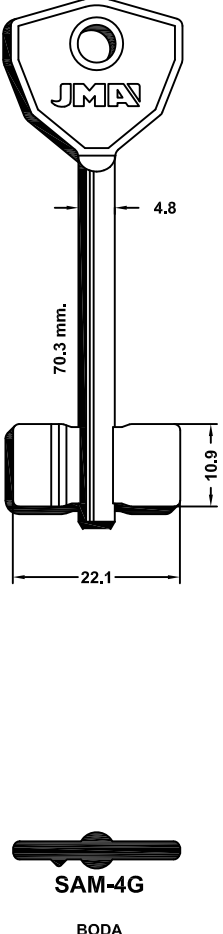
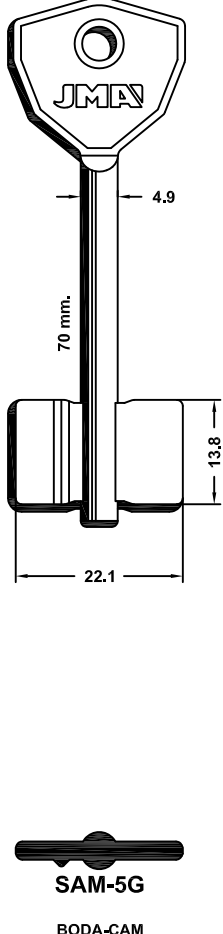
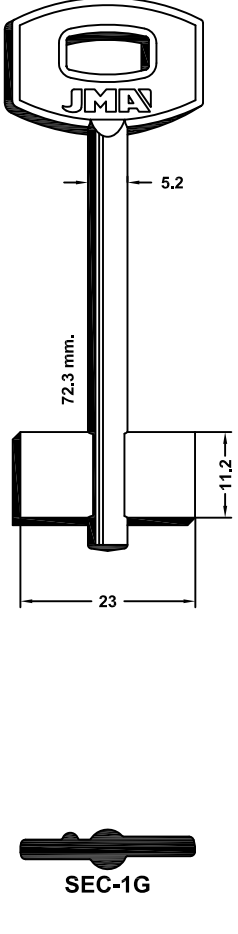
| SAM   |   |   | SECUREMME   |
|---|---|---|---|
|  <p>SAM-2G</p> <p>BODA</p> |  <p>SAM-4G</p> <p>BODA</p> |  <p>SAM-5G</p> <p>BODA-CAM</p> |  <p>SEC-1G</p> |



**PARA-FOR:**

**SECUREMME**

SECUREMME (I)

SERMEC (I)

SIAS (I)

SIBI (I)

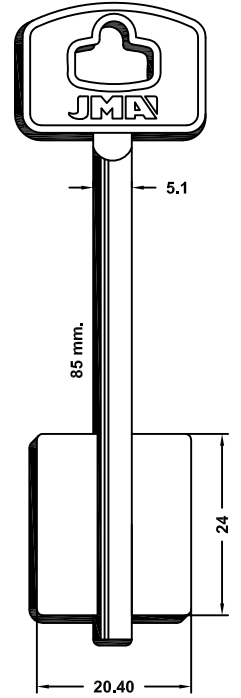
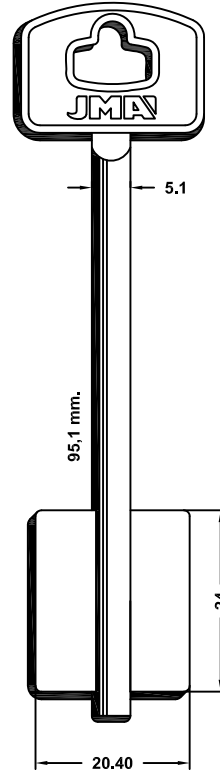
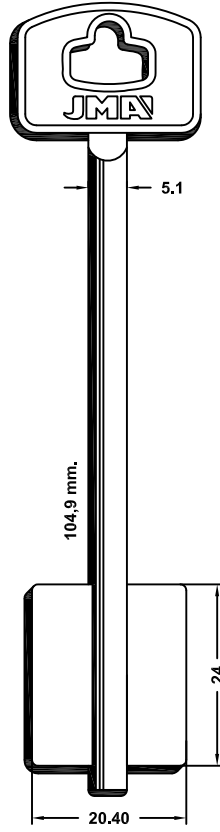
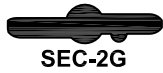
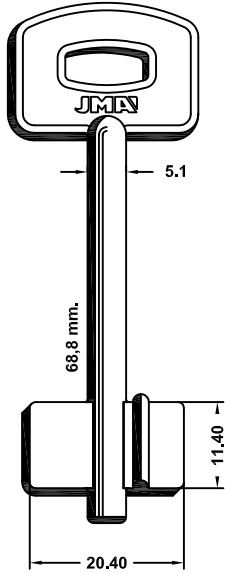

**SERMEC**

**SIAS**

**SIBI**

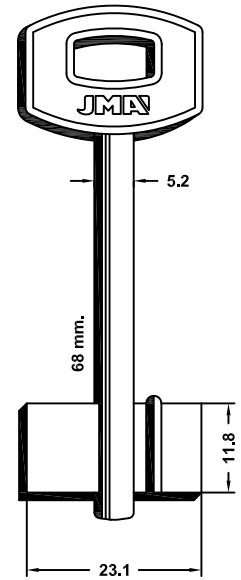
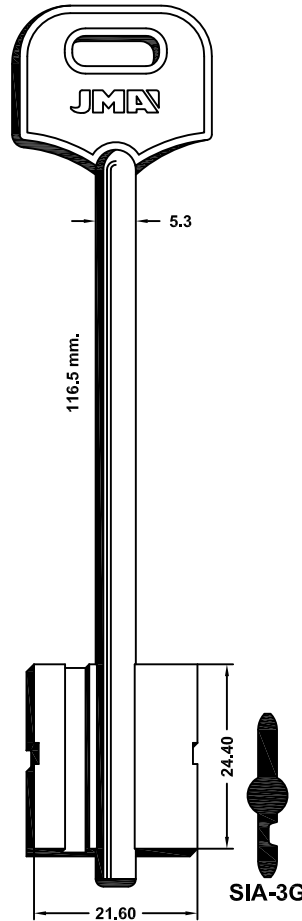
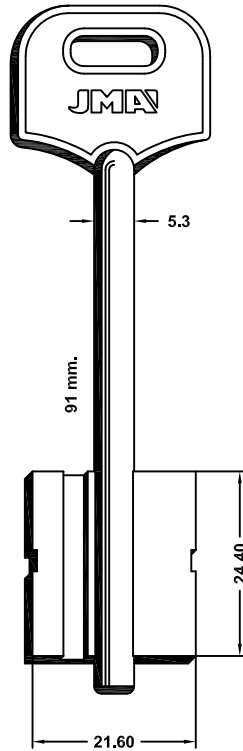
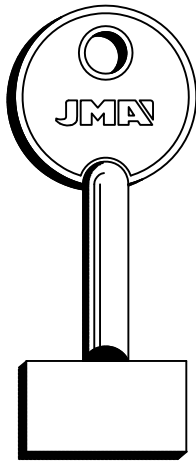

**SIBI**

**SIDERAL**

**PARA-FOR:**

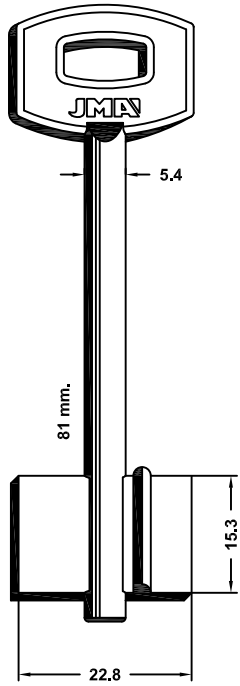

**SIB-3G**

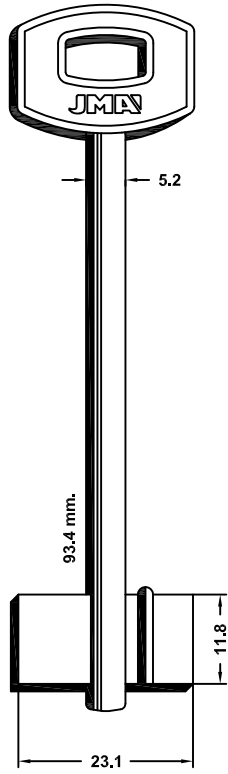

**SIB-4G**

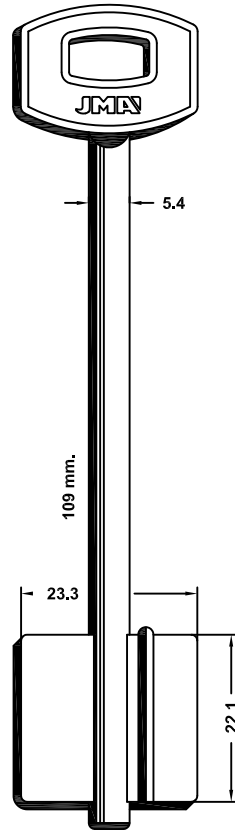

**SIB-5G**

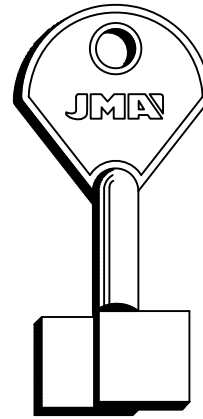

**SDR-1G**

SIBI (I)

SIDERAL (I)

TECSESA (E)

TESIO (I)

**SIDERAL**

**TECSESA**

**TESIO**

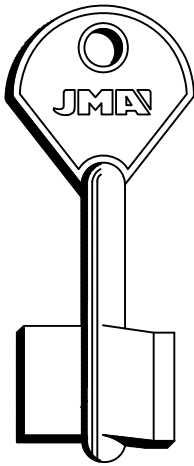

**SDR-2G**

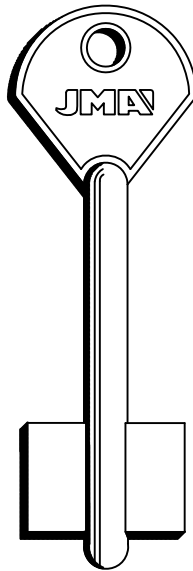

**SDR-3G**

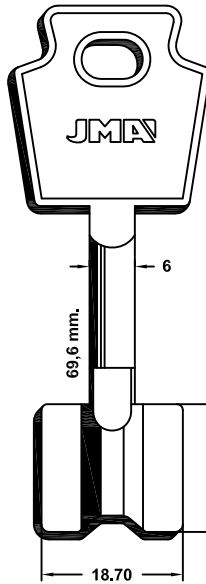

**TEC-1G**

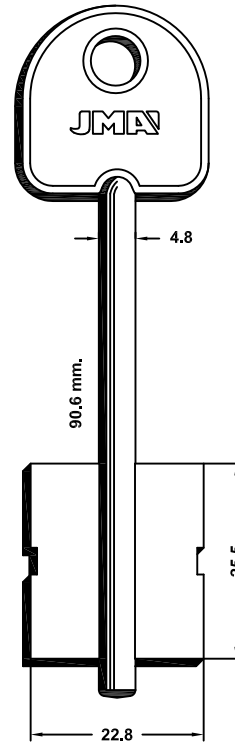

**TSI-1G**



**PARA-FOR:**





TITANIO (I)



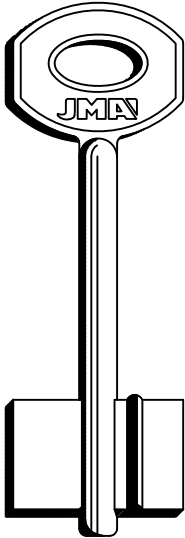
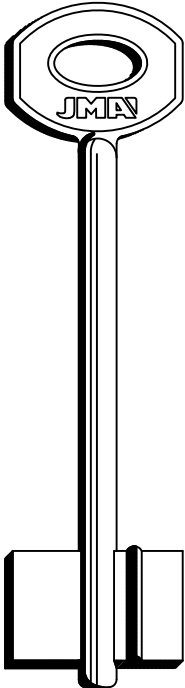
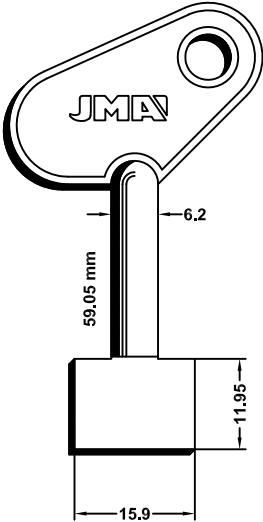
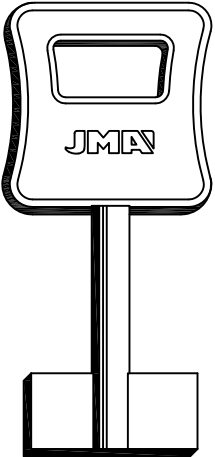

TOVER (E)

4 TR (I)

TUSHINO (RUS)

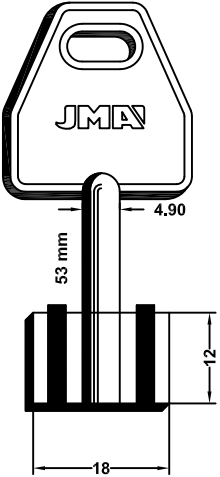
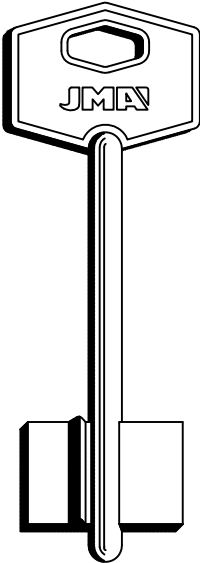
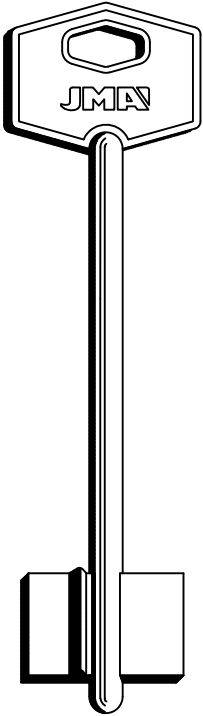
WELKA (I)

| TITANO  |   | TOVER   | 4 TR  |
|---|---|---|---|
|  |  |   |  |
|  |  |  |  |
| TTN-1G  | TTN-2G  | TOV-1G  | TR-1G   |

| TUSHINO   | WELKA   |   |
|---|---|---|
|  |  |  |
|  |  |  |
| TUS-1G  | WE-1G   | WE-2G   |



# YALE

PARA-FOR:

YALE (I)

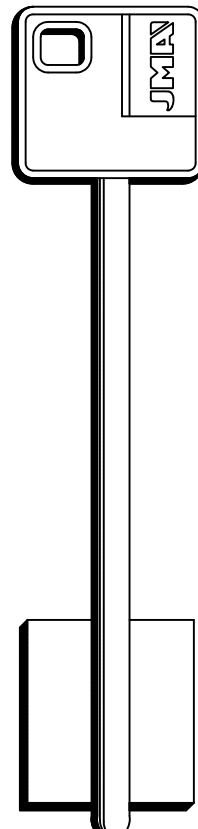
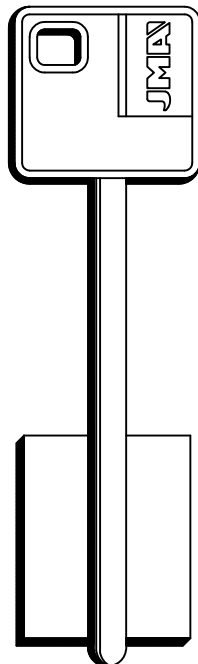
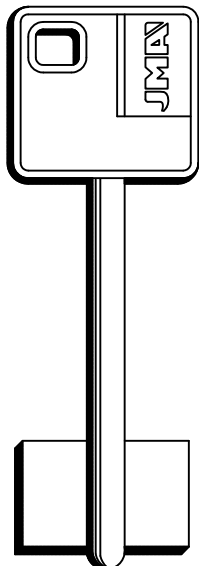
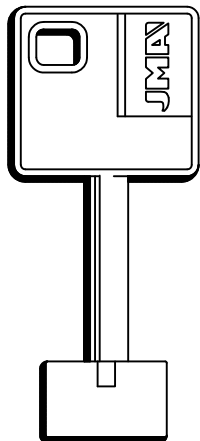

YA-1G



YA-2G



YA-3G



YA-4G



PARA-FOR:

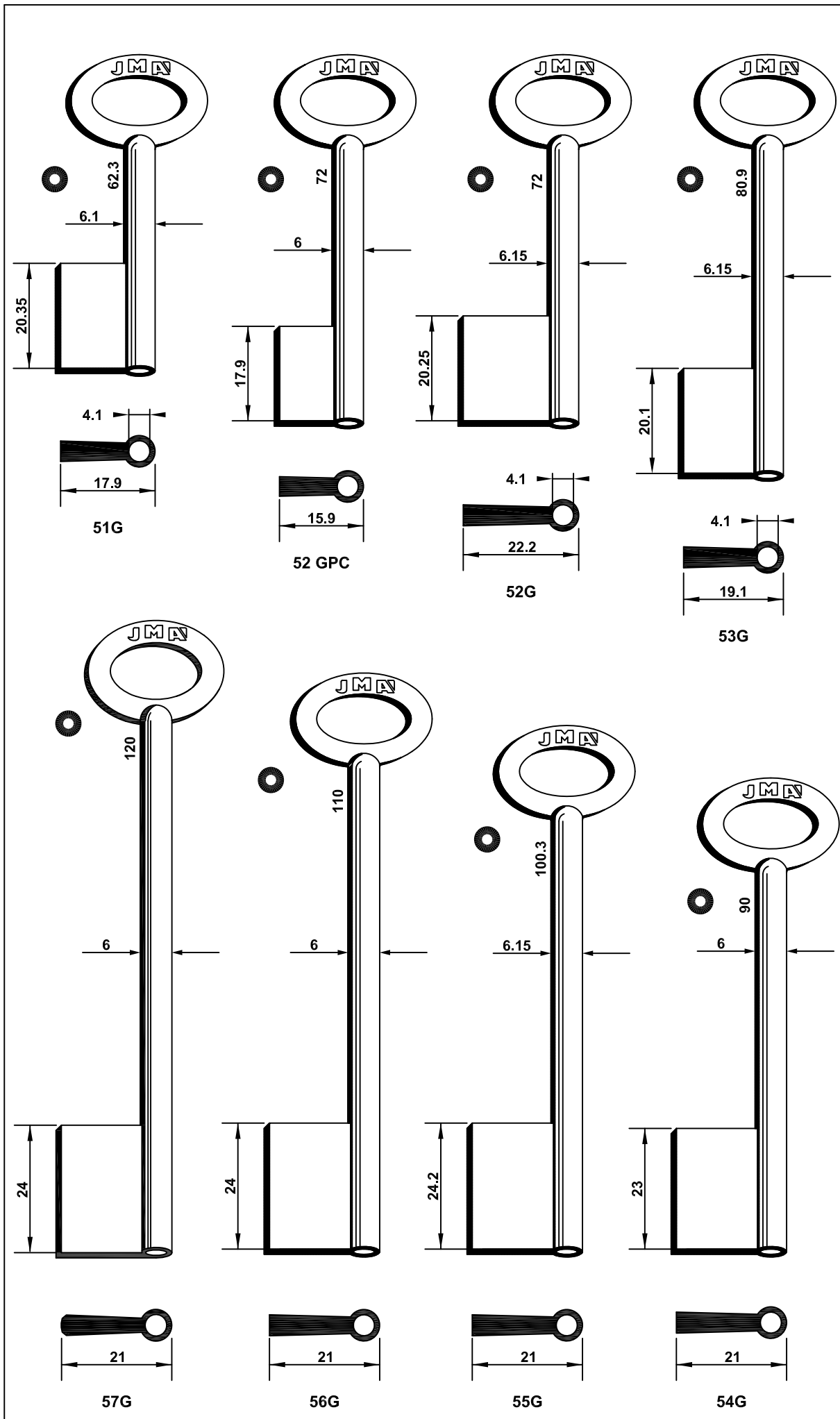



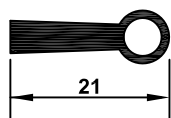
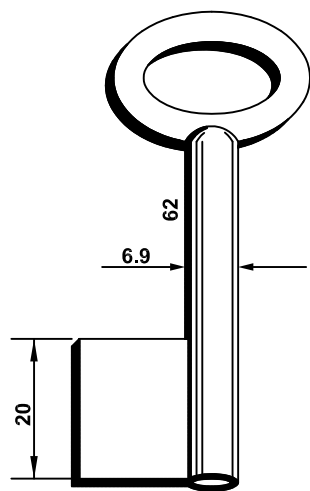

66G

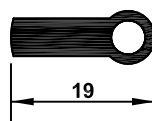
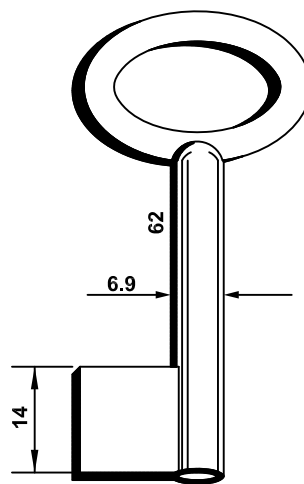

68G

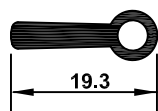
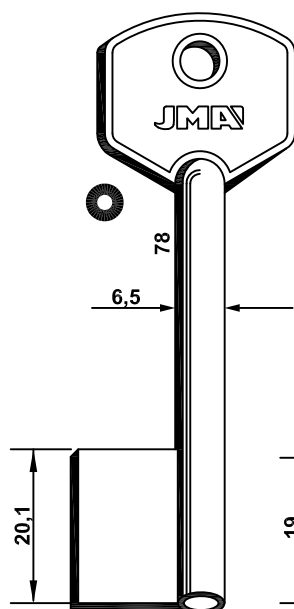

72G

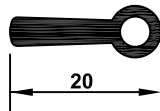
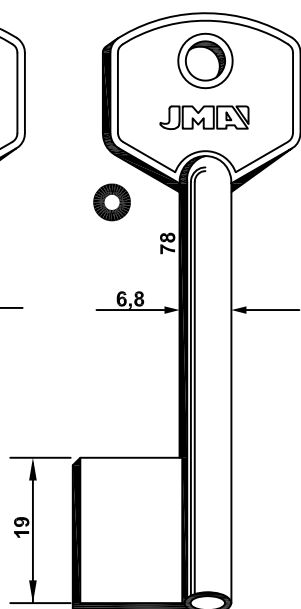

73G



**PARA-FOR:**

- ABUS (D)
- AGA (E)
- ALEDAL (S)
- ARCU (E)

|   |  | ABUS  | AGA   |
|---|--|---|---|
|   | <p>105<br/>5.90<br/>65<br/>21.3<br/>∅4<br/>AD-33T</p>      | <p>ABU-2G</p>   | <p>6.00<br/>62.5 mm<br/>13.5<br/>18.2<br/>∅4,1<br/>AGA-2G</p> |
| AGA   | ALEDAL   | ARCU  |   |
| <p>6.00<br/>65 mm<br/>13.3<br/>17.9<br/>A ∅4,1<br/>AGA-3G<br/>B ∅4,1<br/>AGA-5G</p> | <p>9.4<br/>74 mm.<br/>8.6<br/>15.5<br/>∅7.4<br/>ALE-1G</p> | <p>6.2<br/>59 mm.<br/>12.9<br/>16.1<br/>∅4.1<br/>ARC-1G</p> | <p>6.7<br/>76 mm<br/>18<br/>17.6<br/>∅4.05<br/>ARC-2G</p>     |



## ARCU

PARA-FOR:

ARCU (E)

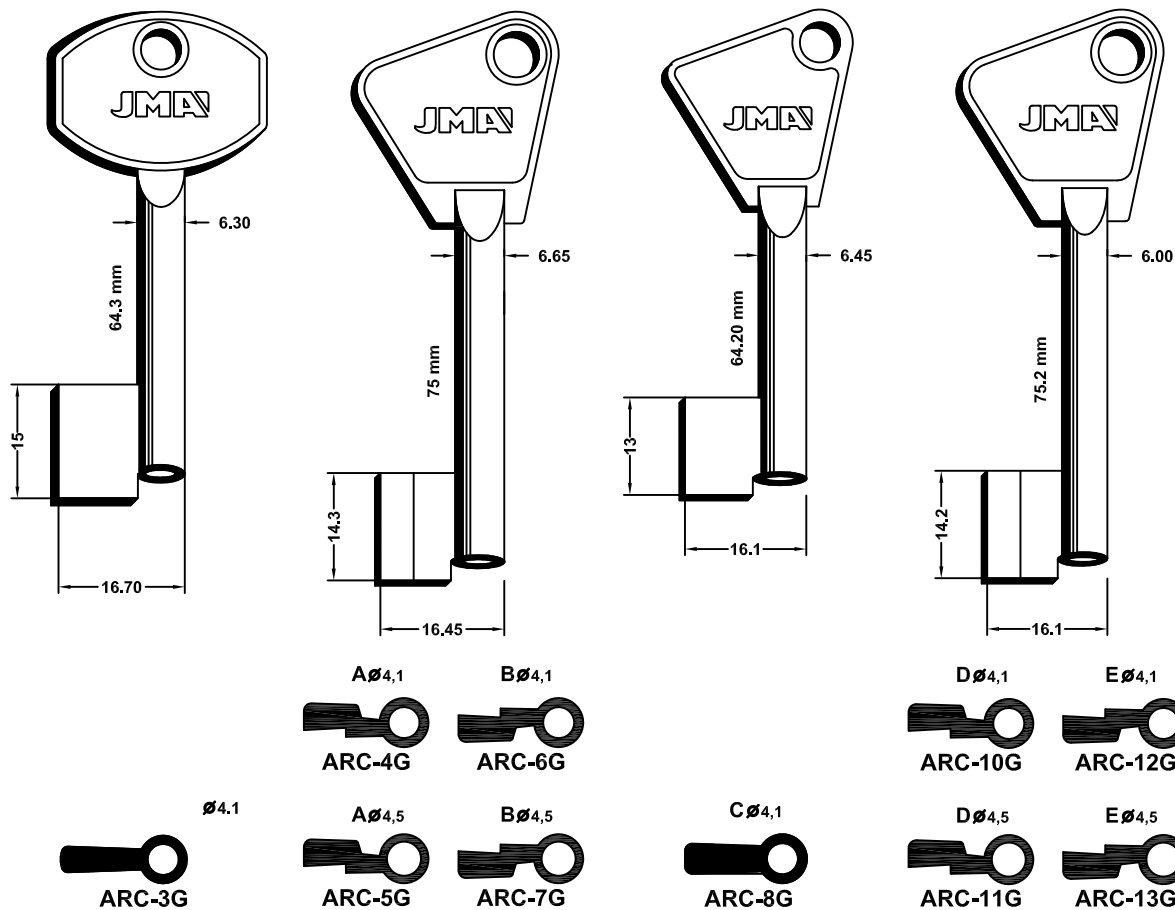

## ARCU

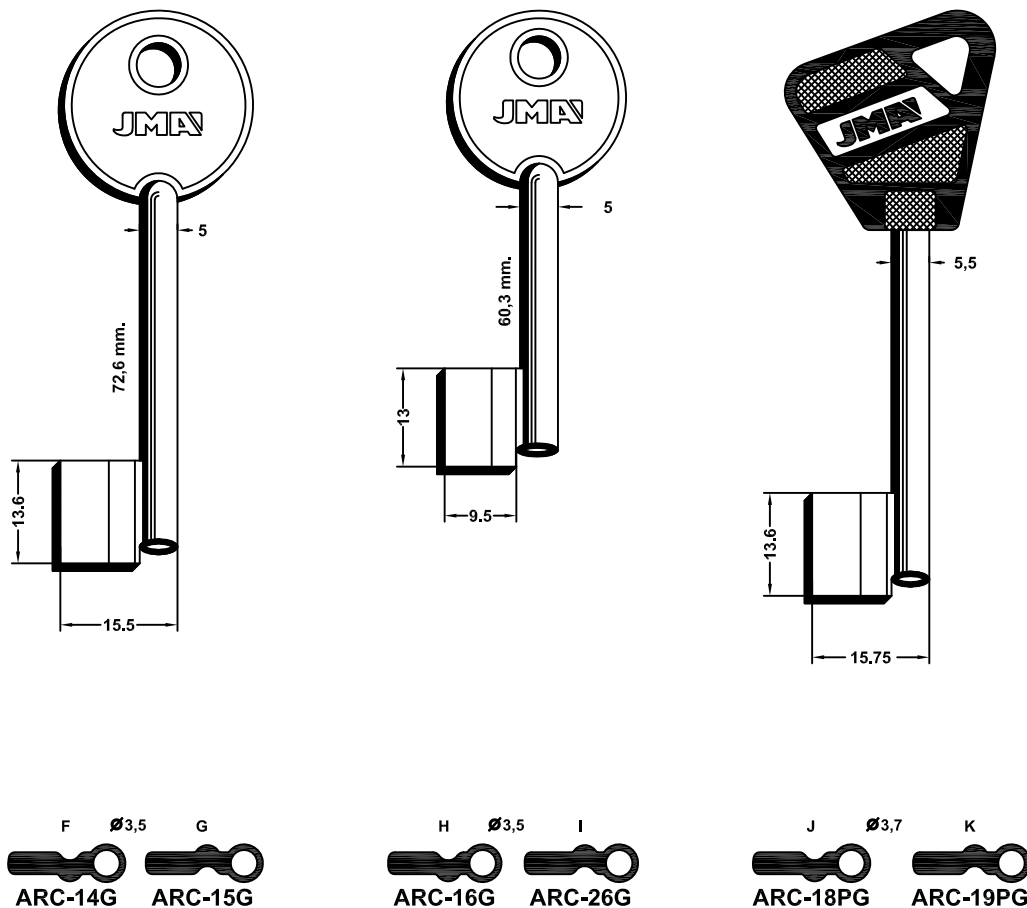

**PARA-FOR:**

- ARCU (E)
- ASSA (S)
- AYPE (E)
- CERUTTI (I)
- LAR (E)

| ARCU |         | ASSA |  |
|------|---------|------|--|
|      |         |      |  |
|      |         |      |  |
|      |         |      |  |
|      |         |      |  |
| AYPE | CERUTTI | LAR  |  |
|      |         |      |  |
|      |         |      |  |



# ORENGO

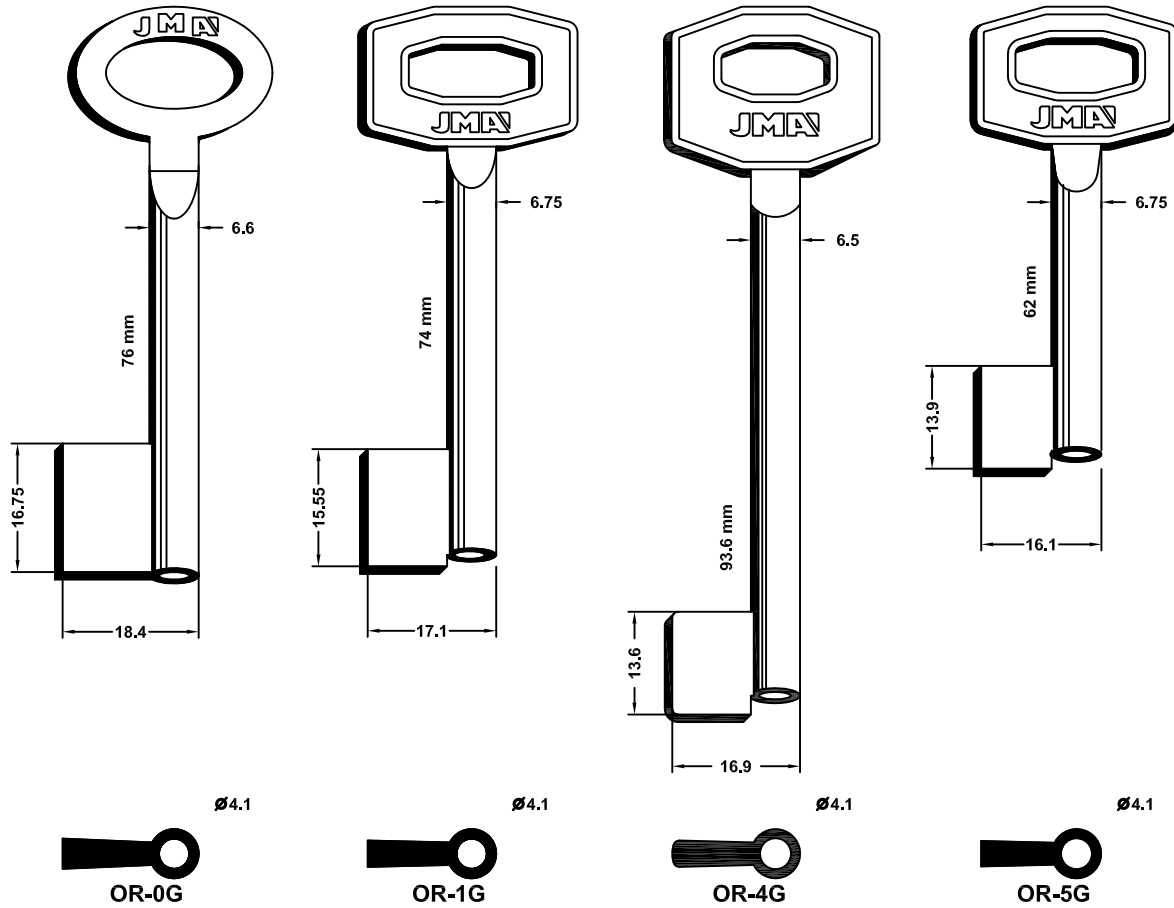

# PARA-FOR:

- ORENGO (E)
- RUBEN (RUS)
- RUE (F)
- VILLFER (E)

## RUBEN

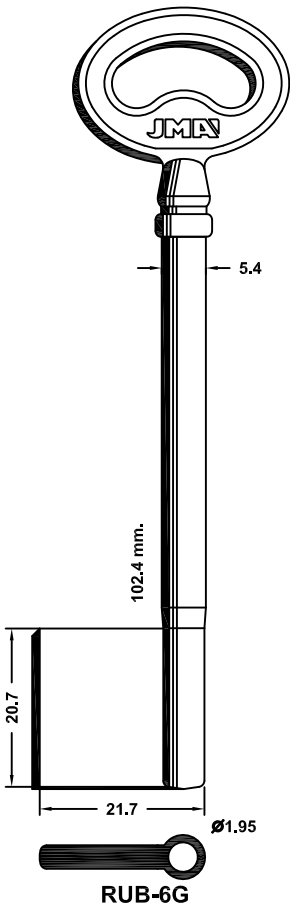

## RUE

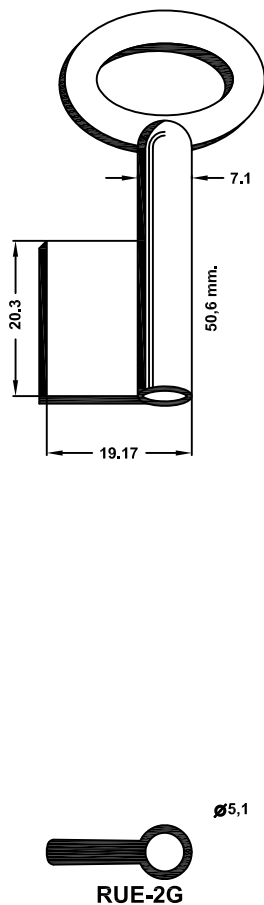

## VILLFER

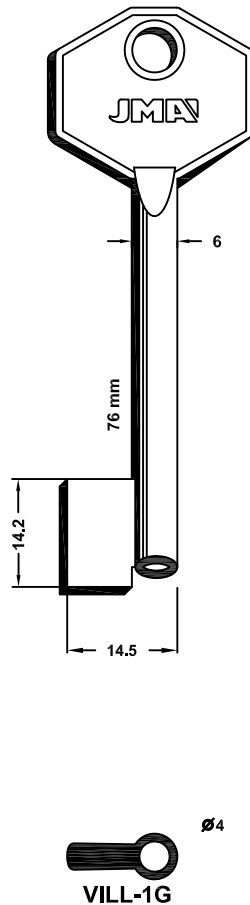

**PARA-FOR:**

AGA (E)

ARES (RUS)

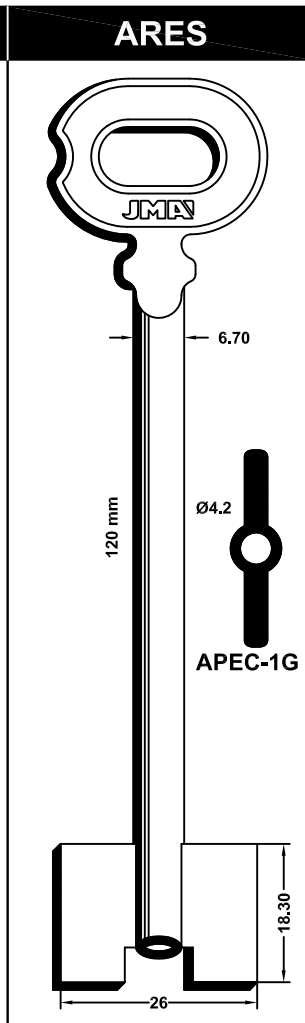
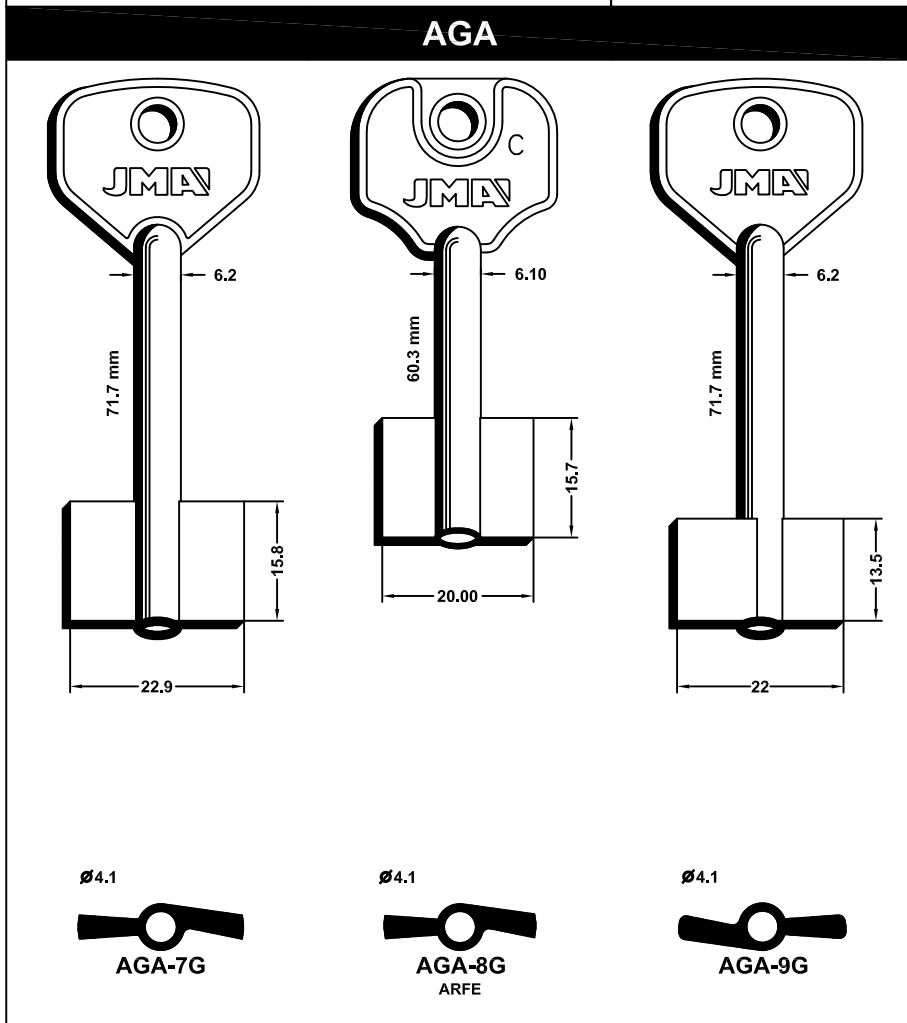
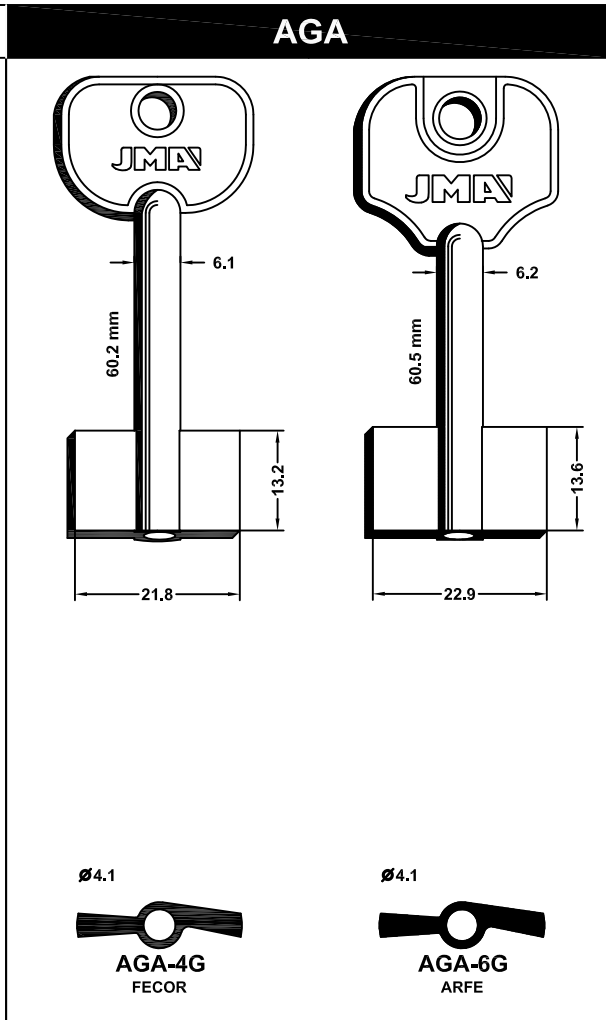
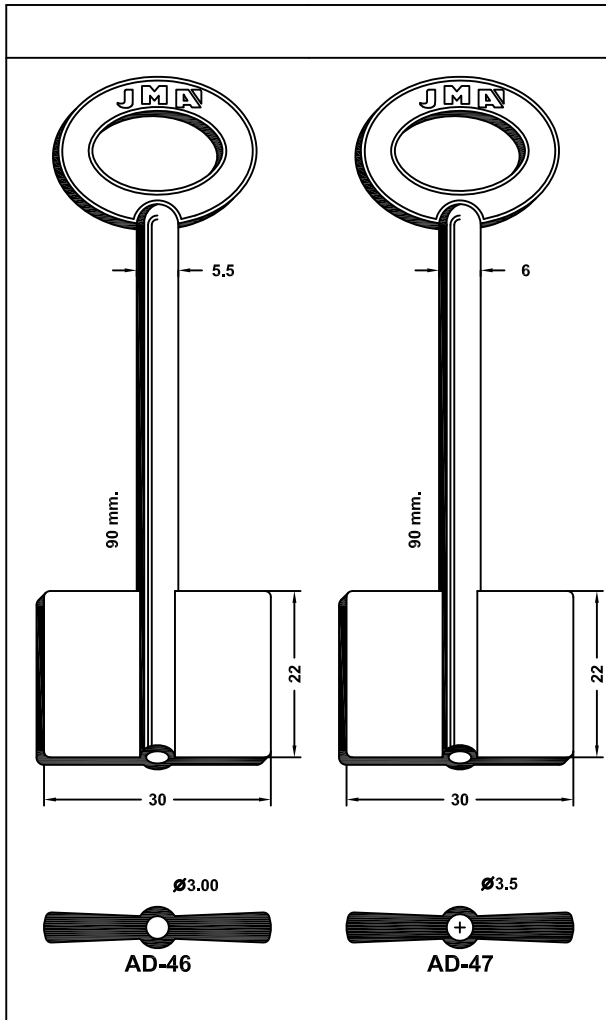

| ARES   | BURG  | CRONOS  | DUPLEX   |
|--|---|---|--|
| <p>78 mm<br/>6.70<br/>18.30<br/>26<br/>Ø4.20<br/>APEC-2G</p> | <p>68 mm.<br/>6.4<br/>16.5<br/>23<br/>Ø4<br/>BUR-1G</p> | <p>68 mm.<br/>6<br/>12<br/>24<br/>Ø4<br/>CRO-1G</p> | <p>75 mm.<br/>6.00<br/>16.00<br/>28.90<br/>Ø3,5<br/>DUP-1G</p> |

**PARA-FOR:**  
 ARES (RUS)  
 BURG (D)  
 CRONOS  
 DUPLEX (RUS)  
 DVERNIAK (RUS)

**DVERNIAK**

|  |  |   |  |
|--|--|---|--|
| <p>120 mm<br/>6.70<br/>18.30<br/>26<br/>Ø4.2<br/>DV-2G</p> | <p>100 mm<br/>6.50<br/>20<br/>32<br/>Ø3.80<br/>Ø3.80<br/>DV-4G</p> | <p>71,2 mm<br/>5.44<br/>17.70<br/>24,60<br/>Ø3.7<br/>DV-10G/A</p> | <p>99,7 mm<br/>6.00<br/>17.70<br/>27.40<br/>Ø3.60<br/>Ø3.60<br/>DV-11G</p> |
|--|--|---|--|



**PARA-FOR:**

DVERNIAK (RUS)

EREVAN (RUS)

MACOR (E)

MAXIM (RUS)

PREFER (I)

RUBEN (RUS)

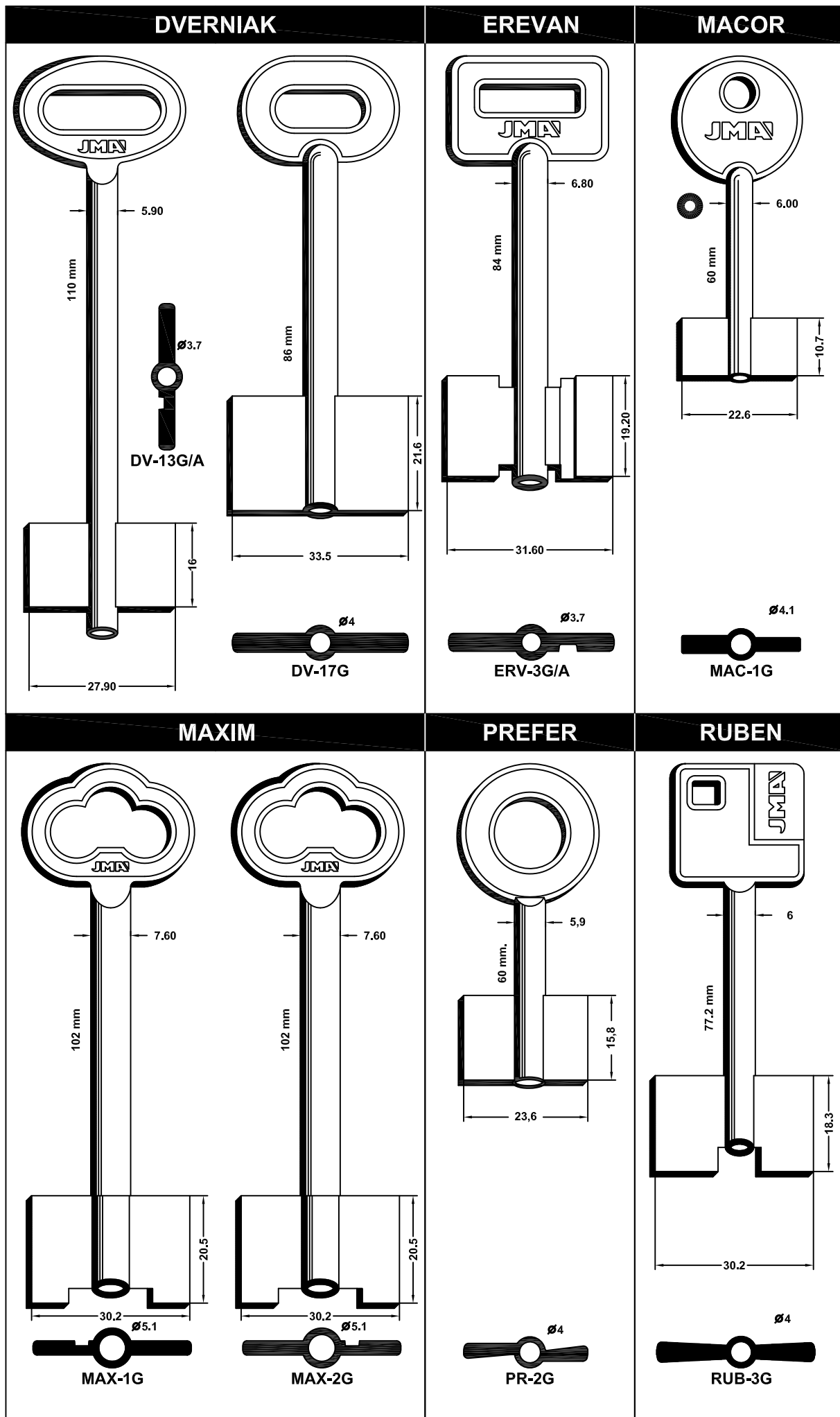

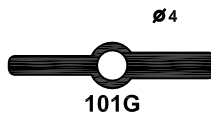
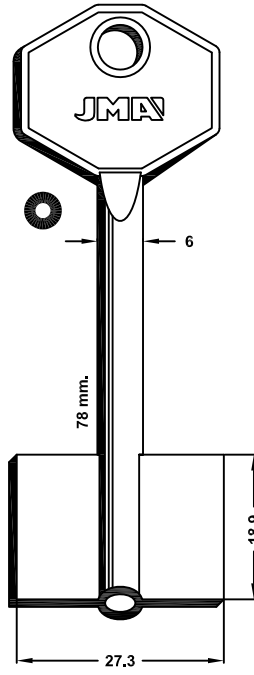
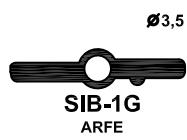
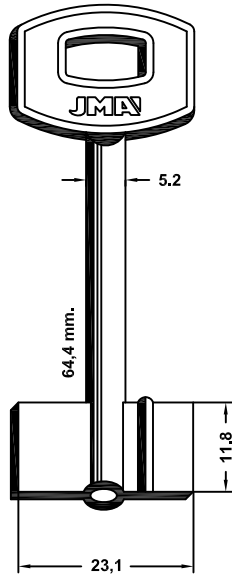
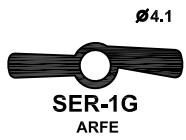
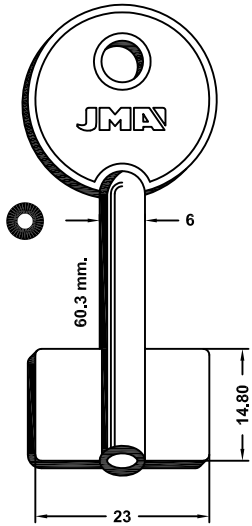

**SERRALLER****SIBI**

**PARA-FOR:**  
SERRALLER (E)  
SIBI (I)



# ***LLAVES DE GORJA ZAMAK***

*ZAMAKEZKO GORJA GILTZAK*

*ZAMAK BIT KEYS*

*CLES A GORGES EN ZAMAK*

*CHUBBSCHLÜSSEL AUS ZAMAK*



***THE KEY TO EXCELLENCE***  
*GLOBALLY UNLOCKING MILLIONS OF DOORS DAILY*

# AGA

PARA-FOR:

AGA (E)

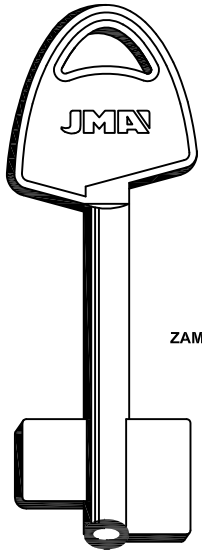

ZAM.

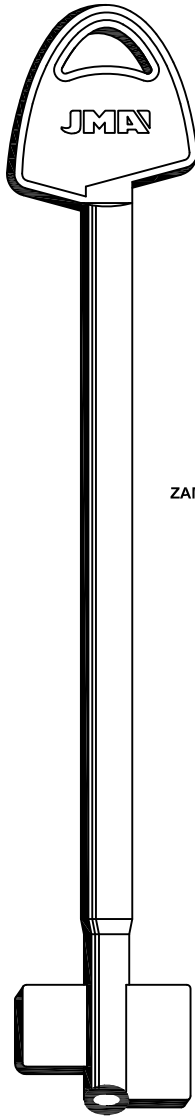

ZAM.

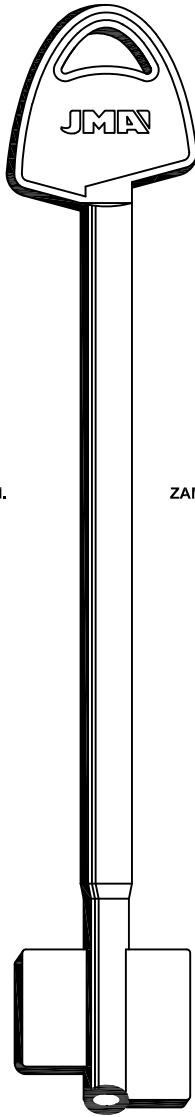

ZAM.

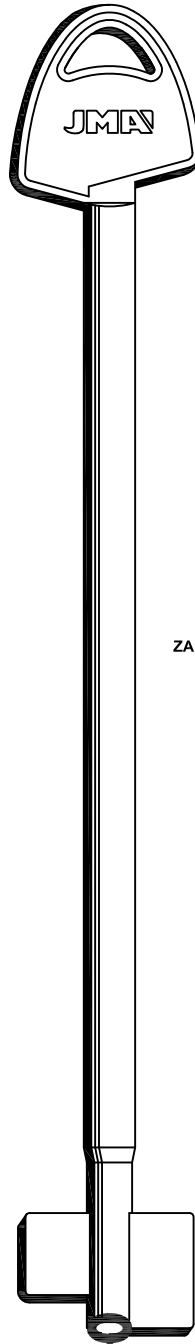

ZAM.

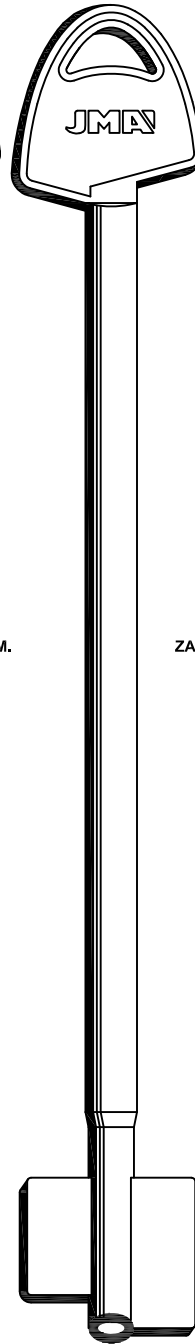

ZAM.



AGA-15G



AGA-23G



AGA-27G



AGA-35G



AGA-40G



**PARA-FOR:**

AGA (E)

CAS CISMA (I)

NEMEF (D)

**AGA**

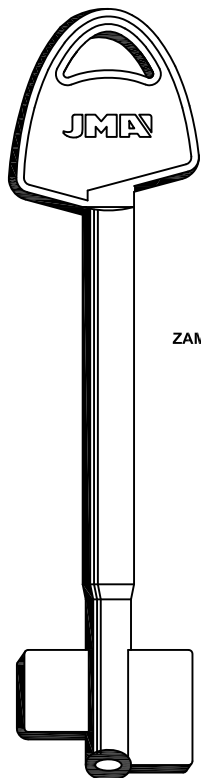

ZAM.



AGA-46G

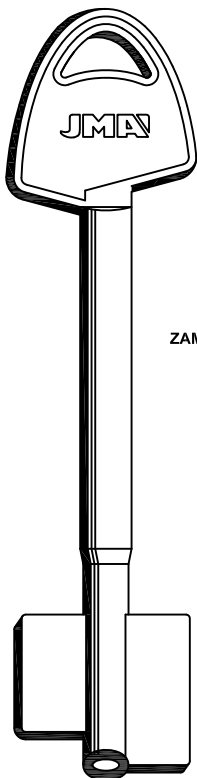

ZAM.



AGA-50G

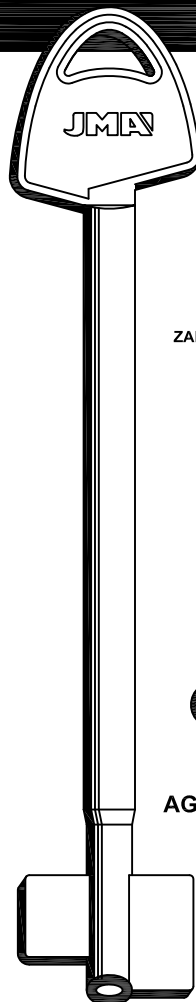

ZAM.

AGA-48G

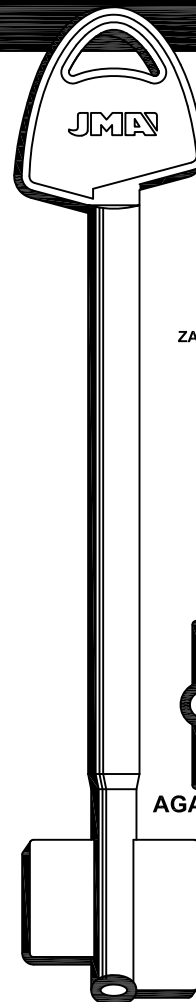

ZAM.

AGA-49G

**CAS CISMA**

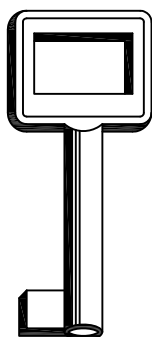

ZAM.



CIS-803/....

**NEMEF**

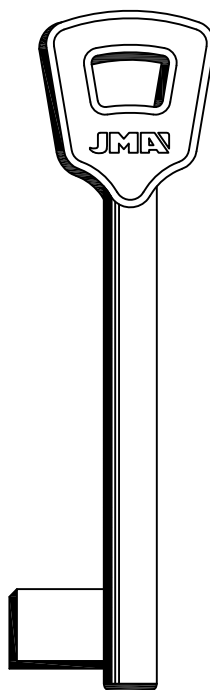

NEF-2Z-..

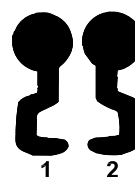

ZAM.

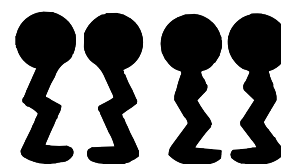
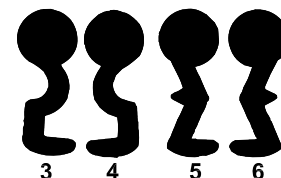

BMH-FH-VACHETTE



# ***LLAVES ARTÍSTICAS Y DE ARMARIO LATÓN***

*LETOIZKO GILTZAK: ARMAIRUETARAKO ETA ARTISTIKOAK*

*BRASS FURNITURE KEYS*

*CLES POUR MEUBLES EN LAITON*

*MOBELSCHLÜSSEL AUS MESSING*



***THE KEY TO EXCELLENCE***  
*GLOBALLY UNLOCKING MILLIONS OF DOORS DAILY*

PARA-FOR:

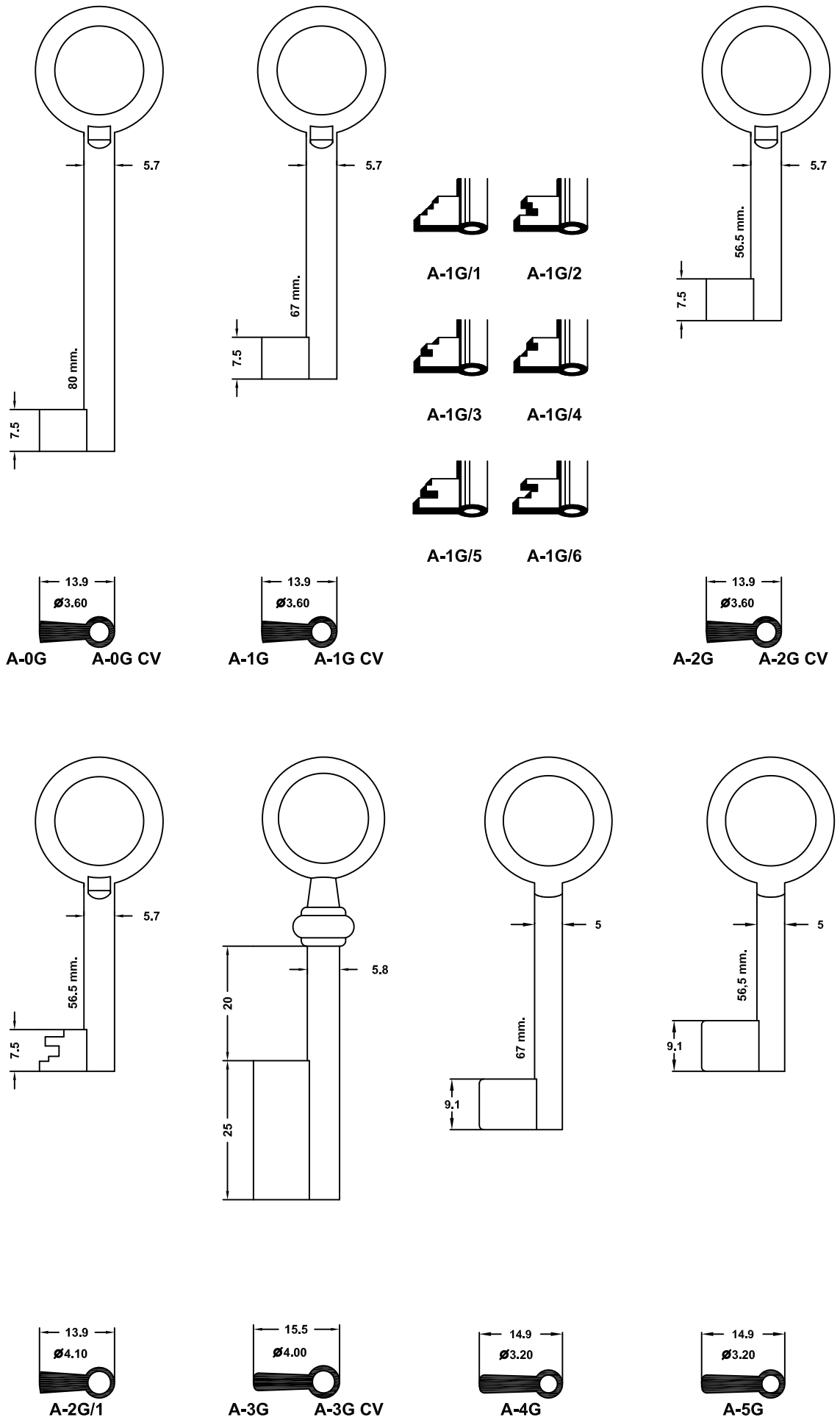

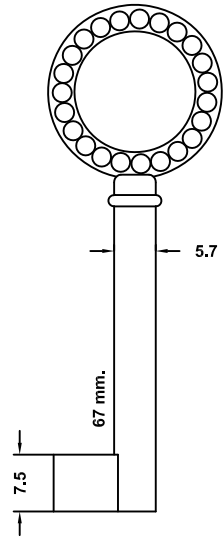

AA-1G AA-1G CV

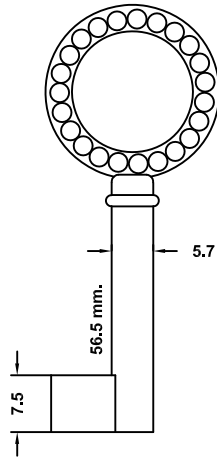

AA-2G AA-2G CV

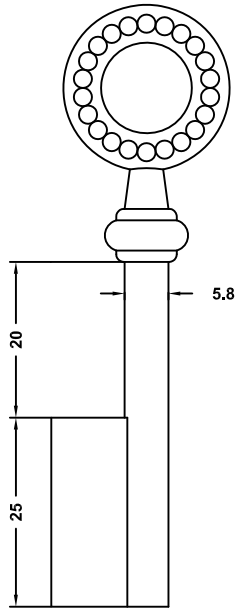

AA-3G AA-3G CV

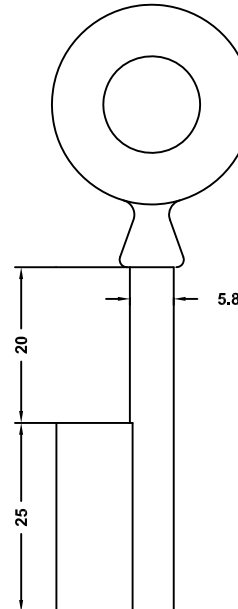

B-3G B-3G CV

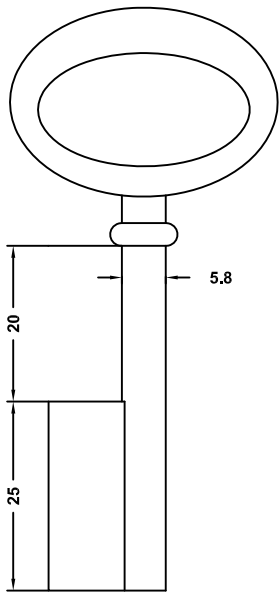
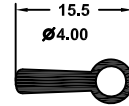
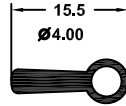
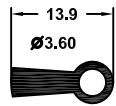

C-3G C-3G CV

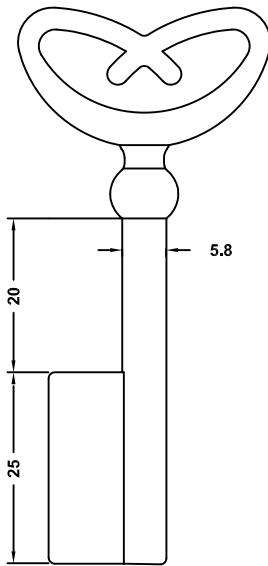

D-3G D-3G CV

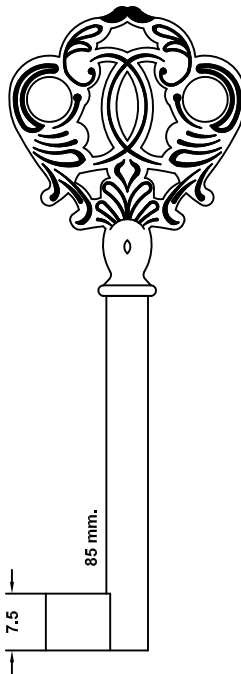

E-0G E-0G CV

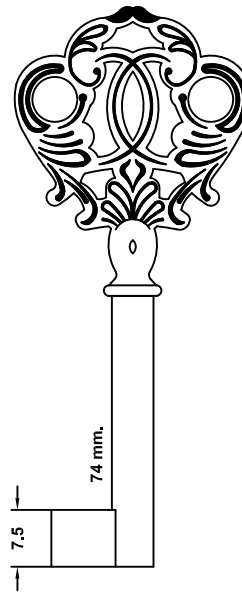

E-1G E-1G CV

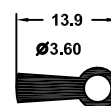
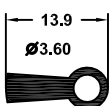
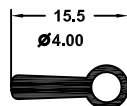
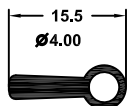

PARA-FOR:

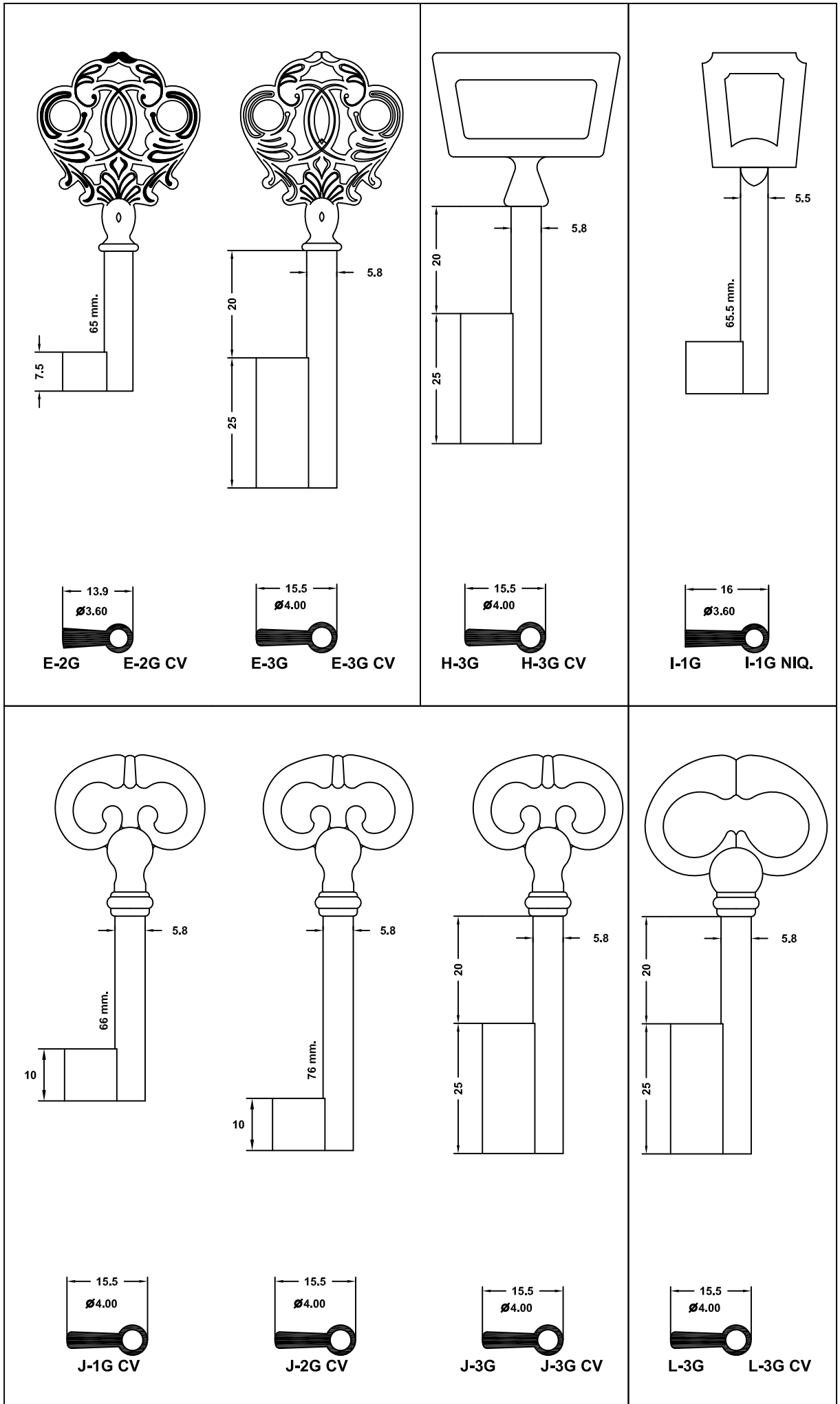



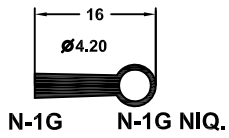
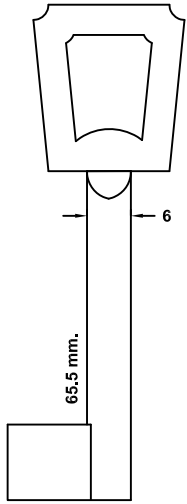

N-1G N-1G NIQ.

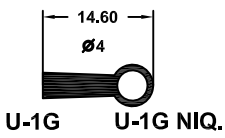
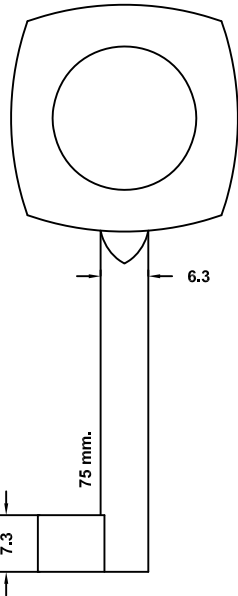

U-1G U-1G NIQ.

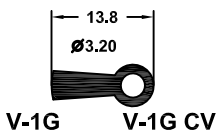
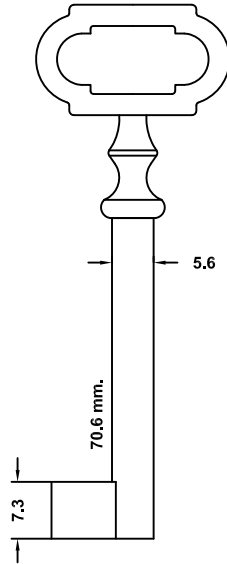

V-1G V-1G CV

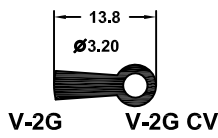
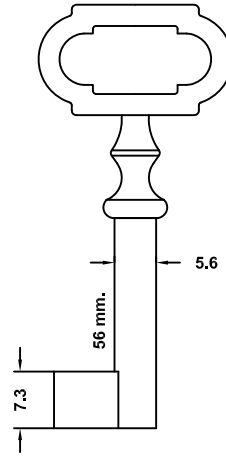

V-2G V-2G CV

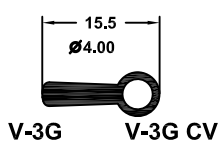
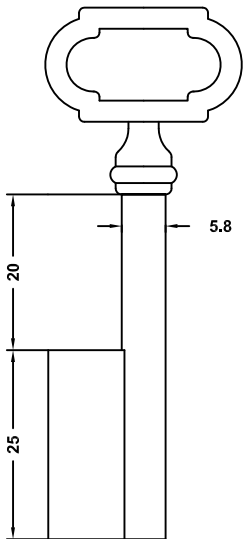

V-3G V-3G CV

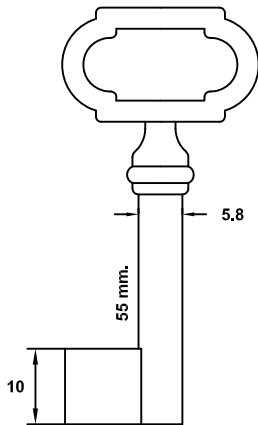

V-4G CV

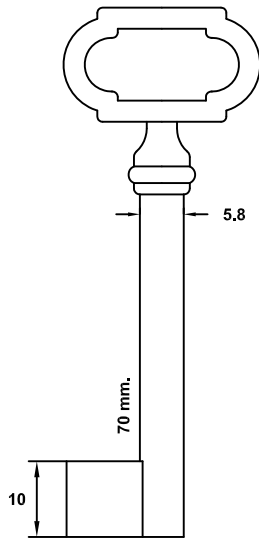

V-5G CV



# ***LLAVES ARTÍSTICAS Y DE ARMARIO ZAMAK***

*ZAMAKEZKO GILTZAK: ARMAIRUETARAKO ETA ARTISTIKOAK*

*ZAMAK FURNITURE KEYS*

*CLES POUR MEUBLES EN ZAMAK*

*MOBELSCHLÜSSEL AUS ZAMAK*



***THE KEY TO EXCELLENCE***  
*GLOBALLY UNLOCKING MILLIONS OF DOORS DAILY*

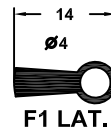
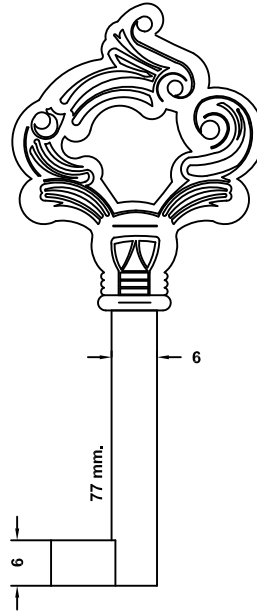
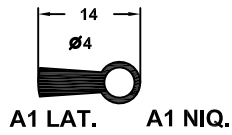
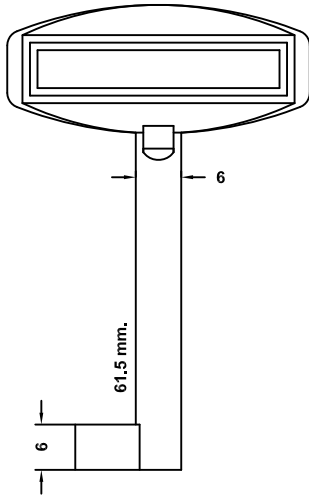

# ***LLAVES PARA CASILLAS Y ASCENSORES***

*KUTXATILA ETA IGOGAILUENTZAKO GILTZAK*

*LIFT AND MAIL BOX KEYS*

*CLES POUR ASCENSEURS ET BOITES A LETTRES*

*FACHKASTEN-UND LIFTSSCHLÜSSEL*

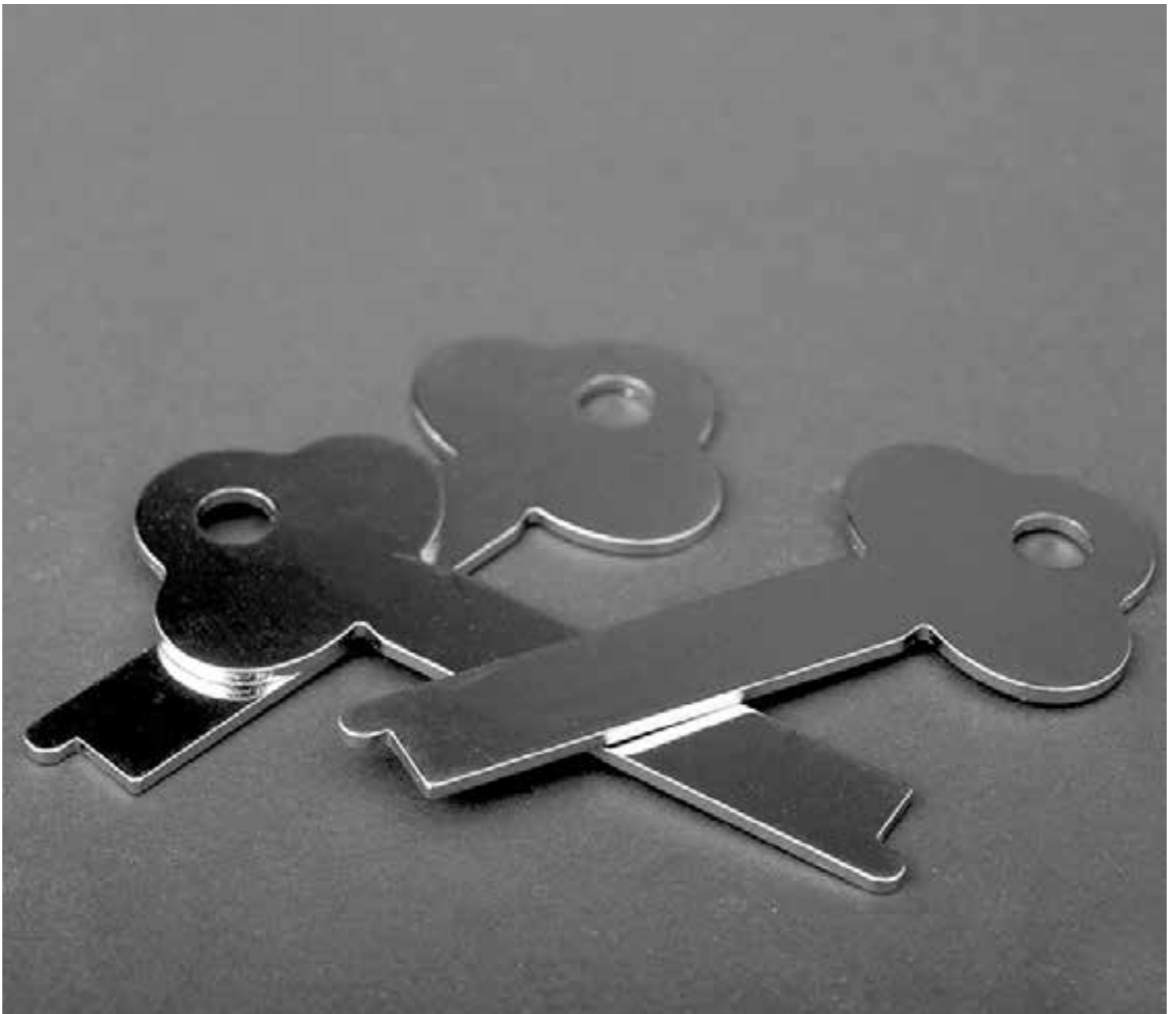

***THE KEY TO EXCELLENCE***

*GLOBALLY UNLOCKING MILLIONS OF DOORS DAILY*

**PARA-FOR:**

DIEBOLD (D)

RIL (E)

SERRETA (E)

URKO (E)

YALE (D-GB)

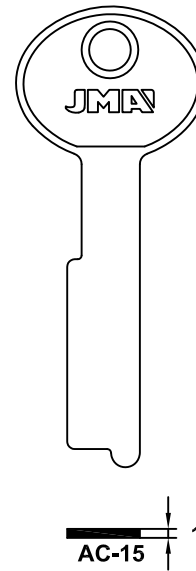
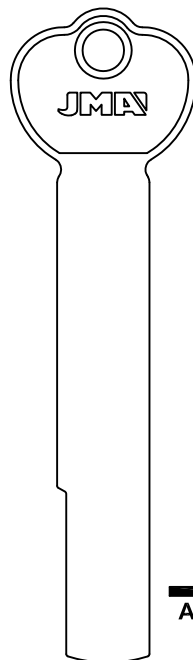
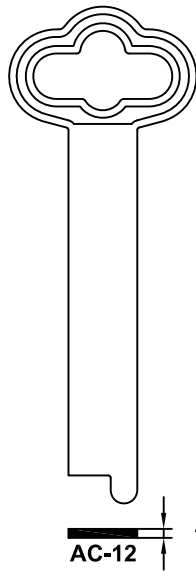
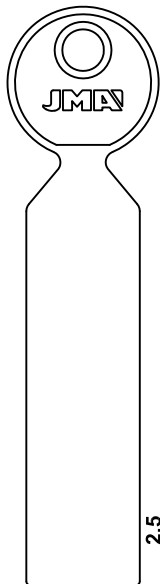

**DIEBOLD**

**RIL**

**SERRETA**

**URKO**

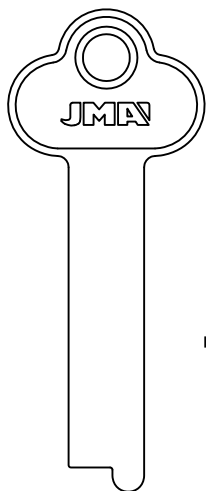

LAT.

**DIE-1**

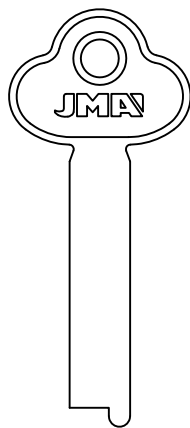

**26-M**

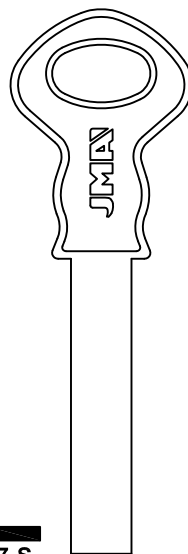

**7-S**

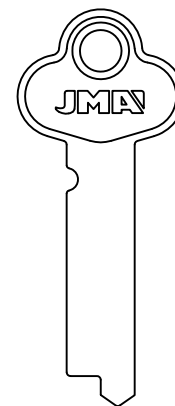

**URKO-4**

**YALE**

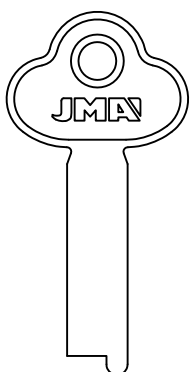

LAT.

**YA-30**





# **AUTOMÓVIL - CAMIONETA**

*AUTOMOBILA-KAMIONETA*

*CAR-PICK UP TRUCK*

*VOITURE-CAMIONNETTE*

*AUTO-KLEINTRANSPORTER*

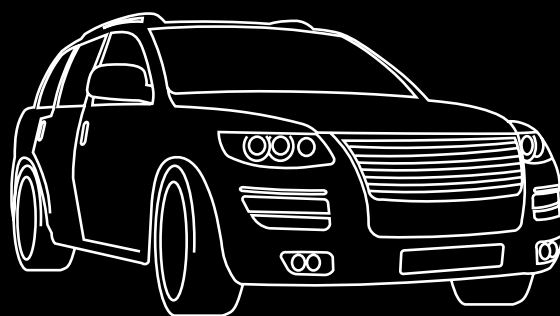

**THE KEY TO EXCELLENCE**  
GLOBALLY UNLOCKING MILLIONS OF DOORS DAILY











# AUTOMÓVIL - CAMIONETA



## CAR - PICK-UP TRUCKS



### AUTOMÓVIL-CAMIONETA

AUTOMOVILA-KAMIONETA • CAR-PICK-UP TRUCKS  
VOITURE-CAMIONNETTE • AUTO-KLEINTRANSPORTER

| MARCA BRAND   | MODELO MODEL |  |  |  |
|---------------|--------------|---|---|---|
| ABT           | GOLF 3       | 1991-   | AU-AH   | AU-AH   |
|               |              |   | AU-AHP  | AU-AHP  |
|               |              |   | VO-2  | VO-2  |
|               |              |   | VO-2P   | VO-2P   |
| ACM           | 10.1 ENDURO  | -   | NE-15I  | RO-15   |
|               | 10.4 ENDURO  | -   | NE-15IP   |   |
|               | OFF 4WD      | -   |   |   |
| ACURA (HONDA) | INTEGRA      | -1989   | HOND-10   | HOND-10   |
|               | LEGEND       | 1989-1991   | HOND-10P  | HOND-10P  |
|               | MODELOS      | 1986-1988   |   |   |
|               | INTEGRA      | 1990-   | HOND-15   | HOND-15   |
|               | VIGOR        | 1992-   | HOND-15P  | HOND-15P  |
|               | LEGEND       | 1991-   | HOND-17P  | HOND-17P  |
|               | NSX          | 1991-1997   | HOND-16D<br>HOND-16DP<br>HOND-16DP1   | HOND-16D<br>HOND-16DP<br>HOND-16DP1   |
| AIXAM         | 500-4        | -   | SIX-3P  | SIX-3P  |
|               | COUPE        | 2008  |   |   |
|               | CROSSLINE    | 2007  |   |   |
|               | CROSSOVER    | 2011  |   |   |
|               | GTO          | 2011  |   |   |
|               | ROADLINE     | 2009-2010   |   |   |
|               | SCOUTY       | 2005-2012   |   |   |
| ALFA ROMEO    | 10 AR 6      | -   | FI-12   | FI-12   |
|               | 13 AR 6      | -   | FI-12P  | FI-12P  |
|               |              |   | FI-12P3   | FI-12P3   |
|               |              |   | FI-3D   | FI-3D   |
|               |              |   | FI-3DP3   | FI-3DP3   |
|               |              |   | FI-6I   | FI-6I   |
|               | 30 AR 8      | -1986   | AF-7I   | IMS-3   |
|               | 35 AR 8      | -1986   | AF-7IP  | IMS-3P  |
|               | 40 AR 8      | -1986   | FI-9I   | IMS-5   |
|               |              |   | FI-9IP  | IMS-5P  |
|               | 30 AR 8      | 1986-   | FI-2D   | FI-2D   |
|               | 35 AR 8      | 1986-   | FI-2DP3   | FI-2DP3   |
|               | 40 AR 8      | 1986-   | FI-3D   | FI-3D   |
|               |              |   | FI-3DP1   | FI-3DP1   |
|               |              |   | FI-6I   | FI-6I   |
|               |              |   | FI-6IP1   | FI-6IP1   |
|               | 33           | 1983-1986   | AF-14   | AF-14   |
|               | 164          | 1987-1995   | AF-14P  | AF-14P  |
|               | 164 V6       | 1987-1995   | FI-6I   | FI-6I   |
|               |              |   | FI-6IP4   | FI-6IP4   |
|               | 33           | 1986-1990   | FI-3D   | FI-3D   |
|               | 75 TD        | 1987-   | FI-3DP4   | FI-3DP4   |
|               | 33           | 1990-   | AF-14   | AF-14   |
| 75            | 1990-1991    | AF-14P  | AF-14P  |   |



| MARCA BRAND   | MODELO MODEL  |  |  |  |  |
|---------------|---------------|---|---|---|--|
| ALFA ROMEO    | SZ COUPE      | 1991-   |   |   |  |
|               | 75 MILANO     | 1985-   | AF-13   | AF-13   |  |
|               | 90            | 1985-   | AF-13P  | AF-13P  |  |
|               | SPIDER        | 1991-1995   |   |   |  |
|               |               |   |   |   |  |
|               | 90            | 1984-1985   | FI-6I   | FI-6I   |  |
|               | 145           | 1994  | FI-6IP4   | FI-6IP4   |  |
|               |               |   | FI-13   | FI-13   |  |
|               | 155           | 1992-1995   | FI-13P  | FI-13P  |  |
|               |               |   | FI-14P  | FI-14P  |  |
|               | 155 6V        | 1992-1995   | FI-13P  | FI-13P  |  |
|               | 155 T.S.      | 1992-1995   | FI-14P  | FI-14P  |  |
|               | 1750          | -   | AF-7I   | AF-5D   |  |
|               | GIULIA 1600   | -   | AF-7IP  | AF-5I   |  |
|               |               |   | NE-25   | AF-6D<br>AF-6I  |  |
|               | 2000 BERLINA  | -   | AF-7I   | AF-5D   |  |
|               | A 11 D        | -   | AF-7IP  | AF-5I   |  |
|               | A 12 D        | -   |   | AF-6D   |  |
|               | ALFETTA 1.6 1 | -   |   | AF-6I   |  |
|               | ALFETTA 1.8 1 | -   |   |   |  |
|               | F 11 D        | -   |   |   |  |
|               | F 12 D        | -   |   |   |  |
|               | GIULIA DIES.  | -   |   |   |  |
| SPRINT        | -             |   |   |   |  |
| 2000 COUPE    | -             | SIP-3   | AF-5D   |   |  |
| 2000 SPIDER   | -             |   | AF-5I<br>AF-6D<br>AF-6I   |   |  |
| A 11          | -             | BH-8  | AF-5D   |   |  |
| A 12          | -             |   | AF-5I   |   |  |
| F 11          | -             |   | AF-6D   |   |  |
| F 12          | -             |   | AF-6I   |   |  |
| A 20          | -             | BH-1  | RO-7D   |   |  |
| A 38          | -             | BH-1P   |   |   |  |
| ALFA 6        | 1984-         | FI-6I   | AF-10   |   |  |
| ALFETTA       | 1982-1984     | FI-6IP4   | AF-11<br>AF-12  |   |  |
| ALFASUD       | -             | AF-7I   | AF-5D   |   |  |
|               |               | AF-7IP  | AF-5I   |   |  |
|               |               | FI-6I   | AF-6D   |   |  |
|               |               | FI-6IP4   | AF-6I   |   |  |
|               |               | FI-9I   |   |   |  |
|               |               | FI-9IP  |   |   |  |
|               |               | SIP-3   |   |   |  |
| ALFETTA       | 1978-1982     | AF-7I   | AF-10   |   |  |
| ALFETTA 1.6 2 | -             | AF-7IP  | AF-11   |   |  |
| ALFETTA 1.6 G | -             |   | AF-12   |   |  |



| MARCA BRAND     | MODELO MODEL  |  |  |  |
|-----------------|---------------|---|---|---|
| ALFA ROMEO      | ALFETTA 1.8 2 | -   |   |   |
|                 | ALFETTA 1.8 G | -   |   |   |
|                 | ALFETTA 2.0 G | -   |   |   |
|                 | GIULIETTA     | 1979-1981   |   |   |
|                 | ALFETTA       | 1984-   | FI-6I   | AF-10   |
|                 |               |   | FI-6IP4   | AF-11   |
|                 |               |   |   | AF-12   |
|                 |               |   |   | FI-6I   |
|                 |               |   |   | FI-6IP4   |
|                 | ARNA 1.2 L    | -   | FI-6I   | DAT-6   |
|                 | ARNA 1.2 LS   | -   | FI-6IP4   | DAT-6P  |
|                 | ARNA 1.3 TI   | -   |   |   |
|                 | DUETTO        | -   | FI-6I   | AF-5D   |
|                 |               |   | FI-6IP4   | AF-5I   |
|                 |               |   |   | AF-6D   |
|                 |               |   |   | AF-6I   |
|                 | GIULIA 1300   | -   | AF-7I   | AF-5D   |
|                 |               |   | AF-7IP  | AF-5I   |
|                 |               |   | BH-8  | AF-6D   |
|                 |               |   | NE-25   | AF-6I   |
|                 | GIULIETTA     | 1981-   | FI-6I   | GIOB-3P   |
|                 | GTV 2.0       | 1982-1995   | FI-6IP4   |   |
|                 | GTV 2.0 6V    | 1984-1995   |   |   |
|                 | GTV 2.5       | 1982-1995   |   |   |
| GTV 2.5 6V      | 1984-1995     |   |   |   |
| MONTREAL        | -             | AF-7I   | IMS-3   |   |
|                 |               | AF-7IP  | IMS-3P  |   |
|                 |               |   | IMS-5   |   |
|                 |               |   | IMS-5P  |   |
| SPIDER          | 1970-1989     | AF-7I   | AF-5D   |   |
|                 |               | AF-7IP  | AF-5I   |   |
|                 |               | FI-6I   | AF-6D   |   |
|                 |               | FI-6IP4   | AF-6I   |   |
|                 |               | SIP-3   |   |   |
| SPIDER          | 1990-1991     | AF-14   | AF-5D   |   |
|                 |               | AF-14P  | AF-5I   |   |
|                 |               |   | AF-6D   |   |
|                 |               |   | AF-6I   |   |
| SPIDER 1300     | -             | AF-7I   | AF-5D   |   |
|                 |               | AF-7IP  | AF-5I   |   |
|                 |               | BH-8  | AF-6D   |   |
|                 |               |   | AF-6I   |   |
| AMERICAN MOTORS | ALLIANCE      | 1981-1983   | CHR-3   | NE-16   |
|                 | ENCORE        | 1981-1983   | CHR-3P  | NE-59P  |
|                 |               |   |   | VA-10   |
|                 | ALLIANCE      | 1984-1985   | CHR-3   | NE-16   |
|                 | ENCORE        | 1984-1985   | NE-19   | NE-59P  |
|                 |               |   | NE-19P  | VA-10   |
|                 |               |   | NE-22P  |   |
|                 | ALLIANCE      | 1985-1986   | CHR-3   | BAS-1I  |
|                 | ENCORE        | 1985-1986   | NE-22P  |   |
|                 | ALLIANCE      | 1986-1988   | NE-19   | BAS-1I  |
| ENCORE          | 1986-1988     | NE-19P  |   |   |



| MARCA BRAND     | MODELO MODEL  |  |  |  |      |
|-----------------|---------------|---|---|---|------|
| AMERICAN MOTORS | CHEROKEE      | -1990   | BAS-1I  | BAS-1I  |      |
|                 | COMANCHE      | -1990   | GM-9  |   |      |
|                 | W.BASE        | -1990   | GM-9P   |   |      |
|                 | W.ISLANDER    | -1990   | GM-J  |   |      |
|                 | W.LAREDO      | -1990   | GM-JP   |   |      |
|                 | W.SAHARA      | -1990   |   |   |      |
|                 | W.TEXAS       | -1990   |   |   |      |
|                 | WAGONEER      | -1990   |   |   |      |
|                 | CHEROKEE      | 1991-1992   | CHR-9   | CHR-9   |      |
|                 | COMANCHE      | 1991-1992   | CHR-9P  | CHR-9P  |      |
|                 | MJ COMANCHE   | 1993-   | CHR-10  | CHR-10  |      |
|                 | XJ CHEROKEE   | 1993-   | CHR-10P   | CHR-10P   |      |
|                 | YJ WRANGLER   | 1993-   |   |   |      |
|                 | ZJ G.CHEROKEE | 1993-   |   |   |      |
|                 | MODELOS       | 1953-1969   | BS-1I   | BS-1I   |      |
|                 | MODELOS       | 1970-1985   | BAS-1I  | BAS-1I  |      |
|                 | WAGONEER      | 1991-1992   | CHR-9   | BAS-1I  |      |
|                 |               |   | CHR-9P  | CHR-9   |      |
|                 |               |   | GM-9  | CHR-9P  |      |
|                 |               |   | GM-9P   |   |      |
|                 |               |   | GM-J  |   |      |
|                 |               |   | GM-JP   |   |      |
|                 | ARO DACIA     | 203   | -   | BH-1  | HU-1 |
|                 |               |   |   | BH-1P   |      |
| 240             |               | 1982-1985   | BH-1  | RO-15   |      |
|                 |               |   | BH-1P   |   |      |
| 240             |               | 1985-   | NE-15I  | RO-15   |      |
| 241             |               | 1985-   | NE-15IP1  |   |      |
| 242             |               | 1985-   |   |   |      |
| 243             |               | 1985-   |   |   |      |
| 244             |               | 1985-   |   |   |      |
| ISCHIA 10.1     |               | 1985-   |   |   |      |
| ISCHIA 10.4     |               | 1985-   |   |   |      |
| SUPER ISCHIA    |               | 1985-   |   |   |      |
| ASTON MARTIN    | LAGONDA       | -   | FO-E-TC   | FO-E-TC   |      |
|                 | LAGONDA LIM.  | -   | FO-E-TCP  | FO-E-TCP  |      |
|                 | V8 SALOON     | -   | FO-FR   | IN-1  |      |
|                 | V8 VANTAGE    | -   | FO-FRP  | OP-WHP  |      |
|                 | V8 VANTAGE Z  | -   | OP-WHP  | OP-WYP  |      |
|                 | V8 VOLANTE    | -   | OP-WYP  | UN-FP   |      |
|                 | V8 VOLANTE C  | -   |   | UN-FS   |      |
|                 |               |   | UN-FT   |   |      |
| AUDI            | 50 GL         | 1974-   | VO-VB   | VO-VB   |      |
|                 | 50 LS         | 1974-   | VO-VBP  | VO-VBP  |      |
|                 | 80 GLS        | 1979  |   |   |      |
|                 | 80 GT         | 1979  |   |   |      |
|                 | 60            | -   |   |   |      |
|                 | 100           | 1973-1977   |   |   |      |
|                 | 100 L         | 1973-1977   |   |   |      |
|                 | 100 LS        | 1973-1977   |   |   |      |
|                 | 80            | 1978-1982   | AU-1  | AU-1  |      |
|                 | 100           | 1978-1982   | AU-HV   | AU-HV   |      |
|                 | 200           | 1978-1982   | AU-HVP  | AU-HVP  |      |
| 4000            | 1978-1982     | VO-VB   | VO-VB   |   |      |



# AUTOMÓVIL - CAMIONETA

## CAR - PICK-UP TRUCKS

| MARCA BRAND | MODELO MODEL |  |  |  |
|-------------|--------------|---|---|---|
| AUDI        | 5000         | 1978-1982   | VO-VBP  | VO-VBP  |
|             | 80           | 1983-1984   | AU-1  | AU-1  |
|             |              |   | AU-HV   | AU-HV   |
|             |              |   | AU-HVP1   | AU-HVP1   |
|             |              |   | VO-HV   | VO-HV   |
|             |              |   | VO-VB   | VO-VB   |
|             |              |   | VO-VBP  | VO-VBP  |
|             | 80           | 1984-1985   | AU-AH   | AU-AH   |
|             | QUATTRO      | 1984-1985   | AU-AHP1   | AU-AHP1   |
|             |              |   | AU-AN   | AU-AN   |
|             |              |   | AU-ANP  | AU-ANP  |
|             |              |   | VO-2  | VO-2  |
|             |              |   | VO-2P   | VO-2P   |
|             | 80           | 1985-   | AU-AH   | AU-AH   |
|             | 90           | 1985-   | AU-AHP  | AU-AHP  |
|             | 100          | 1985-   | AU-AN   | AU-AN   |
|             | 200          | 1985-   | AU-ANP  | AU-ANP  |
|             | 4000         | 1985-   | VO-2  | VO-2  |
|             | 5000         | 1985-   | VO-2P   | VO-2P   |
|             | CABRIO       | 1985-1995   |   |   |
| COUPE       | 1985-1995    |   |   |   |
| QUATTRO     | 1985-        |   |   |   |
| V8          | 1985-        |   |   |   |
| 100         | 1979         | NE-1  | AU-W  |   |
| 100 GLS     | 1979         | NE-1P   |   |   |
| 100 L       | 1979         |   |   |   |
| COUPE GT    | 1982-1984    | AU-1  | AU-1  |   |
| QUATTRO     | 1982-1984    | AU-HV   | AU-HV   |   |
|             |              | AU-HVP  | AU-HVP  |   |
|             |              | VO-HV   | VO-HV   |   |
|             |              | VO-VB   | VO-VB   |   |
|             |              | VO-VBP  | VO-VBP  |   |
| FOX         | 1973-1977    | VO-HV   | VO-HV   |   |
|             |              | VO-HVP  | VO-HVP  |   |
| AUSTIN      | SHERPA 185   | -   | LF-BL   | UN-1FS  |
|             | SHERPA 230   | -   | LF-RO   | UN-FT   |
|             | SHERPA 255   | -   | LF-ROP  |   |
| AUTOBIANCHI | A111         | -   | AF-7I   | IMS-3   |
|             |              |   | AF-7IP  | IMS-3P  |
|             |              |   | AF-8D   | IMS-5   |
|             |              |   | AF-8DP  | IMS-5P  |
|             |              |   | AF-8I   |   |
|             |              |   | AF-8IP  |   |
|             |              |   | AF-9D   |   |
|             |              |   | AF-9DP  |   |
|             |              |   | AF-9I   |   |
|             |              |   | AF-9IP  |   |
|             | A112         | 1971-1977   | AF-7I   | IMS-3   |
|             |              |   | AF-7IP  | IMS-3P  |
|             |              |   | FI-9I   | IMS-5   |
|             |              |   | FI-9IP  | IMS-5P  |
|             |              |   | SIP-3   |   |
|             | A112         | 1978-1981   | AF-7I   | IMS-3   |
|             |              |   | AF-7IP  | IMS-3P  |



| MARCA BRAND | MODELO MODEL |  |  |  |
|-------------|--------------|---|---|---|
| AUTOBIANCHI |              |   | FO-FR   | IMS-5   |
|             |              |   | FO-FRP  | IMS-5P  |
|             | A112         | 1981-1984   | AF-7I   | IMS-3   |
|             |              |   | AF-7IP  | IMS-3P  |
|             |              |   | FI-8I   | IMS-5   |
|             |              |   | FI-8IP  | IMS-5P  |
|             |              |   | FI-9I   |   |
|             |              |   | FI-9IP  |   |
|             | A112         | 1984-1986   | FI-3D   | FI-3D   |
|             |              |   | FI-3DP3   | FI-3DP3   |
|             |              |   | FI-6I   | FI-6I   |
|             |              |   | FI-6IP3   | FI-6IP3   |
|             |              |   |   | IMS-3   |
|             |              |   |   | IMS-3P  |
|             |              |   |   | IMS-5   |
|             |              |   |   | IMS-5P  |
|             | A112 (1.SER) | 1969-1971   | AF-7I   | IMS-3   |
|             |              |   | AF-7IP  | IMS-3P  |
|             |              |   | AF-8D   | IMS-5   |
|             |              |   | AF-8DP  | IMS-5P  |
|             |              | AF-8I   |   |   |
|             |              | AF-8IP  |   |   |
|             |              | AF-9D   |   |   |
|             |              | AF-9DP  |   |   |
|             |              | AF-9I   |   |   |
|             |              | AF-9IP  |   |   |
|             |              | FO-FR   |   |   |
|             |              | FO-FRP  |   |   |
| BIANCHINA   | -            | FEM-1D  | AF-5D   |   |
|             |              | FEM-1I  | AF-5I   |   |
|             |              | FEM-2D  | AF-6D   |   |
|             |              | FEM-2I  | AF-6I   |   |
| PRIMULA     | -            | AF-7I   |   |   |
|             |              | AF-7IP  |   |   |
|             |              | FEM-1D  |   |   |
|             |              | FEM-1I  |   |   |
|             |              | FEM-2D  |   |   |
|             |              | FEM-2I  |   |   |
|             | Y10          | 1986-   | FI-1  | FI-1  |
|             |              |   | FI-11   | FI-11   |
|             |              |   | FI-11P  | FI-11P  |
|             |              |   | FI-1P   | FI-1P   |
|             |              |   | FI-1P8  | FI-1P8  |
| BEDFORD     | MIDI VAN     | -   | TOYO-14   | TOYO-14   |
|             | MIDI WAGON   | -   | TOYO-14P  | TOYO-14P  |
|             | WINDOW VAN   | -   |   |   |
|             | RASCAL       | -   | GM-1P   | GM-1P   |
| BELLIER     | DIVANE       | 2004-2006   | SIX-3P  | SIX-3P  |
|             | JADE         | 2009  |   |   |
|             | OPALE        | 2007-2009   |   |   |
| BENTLEY     | CONTINENTAL  | -   | YA-18D  | YA-18D  |
|             | EIGHT        | -   | YA-19D  | YA-19D  |
|             | TURBO        | -   |   |   |
|             | MULSANNE     | 1987-   | YA-20I  | YA-20I  |



| MARCA BRAND      | MODELO MODEL |  |  |  |
|------------------|--------------|---|---|---|
| <b>BENTLEY</b>   |              |   | YA-21I  | YA-21I  |
| <b>BERTONE</b>   | FREECLIMBER  | -   | DAI-1P  | DAI-1P  |
|                  | SL-CABRIO    | -   | MIT-12  | MIT-12  |
|                  |              |   | MIT-7   | MIT-7   |
|                  |              |   | MIT-7P  | MIT-7P  |
| <b>BMA</b>       | AMICA 250    | -   | AF-9D   | UN-MRN  |
|                  | AMICA 360 D  | -   | AF-9DP  |   |
|                  | AMICA 50-125 | -   | AF-9I   |   |
|                  |              |   | AF-9IP  |   |
|                  |              |   | FEM-1I  |   |
| <b>BMW</b>       | 524 TD       | 1984-1986   | BM-2  | BM-2  |
|                  | SERIE 7      | 1984-1986   | BM-2P   | BM-2P   |
|                  |              |   | BM-HB   | BM-HB   |
|                  |              |   | BM-HBP  | BM-HBP  |
|                  | 1502         | 1968-1976   | BM-W  | BM-B  |
|                  | 1600         | 1968-1976   |   | HU-SX   |
|                  | 1602         | 1968-1976   |   |   |
|                  | 1800         | 1968-1976   |   |   |
|                  | 1802         | 1968-1976   |   |   |
|                  | 2000         | 1968-1976   |   |   |
|                  | 2002         | 1968-1976   |   |   |
|                  | 2000 TOURING | 1968  | BM-W  | BM-W  |
|                  | 2002 TOURING | 1979  |   |   |
|                  | 2500         | 1968-   | BM-1P   | BM-1P   |
|                  | 2800         | 1970-1975   |   |   |
|                  | 3000         | 1970-1975   |   |   |
|                  | 3800         | 1970-1975   |   |   |
|                  | BAVARIA      | 1970-1975   |   |   |
|                  | SERIE 3      | 1975-1984   | BM-3  | BM-3  |
|                  | SERIE 5      | 1975-1984   | BM-3P   | BM-3P   |
|                  | SERIE 6      | 1975-1984   | BM-HB   | BM-HB   |
|                  | SERIE 7      | 1975-1984   | BM-HBP  | BM-HBP  |
|                  |              |   | BM-NB   | BM-NB   |
|                  |              |   | BM-NBP  | BM-NBP  |
|                  | SERIE 3      | 1987-1990   | BM-2  | BM-2  |
|                  |              |   | BM-2P   | BM-2P   |
|                  |              |   | BM-NB   | BM-NB   |
|                  |              |   | BM-NBP  | BM-NBP  |
|                  | SERIE 3      | 1990-1995   | BM-4  | BM-4  |
|                  | SERIE 5      | 1988-1995   | BM-5P   | BM-5P   |
|                  | SERIE 7      | 1988-1995   |   |   |
|                  | SERIE 8      | 1988-1995   |   |   |
| <b>CARBODIES</b> | FAIRWAY FX4S | -   | LF-RO   | IN-4  |
|                  |              |   | LF-ROP  | IN-5  |
| <b>CHATENET</b>  | BAROODER     | 2001-2010   | SIX-3P  | SIX-3P  |
|                  | CH26         | 2007  |   |   |
|                  | CH28         | 2012  |   |   |
|                  | CH30         | 2010  |   |   |
|                  | CH32         | 2012  |   |   |
|                  | MEDIA        | 2000-2009   |   |   |
|                  | SPEEDINO     | 2006-2010   |   |   |
|                  | STELLA       | -   |   |   |
| <b>CHRYSLER</b>  | 024          | 1987-   | CHR-8   | CHR-8   |
|                  | 5.TH AVENUE  | -   | CHR-8P  | CHR-8P  |



| MARCA BRAND             | MODELO MODEL |  |  |  |
|-------------------------|--------------|---|---|---|
| <b>CHRYSLER</b>         | FULL SIZE V. | -   |   |   |
|                         | LEBARON      | 1989-   |   |   |
|                         | NEW YORKER   | -   |   |   |
|                         | ARROW        | -   | MIT-1I  | MIT-1I  |
|                         | D 50         | -   | MIT-1IP   | MIT-1IP   |
|                         | PICK UP      | -   |   |   |
|                         | CHALLENGER   | -   | MIT-2I  | MIT-2I  |
|                         | CONQUEST     | -   | MIT-2IP   | MIT-2IP   |
|                         | RAIDER       | -   |   |   |
|                         | SAPPORO      | -   |   |   |
|                         | COLT         | 1993-   | MIT-8D  | MIT-8D  |
|                         | VISTA        | 1993-   | MIT-8DP   | MIT-8DP   |
|                         | CONCORDE     | 1993-   | CHR-10  | CHR-10  |
|                         | FULL SIZE V. | 1993-   | CHR-10P   | CHR-10P   |
|                         | IMPERIAL     | 1993-   |   |   |
|                         | NEW YORKER   | 1993-   |   |   |
|                         | PICK UP      | 1993-   |   |   |
|                         | TOWN & CO.   | 1993-   |   |   |
|                         | VANS         | -   |   |   |
|                         | CRICKET      | -   | LF-SL   | LF-SL   |
|                         |              |   | LF-SLP  | LF-SLP  |
|                         | GR. VOYAGER  | 1996-1997   | CHR-14  | CHR-14  |
|                         | STRATUS      | 1995  | CHR-14P   | CHR-14P   |
|                         | VIPER        | 1995  | CHR-15  | CHR-15  |
|                         | VISION       | 1995  | CHR-15P   | CHR-15P   |
|                         | VOYAGER      | 1995  |   |   |
|                         | LEBARON VAN. | -   | CHR-7   | CHR-7   |
|                         | MOD. USA     | 1967-1979   | CHR-7P  | CHR-7P  |
|                         | MOD. USA     | 1980-1986   |   |   |
|                         | OMNI-HORIZON | -   |   |   |
|                         | RELIANT      | 1989-   |   |   |
|                         | TC3-ARIES    | -   |   |   |
|                         | MOD. USA     | 1990-1992   |   |   |
| <b>CHRYSLER (DODGE)</b> | 1800         | -   |   |   |
|                         | 400          | 1985-   | CHR-7   | CHR-7   |
|                         | DODGE        | 1985-1986   | CHR-7P  | CHR-7P  |
|                         | RAM 50       | -   |   |   |
|                         | 600 CARAVEL. | 1985-1989   | CHR-8   | CHR-8   |
|                         | CARAVAN      | 1991-1993   | CHR-8P  | CHR-8P  |
|                         | DAKOTA       | 1991-1993   |   |   |
|                         | DAYTONA      | 1991-1993   |   |   |
|                         | DODGE        | 1986-1990   |   |   |
|                         | LANCER       | -   |   |   |
|                         | RAM          | 1986-   |   |   |
|                         | SHADOW ES    | 1991-1992   |   |   |
|                         | TRAIL DUSTER | 1986-   |   |   |
|                         | CARAVAN      | 1993-   | CHR-10  | CHR-10  |
|                         | DAKOTA       | 1993-   | CHR-10P   | CHR-10P   |
|                         | DAYTONA      | 1993-   |   |   |
|                         | INTREPID     | 1993-   |   |   |
|                         | RAMCHARGER   | 1993-   |   |   |
|                         | SPIRIT       | 1993-   |   |   |
|                         | VIPER        | 1993-   |   |   |
|                         | COLT         | 1989-1993   | CHR-17  | CHR-17  |



# AUTOMÓVIL - CAMIONETA

## CAR - PICK-UP TRUCKS

| MARCA BRAND         | MODELO MODEL     |  |  |  |         |
|---------------------|------------------|---|---|---|---------|
| CHRYSLER (DODGE)    | VISTA            | 1989-1992   | MIT-12<br>MIT-7<br>MIT-7P   | MIT-12<br>MIT-7<br>MIT-7P   |         |
|                     | COLT             | 1993-   | MIT-13D   | MIT-13D   |         |
|                     | VISTA            | 1993-   | MIT-14D<br>MIT-8D<br>MIT-8DP  | MIT-14D<br>MIT-8D<br>MIT-8DP  |         |
|                     | DODGE            | -   | CHR-7   | CHR-7   |         |
|                     | RAMCHARGER       | 1981-1992   | CHR-7P<br>CHR-8<br>CHR-8P   | CHR-7P<br>CHR-8<br>CHR-8P   |         |
|                     | DODGE            | 1991-   | CHR-9   | CHR-9   |         |
|                     | NEON             | 1995  | CHR-9P  | CHR-9P  |         |
|                     | SPIRIT           | 1990-1992   |   |   |         |
|                     | VIPER            | 1990-1992   |   |   |         |
|                     | DODGE 400        | 1989-   | CHR-7<br>CHR-7P   |   |         |
|                     | DODGE 600        | 1989-   | CHR-8<br>CHR-8P   |   |         |
|                     | MONACO           | 1990-1993   |   | VA-10   |         |
|                     | STEALTH          | 1991-1993   | MIT-12<br>MIT-7<br>MIT-7P   | MIT-12<br>MIT-7<br>MIT-7P   |         |
|                     | CHRYSLER (EAGLE) | D 50  | -   | MIT-11  | MIT-11  |
|                     |                  | EAGLE   | -   | NE-19   | NE-28   |
|                     |                  | MEDALLION   | -   | NE-19P  | VA-10   |
| EAGLE               |                  | 1989-1990   | MIT-12<br>MIT-7<br>MIT-7P   | MIT-12<br>MIT-7<br>MIT-7P   |         |
| EAGLE               |                  | 1990-1992   |   | VA-10   |         |
| PREMIER             |                  | 1990-   |   |   |         |
| EAGLE               |                  | 1993-   | MIT-8D<br>MIT-8DP   | MIT-8D<br>MIT-8DP   |         |
| SUMMIT              |                  | 1989-1992   | CHR-17  | CHR-17  |         |
| TALON               |                  | 1989-   | MIT-12<br>MIT-7<br>MIT-7P   | MIT-12<br>MIT-7<br>MIT-7P   |         |
| SUMMIT              |                  | 1993-   | MIT-13D<br>MIT-14D<br>MIT-8D<br>MIT-8DP   | MIT-13D<br>MIT-14D<br>MIT-8D<br>MIT-8DP   |         |
| VISION              |                  | 1993-1998   | CHR-10<br>CHR-10P   | CHR-10<br>CHR-10P   |         |
| CHRYSLER (PLYMOUTH) |                  | ACCLAIM   | 1990-1992   | CHR-9   | CHR-9   |
|                     |                  | PLYMOUTH  | 1990-   | CHR-9P  | CHR-9P  |
|                     |                  | ACCLAIM   | 1993-   | CHR-10  | CHR-10  |
|                     |                  | GRAN VOYAGER  | 1993-   | CHR-10P   | CHR-10P |
|                     |                  | VOYAGER   | 1993-   |   |         |
|                     | COLT VISTA       | 1989-1992   | CHR-17  | CHR-17  |         |
|                     | LASER            | 1989-1992   |   |   |         |
|                     | COLT VISTA       | 1993-1994   | MIT-13D<br>MIT-14D  | MIT-13D<br>MIT-14D  |         |
|                     | NEON             | 1995  | CHR-14<br>CHR-14P   | CHR-14<br>CHR-14P   |         |



| MARCA BRAND         | MODELO MODEL |  |  |  |
|---------------------|--------------|---|---|---|
| CHRYSLER (PLYMOUTH) |              |   | CHR-15<br>CHR-15P   | CHR-15<br>CHR-15P   |
|                     | PLYMOUTH     | 1985-1986   | CHR-7<br>CHR-7P   | CHR-7<br>CHR-7P   |
|                     | PLYMOUTH     | 1986-1990   | CHR-8   | CHR-8   |
|                     | SUNDANCE     | 1989-   | CHR-8P  | CHR-8P  |
|                     | VOYAGER      | 1991-1992   |   |   |
|                     | CITROEN      | 2 CV  | 1970-   | CT-3<br>CT-3P<br>CT-4P  |
| ACADIANE            |              | -   | CT-2P1<br>CT-3<br>CT-3P   | RO-4D<br>RO-4I  |
| AMI 6               |              | 1969-   | CT-3  | RO-5D   |
| AMI 8               |              | 1969-   | CT-3P   | RO-5I   |
| SM                  |              | 1970-   |   |   |
| AX                  |              | 1986-1989   | CL-8P   | CL-8P   |
| BX                  |              | 1982-1990   | SIX-1<br>SIX-1P<br>SIX-2<br>SIX-2P  | SIX-1<br>SIX-1P<br>SIX-2<br>SIX-2P  |
| AX                  |              | 1989-1994   | NE-36<br>NE-36P1<br>SIX-1<br>SIX-1P<br>SIX-2<br>SIX-2P                              | NE-36<br>NE-36P1<br>SIX-1<br>SIX-1P<br>SIX-2<br>SIX-2P                              |
| AX                  |              | 1994  | NE-20P3   | NE-20P3   |
| ZX                  |              | 1994  | NE-36   | NE-36   |
| AX                  |              | 1995  | SIX-3P2   | SIX-3P2   |
| ZX                  |              | 1995  |   |   |
| AX 14D COME.        |              | -   | SIX-1<br>SIX-1P1  | SIX-1<br>SIX-1P1  |
| AXEL                |              | 1984-   | CHR-3<br>CHR-3P<br>NE-22P1  | CHR-3<br>CHR-3P<br>NE-22P1  |
| BERLINGO            |              | 1997  | SIX-3P1   | SIX-3P1   |
| EVASION             |              | 1994  |   |   |
| JUMPI               |              | 1996-   |   |   |
| BX                  |              | 1990-   | NE-36<br>NE-36P1<br>SIX-1<br>SIX-1P<br>SIX-2<br>SIX-2P                              | NE-36<br>NE-36P1<br>SIX-1<br>SIX-1P<br>SIX-2<br>SIX-2P                              |
| C-15 D              |              | -   | SIX-1   | SIX-1   |
| C-15 E              |              | -   | SIX-1P  | SIX-1P  |
| VISA                |              | 1985-   |   |   |
| ZX                  |              | 1991-1992   |   |   |
| C-25 FURGON.        |              | -   | FI-6I<br>FI-6IP3  | FI-6I<br>FI-6IP3  |
| CX                  |              | 1974-1985   | CT-3<br>CT-3P   | AB-5D<br>AB-5I<br>RO-5D   |



| MARCA BRAND | MODELO MODEL |  |  |  |
|-------------|--------------|---|---|---|
| CITROEN     |              |   |   | RO-5I   |
|             | CX           | 1985-   | SIX-1<br>SIX-1P<br>SIX-2<br>SIX-2P  | SIX-1<br>SIX-1P<br>SIX-2<br>SIX-2P  |
|             | D            | -1974   | CT-1  | RO-5D   |
|             | DS           | -1974   | CT-1P   | RO-5I   |
|             |              |   | CT-3  |   |
|             |              |   | CT-3P   |   |
|             | DYANE        | 1967-1980   | CT-2  | RO-4D   |
|             |              |   | CT-2P   | RO-4I   |
|             |              |   | CT-2P1  |   |
|             |              |   | CT-3<br>CT-3P   |   |
|             | DYANE        | 1980-   | SIX-1   | RO-4D   |
|             |              |   | SIX-1P  | RO-4I   |
|             |              |   | SIX-2   |   |
|             |              |   | SIX-2P  |   |
|             | G            | 1970-   | CT-3  | AB-5D   |
|             | GS           | 1970-   | CT-3P   | RO-5D   |
|             | GSA          | 1970-   |   | RO-5I   |
|             | JUMPER       | 1996-   | FI-11P  | FI-11P  |
|             | LN           | 1976-1984   | NE-4  | VA-6  |
|             | LNA          | 1976-1984   | NE-4P1  | VA-6P   |
|             | LNA          | 1984-   | CHR-3   | VA-6  |
|             |              |   | CHR-3P  | VA-6P   |
|             |              |   | NE-22P1   |   |
| MEHARI      | 1968-        | CT-3  | RO-4D   |   |
|             |              | CT-3P   | RO-4I   |   |
|             |              | CT-4P   |   |   |
| PLUS        | -            | FI-12   | FI-12   |   |
|             |              | FI-12P  | FI-12P  |   |
|             |              | FI-12P3   | FI-12P3   |   |
|             |              | FI-3D   | FI-3D   |   |
|             |              | FI-3DP3   | FI-3DP3   |   |
| SAXO        | 1996         | SIX-3P  | SIX-3P  |   |
| SYNERGIE    | 1994-1997    |   |   |   |
| XANTIA      | 1993-        |   |   |   |
| XM          | 1990-        |   |   |   |
| VISA        | 1979-1985    | CHR-3   | RO-4D   |   |
|             |              | CHR-3P  | RO-4I   |   |
|             |              | NE-22P1   | RO-5D   |   |
|             |              | NE-4  | RO-5I   |   |
|             |              | NE-4P1  |   |   |
| ZX          | 1992-1994    | SIX-1P2   | SIX-1P2   |   |
| DAEWOO      | DAMA         | -   | DAE-1P  | DAE-1P  |
|             | LANOS        | 1997  | DAE-4P1   | DAE-4P1   |
|             | LE MANS      | 1973-1982   | OP-6  | OP-6  |
|             |              |   | OP-7  | OP-7  |
|             |              |   | OP-8  | OP-8  |
|             |              |   | OP-9  | OP-9  |
|             |              |   | OP-BB   | OP-BB   |
| OP-EE       | OP-EE        |   |   |   |



| MARCA BRAND  | MODELO MODEL |  |  |  |
|--------------|--------------|---|---|---|
| DAEWOO       |              |   | OP-FF   | OP-FF   |
|              | LE MANS      | 1983-1984   | OP-D  | OP-D  |
|              |              |   | OP-DP   | OP-DP   |
|              |              |   | OP-S  | OP-S  |
|              |              |   | OP-SP   | OP-SP   |
|              | LE MANS      | 1985-   | OP-AB   | OP-AB   |
|              |              |   | OP-ABP  | OP-ABP  |
|              |              |   | OP-BA   | OP-BA   |
|              |              |   | OP-BAP  | OP-BAP  |
|              |              |   | OP-J<br>OP-JP   | OP-J<br>OP-JP   |
| LEGANZA      | 1997         | DAE-4D  | DAE-4D  |   |
|              |              | DAE-4DP1  | DAE-4DP1  |   |
| NUBIRA       | 1997-2000    | DAE-3D  | DAE-3D  |   |
| TACUMA       | 2000-2002    | DAE-3DP1  | DAE-3DP1  |   |
| RACER        | -            | DAE-2DP   | DAE-2DP   |   |
| DAF          | 46 L         | -   |   | FO-TC   |
|              | 46 STATIONCA | -   |   |   |
|              | 46 SUPER L   | -   |   |   |
|              | 66 GL        | -   |   |   |
|              | 66 COUPE     | -   |   |   |
|              | 66 L         | -   |   |   |
|              | 66 MARATHON  | -   |   |   |
|              | 66 SL        | -   |   |   |
|              | 66 STATIONCA | -   |   |   |
|              | 95 XF        | 1997  | CHR-3P  | CHR-3P  |
| DAIHATSU     | 4 WD TURBO   | -   | TOYO-K1   |   |
|              | PIONEER 2800 | -   | TOYO-K1P  |   |
|              | TAFT 1600 D. | -   |   |   |
|              | TAFT F10     | -   |   |   |
|              | TAFT F20     | -   |   |   |
|              | TAFT F201600 | -   |   |   |
|              | TAFT F50     | -   |   |   |
|              | TAFT F55     | -   |   |   |
|              | APPLAUSE     | 1990-   | DAI-1P  | DAI-1P  |
|              | CHARADE      | 1990-   |   |   |
|              | FEROZA       | 1988-   |   |   |
|              | ROCKY        | 1990-   |   |   |
|              | SPORTTRACK   | 1991-   |   |   |
|              | SX 228       | 1991-   |   |   |
| CHARADE      | 1977-1983    | TOYO-K1   | TOYO-K1   |   |
| CHARMANT     | 1983-        | TOYO-K1P  | TOYO-K1P  |   |
| CUORE L55    | 1976-1998    |   |   |   |
| CUORE L60    | 1976-1998    |   |   |   |
| MIRA         | 1976-        |   |   |   |
| CHARADE      | 1983-1989    | TOYO-3  | TOYO-3  |   |
| FOURTRAK 4WD | 1984-1988    | TOYO-3P   | TOYO-3P   |   |
| ROCKY        | 1984-1988    | TOYO-8  | TOYO-8  |   |
|              |              | TOYO-8P   | TOYO-8P   |   |
| CUORE 850    | 1986-1991    | TOYO-3  | TOYO-3  |   |
| ROCKY        | 1989-1990    | TOYO-3P   | TOYO-3P   |   |
| DAIMLER      | DOUBLE SIX C | -1987   | FO-FR   | CENT-3D   |
|              | LIMOUSINE    | -1987   | FO-FRP  | FO-5  |
|              | SOVEREIGN V. | -1987   |   |   |



# AUTOMÓVIL - CAMIONETA

## CAR - PICK-UP TRUCKS

| MARCA BRAND | MODELO MODEL |  |  |  |
|-------------|--------------|---|---|---|
| DAIMLER     | SOVEREIGN3.4 | -1987   |   |   |
|             | SOVEREIGN4.2 | -1987   |   |   |
|             | MODELOS      | 1990-1994   | JAU-1P  | JAU-1P  |
| DE LOREAN   | MODELOS      | 1980-1981   | NE-10   | LF-WR   |
|             |              |   | NE-10P  |   |
| DELTA MOTOR | CRUISER      | -   | TOYO-K1   | TOYO-K1   |
|             | MINI WHEEL   | -   | TOYO-K1P  | TOYO-K1P  |
|             | EXPLORER     | -   | TOYO-K1   | DAT-6   |
|             |              |   | TOYO-K1P  | DAT-6P  |
| DISALCAR    | IN 32 4X4    | -   | AF-7I   | IMS-3   |
|             | IN 50 R 4X4  | -   | AF-7IP  | IMS-3P  |
|             | IN 60 4X4    | -   |   | IMS-5   |
|             | IN 70 B 4X4  | -   |   | IMS-5P  |
|             | IN 70 CR 4X4 | -   |   |   |
|             | R 26 4x4     | -   | BH-4  |   |
| EBRO        | F 275        | -   | LMP-1   | IMS-3   |
|             | F 350        | -   | LMP-1P  | IMS-3P  |
|             |              |   | STS-2D  | IMS-5   |
|             |              |   | STS-2DP   | IMS-5P  |
|             | L 35         | -   | LMP-1   | CL-2I   |
|             | L 35/1       | -   | LMP-1P  | CL-3I   |
|             | L 60         | -   | NE-3  | FO-OA   |
|             | L 80         | -   | NE-3P   | FO-PN   |
|             |              |   | NE-3P1  |   |
|             |              |   | NE-3P2  |   |
|             | PATROL       | 1983-   | DAT-6   | DAT-6   |
|             | VANETTE      | 1983-   | DAT-6P  | DAT-6P  |
|             | TRADE 2.0    | 1983-   | STS-2D  | IMS-3   |
|             | TRADE 2.8    | 1983-   | STS-2DP   | IMS-3P  |
|             |              |   | IMS-5   |   |
|             |              |   | IMS-5P  |   |
| FERRARI     | 208          | 1975-1982   | NE-25   | IMS-3   |
|             | 308          | 1973-1975   |   | IMS-3P  |
|             | 365          | 1968-   |   | IMS-5   |
|             | DINO 246     | -   |   | IMS-5P  |
|             | 208          | 1982-   | NE-25   | AF-5D   |
|             | 308          | 1975-   |   | AF-5I   |
|             | 328          | 1985-   |   | AF-6D   |
|             |              |   |   | AF-6I   |
|             | 208 GTS      | 1982  | AF-7IP1   |   |
|             | 348          | 1984-   | FI-6I   | FI-6I   |
|             | F 40         | 1984-   | FI-6IP  | FI-6IP  |
|             | MONDIAL      | 1984-   | FI-6IP2   | FI-6IP2   |
|             | TESTA ROSSA  | 1984-   | FI-6IP3   | FI-6IP3   |
|             | 400          | 1976-   | HU-1  | AF-5D   |
|             | 412          | 1976-   | NE-25   | AF-5I   |
|             | BB 512       | 1976-   |   | AF-6D   |
|             |              |   |   | AF-6I   |
|             | GTO          | 1984  | NE-25   | AF-6D   |
|             | MONDIAL 8    | 1982  | AF-7I   | AF-5D   |
|             |              | AF-7IP  | AF-5I   |   |
|             |              | AF-7IP1   | AF-6D   |   |
|             |              |   | AF-6I   |   |
| FIAT        | 124          | 1966-   | AF-7I   | IMS-3   |

| MARCA BRAND | MODELO MODEL |  |  |  |
|-------------|--------------|---|---|---|
| FIAT        |              |   | AF-7IP  | IMS-3P  |
|             |              |   | AF-9D   | IMS-5   |
|             |              |   | AF-9DP  | IMS-5P  |
|             |              |   | FEM-1D  |   |
|             |              |   | FEM-1I  |   |
|             |              |   | FEM-2D  |   |
|             |              |   | FEM-2I  |   |
|             |              |   | FO-FR   |   |
|             |              |   | FO-FRP  |   |
|             |              |   | SIP-2   |   |
|             | 125          | -   | AF-7I   | IMS-3   |
|             |              |   | AF-7IP  | IMS-3P  |
|             |              |   | AF-9D   | IMS-5   |
|             |              |   | AF-9DP  | IMS-5P  |
|             |              | FO-FR   |   |   |
|             |              | FO-FRP  |   |   |
| 126         | -            | AF-7I   | IMS-3   |   |
|             |              | AF-7IP  | IMS-3P  |   |
|             |              | AF-9D   | IMS-5   |   |
|             |              | AF-9DP  | IMS-5P  |   |
|             |              | FI-3D   |   |   |
|             |              | FI-3DP2   |   |   |
|             |              | FI-9I   |   |   |
|             |              | FI-9IP  |   |   |
|             |              | FO-FR   |   |   |
|             |              | FO-FRP  |   |   |
|             |              | SIP-3   |   |   |
| 126 BIS     | 1987-1992    | FI-3D   | IMS-3   |   |
| 126 UP      | 1987-1992    | FI-3DP2   | IMS-3P  |   |
|             |              | FI-3DP3   | IMS-5   |   |
|             |              | FI-6I   | IMS-5P  |   |
|             |              | FI-6IP2   |   |   |
| 127         | 1973-        | AF-7I   | IMS-3   |   |
|             |              | AF-7IP  | IMS-3P  |   |
|             |              | FI-8I   | IMS-5   |   |
|             |              | FI-8IP  | IMS-5P  |   |
|             |              | FI-9I   |   |   |
|             |              | FI-9IP  |   |   |
|             |              | FO-FR   |   |   |
|             |              | FO-FRP  |   |   |
|             |              | SIP-3   |   |   |
| 127         | 1983-        | AF-7IP1   |   |   |
|             |              | FI-8IP1   |   |   |
| 128         | 1969-        | AF-7I   | IMS-3   |   |
|             |              | AF-7IP  | IMS-3P  |   |
|             |              | AF-9D   | IMS-5   |   |
|             |              | AF-9DP  | IMS-5P  |   |
|             |              | FI-9I   |   |   |
|             |              | FI-9IP  |   |   |
|             |              | FO-FR   |   |   |
|             |              | FO-FRP  |   |   |
|             |              | SIP-2   |   |   |
|             |              | SIP-3   |   |   |
| 130         | 1969-        | AF-7I   | IMS-3   |   |



| MARCA BRAND | MODELO MODEL |  |  |  |
|-------------|--------------|---|---|---|
| FIAT        |              |   | AF-7IP  | IMS-3P  |
|             |              |   | SIP-3   | IMS-5   |
|             |              |   |   | IMS-5P  |
|             | 131          | 1973-1980   | AF-7I   | IMS-3   |
|             |              |   | AF-7IP  | IMS-3P  |
|             |              |   | AF-8I   | IMS-5   |
|             |              |   | AF-8IP  | IMS-5P  |
|             |              |   | AF-9I   |   |
|             |              |   | AF-9IP  |   |
|             | 131          | 1981-   | FI-2D   | FI-3D   |
|             |              | FI-2DP3   | FI-3DP2   |   |
|             |              | FI-3D   | FI-6I   |   |
|             |              | FI-3DP2   | FI-6IP  |   |
|             |              | FI-6I   |   |   |
|             |              | FI-6IP  |   |   |
| 132         | 1973-        | AF-7I   | IMS-3   |   |
|             |              | AF-7IP  | IMS-3P  |   |
|             |              | FI-8I   | IMS-5   |   |
|             |              | FI-8IP  | IMS-5P  |   |
| 147         | 1976-        | FI-8I   | IMS-3   |   |
| 148         | 1976-        | FI-8IP  | IMS-3P  |   |
|             |              | FI-8IP1   | IMS-5   |   |
|             |              | FI-9I   | IMS-5P  |   |
|             |              | FI-9IP  |   |   |
| 500         | 1964-        | AF-9D   | AF-5D   |   |
|             |              | AF-9DP  | AF-5I   |   |
|             |              | FEM-1D  | AF-6D   |   |
|             |              | FEM-1I  | AF-6I   |   |
|             |              | FEM-2D  |   |   |
|             |              | FEM-2I  |   |   |
|             |              | FO-FR   |   |   |
|             |              | FO-FRP  |   |   |
| 600         | 1955-        | FEM-1D  | AF-5D   |   |
| 1300        | -            | FEM-1I  | AF-5I   |   |
|             |              | FEM-2D  | AF-6D   |   |
|             |              | FEM-2I  | AF-6I   |   |
| 850         | 1964-        | AF-7I   | AF-5D   |   |
|             |              | AF-7IP  | AF-5I   |   |
|             |              | FEM-1D  | AF-6D   |   |
|             |              | FEM-1I  | AF-6I   |   |
|             |              | FEM-2D  |   |   |
|             |              | FEM-2I  |   |   |
|             |              | FO-FR   |   |   |
|             |              | FO-FRP  |   |   |
|             |              | NE-3  |   |   |
|             |              | NE-3P   |   |   |
|             |              | NE-3P2  |   |   |
| 1100        | 1956-        | FEM-1D  | AF-4D   |   |
|             |              | FEM-1I  | AF-4I   |   |
|             |              | FEM-2D  | AF-5D   |   |
|             |              | FEM-2I  | AF-5I   |   |
|             |              |   | AF-6D   |   |
|             |              |   | AF-6I   |   |



| MARCA BRAND | MODELO MODEL |  |  |  |
|-------------|--------------|---|---|---|
| FIAT        | 1500         | 1967-   | FEM-1D  | AF-5D   |
|             |              |   | FEM-1I  | AF-5I   |
|             |              |   | FEM-2D  | AF-6D   |
|             |              |   | FEM-2I  | AF-6I   |
|             |              |   | SIP-2   |   |
|             | 1800         | 1967-   | SIP-2   | AF-5D   |
|             | 2100         | 1967-   |   | AF-5I   |
|             | 2300         | 1967-   |   | AF-6D   |
|             |              |   |   | AF-6I   |
|             | ARGENTA      | 1981-   | FI-2D   | FI-2D   |
|             |              | FI-2DP3   | FI-2DP3   |   |
|             |              | FI-3D   | FI-3D   |   |
|             |              | FI-3DP2   | FI-3DP2   |   |
| CINQUECENTO | 1992-1997    | FI-11   | FI-11   |   |
| DUCATO      | 1994         | FI-11P  | FI-11P  |   |
| COUPE       | 1994-1995    | FI-13   | FI-13   |   |
| TIPO        | 1988-        | FI-13P  | FI-13P  |   |
| CROMA       | 1985-1995    | FI-10   | FI-11   |   |
|             |              | FI-10P  | FI-11P  |   |
|             |              | FI-11   |   |   |
|             |              | FI-11P  |   |   |
| DINO        | -            | FO-FR   | IMS-3   |   |
|             |              | FO-FRP  | IMS-3P  |   |
|             |              | SIP-2   | IMS-5   |   |
|             |              |   | IMS-5P  |   |
| DUNA        | 1987-1991    | FI-1  | FI-1  |   |
| PANDA       | 1986-1991    | FI-1P   | FI-1P   |   |
| RITMO       | 1984-1986    |   |   |   |
| STRADA      | 1984-1986    |   |   |   |
| DUNA        | 1992-        | FI-1  | FI-1  |   |
| PANDA       | 1992-1995    | FI-11   | FI-11   |   |
| UNO         | 1983-        | FI-11P  | FI-11P  |   |
|             |              | FI-1P   | FI-1P   |   |
| FIORINO     | -            | AF-7I   | IMS-3   |   |
|             |              | AF-7IP  | IMS-3P  |   |
|             |              | AF-9D   | IMS-5   |   |
|             |              | AF-9DP  | IMS-5P  |   |
|             |              | AF-9I   |   |   |
|             |              | AF-9IP  |   |   |
|             |              | FI-8I   |   |   |
|             |              | FI-8IP  |   |   |
|             |              | FI-9I   |   |   |
|             |              | FI-9IP  |   |   |
| PANDA       | 1980-1985    | FI-7I   | IMS-3   |   |
|             |              | FI-8I   | IMS-3P  |   |
|             |              | FI-8IP  | IMS-5   |   |
|             |              | FI-8IP1   | IMS-5P  |   |
|             |              | FI-9I   |   |   |
|             |              | FI-9IP  |   |   |
| PUNTO       | 1993-1995    | FI-13   | FI-13   |   |
|             |              | FI-13P1   | FI-13P1   |   |
| REGATA      | 1983-        | FI-1  | FI-1  |   |
|             |              | FI-10   | FI-11   |   |
|             |              | FI-10P  | FI-11P  |   |









# AUTOMÓVIL - CAMIONETA

## CAR - PICK-UP TRUCKS

| MARCA BRAND | MODELO MODEL     |  |  |  |                                    |
|-------------|------------------|---|---|---|------------------------------------|
| FIAT        |                  |   | FI-11<br>FI-11P<br>FI-1P  | FI-1P   |                                    |
|             | RITMO            | 1978-1983   | FI-3D<br>FI-3DP<br>FI-3DP2<br>FI-6I<br>FI-6IP                                     | FI-3D<br>FI-3DP<br>FI-3DP2<br>FI-6I<br>FI-6IP                                     |                                    |
|             | SCUDO<br>ULYSSE  | 1995-1997<br>1994   | SIX-3P1   | SIX-3P1   |                                    |
|             | SPIDER EURO.     | -   | AF-7I<br>AF-7IP   | AF-5D<br>AF-5I<br>AF-6D<br>AF-6I  |                                    |
|             | STRADA           | 1979-1982   | FI-7I<br>FI-8I<br>FI-8IP  | FI-7I<br>FI-8I<br>FI-8IP  |                                    |
|             | STRADA           | 1982-1984   | FI-3D<br>FI-3DP<br>FI-6I<br>FI-6IP  | FI-3D<br>FI-3DP<br>FI-6I<br>FI-6IP  |                                    |
|             | TEMPRA           | 1989-1995   | FI-13<br>FI-13P<br>FI-14P   | FI-13<br>FI-13P<br>FI-14P   |                                    |
|             | X 1/9            | 1972-   | AF-7I<br>AF-7IP   | IMS-3<br>IMS-3P<br>IMS-5<br>IMS-5P  |                                    |
|             | FIAT (ARGENTINA) | 128   | -   | NE-4<br>NE-4P   | NE-46                              |
|             |                  | 133   | -   | NE-3  |                                    |
|             |                  | 600   | -   | NE-3P<br>NE-3P2   |                                    |
|             |                  | 147   | -   | NE-4<br>NE-4P   |                                    |
|             |                  | DUNA  | 1987-1991   | FI-1<br>FI-1P   | FI-1<br>FI-1P                      |
|             |                  | DUNA  | 1992-   | FI-1  | FI-1                               |
|             |                  | UNO   | 1983-   | FI-11<br>FI-11P<br>FI-1P  | FI-11<br>FI-11P<br>FI-1P           |
|             |                  | REGATTA   | 1983-   | FI-1<br>FI-10<br>FI-10P<br>FI-11<br>FI-11P<br>FI-1P                               | FI-1<br>FI-11<br>FI-11P<br>FI-1P   |
|             |                  | SPAZIO  | -   | AF-7I<br>AF-7IP<br>FI-8I<br>FI-8IP<br>FI-9I<br>FI-9IP                             | IMS-3<br>IMS-3P<br>IMS-5<br>IMS-5P |



| MARCA BRAND      | MODELO MODEL |  |                     |  |                                    |
|------------------|--------------|---|--|---|------------------------------------|
| FIAT (ARGENTINA) |              |   | FO-FR<br>FO-FRP<br>SIP-3   |   |                                    |
|                  | TEMPRA       | -   | FI-13<br>FI-13P  | FI-13<br>FI-13P   |                                    |
|                  | ELBA         | 1992-   | FI-1   | FI-1  |                                    |
| FIAT (BRASIL)    | PREMIO       | 1992-   | FI-11  | FI-11   |                                    |
|                  | UNO          | 1983-   | FI-11P<br>FI-1P  | FI-11P<br>FI-1P   |                                    |
|                  | PALIO        | 1996-1997   | FI-13P7  | FI-13P7   |                                    |
| FIAT (TURQUIA)   | 131          | 1973-1980   | AF-7I<br>AF-7IP<br>AF-8I<br>AF-8IP<br>AF-9I<br>AF-9IP  | IMS-3<br>IMS-3P<br>IMS-5<br>IMS-5P  |                                    |
|                  | 131          | 1981-   | FI-2D<br>FI-2DP3<br>FI-3D<br>FI-3DP2<br>FI-6I<br>FI-6IP  | FI-3D<br>FI-3DP2<br>FI-6I<br>FI-6IP   |                                    |
|                  | SERCE        | -   | AF-7I<br>AF-7IP<br>AF-9D<br>AF-9DP<br>FEM-1D<br>FEM-1I<br>FEM-2D<br>FEM-2I<br>FO-FR<br>FO-FRP<br>SIP-2 | IMS-3<br>IMS-3P<br>IMS-5<br>IMS-5P  |                                    |
|                  | TEMPRA       | 1989-   | FI-13<br>FI-13P<br>FI-14P  | FI-13<br>FI-13P<br>FI-14P   |                                    |
|                  | FIAT IVECO   | 131 D MAR.  | 1976-  | AF-7I<br>AF-7IP   | IMS-3<br>IMS-3P<br>IMS-5<br>IMS-5P |
|                  |              | 180   | -1989  |   |                                    |
|                  |              | 190   | -1989  |   |                                    |
|                  |              | 238   | -  | AF-7I<br>AF-7IP<br>AF-9D<br>AF-9DP<br>AF-9I<br>AF-9IP                               | AF-5D<br>AF-5I<br>AF-6D<br>AF-6I   |
|                  |              | 900 E   | 1980-  | FI-8I<br>FI-8IP   | AF-5D<br>AF-5I<br>AF-6D<br>AF-6I   |
|                  |              | 900 T   | 1976-  | AF-7I   | AF-5D                              |



| MARCA BRAND | MODELO MODEL |  |  |  |
|-------------|--------------|---|---|---|
| FIAT IVECO  |              |   | AF-7IP  | AF-5I   |
|             |              |   | AF-8D   | AF-6D   |
|             |              |   | AF-8DP  | AF-6I   |
|             |              |   | AF-8I   |   |
|             |              |   | AF-8IP  |   |
|             |              |   | AF-9D   |   |
|             |              |   | AF-9DP  |   |
|             |              |   | AF-9I   |   |
|             |              |   | AF-9IP  |   |
|             | DAILY 30     | -1984   | AF-7I   | IMS-3   |
|             | DAILY 35     | -1984   | AF-7IP  | IMS-3P  |
|             | DAILY 40     | -1984   | FI-9I   | IMS-5   |
|             | DAILY 50     | -1984   | FI-9IP  | IMS-5P  |
|             | DAILY 30     | 1985-1988   | FI-2D   | FI-2D   |
|             | DAILY 35     | 1985-1988   | FI-2DP3   | FI-2DP3   |
|             | DAILY 40     | 1985-1988   | FI-3D   | FI-3D   |
|             | DAILY 50     | 1985-1988   | FI-3DP1   | FI-3DP1   |
|             |              |   | FI-6I   | FI-6I   |
|             |              |   | FI-6IP1   | FI-6IP1   |
|             | DAILY 30     | 1989-1991   | FI-11   | FI-11   |
|             | DAILY 35     | 1989-1991   | FI-11P  | FI-11P  |
|             | DAILY 40     | 1989-1991   |   |   |
|             | DAILY 45     | 1989-1991   |   |   |
|             | DAILY 49     | 1989-1991   |   |   |
|             | DAILY 50     | 1989-1991   |   |   |
|             | FIORINO      | 1988-1996   |   |   |
|             | MARENGO R.   | 1985-1996   |   |   |
|             | PANDA        | -1994   |   |   |
|             | PENNY        | -1991   |   |   |
|             | UNO          | -1991   |   |   |
|             | DUCATO 10    | -1988   | FI-12   | FI-12   |
|             | DUCATO 13    | -1988   | FI-12P1   | FI-12P1   |
| DUCATO MAXI | -1988        | FI-12P3   | FI-12P3   |   |
|             |              | FI-3D   | FI-3D   |   |
|             |              | FI-3DP3   | FI-3DP3   |   |
|             |              | FI-6I   | FI-6I   |   |
|             |              | FI-6IP3   | FI-6IP3   |   |
| DUCATO 10   | 1989-1996    | FI-3D   | FI-3D   |   |
| DUCATO 14   | 1989-1996    | FI-3DP3   | FI-3DP3   |   |
| DUCATO 4x4  | 1989-1996    | FI-6I   | FI-6I   |   |
| DUCATO MAX  | 1989-1996    | FI-6IP3   | FI-6IP3   |   |
| FIORINO     | -1982        | AF-9D   | IMS-3   |   |
|             |              | AF-9DP  | IMS-3P  |   |
|             |              | AF-9I   | IMS-5   |   |
|             |              | AF-9IP  | IMS-5P  |   |
|             |              | FI-9I   |   |   |
|             |              | FI-9IP  |   |   |
| FIORINO     | 1983-1987    | AF-7I   | IMS-3   |   |
|             |              | AF-7IP  | IMS-3P  |   |
|             |              | FI-8IP1   | IMS-5   |   |
|             |              | FI-9I   | IMS-5P  |   |
|             |              | FI-9IP  |   |   |
| TALENTO     | -            | FI-6I   | FI-6I   |   |
|             |              | FI-6IP  | FI-6IP  |   |



| MARCA BRAND | MODELO MODEL |  |  |  |
|-------------|--------------|---|---|---|
| FORD        | CAPRI        | -   | FO-E-TC   | FO-E-TC   |
|             |              |   | FO-E-TCP  | FO-E-TCP  |
|             |              |   | FO-TC   | FO-TC   |
|             |              |   | FO-TX   | FO-TX   |
|             |              |   | FO-TXP  | FO-TXP  |
|             |              |   |   | FO-XR   |
|             | CARGO        | -   | LF-WR   | LF-WR   |
|             |              |   | NE-11   |   |
|             |              |   | NE-11P  |   |
|             |              |   | NE-24   |   |
|             |              |   | NE-24P  |   |
|             | CARGO        | 1987-1990   | NE-11   | LF-WR   |
|             |              |   | NE-11P  |   |
|             | CARGO        | 1990-   | NE-11   | NE-11   |
|             |              |   | NE-11P  | NE-11P  |
|             | CONSUL       | -   | FO-E-TC   | FO-E-TC   |
|             | CORTINA      | -   | FO-E-TCP  | FO-E-TCP  |
|             |              |   | FO-TC   | FO-TC   |
|             |              |   |   | FO-XR   |
|             | ESCORT       | -1986   | FO-E-TC   | FO-E-TC   |
|             | FIESTA       | -1988   | FO-E-TCP  | FO-E-TCP  |
|             |              |   | FO-TC   | FO-TC   |
|             |              |   | FO-TX   | FO-TX   |
|             |              |   | FO-TX1  | FO-TX1  |
|             |              |   | FO-TX1P   | FO-TX1P   |
|             |              |   | FO-TX2  | FO-TX2  |
|             |              |   | FO-TX2P   | FO-TX2P   |
|             |              |   | FO-TXP  | FO-TXP  |
|             | ESCORT       | 1986-1988   | FO-4P   | FO-4P   |
|             | GRANADA      | 1986-   |   |   |
|             | ORION        | 1986-1988   |   |   |
|             | SCORPIO      | 1986-1988   |   |   |
| SIERRA      | 1986-1988    |   |   |   |
| ESCORT      | 1989-1995    | FO-6P   | FO-6P   |   |
| FIESTA      | 1988-1995    |   |   |   |
| MONDEO      | 1993-1995    |   |   |   |
| ORION       | 1988-        |   |   |   |
| SCORPIO     | 1988-1990    |   |   |   |
| SCORPIO     | 1990-1995    |   |   |   |
| SIERRA      | 1988-1990    |   |   |   |
| SIERRA      | 1990-        |   |   |   |
| ESCORT VAN  | -            | FO-E-TC   | FO-E-TC   |   |
|             |              | FO-E-TCP  | FO-E-TCP  |   |
|             |              | FO-TX   | FO-TX   |   |
|             |              | FO-TXP  | FO-TXP  |   |
| GRANADA     | -1986        | FO-E-TC   | FO-E-TC   |   |
| ORION       | -1986        | FO-E-TCP  | FO-E-TCP  |   |
| SIERRA      | -1986        | FO-TX   | FO-TX   |   |
|             |              | FO-TX1  | FO-TX1  |   |
|             |              | FO-TX1P   | FO-TX1P   |   |
|             |              | FO-TX2  | FO-TX2  |   |
|             |              | FO-TX2P   | FO-TX2P   |   |
|             |              | FO-TXP  | FO-TXP  |   |



# AUTOMÓVIL - CAMIONETA

## CAR - PICK-UP TRUCKS

| MARCA BRAND      | MODELO MODEL |  |  |  |
|------------------|--------------|---|---|---|
| FORD             | MAVERICK     | 1993-1995   | FO-10P  | FO-10P  |
|                  | PROBE        | 1993-1996   | FO-9D   | FO-9D   |
|                  |              |   | FO-9DP  | FO-9DP  |
|                  | TAURUS       | -   | FO-E-TC   | FO-E-TC   |
|                  |              |   | FO-E-TCP  | FO-E-TCP  |
|                  | TRANSIT 100D | -   | FO-TC   | FO-PRL  |
|                  | TRANSIT F.   | -1986   | FO-E-TC   | UN-FT   |
|                  |              |   | FO-E-TCP  | UN-TF   |
|                  |              |   | FO-TX   |   |
|                  |              |   | FO-TX1  |   |
|                  |              |   | FO-TX1P   |   |
|                  |              |   | FO-TX2  |   |
|                  |              |   | FO-TX2P   |   |
|                  |              |   | FO-TXP  |   |
|                  |              | TRANSIT F.  | 1986-   | FO-22P  |
|                  |              |   | FO-4P   | FO-4P   |
| FORD (ARGENTINA) | ESCORT       | -1986   | FO-E-TC   | FO-E-TC   |
|                  |              |   | FO-E-TCP  | FO-E-TCP  |
|                  |              |   | FO-TC   | FO-TC   |
|                  |              |   | FO-TX   | FO-TX   |
|                  |              |   | FO-TX1  | FO-TX1  |
|                  |              |   | FO-TX1P   | FO-TX1P   |
|                  |              |   | FO-TX2  | FO-TX2  |
|                  |              |   | FO-TX2P   | FO-TX2P   |
|                  |              |   | FO-TXP  | FO-TXP  |
|                  | ESCORT       | 1986-1988   | FO-4P   | FO-4P   |
|                  | SIERRA       | 1986-1988   |   |   |
|                  | ESCORT       | 1988-1995   | FO-6P   | FO-6P   |
|                  | FIESTA       | 1995-1996   |   |   |
|                  | MONDEO       | 1995-1996   |   |   |
|                  | SIERRA       | 1988-1990   |   |   |
|                  | SIERRA       | 1990-   |   |   |
|                  | ESCORT VAN   | -   | FO-E-TC   | FO-E-TC   |
|                  |              |   | FO-E-TCP  | FO-E-TCP  |
|                  |              |   | FO-TX   | FO-TX   |
|                  |              |   | FO-TXP  | FO-TXP  |
| FALCON           | -            | FO-2  | FO-2  |   |
| PICK UP          | -1993        |   |   |   |
| GALAXI           | 1996         | FO-17P  | FO-17P  |   |
| GALAXY           | -1996        | FO-FHP  | FO-FHP  |   |
|                  |              | VO-HV   | VO-HV   |   |
|                  |              | VO-HVP  | VO-HVP  |   |
| PICK UP          | 1993-1994    | FO-3D   | FO-3D   |   |
|                  |              | FO-3DP  | FO-3DP  |   |
|                  |              | VO-HV   |   |   |
|                  |              | VO-HVP  |   |   |
| PICK-UP          | 1995-1996    | FO-11D  | FO-11D  |   |
| SIERRA           | -1986        | FO-E-TC   | FO-E-TC   |   |
|                  |              | FO-E-TCP  | FO-E-TCP  |   |
|                  |              | FO-TX   | FO-TX   |   |
|                  |              | FO-TX1  | FO-TX1  |   |
|                  |              | FO-TX1P   | FO-TX1P   |   |
|                  |              | FO-TX2  | FO-TX2  |   |



| MARCA BRAND         | MODELO MODEL |  |  |  |
|---------------------|--------------|---|---|---|
| FORD (ARGENTINA)    |              |   | FO-TX2P   | FO-TX2P   |
|                     |              |   | FO-TXP  | FO-TXP  |
|                     | TAURUS       | -   | FO-TX   | FO-TX   |
|                     |              |   | FO-TXP  | FO-TXP  |
| FORD (AUSTRALIA)    | CAPRI        | -1978   | FO-D  | FO-TC   |
|                     |              |   | FO-TC   | FO-XL   |
|                     | CAPRI        | 1978-   | FO-2  | FO-2  |
|                     |              |   | FO-TX   | FO-TX   |
|                     |              |   | FO-TXP  | FO-TXP  |
|                     | EXPLORER     | 1996-1997   | FO-15D  | FO-15D  |
|                     | TAURUS       | 1996-1997   | FO-15DP   | FO-15DP   |
|                     | TAURUS WAGON | 1996-1997   |   |   |
|                     | FESTIVA      | 1993-1994   | KI-1D   | KI-1D   |
|                     |              |   | KI-1DP  | KI-1DP  |
|                     | FESTIVA      | 1994  | FO-12   | FO-12   |
|                     |              |   | FO-12P  | FO-12P  |
|                     | LASER        | 1988-1990   | FO-14DP   | FO-14DP   |
|                     | LASER        | 1990-1993   | FO-13DP   | FO-13DP   |
|                     | TELSTAR      | -   | MAZ-2D  | MAZ-2D  |
|                     |              | MAZ-2DP   | MAZ-2DP   |   |
| FORD (BRASIL)       | CORCEL       | -   | FO-3D   | FO-3D   |
|                     | DEL REY      | -   | FO-3DP  | FO-3DP  |
|                     | ESCORT       | -1986   | FO-E-TC   | FO-E-TC   |
|                     |              |   | FO-E-TCP  | FO-E-TCP  |
|                     |              |   | FO-TC   | FO-TC   |
|                     |              |   | FO-TX   | FO-TX   |
|                     |              |   | FO-TX1  | FO-TX1  |
|                     |              |   | FO-TX1P   | FO-TX1P   |
|                     |              |   | FO-TX2  | FO-TX2  |
|                     |              |   | FO-TX2P   | FO-TX2P   |
|                     |              |   | FO-TXP  | FO-TXP  |
|                     | ESCORT       | 1986-1988   | FO-4P   | FO-4P   |
|                     | ESCORT       | 1988-1995   | FO-6P   | FO-6P   |
|                     | ESCORT VAN   | -   | FO-E-TC   | FO-E-TC   |
|                     | SIERRA       | -   | FO-E-TCP  | FO-E-TCP  |
| VERONA              | -            | FO-TX   | FO-TX   |   |
|                     |              | FO-TXP  | FO-TXP  |   |
| PICK-UP             | 1995-1996    | FO-3P   | FO-3P   |   |
| VARIOS              | 1996-        | FO-17P  | FO-17P  |   |
| FORD (SOUTH AFRICA) | SAPPHIRE     | 1990-   | FO-6P   | FO-6P   |
|                     | SIERRA       | 1988-1990   |   |   |
|                     | SIERRA       | 1990-   |   |   |
|                     | SIERRA       | -1986   | FO-E-TC   | FO-E-TC   |
|                     |              |   | FO-E-TCP  | FO-E-TCP  |
|                     |              |   | FO-TX   | FO-TX   |
|                     |              | FO-TX1  | FO-TX1  |   |
|                     |              | FO-TX1P   | FO-TX1P   |   |
|                     |              | FO-TX2  | FO-TX2  |   |
|                     |              | FO-TX2P   | FO-TX2P   |   |
|                     |              | FO-TXP  | FO-TXP  |   |
| SIERRA              | 1986-1988    | FO-4P   | FO-4P   |   |
| FORD (USA)          | AEROSTAR     | 1986-1991   | FO-20D  | FO-20D  |
|                     |              |   | FO-8D   | FO-8D   |
|                     | AEROSTAR     | 1991-1996   | FO-11D  | FO-1  |



| MARCA BRAND          | MODELO MODEL |  |  |  |
|----------------------|--------------|---|---|---|
| FORD (USA)           | EXPLORER     | 1991-1996   |   |   |
|                      | TAURUS S.    | 1991-1996   |   |   |
|                      | T-BIRD S.    | 1991-   |   |   |
|                      | AEROSTAR     | 1996-1997   | FO-15D  | FO-15D  |
|                      | BRONCO PICK  | 1996-1997   | FO-15DP   | FO-15DP   |
|                      | EXPLORER     | 1996-1997   |   |   |
|                      | TAURUS       | 1996-1997   |   |   |
|                      | TAURUS WAGON | 1996-1997   |   |   |
|                      | ASPIRE       | 1994  | FO-12<br>FO-12P   | FO-12<br>FO-12P   |
|                      | BRONCO       | 1967-1989   | FO-2  | FO-1  |
|                      | CROWN        | 1967-1989   |   |   |
|                      | ESCORT       | 1981-1986   |   |   |
|                      | MUSTANG      | 1967-1998   |   |   |
|                      | T-BIRD       | 1967-1984   |   |   |
|                      | TEMPO GL     | 1983-1986   |   |   |
|                      | TEMPO GLS    | 1983-1986   |   |   |
|                      | VICTORIA     | 1967-1989   |   |   |
|                      | CONCOURSE    | 1995  | FO-1  | FO-1  |
|                      | CONTOUR      | 1995-1997   | FO-8D   | FO-8D   |
|                      | CROWN        | 1990-1998   | FO-11D  | FO-11D  |
|                      | SABLE        | 1990-   | FO-20D  | FO-20D  |
|                      | TAURUS       | 1990-1996   |   |   |
|                      | T-BIRD       | 1986-1991   |   |   |
|                      | TEMPO GL     | 1986-1991   |   |   |
|                      | TEMPO GLS    | 1986-1991   |   |   |
|                      | VICTORIA     | 1990-1998   |   |   |
|                      | ESCORT       | 1990-1995   | FO-8D   | FO-8D   |
|                      | SABLE        | 1987-1989   | FO-8DP  | FO-8DP  |
|                      | TAURUS       | 1986-1989   |   |   |
|                      | FESTIVA      | 1987-1989   | MAZ-6D  | MAZ-6D  |
|                      | PROBE        | 1987-1989   | MAZ-6DP   | MAZ-6DP   |
|                      | FESTIVA      | 1990-   | FO-14DP<br>FO-7P  |   |
| FIESTA               | -1979        | FO-TC<br>LF-SL  | FO-TC<br>LF-SL  |   |
| FIESTA               | 1979-1984    | FO-TX   | FO-TX   |   |
| MERKUR               | 1985-1989    | FO-TXP  | FO-TXP  |   |
| XR4 TI               | 1985-1989    |   |   |   |
| MERKUR               | 1990-1992    | FO-14DP   | FO-14DP   |   |
| PROBE                | 1990-1992    | FO-7P   | FO-7P   |   |
| PROBE                | 1993-1996    | FO-9D<br>FO-9DP   | FO-9D<br>FO-9DP   |   |
| SCORPIO              | 1987         | FO-22P<br>FO-4P   | FO-22P<br>FO-4P   |   |
| SCORPIO              | 1988-        | FO-6P   | FO-6P   |   |
| FORD (USA) (LINCOLN) | CONTINENTAL  | 1967-1984   | FO-2  | FO-1  |
|                      | CONTINENTAL  | 1985-1991   | FO-20D  | FO-20D  |
|                      | CONTINENTAL  | 1991-1998   | FO-11D  | FO-11D  |
|                      | MARK SERIES  | 1985-1991   | FO-11D<br>FO-20D  | FO-11D<br>FO-20D  |
| FORD (USA) (MERCURY) | CAPRI        | 1970-1971   | FO-D  | FO-XL   |
|                      | CAPRI        | 1978-1983   |   |   |



| MARCA BRAND          | MODELO MODEL |  |  |  |
|----------------------|--------------|---|---|---|
| FORD (USA) (MERCURY) | CAPRI        | 1972-1978   | FO-E-TC<br>FO-E-TCP<br>FO-TC  | FO-E-TC<br>FO-E-TCP<br>FO-TC  |
|                      | CAPRI        | 1983-1991   | FO-2  | FO-2  |
|                      | MERCURY      | -1993   |   |   |
|                      | CAPRI        | 1991-   | FO-14DP   | FO-14DP   |
|                      | TRACER       | 1987-1990   | FO-7P   | FO-7P   |
|                      | COUGAR       | 1967-1984   | FO-2  | FO-1  |
|                      | MARQUIS      | 1967-1989   |   |   |
|                      | TOPAZ        | 1983-1985   |   |   |
|                      | COUGAR       | 1990-   | FO-11D  | FO-11D  |
|                      | MARQUIS      | 1991-   | FO-20D  | FO-20D  |
|                      | TOPAZ        | 1990-   |   |   |
|                      | G.MARQUIS    | 1993-1998   | FO-8D   | FO-8D   |
|                      | MERCURY      | 1993-1996   | FO-8DP1   | FO-8DP1   |
|                      | SABLE        | 1993-1996   |   |   |
|                      | MYSTIQUE     | 1995-1997   | FO-8D   | FO-8D   |
|                      | SABLE GS/LS  | 1996-1997   | FO-15D<br>FO-15DP   | FO-15D<br>FO-15DP   |
|                      | TRACER       | 1990-   | FO-8D<br>FO-8DP<br>FO-8DP1  | FO-8D<br>FO-8DP<br>FO-8DP1  |
| FREIGHTLINER         | MODELO       | 1970  | YA-8D   | YA-8D   |
| GM (BUICK)           | 3.8 P.AVENUE | 1992-   |   | GM-12   |
|                      | LESABRE      | 1991-1996   |   | GM-12P  |
|                      | REATA        | 1992-   |   | GM-H  |
|                      | RIVIERA      | 1992-1995   |   | GM-HP   |
|                      | CENTURY      | 1991-1997   | GM-8  | GM-12   |
|                      | MODELOS      | 1981  | GM-8P<br>GM-E<br>GM-EP  | GM-12P<br>GM-H<br>GM-HP   |
|                      | LESABRE      | 1996-1997   |   | GM-14   |
|                      | ROADMASTER   | 1996-1997   |   | GM-14P<br>GM-25<br>GM-25P   |
|                      | MODELOS      | 1935-1966   | BAS-1I  | BAS-1I  |
|                      | MODELOS      | 1966  | GM-6  | GM-6  |
|                      | MODELOS      | 1967  | GM-6P   | GM-6P   |
|                      | MODELOS      | 1971  | GM-A  | GM-A  |
|                      | MODELOS      | 1975  | GM-AP   | GM-AP   |
|                      | MODELOS      | 1986  |   |   |
|                      | MODELOS      | 1968  | GM-7  | GM-7  |
|                      | MODELOS      | 1972  | GM-7P<br>GM-C<br>GM-CP  | GM-7P<br>GM-C<br>GM-CP  |
|                      | MODELOS      | 1969  | GM-8  | GM-8  |
| MODELOS              | 1973         | GM-8P<br>GM-E<br>GM-EP  | GM-8P<br>GM-E<br>GM-EP  |   |
| MODELOS              | 1970         | GM-9  | GM-9  |   |
| MODELOS              | 1974         | GM-9P   | GM-9P   |   |
| MODELOS              | 1978         | GM-J<br>GM-JP   | GM-J<br>GM-JP   |   |
| MODELOS              | 1976         | GM-7  | GM-11   |   |



# AUTOMÓVIL - CAMIONETA

## CAR - PICK-UP TRUCKS

| MARCA BRAND  | MODELO MODEL |  |  |  |
|--------------|--------------|---|---|---|
| GM (BUICK)   |              |   | GM-7P   | GM-11P  |
|              |              |   | GM-C  | GM-7  |
|              |              |   | GM-CP   | GM-7P   |
|              |              |   |   | GM-C  |
|              |              |   |   | GM-CP   |
|              |              |   |   | GM-D  |
|              |              |   |   | GM-DP   |
|              | MODELOS      | 1977  | GM-8  | GM-12   |
|              |              |   | GM-8P   | GM-12P  |
|              |              |   | GM-E  | GM-8  |
|              |              |   | GM-EP   | GM-8P   |
|              |              |   |   | GM-E  |
|              |              |   |   | GM-EP   |
|              |              |   |   | GM-H  |
|              |              |   |   | GM-HP   |
|              | MODELOS      | 1979  | GM-6  | GM-10   |
|              |              |   | GM-6P   | GM-10P  |
|              |              |   | GM-A  | GM-6  |
|              |              |   | GM-AP   | GM-6P   |
|              |              |   |   | GM-A  |
|              |              |   |   | GM-AP   |
|              |              |   |   | GM-B  |
|              |              |   |   | GM-BP   |
|              | MODELOS      | 1980  | GM-7  | GM-11   |
|              |              |   | GM-7P   | GM-11P  |
|              |              | GM-C  | GM-D  |   |
|              |              | GM-CP   | GM-DP   |   |
| MODELOS      | 1982         | GM-9  | GM-13   |   |
|              |              | GM-9P   | GM-13P  |   |
|              |              | GM-J  | GM-K  |   |
|              |              | GM-JP   | GM-KP   |   |
| MODELOS      | 1983         | GM-6  | GM-10   |   |
|              |              | GM-6P   | GM-10P  |   |
|              |              | GM-A  | GM-B  |   |
|              |              | GM-AP   | GM-BP   |   |
| MODELOS      | 1984         | GM-6  | GM-10   |   |
| MODELOS      | 1985         | GM-6P   | GM-10P  |   |
|              |              | GM-7  | GM-7  |   |
|              |              | GM-7P   | GM-7P   |   |
|              |              | GM-A  | GM-B  |   |
|              |              | GM-AP   | GM-BP   |   |
|              |              | GM-C  | GM-C  |   |
|              |              | GM-CP   | GM-CP   |   |
| REGAL        | 1988-1990    | GM-19P  |   |   |
| REGAL        | 1991-        | GM-20P  |   |   |
| RIVIERA      | 1995         | GM-14   | GM-14   |   |
| SKYLARK      | 1994         | GM-14P  | GM-14P  |   |
|              |              | GM-25   | GM-25   |   |
|              |              | GM-25P  | GM-25P  |   |
| RIVIERA 3.8V | 1989-1990    |   | GM-11   |   |
|              |              |   | GM-11P  |   |
|              |              |   | GM-D  |   |
|              |              |   | GM-DP   |   |
| SKYLARK      | 1992-1993    | GM-22   | GM-22   |   |



| MARCA BRAND   | MODELO MODEL |  |  |  |
|---------------|--------------|---|---|---|
| GM (BUICK)    |              |   | GM-22P  | GM-22P  |
|               |              |   | GM-23   | GM-23   |
|               |              |   | GM-23P  | GM-23P  |
| GM (CADILLAC) | ALLANTE      | 1987-1988   | GM-16P  |   |
|               | BROUGHAM     | 1996-1997   |   | GM-12   |
|               | C.DE VILLE   | 1991-   |   | GM-12P  |
|               | ELDORADO-TC  | 1991-   |   | GM-H  |
|               | FLEETWOOD    | 1991-   |   | GM-HP   |
|               | SEVILLE      | 1991-   |   |   |
|               | ELDORADO-TC  | 1989-1990   |   | GM-11   |
|               |              |   |   | GM-11P  |
|               |              |   |   | GM-D  |
|               |              |   |   | GM-DP   |
|               | MODELOS      | 1935-1966   | BAS-11  | BAS-11  |
|               | MODELOS      | 1966  | GM-6  | GM-6  |
|               | MODELOS      | 1967  | GM-6P   | GM-6P   |
|               | MODELOS      | 1971  | GM-A  | GM-A  |
|               | MODELOS      | 1975  | GM-AP   | GM-AP   |
|               | MODELOS      | 1986  |   |   |
|               | MODELOS      | 1968  | GM-7  | GM-7  |
|               | MODELOS      | 1972  | GM-7P   | GM-7P   |
|               |              |   | GM-C  | GM-C  |
|               |              |   | GM-CP   | GM-CP   |
|               | MODELOS      | 1969  | GM-8  | GM-8  |
|               | MODELOS      | 1973  | GM-8P   | GM-8P   |
|               |              |   | GM-E  | GM-E  |
|               |              |   | GM-EP   | GM-EP   |
|               | MODELOS      | 1970  | GM-9  | GM-9  |
| MODELOS       | 1974         | GM-9P   | GM-9P   |   |
| MODELOS       | 1978         | GM-J  | GM-J  |   |
|               |              | GM-JP   | GM-JP   |   |
| MODELOS       | 1976         | GM-7  | GM-11   |   |
|               |              | GM-7P   | GM-11P  |   |
|               |              | GM-C  | GM-7  |   |
|               |              | GM-CP   | GM-7P   |   |
|               |              |   | GM-C  |   |
|               |              |   | GM-CP   |   |
|               |              |   | GM-D  |   |
|               |              |   | GM-DP   |   |
| MODELOS       | 1977         | GM-8  | GM-12   |   |
|               |              | GM-8P   | GM-12P  |   |
|               |              | GM-E  | GM-8  |   |
|               |              | GM-EP   | GM-8P   |   |
|               |              |   | GM-E  |   |
|               |              |   | GM-EP   |   |
|               |              |   | GM-H  |   |
|               |              |   | GM-HP   |   |
| MODELOS       | 1979         | GM-6  | GM-10   |   |
|               |              | GM-6P   | GM-10P  |   |
|               |              | GM-A  | GM-6  |   |
|               |              | GM-AP   | GM-6P   |   |
|               |              |   | GM-A  |   |
|               |              |   | GM-AP   |   |
|               |              |   | GM-B  |   |



| MARCA BRAND   | MODELO MODEL        |  |  |  |                        |
|---------------|---------------------|---|---|---|------------------------|
| GM (CADILLAC) |                     |   |   | GM-BP   |                        |
|               | MODELOS             | 1980  | GM-7<br>GM-7P<br>GM-C<br>GM-CP  | GM-11<br>GM-11P<br>GM-D<br>GM-DP  |                        |
|               | MODELOS             | 1981  | GM-8<br>GM-8P<br>GM-E<br>GM-EP  | GM-12<br>GM-12P<br>GM-H<br>GM-HP  |                        |
|               | MODELOS             | 1982  | GM-9<br>GM-9P<br>GM-J<br>GM-JP  | GM-13<br>GM-13P<br>GM-K<br>GM-KP  |                        |
|               | MODELOS             | 1983  | GM-6<br>GM-6P<br>GM-A<br>GM-AP  | GM-10<br>GM-10P<br>GM-B<br>GM-BP  |                        |
|               | MODELOS             | 1984  | GM-6  | GM-10   |                        |
|               | MODELOS             | 1985  | GM-6P<br>GM-7<br>GM-7P<br>GM-A<br>GM-AP<br>GM-C<br>GM-CP                          | GM-10P<br>GM-7<br>GM-7P<br>GM-B<br>GM-BP<br>GM-C<br>GM-CP                         |                        |
|               | GM (CHEVROLET BRA.) | CHEVAIR   | -   | OP-WHP  | OP-WHP                 |
|               |                     | CHEVROLET   | 1982-1987   | OP-WYP  | OP-WYP                 |
|               |                     | COMMODORE   | -   |   |                        |
|               |                     | MONZA   | 1982-1987   |   |                        |
|               |                     | OMEGA   | -   |   |                        |
|               |                     | CHEVETTE  | 1987-1989   | OP-R  | OP-R                   |
|               |                     | CHEVROLET   | 1987-   | OP-RP<br>OP-T<br>OP-TP  | OP-RP<br>OP-T<br>OP-TP |
|               |                     | CHEVROLET   | 1989-1990   | OP-D  | OP-D                   |
| PANEMA        |                     | 1989-   | OP-DP<br>OP-S<br>OP-SP  | OP-DP<br>OP-S<br>OP-SP  |                        |
| CHEVROLET     |                     | 1990-   | SUZU-7  | SUZU-7  |                        |
| SPRINT 1.0    |                     | -   | SUZU-7P   | SUZU-7P   |                        |
| DIPLOMATA     |                     | -   | CHR-8<br>CHR-8P   | CHR-8<br>CHR-8P   |                        |
| MODELOS       |                     | 1935-1966   | BAS-11  | BAS-11  |                        |
| MODELOS       |                     | 1966  | GM-6  | GM-6  |                        |
| MODELOS       |                     | 1967  | GM-6P   | GM-6P   |                        |
| MODELOS       |                     | 1971  | GM-A  | GM-A  |                        |
| MODELOS       |                     | 1975  | GM-AP   | GM-AP   |                        |
| MODELOS       |                     | 1986  |   |   |                        |
| MODELOS       |                     | 1968  | GM-7  | GM-7  |                        |
| MODELOS       |                     | 1972  | GM-7P<br>GM-C<br>GM-CP  | GM-7P<br>GM-C<br>GM-CP  |                        |
| MODELOS       | 1969                | GM-8  | GM-8  |   |                        |
| MODELOS       | 1973                | GM-8P   | GM-8P   |   |                        |



| MARCA BRAND         | MODELO MODEL |  |  |  |
|---------------------|--------------|---|---|---|
| GM (CHEVROLET BRA.) |              |   | GM-E<br>GM-EP   | GM-E<br>GM-EP   |
|                     | MODELOS      | 1970  | GM-9  | GM-9  |
|                     | MODELOS      | 1974  | GM-9P   | GM-9P   |
|                     | MODELOS      | 1978  | GM-J<br>GM-JP   | GM-J<br>GM-JP   |
|                     | MODELOS      | 1976  | GM-7<br>GM-7P<br>GM-C<br>GM-CP  | GM-11<br>GM-11P<br>GM-7<br>GM-7P<br>GM-C<br>GM-CP                                   |
|                     | MODELOS      | 1977  | GM-8<br>GM-8P<br>GM-E<br>GM-EP  | GM-12<br>GM-12P<br>GM-8<br>GM-8P<br>GM-E<br>GM-EP<br>GM-H<br>GM-HP                  |
|                     | MODELOS      | 1979  | GM-6<br>GM-6P<br>GM-A<br>GM-AP  | GM-10<br>GM-10P<br>GM-6<br>GM-6P<br>GM-A<br>GM-AP<br>GM-B<br>GM-BP                  |
|                     | MODELOS      | 1980  | GM-7<br>GM-7P<br>GM-C<br>GM-CP  | GM-11<br>GM-11P<br>GM-D<br>GM-DP  |
|                     | MODELOS      | 1981  | GM-8<br>GM-8P<br>GM-E<br>GM-EP  | GM-12<br>GM-12P<br>GM-H<br>GM-HP  |
|                     | MODELOS      | 1982  | GM-9<br>GM-9P<br>GM-J<br>GM-JP  | GM-13<br>GM-13P<br>GM-K<br>GM-KP  |
|                     | MODELOS      | 1983  | GM-6<br>GM-6P<br>GM-A<br>GM-AP  | GM-10<br>GM-10P<br>GM-B<br>GM-BP  |
|                     | MODELOS      | 1984  | GM-6  | GM-10   |
|                     | MODELOS      | 1985  | GM-6P<br>GM-7<br>GM-7P<br>GM-A<br>GM-AP<br>GM-C<br>GM-CP                            | GM-10P<br>GM-7<br>GM-7P<br>GM-B<br>GM-BP<br>GM-C<br>GM-CP                           |



# AUTOMÓVIL - CAMIONETA

## CAR - PICK-UP TRUCKS

| MARCA BRAND    | MODELO MODEL |  |  |  |
|----------------|--------------|---|---|---|
| GM (CHEVROLET) | ASTRO VAN    | 1996-1997   | GM-14   | GM-14   |
|                | CAVALIER     | 1996-1997   | GM-14P  | GM-14P  |
|                | LARGE BLAZER | 1996-1997   | GM-25   | GM-25   |
|                | LARGE PICKUP | 1996-1997   | GM-25P  | GM-25P  |
|                | MODELOS      | 1995  |   |   |
|                | S-10 BLAZER  | 1996-1997   |   |   |
|                | S-10 PICKUP  | 1996-1997   |   |   |
|                | VENTURE      | 1997  |   |   |
|                | BERETTA      | 1987-1990   | GM-17P  | GM-11   |
|                | CORSICA      | 1987-1990   |   | GM-11P  |
|                |              |   |   | GM-D  |
|                |              |   |   | GM-DP   |
|                | BERETTA      | 1991-   | GM-18P  | GM-12   |
|                | CORSICA      | 1991-   |   | GM-12P  |
|                |              |   |   | GM-H  |
|                |              |   |   | GM-HP   |
|                | CAMARO       | 1989-1990   |   | GM-11   |
|                | CORVETTE     | 1989-1990   |   | GM-11P  |
|                |              |   |   | GM-D  |
|                |              |   |   | GM-DP   |
|                | CAMARO       | 1991-   |   | GM-12   |
|                | CAVALIER RS  | 1991-   |   | GM-12P  |
|                | CORVETTE     | 1991-   |   | GM-H  |
|                |              |   |   | GM-HP   |
|                | CAVALIER LS  | 1991-1992   | GM-22   |   |
|                |              |   | GM-22P  |   |
|                | CAVALIER LS  | 1993-   | GM-23   |   |
|                |              |   | GM-23P  |   |
|                | COLORADO     | 2004  | TOYO-15   | TOYO-15   |
|                |              |   | TOYO-15P  | TOYO-15P  |
|                | IMPALA       | 2000-2005   | GM-14   | GM-14   |
|                |              |   | GM-14P  | GM-14P  |
| KODIAK 6       | 1997         | GM-8  | GM-12   |   |
| MODELOS        | 1981         | GM-8P   | GM-12P  |   |
| WHEELER        | 1997         | GM-E  | GM-H  |   |
|                |              | GM-EP   | GM-HP   |   |
| LUMINA         | 1988-1990    | GM-19P  | GM-11   |   |
|                |              |   | GM-11P  |   |
|                |              |   | GM-D  |   |
|                |              |   | GM-DP   |   |
| LUMINA         | 1991-        | GM-20P  | GM-12   |   |
|                |              |   | GM-12P  |   |
|                |              |   | GM-H  |   |
|                |              |   | GM-HP   |   |
| MODELOS        | 1935-1966    | BAS-11  | BAS-11  |   |
| MODELOS        | 1966         | GM-6  | GM-6  |   |
| MODELOS        | 1967         | GM-6P   | GM-6P   |   |
| MODELOS        | 1971         | GM-A  | GM-A  |   |
| MODELOS        | 1975         | GM-AP   | GM-AP   |   |
| MODELOS        | 1986         |   |   |   |
| MODELOS        | 1968         | GM-7  | GM-7  |   |
| MODELOS        | 1972         | GM-7P   | GM-7P   |   |
|                |              | GM-C  | GM-C  |   |
|                |              | GM-CP   | GM-CP   |   |

| MARCA BRAND    | MODELO MODEL |  |  |  |
|----------------|--------------|---|---|---|
| GM (CHEVROLET) | MODELOS      | 1969  | GM-8  | GM-8  |
|                | MODELOS      | 1973  | GM-8P   | GM-8P   |
|                |              |   | GM-E  | GM-E  |
|                |              |   | GM-EP   | GM-EP   |
|                | MODELOS      | 1970  | GM-9  | GM-9  |
|                | MODELOS      | 1974  | GM-9P   | GM-9P   |
|                | MODELOS      | 1978  | GM-J  | GM-J  |
|                |              |   | GM-JP   | GM-JP   |
|                | MODELOS      | 1976  | GM-7  | GM-11   |
|                |              |   | GM-7P   | GM-11P  |
|                |              |   | GM-C  | GM-7  |
|                |              |   | GM-CP   | GM-7P   |
|                |              |   |   | GM-C  |
|                |              |   |   | GM-CP   |
|                |              |   |   | GM-D  |
|                |              |   |   | GM-DP   |
|                | MODELOS      | 1977  | GM-8  | GM-12   |
|                |              |   | GM-8P   | GM-12P  |
|                |              |   | GM-E  | GM-8  |
|                |              |   | GM-EP   | GM-8P   |
|                |              |   |   | GM-E  |
|                |              |   |   | GM-EP   |
|                |              |   |   | GM-H  |
|                |              |   |   | GM-HP   |
|                | MODELOS      | 1979  | GM-6  | GM-10   |
|                |              |   | GM-6P   | GM-10P  |
|                |              |   | GM-A  | GM-6  |
|                |              |   | GM-AP   | GM-6P   |
|                |              |   |   | GM-A  |
|                |              |   |   | GM-AP   |
|                |              |   |   | GM-B  |
|                |              |   |   | GM-BP   |
| MODELOS        | 1980         | GM-7  | GM-11   |   |
|                |              | GM-7P   | GM-11P  |   |
|                |              | GM-C  | GM-D  |   |
|                |              | GM-CP   | GM-DP   |   |
| MODELOS        | 1982         | GM-9  | GM-13   |   |
|                |              | GM-9P   | GM-13P  |   |
|                |              | GM-J  | GM-K  |   |
|                |              | GM-JP   | GM-KP   |   |
| MODELOS        | 1983         | GM-6  | GM-10   |   |
|                |              | GM-6P   | GM-10P  |   |
|                |              | GM-A  | GM-B  |   |
|                |              | GM-AP   | GM-BP   |   |
| MODELOS        | 1984         | GM-6  | GM-10   |   |
| MODELOS        | 1985         | GM-6P   | GM-10P  |   |
|                |              | GM-7  | GM-7  |   |
|                |              | GM-7P   | GM-7P   |   |
|                |              | GM-A  | GM-B  |   |
|                |              | GM-AP   | GM-BP   |   |
|                |              | GM-C  | GM-C  |   |
|                |              | GM-CP   | GM-CP   |   |
| SPARK          | -            | DAE-3P2   | DAE-3P2   |   |
| SPECTRUM       | 1985-1989    | GM-2  | GM-2  |   |



| MARCA BRAND    | MODELO MODEL |  |  |  |
|----------------|--------------|---|---|---|
| GM (CHEVROLET) | SPRINT       | 1985-1988   | GM-2P   | GM-2P   |
|                |              |   | GM-1P   | GM-1P   |
|                |              |   | MIT-2I  | MIT-2I  |
| GM (GEO)       | METRO        | 1989-   | GM-5  | GM-5  |
|                | STROM        | 1990-   | GM-5P   | GM-5P   |
|                | PRIZM        | 1993-1994   | GM-24   | GM-24   |
|                |              |   | GM-24P  | GM-24P  |
| SPECTRUM       | 1985-        | GM-2  | GM-2  |   |
|                | STROM        | 1989-1990   | GM-2P   | GM-2P   |
| GM (GMC)       | MODELOS      | 1935-1966   | BAS-1I  | BAS-1I  |
|                | MODELOS      | 1966  | GM-6  | GM-6  |
|                | MODELOS      | 1967  | GM-6P   | GM-6P   |
|                | MODELOS      | 1971  | GM-A  | GM-A  |
|                | MODELOS      | 1975  | GM-AP   | GM-AP   |
|                | MODELOS      | 1986  |   |   |
|                | MODELOS      | 1968  | GM-7  | GM-7  |
|                | MODELOS      | 1972  | GM-7P   | GM-7P   |
|                |              |   | GM-C  | GM-C  |
|                |              |   | GM-CP   | GM-CP   |
|                | MODELOS      | 1969  | GM-8  | GM-8  |
|                | MODELOS      | 1973  | GM-8P   | GM-8P   |
|                |              |   | GM-E  | GM-E  |
|                |              |   | GM-EP   | GM-EP   |
|                | MODELOS      | 1970  | GM-9  | GM-9  |
|                | MODELOS      | 1974  | GM-9P   | GM-9P   |
|                |              |   | GM-J  | GM-J  |
|                | MODELOS      | 1978  | GM-JP   | GM-JP   |
|                |              |   |   |   |
|                | MODELOS      | 1976  | GM-7  | GM-11   |
|                |              |   | GM-7P   | GM-11P  |
|                |              |   | GM-C  | GM-7  |
|                |              |   | GM-CP   | GM-7P   |
|                |              |   |   | GM-C  |
|                |              |   |   | GM-CP   |
|                |              |   |   | GM-DP   |
|                | MODELOS      | 1977  | GM-8  | GM-12   |
| GM-8P          |              |   | GM-12P  |   |
| GM-E           |              |   | GM-8  |   |
| GM-EP          |              |   | GM-8P   |   |
|                |              |   | GM-E  |   |
|                |              | GM-EP   | GM-H  |   |
|                |              |   | GM-HP   |   |
| MODELOS        | 1979         | GM-6  | GM-10   |   |
|                |              | GM-6P   | GM-10P  |   |
|                |              | GM-A  | GM-6  |   |
|                |              | GM-AP   | GM-6P   |   |
|                |              |   | GM-A  |   |
|                |              | GM-AP   | GM-B  |   |
|                |              |   | GM-BP   |   |
| MODELOS        | 1980         | GM-7  | GM-11   |   |
| SIERRA GLE     | 1991-        | GM-7P   | GM-11P  |   |
|                |              | GM-C  | GM-D  |   |



| MARCA BRAND      | MODELO MODEL |  |  |  |
|------------------|--------------|---|---|---|
| GM (GMC)         |              |   | GM-CP   | GM-DP   |
|                  | MODELOS      | 1981  | GM-8  | GM-12   |
|                  |              |   | GM-8P   | GM-12P  |
|                  |              |   | GM-E  | GM-H  |
|                  |              |   | GM-EP   | GM-HP   |
|                  | MODELOS      | 1982  | GM-9  | GM-13   |
|                  |              |   | GM-9P   | GM-13P  |
|                  |              |   | GM-J  | GM-K  |
|                  |              |   | GM-JP   | GM-KP   |
|                  | MODELOS      | 1983  | GM-6  | GM-10   |
|                  |              |   | GM-6P   | GM-10P  |
|                  |              |   | GM-A  | GM-B  |
|                  |              |   | GM-AP   | GM-BP   |
|                  | MODELOS      | 1984  | GM-6  | GM-10   |
|                  | MODELOS      | 1985  | GM-6P   | GM-10P  |
|                  |              |   | GM-7  | GM-7  |
|                  |              |   | GM-7P   | GM-7P   |
| GM-A             |              |   | GM-B  |   |
| GM-AP            |              |   | GM-BP   |   |
| GM-C             |              |   | GM-C  |   |
| GM-CP            |              |   | GM-CP   |   |
| GM (OLDS MOBILE) | 98 REGENCY   | 1991-   |   | GM-12   |
|                  | DELTA 88 RO. | 1992-   |   | GM-12P  |
|                  | TORONADO     | 1991-   |   | GM-H  |
|                  |              |   |   | GM-HP   |
|                  | ACHIEVA      | 1992-1993   | GM-22   |   |
|                  |              |   | GM-22P  |   |
|                  |              |   | GM-23   |   |
|                  |              |   | GM-23P  |   |
|                  | ACHIEVA      | 1994  | GM-14   | GM-14   |
|                  | AURORA       | 1995  | GM-14P  | GM-14P  |
|                  |              |   | GM-25   | GM-25   |
|                  |              | GM-25P  | GM-25P  |   |
| ALERO            | 00-04        | GM-14   | GM-14   |   |
| INTRIGUE         | 00-03        | GM-14P  | GM-14P  |   |
| CUTLASS          | 1988-1990    | GM-19P  |   |   |
| SILHOUETTE       | 1988-1990    |   |   |   |
| CUTLASS SUP.     | 1991-        | GM-20P  |   |   |
| MODELOS          | 1935-1966    | BAS-1I  | BAS-1I  |   |
| MODELOS          | 1966         | GM-6  | GM-6  |   |
| MODELOS          | 1967         | GM-6P   | GM-6P   |   |
| MODELOS          | 1971         | GM-A  | GM-A  |   |
| MODELOS          | 1975         | GM-AP   | GM-AP   |   |
| MODELOS          | 1986         |   |   |   |
| MODELOS          | 1968         | GM-7  | GM-7  |   |
| MODELOS          | 1972         | GM-7P   | GM-7P   |   |
|                  |              | GM-C  | GM-C  |   |
|                  |              | GM-CP   | GM-CP   |   |
| MODELOS          | 1969         | GM-8  | GM-8  |   |
| MODELOS          | 1973         | GM-8P   | GM-8P   |   |
|                  |              | GM-E  | GM-E  |   |
|                  |              | GM-EP   | GM-EP   |   |
| MODELOS          | 1970         | GM-9  | GM-9  |   |









# AUTOMÓVIL - CAMIONETA

## CAR - PICK-UP TRUCKS

| MARCA BRAND      | MODELO MODEL |  |  |  |
|------------------|--------------|---|---|---|
| GM (OLDS MOBILE) | MODELOS      | 1974  | GM-9P   | GM-9P   |
|                  | MODELOS      | 1978  | GM-J  | GM-J  |
|                  |              |   | GM-JP   | GM-JP   |
|                  | MODELOS      | 1976  | GM-7  | GM-11   |
|                  |              |   | GM-7P   | GM-11P  |
|                  |              |   | GM-C  | GM-7  |
|                  |              |   | GM-CP   | GM-7P   |
|                  |              |   |   | GM-C  |
|                  |              |   |   | GM-CP   |
|                  |              |   |   | GM-D  |
|                  |              |   |   | GM-DP   |
|                  | MODELOS      | 1977  | GM-8  | GM-12   |
|                  |              |   | GM-8P   | GM-12P  |
|                  |              |   | GM-E  | GM-8  |
|                  |              |   | GM-EP   | GM-8P   |
|                  |              |   |   | GM-E  |
|                  |              |   |   | GM-EP   |
|                  |              |   |   | GM-H  |
|                  |              |   |   | GM-HP   |
|                  | MODELOS      | 1979  | GM-6  | GM-10   |
|                  |              |   | GM-6P   | GM-10P  |
|                  |              |   | GM-A  | GM-6  |
|                  |              |   | GM-AP   | GM-6P   |
|                  |              |   |   | GM-A  |
|                  |              |   |   | GM-AP   |
|                  |              |   |   | GM-B  |
|                  |              |   |   | GM-BP   |
|                  | MODELOS      | 1980  | GM-7  | GM-11   |
|                  |              |   | GM-7P   | GM-11P  |
|                  |              |   | GM-C  | GM-D  |
|                  |              |   | GM-CP   | GM-DP   |
|                  | MODELOS      | 1981  | GM-8  | GM-12   |
|                  |              |   | GM-8P   | GM-12P  |
|                  |              |   | GM-E  | GM-H  |
|                  |              |   | GM-EP   | GM-HP   |
|                  | MODELOS      | 1982  | GM-9  | GM-13   |
|                  |              |   | GM-9P   | GM-13P  |
|                  |              |   | GM-J  | GM-K  |
|                  |              |   | GM-JP   | GM-KP   |
|                  | MODELOS      | 1983  | GM-6  | GM-10   |
|                  |              |   | GM-6P   | GM-10P  |
|                  |              |   | GM-A  | GM-B  |
|                  |              |   | GM-AP   | GM-BP   |
|                  | MODELOS      | 1984  | GM-6  | GM-10   |
|                  | MODELOS      | 1985  | GM-6P   | GM-10P  |
|                  |              |   | GM-7  | GM-7  |
|                  |              |   | GM-7P   | GM-7P   |
|                  |              | GM-A  | GM-B  |   |
|                  |              | GM-AP   | GM-BP   |   |
|                  |              | GM-C  | GM-C  |   |
|                  |              | GM-CP   | GM-CP   |   |
| TORONADO         | 1989-1990    |   | GM-11   |   |
|                  |              |   | GM-11P  |   |
|                  |              |   | GM-D  |   |
|                  |              |   | GM-DP   |   |



| MARCA BRAND  | MODELO MODEL |  |  |  |
|--------------|--------------|---|---|---|
| GM (PONTIAC) | BONNEVILLE   | 1992-   |   | GM-12   |
|              | FIREBIRD     | 1991-   |   | GM-12P  |
|              | FORMULA      | 1991-   |   | GM-H  |
|              | GTA          | 1991-   |   | GM-HP   |
|              | TRANS AM     | 1991-   |   |   |
|              | GRAND AM     | 00-05   | GM-14   | GM-14   |
|              | TORRENT      | 2000-2005   | GM-14P  | GM-14P  |
|              | GRAND AM     | 1992-1993   | GM-22   |   |
|              | SUNBIRD      | 1992-1993   | GM-22P  |   |
|              |              |   | GM-23   |   |
|              |              |   | GM-23P  |   |
|              | GRAND AM     | 1994  | GM-14   | GM-14   |
|              |              |   | GM-14P  | GM-14P  |
|              |              |   | GM-25   | GM-25   |
|              |              |   | GM-25P  | GM-25P  |
|              | GRAND PRIX   | 1991-1994   | GM-20P  |   |
|              | LE MANS      | 1987-   | OP-S  | OP-S  |
|              |              |   | OP-SP   | OP-SP   |
|              | MODELOS      | 1935-1966   | BAS-11  | BAS-11  |
|              | MODELOS      | 1966  | GM-6  | GM-6  |
|              | MODELOS      | 1967  | GM-6P   | GM-6P   |
|              | MODELOS      | 1971  | GM-A  | GM-A  |
|              | MODELOS      | 1975  | GM-AP   | GM-AP   |
|              | MODELOS      | 1986  |   |   |
|              | MODELOS      | 1968  | GM-7  | GM-7  |
|              | MODELOS      | 1972  | GM-7P   | GM-7P   |
|              |              |   | GM-C  | GM-C  |
|              |              |   | GM-CP   | GM-CP   |
|              | MODELOS      | 1969  | GM-8  | GM-8  |
|              | MODELOS      | 1973  | GM-8P   | GM-8P   |
|              |              |   | GM-E  | GM-E  |
|              |              |   | GM-EP   | GM-EP   |
|              | MODELOS      | 1970  | GM-9  | GM-9  |
| MODELOS      | 1974         | GM-9P   | GM-9P   |   |
| MODELOS      | 1978         | GM-J  | GM-J  |   |
|              |              | GM-JP   | GM-JP   |   |
| MODELOS      | 1976         | GM-7  | GM-11   |   |
|              |              | GM-7P   | GM-11P  |   |
|              |              | GM-C  | GM-7  |   |
|              |              | GM-CP   | GM-7P   |   |
|              |              |   | GM-C  |   |
|              |              |   | GM-CP   |   |
|              |              |   | GM-D  |   |
|              |              |   | GM-DP   |   |
| MODELOS      | 1977         | GM-8  | GM-12   |   |
|              |              | GM-8P   | GM-12P  |   |
|              |              | GM-E  | GM-8  |   |
|              |              | GM-EP   | GM-8P   |   |
|              |              |   | GM-E  |   |
|              |              |   | GM-EP   |   |
|              |              |   | GM-H  |   |
|              |              |   | GM-HP   |   |
| MODELOS      | 1979         | GM-6  | GM-10   |   |



| MARCA BRAND      | MODELO MODEL |  |  |  |
|------------------|--------------|---|---|---|
| GM (PONTIAC)     |              |   | GM-6P   | GM-10P  |
|                  |              |   | GM-A  | GM-6  |
|                  |              |   | GM-AP   | GM-6P   |
|                  |              |   |   | GM-A  |
|                  |              |   |   | GM-AP   |
|                  |              |   |   | GM-B  |
|                  |              |   |   | GM-BP   |
|                  | MODELOS      | 1980  | GM-7  | GM-11   |
|                  |              |   | GM-7P   | GM-11P  |
|                  |              |   | GM-C  | GM-D  |
|                  |              |   | GM-CP   | GM-DP   |
|                  | MODELOS      | 1981  | GM-8  | GM-12   |
|                  |              |   | GM-8P   | GM-12P  |
|                  |              |   | GM-E  | GM-H  |
|                  |              |   | GM-EP   | GM-HP   |
|                  | MODELOS      | 1982  | GM-9  | GM-13   |
|                  |              |   | GM-9P   | GM-13P  |
|                  |              |   | GM-J  | GM-K  |
|                  |              |   | GM-JP   | GM-KP   |
|                  | MODELOS      | 1983  | GM-6  | GM-10   |
|                  |              | GM-6P   | GM-10P  |   |
|                  |              | GM-A  | GM-B  |   |
|                  |              | GM-AP   | GM-BP   |   |
| MODELOS          | 1984         | GM-6  | GM-10   |   |
| MODELOS          | 1985         | GM-6P   | GM-10P  |   |
|                  |              | GM-7  | GM-7  |   |
|                  |              | GM-7P   | GM-7P   |   |
|                  |              | GM-A  | GM-B  |   |
|                  |              | GM-AP   | GM-BP   |   |
|                  |              | GM-C  | GM-C  |   |
|                  |              | GM-CP   | GM-CP   |   |
| SUNFIRE          | 00-05        | GM-25   | GM-25   |   |
|                  |              | GM-25P  | GM-25P  |   |
| TRANS SPORT      | 1988-1990    | GM-19P  |   |   |
| GM (SATURN)      | SATURN       | 1990-1994   | GM-21   | GM-21   |
|                  |              |   | GM-21P  | GM-21P  |
| HAMOMAG HENSCHEL | F 20         | -   | ME-VA   | ME-VA   |
|                  | F 35         | -   |   |   |
| HOLDEN           | APOLLO       | 1991-   | TOYO-14   | TOYO-14   |
|                  | NOVA         | 1991-   | TOYO-14P  | TOYO-14P  |
|                  | ASTRA        | 1986  | DAT-12  | DAT-12  |
|                  | BARINA       | 1981-1990   | MIT-11  | MIT-11  |
|                  | CAMIRA       | 1980-   | MIT-11P   | MIT-11P   |
|                  | DROVER       | 1981-   | TOYO-14   | TOYO-14   |
|                  | GEMINI       | 1980-1984   | TOYO-14P  | TOYO-14P  |
|                  | JACKAROO     | 1980-   |   |   |
|                  | RODEO        | 1980-   |   |   |
|                  | SHUTTLE      | 1980-   |   |   |
|                  | BARINA       | 1991-1993   | SUZU-10   | SUZU-10   |
|                  |              |   | SUZU-10P  | SUZU-10P  |
|                  | BARINA       | 1994  | OP-S  | OP-S  |
|                  |              |   | OP-SP   | OP-SP   |
|                  | BELMOND      | 1971-1978   | GM-6  | GM-6  |



| MARCA BRAND | MODELO MODEL |  |  |  |
|-------------|--------------|---|---|---|
| HOLDEN      | KINGSWOOD    | 1971-1978   | GM-6P   | GM-6P   |
|             | STATESMAN    | 1972-1978   | GM-A  | GM-A  |
|             | TORANA       | 1971-1972   | GM-AP   | GM-AP   |
|             | BELMOND      | -1979   | GM-42   | GM-42   |
|             | CALAIS       | 1978-   |   |   |
|             | COMMODORE    | 1978-   |   |   |
|             | KINGSWOOD    | 1979-   |   |   |
|             | STATESMAN    | 1978-   |   |   |
|             | CALAIS       | 1993-   | OP-WHP  | OP-WHP  |
|             | COMMODORE    | 1993-   |   |   |
|             | COMMODORE    | 1987-1993   | OP-WHP  | OP-WHP  |
|             |              |   | OP-WYP  | OP-WYP  |
|             | FJ           | -   | HUD-1   | HUD-1   |
|             | GEMINI       | 1985-   | GM-2  | GM-2  |
|             | SPECTRUM     | 1985-   | GM-2P   | GM-2P   |
|             | GEMINI STAT. | 1981-   | MIT-11  | OP-AB   |
|             |              |   | MIT-11P   | OP-ABP  |
|             |              |   | TOYO-14   | OP-BA   |
|             |              |   | TOYO-14P  | OP-BAP  |
|             |              |   |   | OP-J  |
|             |              |   | OP-JP   |   |
| MODELOS     | 1955-1970    | BAS-11  | BAS-11  |   |
| TORANA      | -1971        | BAS-11  | UN-FS   |   |
| HONDA       | ACCORD       | 1976-1980   | HOND-1  | HOND-1  |
|             | CIVIC        | 1973-1976   | HOND-1P   | HOND-1P   |
|             |              |   | HOND-2  | HOND-2  |
|             |              |   | HOND-2P   | HOND-2P   |
|             | ACCORD       | 1981-1982   | HOND-10   | HOND-10   |
|             | ACCORD       | 1984-1990   | HOND-10P  | HOND-10P  |
|             | CITY JAZZ    | 1981-1985   |   |   |
|             | CIVIC        | 1984-1987   |   |   |
|             | PRELUDE      | 1983-1988   |   |   |
|             | PRELUDE      | 1989-1991   |   |   |
|             | QUINTET      | 1981-1983   |   |   |
|             | ACCORD       | 1982-1983   | HOND-10   | HOND-10   |
|             | CIVIC        | 1977-1981   | HOND-10P  | HOND-10P  |
|             |              |   | HOND-11   | HOND-11   |
|             |              |   | HOND-11P  | HOND-11P  |
|             | ACCORD       | 1990-1992   | HOND-14   | HOND-14   |
|             |              |   | HOND-14P  | HOND-14P  |
|             |              |   | HOND-15   | HOND-15   |
|             |              |   | HOND-15P  | HOND-15P  |
|             |              |   | HOND-16D  | HOND-16D  |
|             |              |   | HOND-16DP   | HOND-16DP   |
|             | ACCORD 2 LS  | 1993-1995   | NE-35   | NE-35   |
|             | ACCORD 2 S   | 1993-1995   | NE-35P2   | NE-35P2   |
|             | CIVIC        | 1995  |   |   |
|             | CONCERTO     | 1989-   |   |   |
|             | ACCORD COUPE | 1993-1995   | HOND-14   | HOND-14   |
|             | CIVIC        | 1988-1995   | HOND-14P  | HOND-14P  |
|             | ACCORD EX    | 1991-1995   | HOND-16D  | HOND-16D  |
|             |              |   | HOND-16DP   | HOND-16DP   |
|             | CIVIC        | 1972-1973   | NE-1  | HOND-3D   |



# AUTOMÓVIL - CAMIONETA

## CAR - PICK-UP TRUCKS

| MARCA BRAND        | MODELO MODEL |  |  |  |
|--------------------|--------------|---|---|---|
| HONDA              |              |   | NE-1P   |   |
|                    | CIVIC        | 1982-1983   | HOND-12   | HOND-12   |
|                    | PRELUDE      | 1982  | HOND-12P  | HOND-12P  |
|                    |              |   | HOND-13   | HOND-13   |
|                    |              |   | HOND-13P  | HOND-13P  |
|                    | CIVIC CRX    | 1989-1992   | HOND-14   | HOND-14   |
|                    | CIVIC SHUTLE | 1989-1992   | HOND-14P  | HOND-14P  |
|                    |              |   | HOND-15   | HOND-15   |
|                    |              |   | HOND-15P  | HOND-15P  |
|                    | COUPE        | 1969-1975   | NE-1  |   |
|                    | LIFE         | 1969-1975   | NE-1P   |   |
|                    | N 360        | 1969-1975   |   |   |
|                    | TOURER       | 1969-1975   |   |   |
|                    | PRELUDE      | 1992-1997   | HOND-14   | HOND-14   |
|                    |              |   | HOND-14P  | HOND-14P  |
|                    |              | HOND-16D  | HOND-16D  |   |
|                    |              | HOND-16DP   | HOND-16DP   |   |
| HUMMER             | H2           | 2005-   |   |   |
|                    | H3           | 2005-   |   |   |
| HYUNDAI            | ACCENT       | 1994-1996   | HY-5  | HY-5  |
|                    | EXCEL        | 1994-1995   | HY-5P   | HY-5P   |
|                    | ELANTRA      | 1991-1996   | HY-4  | HY-4  |
|                    | LANTRA       | 1991-1996   | HY-4P   | HY-4P   |
|                    | TIBURON      | 2001  | HY-4P2  | HY-4P2  |
|                    |              |   | HY-4P3  | HY-4P3  |
|                    | EXCEL        | 1986-1989   | HY-3D   | HY-3D   |
|                    |              |   | HY-3DP  | HY-3DP  |
|                    | EXCEL        | 1990-1991   | HY-3D   | HY-3D   |
|                    | PONY         | 1991-   | HY-3DP1   | HY-3DP1   |
|                    | S COUPE      | 1991-1996   |   |   |
|                    | SONATA       | 1991-1996   |   |   |
|                    | PONY         | 1974-1979   | HY-1  | HY-1  |
|                    | PONY         | 1980-1984   | TOYO-14   | TOYO-14   |
|                    |              |   | TOYO-14P  | TOYO-14P  |
|                    | PONY (CAN)   | 1985-1987   | MIT-2I  | MIT-2I  |
|                    |              |   | MIT-2IP   | MIT-2IP   |
|                    | PONY (EU)    | 1985-1987   | HY-2  | HY-2  |
|                    | STELLAR      | 1985-1987   | HY-2P   | HY-2P   |
|                    |              |   | HY-7P   | HY-7P   |
|                    | SONATA       | 1989-1990   | HY-3  | HY-3  |
|                    |              |   | HY-3P2  | HY-3P2  |
|                    | SONATA (USA) | 1993-1995   | HY-6D   | HY-6D   |
| SONICA             | 1993-1995    | HY-6DP  | HY-6DP  |   |
| STAREX             | 1998-        | HY-9P2  | HY-9P2  |   |
| VAN TRANSP.        | 1994-1997    | HY-8  | HY-8  |   |
|                    |              | HY-8P   | HY-8P   |   |
| INFINITI (NIS-SAN) | G 20         | 1992-   | DAT-10  | DAT-10  |
|                    | M 30         | 1992-   | DAT-10P   | DAT-10P   |
|                    |              |   | DAT-7   | DAT-7   |
|                    |              |   | DAT-7P  | DAT-7P  |
|                    |              |   | DAT-7P1   | DAT-7P1   |
|                    | M 30         | 1990-1991   | DAT-13  | DAT-13  |
|                    |              |   | DAT-13P   | DAT-13P   |



| MARCA BRAND        | MODELO MODEL |  |  |  |
|--------------------|--------------|---|---|---|
| INFINITI (NIS-SAN) |              |   | DAT-14  | DAT-14  |
|                    |              |   | DAT-14P   | DAT-14P   |
| INNOCENTI          | 3 CILINDROS  | 1982  |   | AF-10   |
|                    | MINI 650     | 1985  |   | AF-11   |
|                    | MINI DIESEL  | 1984  |   | AF-12   |
|                    | MINI MILLE   | 1980  |   |   |
|                    | MINI TRE     | 1984  |   |   |
|                    | MINI TURBO   | 1983  |   |   |
|                    | 500          | 1986-   | FI-6I   | FI-6I   |
|                    | 650          | 1986-   | FI-6IP  | FI-6IP  |
|                    | 990          | 1986-   |   |   |
|                    | SMALL 500    | 1986-   |   |   |
|                    | SMALL 990    | 1986-   |   |   |
|                    | A40          | -   | UN-FP   | UN-FP   |
|                    | ELBA         | 1992-   | FI-11   | FI-11   |
|                    |              |   | FI-11P  | FI-11P  |
|                    | J 4          | -   | LF-BL   | UN-FS   |
|                    | J 5          | -   | UN-FS   |   |
|                    | JM 3         | -   |   |   |
|                    | MINI 850     | -   |   |   |
|                    | MINI 1000    | 1973  |   |   |
|                    | MINI 1001    | 1973  |   |   |
|                    | MINI COOPER  | 1973  |   |   |
|                    | KORAL 45     | 1990-1992   | FI-6I   | FI-3D   |
|                    | KORAL 55     | 1990-1992   | FI-6IP  | FI-3DP  |
|                    |              |   | FI-3DP5   |   |
| M.COOPER OR.       | -            | STR-2   | STR-2   |   |
| M.MK II 850        | -            | UN-FS   | UN-FS   |   |
| M.DE TOMASO        | 1976         | AF-7I   | AF-10   |   |
| MINI 90            | 1974         | AF-7IP  | AF-11   |   |
| MINI 120           | 1974         |   | AF-12   |   |
| M.METALLICA        | -            | LF-RO   | UN-FS   |   |
| M.T.CLUBMAN        | -            | LF-ROP  |   |   |
| MINI MATIC         | 1970-        | LF-BL   | AF-10   |   |
|                    |              | UN-FS   | AF-11   |   |
|                    |              |   | AF-12   |   |
|                    |              |   | UN-FS   |   |
| REGENT             | -            | LF-BL   | UN-FT   |   |
| INTER. HARVESTER   | T.TERRENO    | -   | GM-6  | GM-10   |
|                    |              |   | GM-6P   | GM-10P  |
|                    |              |   | GM-A  | GM-B  |
|                    |              |   | GM-AP   | GM-BP   |
| IRMSCHER           | VARIOS       | 1940-1975   | KEN-1   | KEN-1   |
|                    | 4.0 I        | -1981   | GM-9  | OP-R  |
|                    |              |   | GM-9P   | OP-RP   |
|                    |              |   | GM-J  | OP-T  |
|                    |              |   | GM-JP   | OP-TP   |
|                    | 4.0 I        | 1981-1986   | OP-R  | OP-R  |
|                    |              |   | OP-RP   | OP-RP   |
|                    |              |   | OP-T  | OP-T  |
|                    |              |   | OP-TP   | OP-TP   |
|                    | 4.0 I        | 1986-   | OP-WHP  | OP-WHP  |
| C.40 E             | -            | OP-WYP  | OP-WYP  |   |



| MARCA BRAND | MODELO MODEL |  |  |  |
|-------------|--------------|---|---|---|
| ISUZU       | AMIGO        | 1988-1991   | GM-4  | GM-4  |
|             | TF           | 1988-1991   | GM-4P   | GM-4P   |
|             |              |   | GM-4P1  | GM-4P1  |
|             | AMIGO        | 1991-1994   | GM-15D  | GM-15D  |
|             | RODEO        | 1991-1994   | GM-15DP   | GM-15DP   |
|             | D-MAX        | 2002-2006   | ISU-3D  | ISU-3D  |
|             | I-290        | 2007  | ISU-3DP   | ISU-3DP   |
|             | I-370        | 2007  |   |   |
|             | I MARK       | 1985-1991   | GM-2  | GM-2  |
|             |              |   | GM-2P   | GM-2P   |
|             | IMPULSE      | 1985-1991   | MIT-2I  | MIT-2I  |
|             | PIAZZA       | 1985-1991   | MIT-2IP   | MIT-2IP   |
|             | TROOPER      | 1985-1991   |   |   |
|             | IMPULSE      | 1992-   | GM-5  | GM-5  |
|             | STYLUS       | 1992-   | GM-5P   | GM-5P   |
|             | MODELOS      | 1981-1984   | MIT-1I  | MIT-1I  |
|             |              |   | MIT-1IP   | MIT-1IP   |
|             | TROOPER      | 1982-1984   | TOYO-14   | TOYO-14   |
|             |              |   | TOYO-14P  | TOYO-14P  |
| TROOPER     | 1991-        | GM-1P   | GM-1P   |   |
| VEHY-CROSS  | 1998-2002    | SUZU-10P  | SUZU-10P  |   |
| JAGUAR      | E            | 1970-1974   | FO-D  | UN-1FS  |
|             |              |   | FO-FR   | UN-FS   |
|             |              |   | FO-FRP  |   |
|             |              |   | WAS-2P  |   |
|             |              |   |   |   |
|             | MAJESTIC     | 1989-1994   | JAU-1P  | JAU-1P  |
|             | SOVEREIGN    | 1989-1994   |   |   |
|             | VANDEN PLAS  | 1989-1994   |   |   |
|             | XJ 6         | 1989-1994   |   |   |
|             | XJS          | 1988-   |   |   |
|             | VANDEN PLAS  | 1988-1989   |   |   |
|             | XJ 6-40      | 1988-1989   |   |   |
|             | XJ 6         | 1971-1975   | FO-D  | IN-4  |
|             |              |   | FO-FR   | UN-1FS  |
|             |              |   | FO-FRP  | UN-FS   |
|             |              |   | WAS-2P  | UN-FT   |
|             | XJ 6         | 1976-1978   | FO-FR   | FO-5  |
|             |              |   | FO-FRP  |   |
|             |              |   | WAS-2P  |   |
|             | XJ 6-12      | 1979-1987   | FO-FR   | CEM-JC  |
| FO-FRP      |              |   |   |   |
| WAS-2P      |              |   |   |   |
| XJS         | 1975         | FO-FR   | UN-FT   |   |
|             |              | FO-FRP  |   |   |
|             |              | WAS-2P  |   |   |
| XJS         | 1976         | FO-FR   | LF-WR   |   |
| XJS         | 1978-1987    | FO-FRP  |   |   |
|             |              | WAS-2P  |   |   |
| XJS         | 1976-1977    | LF-WR   | FO-TC   |   |
| JDM         | ABACA        | 2005-2012   | SIX-3P  | SIX-3P  |
|             | ALBIZIA      | 2003-2012   |   |   |
|             | ALOES        | 2008-2012   |   |   |
|             | ROSDY        | 2012  |   |   |



| MARCA BRAND  | MODELO MODEL |  |  |  |
|--------------|--------------|---|---|---|
| JEEP         | BRIAR WOOD   | 1991-1992   | CHR-9   | CHR-9   |
|              | CHEROKEE     | 1991-1992   | CHR-9P  | CHR-9P  |
|              | COMANCHE     | 1991-1992   |   |   |
|              | LAREDO       | 1991-1992   |   |   |
|              | LTD          | 1991-1992   |   |   |
|              | WRANGLER     | 1991-1992   |   |   |
|              | CHEROKEE     | 1993-1998   | CHR-10  | CHR-10  |
|              | COMANCHE     | 1993-   | CHR-10P   | CHR-10P   |
|              | COUNTRY      | 1993-   |   |   |
|              | G.CHEROKEE   | 1993-1998   |   |   |
|              | G.WAGONEER   | 1993-   |   |   |
|              | LAREDO       | 1993-   |   |   |
|              | LTD          | 1993-   |   |   |
|              | RENEGADE     | 1993-   |   |   |
|              | SAHARA       | 1993-   |   |   |
|              | SPURR        | 1993-   |   |   |
|              | WAGONEER     | 1993-   |   |   |
|              | WRANGLER     | 1993-   |   |   |
|              | COMANCHE     | 1985-1990   | GM-9  |   |
|              | PIONNER      | -1991   | GM-9P   |   |
|              | SCRAMBLER    | 1985-1990   | GM-J  |   |
|              | WAGONEERS    | 1985-1990   | GM-JP   |   |
|              | WRANGLER     | 1985-1990   |   |   |
|              | COMMANDO D   | -   | FEM-3I  | CL-4I   |
|              | RENEGADE     | 1979-1984   | GM-9  | YA-11D  |
|              |              |   | GM-9P   |   |
|              |              |   | GM-J  |   |
|              |              |   | GM-JP   |   |
|              | VARIOS       | 1940-1973   | KEN-1   | KEN-1   |
| JENSEN       | INTERCEPT. 2 | -   | FO-FR   | UN-FS   |
|              | INTERCEPT. 3 | -   | FO-FRP  |   |
| KENWORTH     | VARIOS       | 1950-1987   | KEN-1   | KEN-1   |
|              | VARIOS       | 1960-1986   | HUD-1   | HUD-1   |
| KIA          | CARNIVAL     | 1999-   | KI-3DP  | KI-3DP  |
|              | CLARENCE     | 2001-   |   |   |
|              | CLARUS       | 1998-2001   |   |   |
|              | PRIDE        | 1999-   |   |   |
|              | RIO          | 2001-   |   |   |
|              | SHUMA        | 1998-2000   |   |   |
|              | SORENTO      | 1998-   |   |   |
|              | PRIDE 1.1 L  | 1992-1994   | KI-1D   | KI-1D   |
|              | PRIDE 1.3 LX | 1992-1994   | KI-1DP  | KI-1DP  |
|              | SEPHIA (USA) | 1994-1995   |   |   |
|              | SEPHIA 1.6 I | 1993-1994   |   |   |
|              | SPORTAGE     | 1995-1996   |   |   |
|              | SEPHIA (USA) | 1994-   | KI-1DP1   | KI-1DP1   |
| SPORTAGE USA | 1996-        | KI-2D   | KI-2D   |   |
| LA FORZA     | FORZA 5.0 V8 | 1989-   | GI0B-3P   |   |
| LADA VAZ     | 1200         | 1972-   | NE-3  | IMS-3   |
|              | 1300         | 1972-   | NE-3P   | IMS-3P  |
|              | 1500         | 1972-   | NE-3P1  | IMS-5   |
|              | 1600         | 1972-   | NE-3P2  | IMS-5P  |
|              | 2101         | 1972-   |   |   |



# AUTOMÓVIL - CAMIONETA

## CAR - PICK-UP TRUCKS

| MARCA BRAND | MODELO MODEL |  |  |  |
|-------------|--------------|---|---|---|
| LADA VAZ    | 2102         | 1972-   |   |   |
|             | 2103         | 1972-   |   |   |
|             | 2104         | 1972-   |   |   |
|             | 2105         | 1972-   |   |   |
|             | 2106         | 1972-   |   |   |
|             | 2107         | 1972-   |   |   |
|             | 21011        | 1972-   |   |   |
|             | 21043        | 1972-   |   |   |
|             | 21061        | 1972-   |   |   |
|             | NIVA         | -   |   |   |
|             | RIVA         | -   |   |   |
|             | 3110         | -   | LA-3D   | LA-2  |
|             |              |   | LA-3DP  | LA-2P   |
|             |              |   | LA-4D   |   |
|             |              |   | LA-4DP  |   |
|             | 4x4          | -   | LA-1D   | LA-1D   |
|             | 4x4 G.LARGE  | -   | LA-1DP  | LA-1DP  |
|             | KAMA         | 1984-   | LA-2  | LA-2  |
|             | SAGONA       | -   | LA-2P   | LA-2P   |
|             |              |   | LA-3D   | LA-3D   |
|             |              | LA-3DP  | LA-3DP  |   |
| CARLOTA     | 1991-        | LA-1D   | LA-1D   |   |
| SAMARA      | 1991-1992    | LA-1DP  | LA-1DP  |   |
| NIVA 1.6    | 1992-        | NE-3  | IMS-3   |   |
|             |              | NE-3P   | IMS-3P  |   |
|             |              | NE-3P1  |   |   |
|             |              | NE-3P2  |   |   |
| SAMARA      | 1992-        | LA-3D   | LA-2  |   |
|             |              | LA-3DP  | LA-2P   |   |
| LAMBORGHINI | COUNTACH     | -   | AF-7I   | IMS-3   |
|             | DIABLO COU.  | -   | AF-7IP  | IMS-3P  |
|             | DIABLO ROA.  | -   | AF-7IP1   | IMS-5   |
|             | JALPA        | -   |   | IMS-5P  |
|             | URRACO       | -   |   |   |
|             | ESPADA       | -   | AF-7I   | AF-5I   |
|             |              |   | AF-7IP  | AF-6I   |
|             |              |   | AF-7IP1   |   |
|             | MIURA        | -   | BH-1  | AF-4D   |
|             |              |   | BH-1P   | AF-4I   |
|             |              |   | AF-5D   |   |
|             |              |   | AF-5I   |   |
|             |              |   | AF-6D   |   |
|             |              |   | AF-6I   |   |
| LANCIA      | 2000         | -1972   | GIOB-1D   | GIOB-2I   |
|             | APPIA        | -1972   | GIOB-1DP  | GIOB-2IP  |
|             | FLAVIA       | -1972   |   |   |
|             | FULVIA       | -1972   |   |   |
|             | 2000         | 1972-   | GIOB-1D   | GIOB-2I   |
|             | FULVIA       | 1972-   | GIOB-1DP  | GIOB-2IP  |
|             |              |   | SIP-3   |   |
|             | BETA         | 1972-1982   | AF-7I   | GIOB-3P   |
|             | DELTA        | 1979-1982   | AF-7IP  |   |
|             | GAMMA        | 1972-1982   | FI-9I   |   |



| MARCA BRAND      | MODELO MODEL |  |  |  |
|------------------|--------------|---|---|---|
| LANCIA           |              |   | FI-9IP  |   |
|                  | BETA         | 1975-1980   | AF-7I   | AF-10   |
|                  | MONTECARLO   | 1975-1980   | AF-7IP  | AF-11   |
|                  |              |   |   | AF-12   |
|                  | DEDRA        | 1989-1995   | FI-13   | FI-13   |
|                  | DEDRA S.W.   | 1994  | FI-13P  | FI-13P  |
|                  | DELTA        | 1993-1995   | FI-14P  | FI-14P  |
|                  | DELTA        | 1983  | FI-3D   | GIOB-3P   |
|                  |              |   | FI-3DP  |   |
|                  |              |   | FI-3DP3   |   |
|                  |              |   | FI-6I   |   |
|                  |              |   | FI-6IP  |   |
|                  |              |   | FI-6IP3   |   |
|                  | DELTA        | 1984-1992   | FI-11   | GIOB-3P   |
|                  | PRISMA       | 1984-1989   | FI-11P  |   |
|                  | LANCIA Z     | 1994  | SIX-3P1   | SIX-3P1   |
|                  | Z 2000       | 1994  |   |   |
|                  | MODELOS      | 2000  |   | FI-16P1   |
|                  | THEMA        | 1984-   | FI-10   | FI-10   |
|                  |              |   | FI-10P  | FI-10P  |
|                  |              | FI-11   | FI-11   |   |
|                  |              | FI-11P  | FI-11P  |   |
| TREVI            | 1980-        | FI-9I   | GIOB-3P   |   |
|                  |              | FI-9IP  |   |   |
| LAND-RANGE ROVER | 88           | 1982-1983   | LF-RO   | UN-FS   |
|                  | 88           | 1984  | LF-ROP  |   |
|                  | 109          | 1982-1983   |   |   |
|                  | 109          | 1984  |   |   |
|                  | 110          | 1984-1985   |   |   |
|                  | 88           | 1985-1987   | LF-RO   | AB-6I   |
|                  | 109          | 1985-1987   | LF-ROP  |   |
|                  | 110          | 1986-1987   |   |   |
|                  | SANTANA      | 1985-1987   |   |   |
|                  | 90           | 1985-1986   | LF-RO   | LF-RO   |
|                  | 110          | 1985-1986   | LF-ROP  | LF-ROP  |
|                  | 90           | 1987-1991   | LF-RO   | UN-FT   |
|                  | 110          | 1987-1991   | LF-ROP  |   |
|                  | DEFENDER     | 1990-   |   |   |
|                  | 90 2500      | 1988-1991   | IMS-7   | AB-6I   |
|                  | 90 3500      | 1988-1991   | IMS-7P  |   |
|                  | 110 2500     | 1985-1987   |   |   |
|                  | 110 3500     | 1985-1987   |   |   |
|                  | SANTANA      | 1987-1991   |   |   |
|                  | DISCOVERY    | 1989-1993   | NE-11   | NE-11   |
|                  |              | NE-11P1   | NE-11P1   |   |
|                  |              | NE-11P2   | NE-11P2   |   |
| DISCOVERY        | 1994-1997    | NE-52P  | NE-52P  |   |
| MODELOS          | 1970-1972    | UN-FS   | UN-FP   |   |
| MODELOS          | 1973-1981    | UN-FS   | UN-FS   |   |
| R.ROVER          | -1983        | UN-NH   | UN-NH   |   |
|                  |              | UN-NHP  | UN-NHP  |   |
| R.ROVER          | 1984-1988    | NE-11   | NE-11   |   |
|                  |              | NE-11P  | NE-11P  |   |



| MARCA BRAND      | MODELO MODEL |  |  |  |
|------------------|--------------|---|---|---|
| LAND-RANGE ROVER |              |   | NE-11P  | NE-11P  |
|                  |              |   | NE-11P1   | NE-11P1   |
|                  |              |   | NE-11P2   | NE-11P2   |
|                  |              |   | NE-24   | NE-24   |
|                  |              |   | NE-24P  | NE-24P  |
|                  |              |   | NE-24P1   | NE-24P1   |
|                  | R.ROVER      | 1989-1997   | NE-11   | NE-11   |
|                  |              |   | NE-11P  | NE-11P  |
| LEXUS (TOYOTA)   | 250 ES       | 1989-   | TOYO-18P  | TOYO-18P  |
|                  | 300 ES       | 1989-   |   |   |
|                  | 400 LS       | 1989-   |   |   |
|                  | COUPE 300 SC | 1991-   |   |   |
|                  | COUPE 400 SC | 1991-   |   |   |
| LIGIER           | IXO          | 2010  | SIX-3P  | SIX-3P  |
|                  | JS           | -   |   |   |
|                  | NOVA         | 1999-2004   |   |   |
|                  | OPTIMAX      | 2010  |   |   |
|                  | X-T00        | 2006-2012   |   |   |
| LOTUS            | ECLAT        | -   | TOYO-K1   | TOYO-K1   |
|                  | EXCEL SE     | -   | TOYO-K1P  | TOYO-K1P  |
|                  | ELAN SE      | 1991  | OP-D  | OP-D  |
|                  |              |   | OP-DP   | OP-DP   |
|                  | ESPRIT 2.2   | -   | LF-RO   | UN-FT   |
|                  | ESPRIT COUPE | 1991-   | LF-ROP  |   |
|                  | ESPRIT TURBO | -   |   |   |
|                  | MODELOS      | -1976   | FO-FR   | UN-FS   |
|                  |              |   | FO-FRP  | UN-FT   |
|                  |              |   | LF-RO   |   |
| LF-ROP           |              |   |   |   |
| MACK             | VARIOS       | 1955-1969   | KEN-1   | KEN-1   |
|                  | VARIOS       | 1970-1986   | HUD-1   | HUD-1   |
| MARUTI           | 800          | 1991-1992   | SUZU-7  | SUZU-7  |
|                  | 800 LUXE     | 1991-1992   | SUZU-7P   | SUZU-7P   |
|                  | 800 S.LUXE   | 1991-1992   |   |   |
| MASERATI         | BITURBO      | 1981-   | LF-RO   | AF-10   |
|                  | GHIBLI       | 1986-   | LF-ROP  | AF-11   |
|                  | KARIF        | 1986-   |   | AF-12   |
|                  | QUATTROPORTE | 1976-1986   |   |   |
|                  | SHAMAL       | 1986-   |   |   |
|                  | SPYDER       | 1986-   |   |   |
|                  | BORA         | 1971-1976   | AF-7I   | RO-5D   |
|                  |              |   | AF-7IP  |   |
|                  |              |   | AF-7IP1   |   |
|                  | GHIBLI 5000  | -   |   | IMS-3   |
|                  |              |   |   | IMS-3P  |
|                  | INDY 4900 A. | 1969-   | AF-7I   | GIOB-2I   |
|                  |              |   | AF-7IP  | GIOB-2IP  |
|                  |              |   | AF-7IP1   | RO-5D   |
|                  |              |   |   |   |
| KHAM SIN         | 1972-        | AF-7I   | IMS-3   |   |
|                  |              | AF-7IP  | IMS-3P  |   |
|                  |              | AF-7IP1   | IMS-5   |   |
|                  |              |   |   |   |
|                  |              |   |   |   |



| MARCA BRAND | MODELO MODEL |  |  |  |
|-------------|--------------|---|---|---|
| MASERATI    |              |   |   | IMS-5P  |
|             | KYALAMI      | 1976-   | FO-2  | IMS-5   |
|             |              |   |   | IMS-5P  |
|             | MERAK        | 1972-1976   | CT-3  | RO-5D   |
|             |              |   | CT-3P   |   |
| MAZDA       | 121          | 1988-1990   | MAZ-3D  | MAZ-3D  |
|             | 323          | 1983-1989   | MAZ-6DP   | MAZ-6DP   |
|             | 323 S.W.     | 1986-1996   |   |   |
|             | 626          | 1987-1991   |   |   |
|             | 626 S.W.     | 1986-1992   |   |   |
|             | 727          | 1987-1991   |   |   |
|             | 929 S.W.     | 1982-   |   |   |
|             | COSMO        | 1984-1986   |   |   |
|             | MX6          | 1986-1989   |   |   |
|             | RX7          | 1987-1991   |   |   |
|             | 121          | 1991-1992   | MAZ-5D  | MAZ-5D  |
|             |              |   | MAZ-5DP   | MAZ-5DP   |
|             |              |   | MAZ-7D  | MAZ-7D  |
|             |              |   | MAZ-7DP   | MAZ-7DP   |
|             | 121          | 1993-1994   | MAZ-13D   | MAZ-13D   |
|             |              |   | MAZ-13DP  | MAZ-13DP  |
|             | 323          | 1992-1994   | MAZ-13DP1   | MAZ-13DP1   |
|             | MX3          | 1992-1995   | MAZ-7D  | MAZ-7D  |
|             | MX5          | 1992-1995   | MAZ-7DP   | MAZ-7DP   |
|             | RX7          | 1992-   |   |   |
|             | XEDOS        | 1992-1996   |   |   |
|             | 121          | 1995-   | FO-6P   | FO-6P   |
|             |              |   |   |   |
| 323         | 1977-1982    | MAZ-2D  | MAZ-2D  |   |
| 323 S.W.    | 1977-1986    | MAZ-2DP   | MAZ-2DP   |   |
| 626         | 1978-1982    |   |   |   |
| 929         | 1980-1982    |   |   |   |
| 929 S.W.    | 1980-1982    |   |   |   |
| 323         | 1982-1983    | MAZ-3D  | MAZ-3D  |   |
|             |              | MAZ-3DP   | MAZ-3DP   |   |
|             |              | MAZ-3IP   | MAZ-3IP   |   |
| 323         | 1989-1992    | MAZ-3D  | MAZ-3D  |   |
|             |              | MAZ-7D  | MAZ-7D  |   |
|             |              | MAZ-7DP   | MAZ-7DP   |   |
| 323         | 1995         |   | MAZ-7DP1  |   |
| MX3         | 1995         |   |   |   |
| MX5         | 1995         |   |   |   |
| 323 B.F.    | 1982         | NE-23   | MAZ-2D  |   |
|             |              | NE-26   | MAZ-2DP   |   |
|             |              |   | MAZ-2I  |   |
|             |              |   | MAZ-2IP   |   |
| 323 S.P.    | 1990         | MAZ-7D  | MAZ-7D  |   |
| MPV         | 1989-        | MAZ-7DP   | MAZ-7DP   |   |
| MX5 (EU)    | 1990-1992    |   |   |   |
| MX6         | 1990-1992    |   |   |   |
| 616 CAP.    | -1970        | DAT-3I  | MAZ-2D  |   |
| 616 SNA     | -1970        |   | MAZ-2DP   |   |
| RX2 CAPPE.  | 1970-1971    |   |   |   |
| 616 CAPE.   | 1971-1973    | DAT-11D   | MAZ-2D  |   |



# AUTOMÓVIL - CAMIONETA

## CAR - PICK-UP TRUCKS

| MARCA BRAND | MODELO MODEL |  |  |  |
|-------------|--------------|---|---|---|
| MAZDA       | 618          | 1971-1973   | DAT-11DP  | MAZ-2DP   |
|             | RX2 CAPPE.   | 1974-1977   | WAS-2P  |   |
|             | RX3          | 1974-1977   |   |   |
|             | 626          | 1982-1987   | MAZ-3D  | MAZ-3D  |
|             | 929          | 1982-1986   | MAZ-3DP   | MAZ-3DP   |
|             |              |   | MAZ-3I  | MAZ-3I  |
|             |              |   | MAZ-6DP   | MAZ-6DP   |
|             |              |   | MAZ-6P  | MAZ-6P  |
|             | 626          | 1991  | MAZ-7D  | MAZ-7D  |
|             | MX3          | 1991-1992   | MAZ-7DP   | MAZ-7DP   |
|             |              |   | MAZ-7DP1  | MAZ-7DP1  |
|             | 626          | 1991-1995   | MAZ-13D   | MAZ-13D   |
|             | MX6          | 1992-1995   | MAZ-13DP  | MAZ-13DP  |
|             |              |   | MAZ-13DP1   | MAZ-13DP1   |
|             | 626          | 1995-1997   |   | MAZ-13D   |
|             | MX6          | 1995-1997   |   | MAZ-13DP  |
|             | XEDOS 6      | 1995-1997   |   | MAZ-13DP1   |
|             | 626 GL       | 1981  | CHR-3   | MAZ-2D  |
|             |              |   | NE-22P2   | MAZ-2DP   |
|             | 626 S.W.     | 1993-1996   | MAZ-5D  | MAZ-5D  |
|             | RX7          | 1991  | MAZ-5DP   | MAZ-5DP   |
|             | 808          | 1971-1977   | DAT-11D   | MAZ-2D  |
|             | 818          | 1971-1977   | DAT-11DP  | MAZ-2DP   |
|             | 929          | 1973-1980   | WAS-2P  | MAZ-2I  |
|             |              |   |   | MAZ-2IP   |
|             | 818 1.3      | -1971   | DAT-3I  | MAZ-1I  |
|             | 818 1.5      | -1971   |   |   |
|             | 1800         | 1971-1972   |   |   |
|             | 929 GLX      | 1987-   | MAZ-3D  | MAZ-3D  |
|             | RX7          | 1983-1986   | MAZ-3DP   | MAZ-3DP   |
|             |              |   | MAZ-6DP   | MAZ-6DP   |
|             | 1200         | 1970-1972   | DAT-11D   | MAZ-1I  |
|             | 1800         | 1970-1971   | DAT-11DP  |   |
|             |              |   | WAS-2P  |   |
|             | 1600         | 1972-   | DAT-3I  | MAZ-1D  |
|             | R 100        | 1970-1971   |   |   |
|             | ARTIS        | -   | MAZ-21DP1   | MAZ-21DP1   |
|             | B 1800       | 1970-1971   | MAZ-1I  | MAZ-1I  |
|             | COSMO        | 1975-1979   | MAZ-16  | MAZ-16  |
|             | COSMO        | 1980  | MAZ-3D  | MAZ-3D  |
| GLC 323     | 1983-1989    | MAZ-3DP   | MAZ-3DP   |   |
| COSMO       | 1982-1983    | MAZ-3D  | MAZ-3D  |   |
|             |              | MAZ-3DP   | MAZ-3DP   |   |
|             |              | MAZ-3I  | MAZ-3I  |   |
|             |              | MAZ-6P  | MAZ-6P  |   |
| E 1600      | 1986         | MAZ-2D  | MAZ-2D  |   |
|             |              | MAZ-2DP   | MAZ-2DP   |   |
|             |              | MAZ-2I  | MAZ-2I  |   |
|             |              | MAZ-2IP   | MAZ-2IP   |   |
|             |              | MAZ-3D  | MAZ-3D  |   |
|             |              | MAZ-3DP   | MAZ-3DP   |   |
|             |              | MAZ-3I  | MAZ-3I  |   |
|             |              | MAZ-3IP   | MAZ-3IP   |   |

| MARCA BRAND | MODELO MODEL |  |  |  |
|-------------|--------------|---|---|---|
| MAZDA       | EUNOS 800    | 1993-   | TOYO-18P  | TOYO-18P  |
|             | XEDOS 9      | 1993-1996   |   |   |
|             | MIATA        | 1989-1992   | MAZ-3D  | MAZ-3D  |
|             | MX5          | 1989-1992   | MAZ-7D  | MAZ-7D  |
|             |              |   | MAZ-7DP   | MAZ-7DP   |
|             |              |   | MAZ-7DP1  | MAZ-7DP1  |
|             | MODELOS      | 1970-1974   | MAZ-14D   | MAZ-14D   |
|             | MODELOS      | 1975-1984   | MAZ-1D  | MAZ-2D  |
|             |              |   | MAZ-1I  | MAZ-2DP   |
|             |              |   |   | MAZ-2I  |
|             |              |   |   | MAZ-2IP   |
|             | NAVAJO       | 1991-   | MAZ-8D  | MAZ-8D  |
|             |              |   | MAZ-8DP   | MAZ-8DP   |
|             | R 100        | 1972-   | DAT-11D   | MAZ-1D  |
|             | R 1200       | 1972-   | DAT-11DP  |   |
|             |              |   | WAS-2P  |   |
|             | RX2          | 1972-1973   | DAT-11D   | MAZ-2I  |
|             |              |   | DAT-11DP  | MAZ-2IP   |
|             |              |   | WAS-2P  |   |
|             | RX4 LUCE     | 1972-1978   | MAZ-2D  | MAZ-2D  |
| RX5 COSMO   | 1972-1978    | MAZ-2DP   | MAZ-2DP   |   |
| RX7 COUPE   | 1972-1978    | MAZ-2I  | MAZ-2I  |   |
|             |              | MAZ-2IP   | MAZ-2IP   |   |
| MERCEDES    | 180C         | 1993-   | ME-7P   | ME-7P   |
|             | 200C         | 1993-   | ME-8P   | ME-8P   |
|             | 220C         | 1993-   |   |   |
|             | 280C         | 1993-   |   |   |
|             | 300C         | 1993-   |   |   |
|             | 190          | 1984-1986   | ME-10P  | ME-10P  |
|             | 200          | 1984-   | ME-2P   | ME-2P   |
|             | 230          | 1984-   | ME-3P   | ME-3P   |
|             | 250          | 1984-   | ME-4P   | ME-4P   |
|             | 260          | 1984-   | ME-5P   | ME-5P   |
|             | 280          | 1979-   | ME-6P   | ME-6P   |
|             | 300          | 1980-   |   |   |
|             | 360          | 1984-   |   |   |
|             | 380          | 1979-   |   |   |
|             | 420          | 1984-   |   |   |
|             | 450          | 1979-   |   |   |
|             | 500          | 1979-   |   |   |
|             | 560          | 1984-   |   |   |
|             | 1000         | 1984-   |   |   |
|             | 190          | 1986-   | ME-4P   | ME-4P   |
|             |              |   | ME-5P   | ME-5P   |
|             | 190 ALARM    | 1986-1992   | ME-10P  | ME-10P  |
|             |              |   | ME-11P  | ME-11P  |
|             |              |   | ME-12P  | ME-12P  |
| 200         | 1973-1974    | ME-HD   | ME-HD   |   |
| 220         | 1973-1974    | ME-HDP  | ME-HDP  |   |
| 230         | 1973-1974    | ME-HF   | ME-HF   |   |
| 240D        | 1973-1976    | ME-HFP  | ME-HFP  |   |
| 250         | 1973-1977    | ME-HM   | ME-HM   |   |
| 280         | 1973-1974    | ME-HMP  | ME-HMP  |   |



| MARCA BRAND | MODELO MODEL |  |  |  |
|-------------|--------------|---|---|---|
| MERCEDES    | 350          | 1973-   | ME-HZ   | ME-HZ   |
|             | 380          | 1973-1977   | ME-HZP  | ME-HZP  |
|             | 450          | 1973-1979   |   |   |
|             | 200          | 1974-1975   | ME-HD   | ME-HD   |
|             | 220          | 1974-   | ME-HDP  | ME-HDP  |
|             | 230          | 1974-1977   | ME-HZ   | ME-HZ   |
|             | 240          | 1974-1977   | ME-HZP  | ME-HZP  |
|             | 280          | 1974-1979   |   |   |
|             | 200          | 1975-1976   | ME-HF   | ME-HF   |
|             |              |   | ME-HFP  | ME-HFP  |
|             |              |   | ME-HM   | ME-HM   |
|             |              |   | ME-HMP  | ME-HMP  |
|             | 200          | 1976-1977   | ME-HU   | ME-HU   |
|             | 240D         | 1976-   | ME-HUP  | ME-HUP  |
|             | 300D         | 1976-   | ME-NU   | ME-NU   |
|             |              |   | ME-NUP  | ME-NUP  |
|             | 200          | 1977-1984   | ME-HU   | ME-HU   |
|             | 230          | 1977-1984   | ME-HUP  | ME-HUP  |
|             | 240          | 1977-   | ME-HY   | ME-HY   |
|             | 250          | 1977-1984   | ME-HYP  | ME-HYP  |
|             | 300          | 1977-1980   | ME-NU   | ME-NU   |
|             | 380          | 1977-1979   | ME-NUP  | ME-NUP  |
|             |              |   | ME-NY   | ME-NY   |
|             |              |   | ME-NYP  | ME-NYP  |
|             | 206D         | -   | ME-VA   | ME-VA   |
|             | 306D         | -   |   |   |
|             | 207D         | -1992   | ME-HM   | ME-HM   |
|             | 207F         | -1992   | ME-HMP  | ME-HMP  |
|             | 207K         | -1992   |   |   |
|             | 208D         | -1992   |   |   |
|             | 209D         | -1992   |   |   |
|             | 307D         | -1992   |   |   |
|             | 308D         | 1992-   |   |   |
|             | L 508        | -1991   |   |   |
|             | L 608        | -1991   |   |   |
|             | LN 914       | -1991   |   |   |
|             | MB 308DT     | -1991   |   |   |
|             | MB 408DT     | -1991   |   |   |
|             | U 900        | -1991   |   |   |
|             | U 1700       | -1991   |   |   |
|             | 220          | -1972   | ME-HF   | ME-HF   |
|             | 230          | -1972   | ME-HFP  | ME-HFP  |
|             | 250          | -1972   | ME-HZ   | ME-HZ   |
|             | 280          | -1972   | ME-HZP  | ME-HZP  |
|             | 300          | -1972   |   |   |
| 350         | -1972        |   |   |   |
| 7200        | -1972        |   |   |   |
| 230         | -            | ME-HF   | ME-HF   |   |
| 240         | -            | ME-HFP  | ME-HFP  |   |
| 280         | -            | ME-HM   | ME-HM   |   |
| 300         | -            | ME-HMP  | ME-HMP  |   |
| TODO T. 4WD | -            | ME-HZ   | ME-HZ   |   |
|             |              | ME-HZP  | ME-HZP  |   |

| MARCA BRAND | MODELO MODEL |  |  |  |        |
|-------------|--------------|---|---|---|--------|
| MERCEDES    | 400          | -1994   | ME-2P   | ME-2P   |        |
|             | 600          | -1994   | ME-3P   | ME-3P   |        |
|             | 711          | 1996-   | ME-HMP  | ME-HMP  |        |
|             | 814          | 1996-   |   |   |        |
|             | 817          | 1996-   |   |   |        |
|             | 917          | 1996-   |   |   |        |
|             | 1117         | 1996-   |   |   |        |
|             | 1300         | 1996-   |   |   |        |
|             | 1500         | 1996-   |   |   |        |
|             | SPRINTER     | 1996-   |   |   |        |
|             | VARIO        | 1996-   |   |   |        |
|             | MB 100D      | -1994   | ME-1  | ME-1  |        |
|             |              |   | ME-1P   | ME-1P   |        |
|             | MODELOS      | -1970   | NE-61D  |   |        |
|             |              |   | NE-62   |   |        |
|             | VITO         | 1996-   | ME-HMP  | ME-HMP  |        |
|             |              |   | ME-HZ   | ME-HZ   |        |
|             |              |   | ME-HZP  | ME-HZP  |        |
|             | VITO         | 1997-   | ME-HMLP   | ME-HMLP   |        |
|             | MG           | MG  | 1970-1974   | UN-NH   | UN-FS  |
|             |              | MGB   | 1970-1974   | UN-NHP  |        |
|             |              | MGB GT  | 1970-1975   |   |        |
|             |              | MG  | 1975-1977   | NE-1  | UN-FS  |
|             |              | MGB   | 1975-1978   | NE-1P   |        |
|             |              | MG  | 1978-   | NE-10   | UN-FS  |
|             |              |   | NE-10P  | UN-FS   |        |
| MGF         |              | 1997  | NE-10P  | NE-10P  |        |
| MODELOS     |              | -1970   | UN-FP   | UN-FP   |        |
|             |              |   | UN-FS   | UN-FS   |        |
| MICROCAR    |              | FAMILY  | 2007-2009   | SIX-3P  | SIX-3P |
|             |              | M.GO  | 2009  |   |        |
|             | NEWSTREET    | 2008  |   |   |        |
|             | PRATIC       | 2008  |   |   |        |
|             | VIRGO        | 2008  |   |   |        |
| MITSUBISHI  | 3000 GT/R/SL | -   | MIT-12  | MIT-12  |        |
|             | BRAVO        | -   | MIT-7   | MIT-7   |        |
|             | CHARIOT      | 1987-   | MIT-7P  | MIT-7P  |        |
|             | COLT         | 1987-1993   |   |   |        |
|             | DIAMANTE     | 1992-   |   |   |        |
|             | ECLIPSE      | 1987-   |   |   |        |
|             | ETERNA       | 1989-   |   |   |        |
|             | EXPO         | -   |   |   |        |
|             | GALANT       | 1987-1996   |   |   |        |
|             | L 200        | 1987-   |   |   |        |
|             | L 300        | 1987-   |   |   |        |
|             | LANCER       | 1987-1996   |   |   |        |
|             | MINICAB      | 1987-   |   |   |        |
|             | MIRAGE       | 1987-1993   |   |   |        |
|             | MONTERO      | 1992-1996   |   |   |        |
|             | MX SUPER A.R | -   |   |   |        |
|             | NIMBUS       | 1987-   |   |   |        |
|             | PAJERO       | 1992-1996   |   |   |        |
| S.RUNNER    | 1992-1998    |   |   |   |        |









# AUTOMÓVIL - CAMIONETA

## CAR - PICK-UP TRUCKS

| MARCA BRAND | MODELO MODEL |  |  |  |
|-------------|--------------|---|---|---|
| MITSUBISHI  | SHOGUN       | -   |   |   |
|             | SPACE GEAR   | 1995  |   |   |
|             | SPACE WAGON  | 1985-   |   |   |
|             | CANTER       | 1997  | MIT-15P   | MIT-15P   |
|             | CELESTE      | 1972-1980   | MIT-11  | MIT-11  |
|             | COLT         | 1972-1980   | MIT-11P   | MIT-11P   |
|             | GALANT       | 1972-1980   |   |   |
|             | LAMBDA       | 1972-1980   |   |   |
|             | LANCER       | 1972-1980   |   |   |
|             | MINICA       | 1972-1980   |   |   |
|             | STARION      | 1972-1980   |   |   |
|             | COLT         | 1981-1984   | MIT-21  | MIT-21  |
|             | CORDIA       | 1981-1984   | MIT-21P   | MIT-21P   |
|             | DEBONAIR     | 1981-1984   |   |   |
|             | ETERNA       | 1981-1983   |   |   |
|             | GALANT       | 1981-1983   |   |   |
|             | L 300        | -1983   |   |   |
|             | L 300 VAN    | 1981-1984   |   |   |
|             | LANCER       | 1981-1983   |   |   |
|             | MINICA       | 1981-1983   |   |   |
|             | MONTERO      | 1981-1992   |   |   |
|             | PAJERO       | 1981-1992   |   |   |
|             | SAPPORO      | 1981-1984   |   |   |
|             | SHOGUN       | 1981-1984   |   |   |
|             | SIGMA        | 1981-1984   |   |   |
|             | SPACE WAGON  | 1981-1983   |   |   |
|             | STARION      | 1981-1983   |   |   |
|             | VISTA        | -1993   |   |   |
|             | COLT         | 1984-1987   | MIT-3   | MIT-3   |
|             | DEBONAIR     | 1983-1985   | MIT-3P  | MIT-3P  |
|             | ETERNA       | 1983-1989   | MIT-4   | MIT-4   |
|             | GALANT       | 1983-1987   | MIT-4P  | MIT-4P  |
|             | L 300        | 1983-1987   |   |   |
|             | LANCER       | 1983-1987   |   |   |
|             | MINICA       | 1983-1987   |   |   |
|             | ORCHID       | 1983-1985   |   |   |
|             | SPACE WAGON  | 1983-1985   |   |   |
|             | STARION      | 1983-1985   |   |   |
|             | TREDIA       | 1983-1985   |   |   |
|             | COLT         | 1993-1996   | MIT-13D   | MIT-13D   |
|             | MIRAGE       | 1993-   | MIT-14D   | MIT-14D   |
|             |              |   | MIT-8D  | MIT-8D  |
|             |              |   | MIT-8DP   | MIT-8DP   |
|             | INTERCOOLER  | 1992-   | CHR-17  | CHR-17  |
|             |              | MIT-12  | MIT-12  |   |
|             |              | MIT-7   | MIT-7   |   |
|             |              | MIT-7P  | MIT-7P  |   |
| L 400       | 1997-        | MIT-7P  | MIT-7P  |   |
| MODELOS     | 1985-1986    | MIT-5   | MIT-5   |   |
|             |              | MIT-5P  | MIT-5P  |   |
|             |              | MIT-6   | MIT-6   |   |
|             |              | MIT-6P  | MIT-6P  |   |
| PRECIS      | 1986-        | HY-3D   | HY-3D   |   |



| MARCA BRAND | MODELO MODEL |  |  |  |       |
|-------------|--------------|---|---|---|-------|
| MITSUBISHI  |              |   | HY-3DP1   | HY-3DP1   |       |
|             | SUMMIT       | 1993-   | MIT-8D  | MIT-8D  |       |
|             | VISTA        | 1993-   | MIT-8DP   | MIT-8DP   |       |
|             | MOSKVITCH    | 408   | -   | NE-3  | MOS-1 |
|             |              | 412   | -   | NE-3P   | VOL-3 |
|             |              | 426   | -   | NE-3P1  |       |
|             |              | 427   | -   | NE-3P2  |       |
|             |              | 2135  | -   |   |       |
|             |              | 2136  | -   |   |       |
|             |              | 2137  | -   |   |       |
| 2138        |              | -   |   |   |       |
| 2140        |              | -   |   |   |       |
| 2141 ALEKO  |              | -   | LA-3D   | LA-3D   |       |
|             |              | LA-3DP  | LA-3DP  |   |       |
| NISSAN      | 200 SX       | -1983   | DAT-12  | DAT-12  |       |
|             | 240 Z        | -1983   | DAT-6   | DAT-6   |       |
|             | 280 Z        | -1983   | DAT-6P  | DAT-6P  |       |
|             | 300 L        | -1983   | DAT-7   | DAT-7   |       |
|             | 300 ZX       | -1983   | DAT-7P  | DAT-7P  |       |
|             | AUSTER       | -1983   |   |   |       |
|             | AXXESS       | -1983   |   |   |       |
|             | BLUEBIRD     | -1983   |   |   |       |
|             | CEDRIC       | -1983   |   |   |       |
|             | CHERRY       | -1983   |   |   |       |
|             | EXA          | -1983   |   |   |       |
|             | FAIRLADY     | -1983   |   |   |       |
|             | GAZELLE      | -1983   |   |   |       |
|             | GLORIA       | -1983   |   |   |       |
|             | LANGLEY      | -1983   |   |   |       |
|             | LAUREL       | -1983   |   |   |       |
|             | LEOPARD      | -1983   |   |   |       |
|             | LIBERTA VIL. | -1983   |   |   |       |
|             | MARCH        | -1983   |   |   |       |
|             | MAXIMA       | -1983   |   |   |       |
|             | MICRA        | -1983   |   |   |       |
|             | PAO          | -1983   |   |   |       |
|             | PINTARA      | -1983   |   |   |       |
|             | PRAIRE       | -1983   |   |   |       |
|             | PRESIDENT    | -1983   |   |   |       |
|             | PULSAR       | -1983   |   |   |       |
|             | SENTRA       | -1983   |   |   |       |
|             | SILVIA       | -1983   |   |   |       |
|             | SKYLINE      | -1983   |   |   |       |
|             | STANZA       | -1983   |   |   |       |
|             | SUNNY        | 1983-1989   |   |   |       |
|             | TULIP        | -1983   |   |   |       |
|             | VANETTE      | -1983   |   |   |       |
|             | VIOLET       | -1983   |   |   |       |
| 240 Z       | 1969-1973    | DAT-5D  | DAT-1D  |   |       |
| 280 Z       | 1969-1973    |   | DAT-1DP   |   |       |
| BLUEBIRD    | 1977-1979    |   |   |   |       |
| CHERRY      | 1977-1979    |   |   |   |       |
| SENTRA      | 1977-1979    |   |   |   |       |



| MARCA BRAND | MODELO MODEL |  |  |  |
|-------------|--------------|---|---|---|
| NISSAN      | SKYLINE      | 1977-1979   |   |   |
|             | SUNNY        | 1977-1979   |   |   |
|             | VIOLET       | 1977-1979   |   |   |
|             | 240 Z        | 1974-1983   | DAT-5D  | DAT-2D  |
|             | 260 Z        | 1974-1983   |   | DAT-2DP   |
|             | 280 Z        | 1974-1983   |   | DAT-2I  |
|             | 280 ZX ST.W  | 1974-1983   |   | DAT-2IP   |
|             | 1200 DE LUXE | -1971   |   | DAT-4I  |
|             | 1200 VAN     | -1971   |   |   |
|             | 1200 DE LUXE | 1971-1972   | DAT-8   | DAT-7   |
|             |              |   | DAT-8P  | DAT-7P  |
|             | BLUEBIRD     | 1970-1976   | DAT-5D  | DAT-8   |
|             | CHERRY       | 1970-1976   |   | DAT-8I  |
|             | SENTRA       | 1970-1976   |   | DAT-8IP   |
|             | SKYLINE      | 1970-1976   |   | DAT-8IP1  |
|             | SUNNY        | 1970-1976   |   | DAT-8P  |
|             | VIOLET       | 1970-1976   |   |   |
|             | BLUEBIRD     | 1976-1979   | DAT-1D  | DAT-1D  |
|             |              |   | DAT-1DP   | DAT-1DP   |
|             |              |   | DAT-1I  | DAT-1I  |
|             |              |   | DAT-1IP   | DAT-1IP   |
|             | BLUEBIRD     | 1980-1982   | DAT-9D  | DAT-9D  |
|             |              |   | DAT-9DP   | DAT-9DP   |
|             |              |   | DAT-9I  | DAT-9I  |
|             |              |   | DAT-9IP   | DAT-9IP   |
|             | CEDRIC       | 1995-1997   | DAT-15  | DAT-15  |
|             | GLORIA       | 1995-1997   | DAT-15P   | DAT-15P   |
|             | PATHFINDER   | 1996-1997   | DAT-16  | DAT-16  |
|             | CHERRY       | 1980-1982   | NE-11   | DAT-1D  |
|             |              |   | NE-11P  | DAT-1DP   |
|             |              |   |   | DAT-1I  |
|             |              |   |   | DAT-1IP   |
|             | FLORIDA      | 1989-1991   | DAT-6   | DAT-6   |
|             | PATROL 4x4   | 1986-   | DAT-6P  | DAT-6P  |
|             | SUNNY        | 1989-1991   |   |   |
|             | TERRANO      | 1989-1995   |   |   |
|             | TRADE        | 1989-   |   |   |
|             | MAXIMA       | 1980-1982   | DAT-2D  | DAT-2D  |
|             |              |   | DAT-2DP   | DAT-2DP   |
|             |              |   | DAT-2I  | DAT-2I  |
|             |              | DAT-2IP   | DAT-2IP   |   |
| MAXIMA      | 1991-1995    | DAT-10  | DAT-7   |   |
|             |              | DAT-10P   |   |   |
| MICRA       | 1993-1995    | DAT-10  | DAT-10  |   |
| PRIMERA     | 1991-1995    | DAT-10P   | DAT-10P   |   |
| TERRANO     | 1995         |   |   |   |
| TERRANO II  | 1993-1995    |   |   |   |
| PATHFINDER  | 1991-        | DAT-12  | DAT-12  |   |
| SENTRA      | 1991-        |   |   |   |
| PATROL 4 WD | -1985        | DAT-8   | DAT-8   |   |
|             |              | DAT-8P  | DAT-8P  |   |
| QUEST       | 1993-        | FO-8D   | FO-8D   |   |
|             |              | FO-8DP  | FO-8DP  |   |



| MARCA BRAND  | MODELO MODEL       |  |  |  |        |
|--------------|--------------------|---|---|---|--------|
| NISSAN       |                    |   | FO-8DP1   | FO-8DP1   |        |
|              | QUEST              | 1993-1994   | DAT-19  | DAT-19  |        |
|              |                    |   | DAT-19P   | DAT-19P   |        |
|              | QUEST              | 1996  | DAT-20  | DAT-20  |        |
|              |                    |   | DAT-20P   | DAT-20P   |        |
|              | SERENA             | 1993-1996   | DAT-6   | DAT-6   |        |
|              |                    |   | DAT-6P1   | DAT-6P1   |        |
|              | URVAN              | -1994   | DAT-12  | DAT-12  |        |
|              |                    |   |   | DAT-1D  |        |
|              |                    |   |   | DAT-1DP   |        |
|              | VANETTE            | 1983-1996   | DAT-12  | DAT-12  |        |
|              |                    |   | DAT-6   | DAT-6   |        |
|              |                    |   | DAT-6P  | DAT-6P  |        |
|              | NISSAN (AUSTRALIA) | PINTARA   | -1983   | DAT-12  | DAT-12 |
|              |                    | PULSAR  | -1983   | DAT-6   | DAT-6  |
|              |                    |   | DAT-6P  | DAT-6P  |        |
|              |                    |   | DAT-7   | DAT-7   |        |
|              |                    |   | DAT-7P  | DAT-7P  |        |
| NISSAN (USA) | 810                | 1980-1982   | DAT-2D  | DAT-2D  |        |
|              |                    |   | DAT-2DP   | DAT-2DP   |        |
|              |                    |   | DAT-2I  | DAT-2I  |        |
|              |                    |   | DAT-2IP   | DAT-2IP   |        |
|              | 810                | 1983-   | DAT-12  | DAT-12  |        |
|              |                    |   | DAT-6   | DAT-6   |        |
|              |                    |   | DAT-6P  | DAT-6P  |        |
|              |                    |   | DAT-7   | DAT-7   |        |
|              |                    |   | DAT-7P  | DAT-7P  |        |
| NSU          | RO 80              | -   |   |   |        |
| OM IVECO     | 40                 | -   | AF-9D   | AF-5D   |        |
|              |                    |   | AF-9DP  | AF-5I   |        |
|              |                    |   | AF-9I   | AF-6D   |        |
|              |                    |   | AF-9IP  | AF-6I   |        |
|              | 50.10              | 1979-1981   | LF-RO   | IMS-3   |        |
|              | 60.10              | 1979-1981   | LF-ROP  | IMS-3P  |        |
|              | 65.10              | 1979  |   | IMS-5   |        |
|              | 70.10              | 1979  |   | IMS-5P  |        |
|              | 50.10              | 1981  | SIP-1   | IMS-3   |        |
|              | 60.10              | 1981  |   | IMS-3P  |        |
|              | 70.10              | 1981  |   | IMS-5   |        |
|              | 75.10              | 1981  |   | IMS-5P  |        |
|              | 79.10              | 1981  |   |   |        |
|              | 79.13              | 1981  |   |   |        |
|              | 75                 | -   | AF-9D   | FI-5D   |        |
|              |                    |   | AF-9DP  | FI-5I   |        |
|              |                    |   | AF-9I   | IMS-3   |        |
|              |                    |   | AF-9IP  | IMS-3P  |        |
|              |                    |   | FEM-1D  | IMS-5   |        |
|              |                    |   | FEM-1I  | IMS-5P  |        |
|              | 100.13             | -   | AF-8D   | IMS-3   |        |
|              | 160                | -   | AF-8DP  | IMS-3P  |        |
|              | 160.26             | -   | AF-8I   | IMS-5   |        |
|              |                    |   | AF-8IP  | IMS-5P  |        |
|              |                    |   | AF-9D   |   |        |



# AUTOMÓVIL - CAMIONETA

## CAR - PICK-UP TRUCKS

| MARCA BRAND   | MODELO MODEL |  |  |  |
|---------------|--------------|---|---|---|
| OM IVECO      |              |   | AF-9DP  |   |
|               |              |   | AF-9I   |   |
|               |              |   | AF-9IP  |   |
|               | 100.13       | -1978   | AF-9D   | IMS-3   |
|               | 110.110P     | -1978   | AF-9DP  | IMS-3P  |
|               | 110.13       | -1978   | AF-9I   | IMS-5   |
|               | 130          | -1978   | AF-9IP  | IMS-5P  |
|               |              |   | FEM-1D  |   |
|               |              |   | FEM-1I  |   |
|               | 130          | -   | FEM-1D  | IMS-3   |
|               | 130 R        | -   | FEM-1I  | IMS-3P  |
|               | 130 R/H      | -   |   | IMS-5   |
|               | 130 T/H      | -   |   | IMS-5P  |
|               | 150 R20      | -   | AF-9D   | FI-5D   |
|               | 150 T20      | -   | AF-9DP  | FI-5I   |
|               | 150.20       | -   | AF-9I   | IMS-3   |
|               | 159.20       | -   | AF-9IP  | IMS-3P  |
|               | 190 T30      | -   |   | IMS-5   |
|               | 190.30       | -   |   | IMS-5P  |
|               | 190.35       | -   | AF-7I   | IMS-3   |
|               | 190.38       | -   | AF-7IP  | IMS-3P  |
|               | 190.38 TUR.  | -   | AF-9D   | IMS-5   |
|               |              |   | AF-9DP  | IMS-5P  |
|               |              |   | AF-9I   |   |
|               |              |   | AF-9IP  |   |
|               | 330.26       | -   | VO-VB   | IMS-3   |
|               | 330.35       | -   | VO-VBP  | IMS-3P  |
|               |              |   |   | IMS-5   |
|               |              |   |   | IMS-5P  |
|               | DAINO 145    | -   | BH-4  | AF-5D   |
|               | LUPETTO      | -   |   | AF-5I   |
|               |              |   |   | AF-6D   |
|               |              |   |   | AF-6I   |
|               | GRINTA       | -   | AF-7I   | IMS-3   |
|               |              |   | AF-7IP  | IMS-3P  |
|               |              |   | FI-9I   | IMS-5   |
|               |              |   | FI-9IP  | IMS-5P  |
|               |              |   | LF-RO   |   |
|               |              |   | LF-ROP  |   |
|               | LEONCINO     | -   | BH-4  | AF-4D   |
|               |              |   | AF-4I   |   |
| ORSETTO       | -            | FEM-1D  | AF-5D   |   |
|               |              | FEM-1I  | AF-5I   |   |
|               |              |   | AF-6D   |   |
|               |              |   | AF-6I   |   |
| OPEL-VAUXHALL | ADMIRAL      | -1973   | OP-6  | OP-6  |
|               | KADETT       | -1973   | OP-7  | OP-7  |
|               | OLIMPIYA     | -1973   | OP-8  | OP-8  |
|               | REKORD       | -1973   | OP-9  | OP-9  |
|               |              |   | OP-BB   | OP-BB   |
|               |              |   | OP-EE   | OP-EE   |
|               |              |   | OP-FF   | OP-FF   |
|               | ASCONA       | -1974   | OP-HA   | OP-HA   |



| MARCA BRAND   | MODELO MODEL |  |  |  |
|---------------|--------------|---|---|---|
| OPEL-VAUXHALL | MANTA        | -1974   | OP-HB   | OP-HB   |
|               |              |   | OP-HG   | OP-HG   |
|               |              |   | OP-HH   | OP-HH   |
|               | ASCONA       | 1975-1981   | OP-AB   | OP-AB   |
|               | KADETT       | 1973-1983   | OP-ABP  | OP-ABP  |
|               | MANTA        | 1975-1981   | OP-BA   | OP-BA   |
|               |              |   | OP-BAP  | OP-BAP  |
|               |              |   | OP-J  | OP-J  |
|               |              |   | OP-JP   | OP-JP   |
|               | ASCONA       | 1982-   | OP-WHP  | OP-WHP  |
|               | CALIBRA      | 1987-1995   | OP-WYP  | OP-WYP  |
|               | CARAVAN      | 1992-   |   |   |
|               | COMMODORE    | 1982-   |   |   |
|               | MANTA        | 1982-   |   |   |
|               | MONZA        | 1984-   |   |   |
|               | OMEGA        | 1987-1995   |   |   |
|               | REKORD       | 1984-   |   |   |
|               | VECTRA       | 1987-1995   |   |   |
|               | ASTRA        | 1991-1995   | OP-D  | OP-D  |
|               | CORSA        | 1984-1995   | OP-DP   | OP-DP   |
|               | CORSA VAN    | 1984-1995   | OP-S  | OP-S  |
|               | KADETT       | 1984-   | OP-SP   | OP-SP   |
|               | ASTRA VAN    | 1991-1995   | OP-D  | OP-D  |
|               | COMBO        | -   | OP-DP   | OP-DP   |
|               | FRONTERA     | 1992-1996   | GM-4  | GM-4  |
|               | MONTERREY    | 1992-   | GM-4P   | GM-4P   |
|               |              |   | GM-4P1  | GM-4P1  |
|               | MANTA 1.8    | 1975-1979   | OP-J  | OP-J  |
|               |              |   | OP-JP   | OP-JP   |
|               | MIDI         | 1992-   | MIT-3   | MIT-3   |
|               |              |   | MIT-3P  | MIT-3P  |
|               | MONZA        | 1974-1981   | OP-R  | OP-R  |
|               | REKORD       | 1974-1984   | OP-RP   | OP-RP   |
|               | SENATOR      | 1984-   | OP-T  | OP-T  |
|               |              |   | OP-TP   | OP-TP   |
|               | MONZA        | 1981-1984   | GM-9  | OP-R  |
|               | SENATOR      | 1981-1984   | GM-9P   | OP-RP   |
|               |              |   | GM-J  | OP-T  |
|               |              |   | GM-JP   | OP-TP   |
|               | TIGRA        | 1994  | OP-SP1  | OP-SP1  |
| PEUGEOT       | 104          | 1972  | LMP-1   | VA-6  |
|               |              |   | LMP-1P  | VA-6P   |
|               |              |   | NE-4  |   |
|               |              |   | NE-4P   |   |
|               |              |   | NE-4P1  |   |
|               | 104          | 1978  | NE-4  | NE-4  |
|               | 504          | 1975-   | NE-4P   | NE-4P   |
|               | 604          | 1975-1980   | NE-4P1  | NE-4P1  |
|               | 104          | 1979  | LMP-2   | LAS-V   |
|               |              |   | LMP-2P  | VA-6  |
|               |              | NE-4  | VA-6P   |   |
|               |              | NE-4P   |   |   |



| MARCA BRAND | MODELO MODEL |  |  |  |
|-------------|--------------|---|---|---|
| PEUGEOT     |              |   | NE-4P1  |   |
|             | 104          | 1980  | CHR-3   | CHR-3   |
|             | 104          | 1982-   | CHR-3P  | CHR-3P  |
|             | 305          | 1978-1980   | NE-22P1   | NE-22P1   |
|             | 305          | 1983-1987   |   |   |
|             | 505          | 1979-1980   |   |   |
|             | 505 BREAK    | 1981-1983   |   |   |
|             | 604          | 1981-   |   |   |
|             | 104          | 1981  | LMP-4   | LMP-4   |
|             | 505 BERLINA  | 1981-1983   | LMP-4P  | LMP-4P  |
|             |              |   | LMP-5   | LMP-5   |
|             |              |   | LMP-5P  | LMP-5P  |
|             | 106          | 1991-1997   | NE-36   | NE-36   |
|             |              |   | NE-36P1   | NE-36P1   |
|             | 106 SERVICE  | -1993   | NE-19   | NE-19   |
|             | 205 SERVICE  | -1993   | NE-20P1   | NE-20P1   |
|             | 309 SERVICE  | 1985-   |   |   |
|             | 405 AFFAIRE  | 1987-1991   |   |   |
|             | 204          | 1965-   | NE-37   | VA-6  |
|             | 304          | 1969-1978   | NE-37P  | VA-6P   |
|             | 404          | 1965-   | NE-4  |   |
|             | 504 BERLINA  | 1968-1974   | NE-4P   |   |
|             |              |   | NE-4P1  |   |
|             | 205          | 1984  | NE-20   | NE-20   |
|             |              |   | NE-20P  | NE-20P  |
|             |              |   | NE-29   | NE-29   |
|             |              |   | NE-29P  | NE-29P  |
|             | 205          | 1985-1991   | NE-20   | NE-20   |
|             | 505          | 1985-   | NE-20P1   | NE-20P1   |
|             |              |   | NE-29   | NE-29   |
|             | 205          | 1991-1993   | NE-20   | NE-20   |
|             | 405          | 1991-1993   | NE-20P1   | NE-20P1   |
|             |              |   | NE-29   | NE-29   |
|             |              |   | NE-36   | NE-36   |
|             |              |   | NE-36P1   | NE-36P1   |
|             | 205          | 1993-   | NE-20P2   | NE-20P2   |
|             | 405          | 1993-   | NE-36   | NE-36   |
|             |              |   | NE-36P1   | NE-36P1   |
|             |              |   |   |   |
|             | 305          | 1981-1982   | SIX-1   | SIX-1   |
|             |              |   | SIX-1P1   | SIX-1P1   |
|             | 305 SERVICE  | 1983-   | CHR-3   | CHR-3   |
|             |              |   | NE-22P1   | NE-22P1   |
|             | 306          | 1993-1997   | NE-20P2   | NE-20P2   |
|             |              |   | NE-36   | NE-36   |
| 309         | 1985-        | NE-20   | NE-20   |   |
| 405         | 1987-1991    | NE-20P1   | NE-20P1   |   |
|             |              | NE-29   | NE-29   |   |
|             |              | NE-29P  | NE-29P  |   |
| 406         | 1995-1997    | NE-51P2   | NE-51P2   |   |
| 504 BREAK   | 1968-1974    | NE-4  | RO-11D  |   |
|             |              | NE-4P   |   |   |
|             |              | NE-4P1  |   |   |



| MARCA BRAND       | MODELO MODEL |  |  |  |
|-------------------|--------------|---|---|---|
| PEUGEOT           | 504 PICK UP  | 1975-   | NE-4  | NE-4  |
|                   |              |   | NE-4P1  | NE-4P1  |
|                   | 505          | 1984  | NE-20   | NE-20   |
|                   |              |   | NE-20P  | NE-20P  |
|                   | 505 SERVICE  | 1979-   | CHR-3   | LAS-R   |
|                   |              |   | NE-22P1   | LAS-V   |
|                   | 605          | 1990-   | NE-34P  | NE-34P  |
|                   | 806          | 1994  | SIX-3P1   | SIX-3P1   |
|                   | EXPERT       | 1995-1996   |   |   |
|                   | J-5          | -   | FI-12   | FI-12   |
|                   |              |   | FI-12P3   | FI-12P3   |
|                   |              |   | FI-3D   | FI-3D   |
|                   |              |   | FI-3DP3   | FI-3DP3   |
|                   |              |   | FI-6I   | FI-6I   |
|                   | J-7          | -   | FI-6IP3   | FI-6IP3   |
|                   |              |   | NE-4  |   |
|                   |              |   | NE-4P1  |   |
|                   | J-9          | -   | NE-4  | RO-4D   |
|                   |              |   | NE-4P1  | RO-4I   |
|                   |              |   |   | RO-5D   |
|                   |              |   |   | RO-5I   |
|                   | PARTNER      | 1997  | SIX-3P1   | SIX-3P1   |
| RANCH             | 1997         | SIX-3P2   | SIX-3P2   |   |
| PEUGEOT (AR-GEN.) | 404          | -   | NE-3  | NE-43   |
|                   |              |   | NE-3P   |   |
|                   |              |   | NE-3P2  |   |
| 405               | -            | NE-20   | NE-20   |   |
|                   |              | NE-20P1   | NE-20P1   |   |
| 504               | -            | NE-3  | NE-3  |   |
|                   |              | NE-3P   | NE-3P   |   |
|                   |              | NE-3P2  | NE-3P2  |   |
|                   |              | NE-4  | NE-4  |   |
|                   |              | NE-4P   | NE-4P   |   |
| 504 PICK UP       | -            | NE-4  | NE-4  |   |
|                   |              | NE-4P   | NE-4P   |   |
| 505               | -            | NE-20   | NE-20   |   |
|                   |              | NE-20P1   | NE-20P1   |   |
|                   |              | NE-42   | NE-42   |   |
|                   |              | NE-42P  | NE-42P  |   |
|                   |              | NE-42P1   | NE-42P1   |   |
| PIAGGIO           | PORTER       | 1993-1994   | DAI-1P  | DAI-1P  |
| PORSCHE           | 911 CARRERA  | 1970-   | PO-HC   | PO-HC   |
|                   | 912          | 1970-   | PO-HCP  | PO-HCP  |
|                   | 914          | 1970-   | PO-NC   | PO-NC   |
|                   |              |   | PO-NCP  | PO-NCP  |
|                   | 924          | 1975-1993   | VO-HV   | VO-HV   |
|                   | 944          | 1975-1993   | VO-HVP  | VO-HVP  |
|                   |              |   | VO-VB   | VO-VB   |
|                   |              |   | VO-VBP  | VO-VBP  |
|                   | 928          | 1977-   | PO-1P   | PO-1P   |
|                   |              |   | PO-2P   | PO-2P   |



# AUTOMÓVIL - CAMIONETA

## CAR - PICK-UP TRUCKS

| MARCA BRAND     | MODELO MODEL |  |  |  |        |        |
|-----------------|--------------|---|---|---|--------|--------|
| PORSCHE         | 968          | 1993-   | AU-AH   | AU-AH   |        |        |
|                 |              |   | VO-AHP  | VO-AHP  |        |        |
| PREMIER         | 118 NE       | -   | AF-7I   | IMS-3   |        |        |
|                 |              |   | AF-7IP  | IMS-3P  |        |        |
|                 |              |   | AF-9D   | IMS-5   |        |        |
|                 |              |   | AF-9DP  | IMS-5P  |        |        |
|                 |              |   | FEM-1D  |   |        |        |
|                 |              |   | FEM-1I  |   |        |        |
|                 |              |   | FEM-2D  |   |        |        |
|                 |              |   | FEM-2I  |   |        |        |
|                 |              |   | FO-FR   |   |        |        |
|                 |              |   | FO-FRP  |   |        |        |
|                 |              |   | SIP-2   |   |        |        |
|                 |              |   | PADMINI   | -   | FEM-1D | AF-4D  |
|                 |              |   |   |   | FEM-1I | AF-4I  |
|                 |              |   |   |   | FEM-2D | AF-5D  |
|                 |              |   |   |   | FEM-2I | AF-5I  |
|                 |              |   | AF-6D   |   |        |        |
|                 |              |   | AF-6I   |   |        |        |
| RAYTON FIS-SORE | MAGNUM 4x4   | -   | FI-1  | FI-1  |        |        |
|                 |              |   | MAGNUM 4x4TD  | -   | FI-11  | FI-11  |
|                 |              |   |   |   | FI-11P | FI-11P |
|                 |              |   |   |   | FI-1P  | FI-1P  |
|                 |              |   |   |   |        |        |
|                 | MAGNUM FORZA | -   | GIQB-3P   | GIQB-3P   |        |        |
| RENAULT         | R 4          | 1961-1991   | NE-4  | NE-4  |        |        |
|                 |              |   | NE-4P   | NE-4P   |        |        |
|                 |              |   | NE-4P1  | NE-4P1  |        |        |
|                 |              |   | NE-4P2  | NE-4P2  |        |        |
|                 | R 5          | 1972-1979   | LMP-2   | RO-15   |        |        |
|                 |              |   | LMP-2P  | VA-7  |        |        |
|                 |              |   | NE-15D  |   |        |        |
|                 |              |   | NE-15DP   |   |        |        |
|                 |              |   | NE-15I  |   |        |        |
|                 | R 5          | 1979  | NE-15D  | NE-16   |        |        |
|                 |              |   | NE-15DP   | NE-59P  |        |        |
|                 |              |   | NE-15I  |   |        |        |
|                 |              |   | NE-15IP   |   |        |        |
|                 | R 5          | 1980  |   |   |        |        |
|                 | R 5          | 1981  | CHR-3   | VA-10   |        |        |
|                 | R 5          | 1983-1984   | CHR-3P  |   |        |        |
|                 | R 5          | 1982  | CHR-3   | VA-10   |        |        |
|                 |              |   | CHR-3P  |   |        |        |
|                 |              |   | LMP-4   |   |        |        |
|                 |              |   | LMP-4P1   |   |        |        |
|                 |              |   | LMP-5   |   |        |        |
|                 |              |   | LMP-5P1   |   |        |        |
|                 | R 5          | 1985-1986   | NE-19   | VA-10   |        |        |
|                 |              | NE-19P1   |   |   |        |        |
| R 5             | 1986-        | NE-19   | NE-28   |   |        |        |



| MARCA BRAND | MODELO MODEL |  |  |  |
|-------------|--------------|---|---|---|
| RENAULT     |              |   | NE-19P1   |   |
|             | R 6          | 1968-   | LMP-1   | RO-15   |
|             |              |   | LMP-1P  |   |
|             |              |   | NE-15I  |   |
|             |              |   | NE-15IP   |   |
|             | R 7          | -   | NE-15I  | NE-16   |
|             |              |   | NE-15IP   | NE-4  |
|             |              |   | NE-4  | NE-4P2  |
|             |              |   | NE-4P2  | NE-59P  |
|             | R 9          | 1981  | CHR-3   | NE-16   |
|             | R 11         | 1981  | CHR-3P  | NE-59P  |
|             |              |   | LMP-5   |   |
|             |              |   | LMP-5P1   |   |
|             | R 9          | 1982-1983   | CHR-3   | BS-5  |
|             | R 11         | 1982-1983   | CHR-3P  | NE-16   |
|             |              |   |   | NE-59P  |
|             |              |   |   | VA-10   |
|             | R 9          | 1984-   | NE-19   | NE-16   |
|             | R 11         | 1984-   | NE-19P  | NE-59P  |
|             |              |   |   | VA-10   |
|             |              |   |   | VA-17P  |
|             | R 12         | 1969-1971   | LMP-1   | RO-15   |
|             |              |   | LMP-1P  |   |
|             | R 12         | 1972-   | LMP-2   | VA-7  |
|             |              |   | LMP-2P  |   |
|             | R 14         | 1976-1977   | CHR-3   | NE-16   |
|             |              |   | CHR-3P  | NE-59P  |
|             |              |   | NE-15I  |   |
|             |              |   | NE-15IP   |   |
|             | R 14         | 1978-1979   | CHR-3   | VA-7  |
|             |              |   | CHR-3P  |   |
|             | R 14         | 1980-   | CHR-3   | NE-16   |
|             |              |   | CHR-3P  | NE-59P  |
|             |              | LMP-4   | VA-10   |   |
|             |              | LMP-4P1   |   |   |
|             |              | LMP-5   |   |   |
|             |              | LMP-5P1   |   |   |
| R 15        | 1971-        | NE-15I  | RO-15   |   |
| R 17        | 1971-        | NE-15IP   |   |   |
| R 16        | 1965-        | NE-3  | RO-15   |   |
|             |              | NE-3P1  |   |   |
|             |              | NE-3P2  |   |   |
| R 18        | 1978-1980    | CHR-3   | NE-16   |   |
| FUEGO       | 1978-1980    | CHR-3P  | NE-59P  |   |
| R 18        | 1980-1982    | CHR-3   | VA-10   |   |
| FUEGO       | 1982-        | CHR-3P  |   |   |
|             |              | LMP-5   |   |   |
|             |              | LMP-5P1   |   |   |
| R 18        | 1983-        | CHR-3   | VA-10   |   |
|             |              | CHR-3P  |   |   |
|             |              | NE-19   |   |   |
|             |              | NE-19P1   |   |   |
|             |              | NE-22P  |   |   |



| MARCA BRAND               | MODELO MODEL |  |  |  |
|---------------------------|--------------|---|---|---|
| RENAULT                   | R 19         | 1988-1990   | NE-19   | NE-19   |
|                           | ALPINE       | 1992-   | NE-19P1   | NE-19P1   |
|                           | R 19         | 1990-   | NE-19   | NE-19   |
|                           |              |   | NE-19P1   | NE-19P1   |
|                           |              |   | NE-36   | NE-36   |
|                           |              |   | NE-36P1   | NE-36P1   |
|                           | R 20         | 1975-   | CHR-3   | VA-17P  |
|                           | R 30         | 1975-   | CHR-3P  |   |
|                           |              |   | LMP-4   |   |
|                           |              |   | LMP-4P1   |   |
|                           |              |   | NE-22P  |   |
|                           | R 21         | 1986-1989   | NE-19   | NE-28   |
|                           |              |   | NE-19P1   | VA-10   |
|                           | R 21         | 1990-1991   | NE-36   | NE-36   |
|                           |              |   | NE-36P1   | NE-36P1   |
|                           | R 21         | 1992-   | NE-38   | NE-38   |
|                           | R 25         | 1992-   | NE-38P1   | NE-38P1   |
|                           | COACH        | 1995-1996   |   |   |
|                           | MEGANE       | 1995-1996   |   |   |
|                           | SAFRANE      | 1992-1995   |   |   |
|                           | R 25         | 1983-1988   | NE-19   | VA-17P  |
|                           |              |   | NE-19P1   |   |
|                           | R 25         | 1989-1991   | NE-36   | VA-17P  |
|                           |              |   | NE-36P1   |   |
|                           | CLIO         | 1990-1998   | NE-36   | NE-36   |
|                           |              |   | NE-36P1   | NE-36P1   |
|                           |              |   | VA-34   | VA-34   |
| VA-34P                    |              |   | VA-34P  |   |
| ESPACE                    | 1984-1997    | NE-19   | VA-10   |   |
|                           |              | NE-19P1   |   |   |
|                           |              | NE-36   |   |   |
|                           |              | NE-36P1   |   |   |
| LAGUNA                    | 1994         | NE-38   | NE-38   |   |
|                           |              | NE-38P1   | NE-38P1   |   |
|                           |              | VA-34   | VA-34   |   |
|                           |              | VA-34P  | VA-34P  |   |
| LAGUNA                    | 1994-1995    | VA-34P1   | VA-34P1   |   |
| LAGUNA 2 <sup>o</sup> se. | 1994         | VA-34   | NE-50P  |   |
| TWINGO                    | 1993-1994    | NE-36   | NE-36   |   |
|                           |              | NE-36P  | NE-36P  |   |
|                           |              | NE-36P  | NE-36P  |   |
| TWINGO                    | 1995         | NE-36P  | NE-36P  |   |
|                           |              | VA-34P1   | VA-34P1   |   |
| RENAULT (ARGEN.)          | FUEGO        | -   | CHR-3   | NE-16   |
|                           | R11          | -   | NE-22P  | NE-59P  |
|                           | R18          | -   |   |   |
|                           | NEVADA       | -   | CHR-3   | NE-28   |
|                           |              |   | NE-22P  |   |
|                           | R 4          | -   | NE-3  | NE-3  |
|                           |              |   | NE-3P   | NE-3P   |
| NE-3P2                    |              |   | NE-3P2  |   |
| NE-4                      |              |   | NE-4  |   |
|                           |              |   |   |   |



| MARCA BRAND      | MODELO MODEL |  |  |  |       |
|------------------|--------------|---|---|---|-------|
| RENAULT (ARGEN.) |              |   | NE-4P   | NE-4P   |       |
|                  |              |   | NE-4P2  | NE-4P2  |       |
|                  | R 6          | -   | NE-3  | NE-3  |       |
|                  |              |   | NE-3P   | NE-3P   |       |
|                  |              |   | NE-3P2  | NE-3P2  |       |
|                  | R12          | -   | CHR-3   | CHR-3   |       |
|                  |              |   | NE-22P  | NE-22P  |       |
|                  |              |   | NE-4  | NE-4  |       |
|                  |              |   | NE-4P   | NE-4P   |       |
|                  | R19          | -   | NE-4P2  | NE-4P2  |       |
|                  |              |   | NE-36   | NE-36   |       |
| R21              | -            | NE-36P1   | NE-36P1   |   |       |
|                  |              | CHR-3   | NE-28   |   |       |
| TRAFFIC          | -            | NE-22P  | VA-10   |   |       |
|                  |              | CHR-3   | NE-16   |   |       |
| RENAULT SAVIEM   |              |   | NE-22P  | NE-53   |       |
|                  |              |   | NE-59P  |   |       |
|                  | B 70.35      | -1987   | CHR-3   | VA-7  |       |
|                  | B 70.45      | -1987   | CHR-3P  |   |       |
|                  | B 90.35      | -1987   | LMP-5   |   |       |
|                  | MASTER P35 D | -1987   | LMP-5P1   |   |       |
|                  | MASTER T30 D | -1987   | NE-22P  |   |       |
|                  | MASTER T35 D | -1987   |   |   |       |
|                  | B 70.45      | 1988-1992   | CHR-3   | NE-28   |       |
|                  | B 80.45      | 1992-   | NE-22P  |   |       |
|                  | B 90.45      | 1988-1992   |   |   |       |
|                  | B 90.50      | 1988-1992   |   |   |       |
|                  | B 110.150    | 1992-   |   |   |       |
|                  | B 110.35     | 1992-   |   |   |       |
|                  | MASTER T30 D | 1987-   |   |   |       |
|                  | MASTER T35 D | 1987-   |   |   |       |
|                  | MASTER TURBO | 1987-   |   |   |       |
| EXPRESS-B-D      | -1987        | NE-19   | NE-19   |   |       |
|                  |              | NE-19P  | NE-19P  |   |       |
|                  |              | NE-19P1   | NE-19P1   |   |       |
|                  |              | EXPRESS-B-D   | 1987-1991   | NE-19   | NE-28 |
|                  |              | SUPERCINCO D  | -1991   | NE-19P1   |       |
|                  |              | JK 50-60  | -   | BH-1  | RO-15 |
|                  |              | JK 75-90  | -   | BH-1P   | RO-4D |
|                  |              | JK 110-115  | -   |   | RO-4I |
|                  |              | JP 11   | -   | BH-1  | RO-4D |
|                  |              | JP 13   | -   | BH-1P   | RO-4I |
| JP 13 TU         | -            |   |   |   |       |
| JP 115           | -            |   |   |   |       |
| R 11 CARGO       | -1991        | NE-19   | VA-10   |   |       |
|                  |              | NE-19P1   |   |   |       |
| R 19 TD          | -1992        | NE-19   | NE-19   |   |       |
|                  |              | NE-19P1   | NE-19P1   |   |       |
| R4 F4 C. 850     | -1994        | NE-4  | NE-4  |   |       |
| R4 F4 C.1100     | -1994        | NE-4P   | NE-4P   |   |       |
|                  |              | NE-4P2  | NE-4P2  |   |       |
| TRAFFIC          | -1987        | CHR-3   | RO-17   |   |       |



# AUTOMÓVIL - CAMIONETA

## CAR - PICK-UP TRUCKS

| MARCA BRAND    | MODELO MODEL |  |  |  |
|----------------|--------------|---|---|---|
| RENAULT SAVIEM |              |   | CHR-3P  |   |
|                |              |   | NE-22P  |   |
|                | TRAFFIC      | 1988-   | NE-19   | NE-28   |
|                |              |   | NE-19P  |   |
| ROLLS ROYCE    | ALGUNOS-SOME | 1995  | YA-20D  | YA-20D  |
|                | CLOUD        | -1970   |   |   |
|                | SHADOW       | -1970   |   |   |
|                | CLOUD        | 1981-1997   | YA-21I  | YA-21I  |
|                | SHADOW       | 1981-1997   |   |   |
|                | MODELOS      | 1970-1973   | YA-18D  | YA-18D  |
|                |              |   | YA-19D  | YA-19D  |
|                |              |   | YA-20I  | YA-20I  |
|                | SHADOW       | 1971-1980   | YA-21I  | YA-20D  |
|                | SPIRIT       | 1971-1980   |   | YA-20I  |
|                | SPUR         | 1971-1980   |   |   |
|                | WRAITH       | 1971-1980   |   |   |
|                | SPIRIT       | 1980-1983   | YA-20I  | YA-20I  |
| SPUR           | 1980-1983    | YA-21I  | YA-21I  |   |
| ROVER          | 2000         | 1976-1981   | LF-RO   | LF-RO   |
|                | 2000         | 1985-   | LF-ROP  | LF-ROP  |
|                | 2300         | 1976-1981   |   |   |
|                | 2300         | 1985-   |   |   |
|                | 2400         | 1976-1981   |   |   |
|                | 2400         | 1985-   |   |   |
|                | 2600         | 1976-1981   |   |   |
|                | 2600         | 1985-   |   |   |
|                | 3500         | 1976-1981   |   |   |
|                | 2000         | 1982-1985   | LF-RO   | LF-RO   |
|                | 2200         | 1982-1985   | LF-ROP  | LF-ROP  |
|                | 2300         | 1982-1985   | NE-11   | NE-11   |
|                | 2400         | 1982-1985   | NE-11P  | NE-11P  |
|                | 2600         | 1982-1985   |   |   |
|                | 3500         | 1982-1985   |   |   |
|                | 2000 SC/TC   | 1963-1975   | LF-9  | UN-4  |
|                | 3500         | 1963-1975   |   |   |
|                | 25           | 2000-   | NE-35P2   | NE-35P2   |
|                | 416          | 1995-1996   |   |   |
|                | 620          | 1995-1996   |   |   |
|                | 3500 V8 S    | 1976-   | LF-9  | UN-1FS  |
|                |              |   | LF-RO   | UN-4  |
|                |              |   | LF-ROP  |   |
|                | 820          | 1992-1994   | NE-52P  | NE-52P  |
|                | 825          | 1992-1994   |   |   |
|                | ALLEGRO      | 1973-   | LF-RO   | UN-FT   |
|                |              |   | LF-ROP  |   |
| ALLEGRO 2      | 1973-        | LF-BL   | UN-FT   |   |
|                |              | LF-RO   |   |   |
|                |              | LF-ROP  |   |   |
| ALLEGRO 3      | 1973-        | LF-BL   | UN-FT   |   |
|                |              | LF-RO   |   |   |
|                |              | LF-ROP  |   |   |
|                |              | NE-11   |   |   |
|                |              | NE-11P  |   |   |

| MARCA BRAND | MODELO MODEL |  |  |  |
|-------------|--------------|---|---|---|
| ROVER       | FX 4S (TAXI) | -   | LF-BL   | IN-4  |
|             |              |   | LF-RO   | IN-5  |
|             |              |   | LF-ROP  |   |
|             | MAESTRO      | 1983-   | NE-11   | NE-11   |
|             | SERIE 200    | 1985-1989   | NE-11P  | NE-11P  |
|             | SERIE 800    | 1987-1991   | NE-11P1   | NE-11P1   |
|             |              |   | NE-11P2   | NE-11P2   |
|             |              |   | NE-24   | NE-24   |
|             |              |   | NE-24P  | NE-24P  |
|             |              |   | NE-24P1   | NE-24P1   |
|             | MARINA       | -   | LF-BL   | UN-FT   |
|             |              |   | LF-RO   |   |
|             |              |   | LF-ROP  |   |
|             |              |   | NE-1  |   |
|             |              |   | NE-1P   |   |
|             | MAXI         | 1969-   | NE-1  | UN-FS   |
|             | TRAVELLER    | 1969-   | NE-1P   |   |
|             | METRO        | 1980-1983   | NE-11   | NE-14   |
|             | METRO        | 1984-1989   | NE-11P  |   |
|             | MINI         | 1959-1973   | UN-FS   | UN-FS   |
|             | MINI         | 1974-1984   | LF-BL   | UN-FS   |
|             |              |   | LF-RO   |   |
|             |              |   | LF-ROP  |   |
|             | MINI         | 1985-   | NE-11   | UN-FS   |
|             |              |   | NE-11P1   |   |
|             |              |   | NE-11P2   |   |
|             | MONTEGO      | 1984-1988   | NE-11   | NE-14   |
|             |              |   | NE-11P  |   |
|             |              |   | NE-24   |   |
|             |              |   | NE-24P  |   |
|             | MONTEGO      | 1988-1991   | NE-11   | NE-11   |
|             |              |   | NE-11P1   | NE-11P1   |
|             |              |   | NE-11P2   | NE-11P2   |
|             |              | NE-24   | NE-24   |   |
|             |              | NE-24P1   | NE-24P1   |   |
| MONTEGO     | 1992-        | NE-35   | NE-35   |   |
|             |              | NE-35P  | NE-35P  |   |
| PRINCESS    | -            | NE-11   | LF-RO   |   |
|             |              | NE-11P  | LF-ROP  |   |
| SERIE 100   | 1991-1993    | NE-11   | NE-11   |   |
|             |              | NE-11P1   | NE-11P1   |   |
|             |              | NE-11P2   | NE-11P2   |   |
| SERIE 200   | 1984         | HOND-10   | HOND-10   |   |
|             |              | HOND-10P  | HOND-10P  |   |
| SERIE 200   | 1989-1993    | NE-35   | NE-35   |   |
| SERIE 400   | 1989-1993    | NE-35P2   | NE-35P2   |   |
| SHERPA 185  | -            | LF-BL   | UN-1FS  |   |
| SHERPA 230  | -            | LF-RO   | UN-FT   |   |
| SHERPA 255  | -            | LF-ROP  |   |   |
| SAAB        | 93           | 1998  | SAA-1P1   | SAA-1P1   |
|             | 900          | 1993-   |   |   |
|             | 9000         | 1986-   |   |   |
|             | 95           | -   | AS-1D   | SAA-AC  |



| MARCA BRAND | MODELO MODEL |  |  |  |
|-------------|--------------|---|---|---|
| SAAB        | 96           | -   | SAA-AC<br>SAA-ACP   | SAA-ACP   |
|             | 99           | 1974-1977   | SAA-2P  | SAA-2P  |
|             | 900          | 1974-1977   |   |   |
|             | 900          | 1978-1993   | SAA-AC<br>SAA-ACP   | SAA-AC<br>SAA-ACP   |
| SEAT        | 124          | 1970-   | FI-9I<br>FI-9IP   | IMS-3<br>IMS-3P<br>IMS-5<br>IMS-5P  |
|             | 127          | 1972-   | FI-9I   | IMS-3   |
|             | 131          | 1972-1975   | FI-9IP  | IMS-3P  |
|             |              |   | IMS-7   | IMS-5   |
|             |              |   | IMS-7P  | IMS-5P  |
|             |              |   | SIP-3   |   |
|             | 131          | 1975-   | CL-7P   | CL-7P   |
|             |              |   | FI-2D   | FI-3D   |
|             |              |   | FI-2DP3   | FI-3DP  |
|             |              |   | FI-3D<br>FI-3DP   |   |
|             | 132          | 1973-   | AF-7I   | IMS-3   |
|             |              |   | AF-7IP  | IMS-3P  |
|             |              |   | FI-8I   | IMS-5   |
|             |              |   | FI-8IP  | IMS-5P  |
|             |              |   | FO-FR   |   |
|             |              |   | FO-FRP  |   |
|             | CORDOBA      | 1993-1995   | AU-AH   | AU-AH   |
|             | EMELBA       | 1993-   | AU-AHP  | AU-AHP  |
|             | IBIZA        | 1993-1995   | SE-AHP  | SE-AHP  |
|             | POKER        | 1993-   | VO-2  | VO-2  |
|             | TOLEDO       | 1991-1995   | VO-2P   | VO-2P   |
|             | EMELBA       | 1984-1987   | CL-6  | CL-6  |
|             | GREDOS (GRE) | -   | CL-6P   | CL-6P   |
|             | IBIZA        | 1984-1987   |   |   |
|             | MALAGA       | 1985-1990   |   |   |
|             | POKER        | 1984-1987   |   |   |
| RONDA       | 1985-        |   |   |   |
| EMELBA      | 1988-1992    | AU-HV   | AU-HV   |   |
| IBIZA       | 1988-1992    | CL-9P   | CL-9P   |   |
| POKER       | 1988-1992    | VO-HV   | VO-HV   |   |
| FURA        | 1972-1982    | CL-7P   | IMS-3   |   |
|             |              | FI-3D   | IMS-3P  |   |
|             |              | FI-3DP  | IMS-5   |   |
|             |              | FI-8I   | IMS-5P  |   |
|             |              | FI-8IP  |   |   |
|             |              | IMS-7<br>IMS-7P   |   |   |
| MARBELLA    | 1987-1992    | CL-6  | IMS-3   |   |
| TERRA       | -            | CL-6P   | IMS-3P  |   |
|             |              |   | IMS-5   |   |
|             |              |   | IMS-5P  |   |
| MARBELLA    | 1993-1997    | AU-AH   | AU-AH   |   |



| MARCA BRAND | MODELO MODEL |  |  |  |
|-------------|--------------|---|---|---|
| SEAT        |              |   | AU-AHP  | AU-AHP  |
|             |              |   | CL-6  | CL-6  |
|             |              |   | CL-6P   | CL-6P   |
|             |              |   | SE-AHP  | SE-AHP  |
|             |              |   | VO-2  | VO-2  |
|             |              |   | VO-2P   | VO-2P   |
|             | PANDA        | 1980-1986   | FI-8I   | IMS-3   |
|             |              |   | FI-8IP  | IMS-3P  |
|             |              |   | FI-9I   | IMS-5   |
|             |              |   | FI-9IP  | IMS-5P  |
|             | RITMO        | -   | CL-7P   | CL-7P   |
| RONDA       | 1982-1984    | FI-3D   | FI-3D   |   |
|             |              | FI-3DP  | FI-3DP  |   |
| TRANS       | -            | CL-6  | IMS-3   |   |
|             |              | CL-6P   | IMS-3P  |   |
|             |              | FI-9I   | IMS-5   |   |
|             |              | FI-9IP  | IMS-5P  |   |
| SKODA       | 100          | 1982-1984   | SKO-1   |   |
|             | 105          | 1982-1984   | SKO-1P  |   |
|             | 110          | 1982-1984   | SKO-2   |   |
|             | 120          | 1982-1984   |   |   |
|             | 110          | 1985-   | SKO-1   |   |
|             | 120          | 1985-   | SKO-1P  |   |
|             | 130          | 1985-   |   |   |
|             | 135          | 1985-   |   |   |
|             | ESTELLE      | 1985-   |   |   |
|             | GARD LUXE    | 1985-   |   |   |
|             | RAPIDE       | 1985-   |   |   |
| FAVORIT     | 1987-        | SKO-3I  | SKO-3I  |   |
| FORMAN      | 1987-        | SKO-3IP   | SKO-3IP   |   |
| SILVER      | 1993-        |   |   |   |
| FELICIA     | 1995         | SKO-5P  | SKO-5P  |   |
| PICK-UP     | 1995         |   |   |   |
| MODELOS     | 1964-1981    | SKO-8   | SKO-4   |   |
| SSANGYONG   | KORANDO      | 2000-   | HY-5  | HY-5  |
|             |              |   | HY-5P   | HY-5P   |
|             |              |   | HY-3P2  | HY-3P2  |
| STERLING    | SERIE 800    | -   | NE-11   |   |
|             |              |   | NE-11P  |   |
|             |              |   | NE-24   |   |
|             |              |   | NE-24P  |   |
| STEYR-PUCH  | 19 S31       | -1994   | NE-58D  |   |
|             | 19 S37       | -1994   |   |   |
|             | 26 S31       | -1994   |   |   |
|             | 32 S31       | -1994   |   |   |
|             | 230          | -1979   | ME-HZ   | ME-HZ   |
|             | 240          | -1979   | ME-HZP  | ME-HZP  |
|             | 280          | -1979   |   |   |
|             | 300          | 1979-   |   |   |
|             | 230          | 1979-   | ME-HF   | ME-HF   |
|             | 240          | 1979-   | ME-HFP  | ME-HFP  |
|             | 280          | 1979-   | ME-HM   | ME-HM   |
|             |              | ME-HMP  | ME-HMP  |   |









# AUTOMÓVIL - CAMIONETA

## CAR - PICK-UP TRUCKS

| MARCA BRAND | MODELO MODEL |  |  |  |
|-------------|--------------|---|---|---|
| STEYR-PUCH  | PANDA 4x4    | 1983-1985   | AF-7I   | IMS-3   |
|             |              |   | AF-7IP  | IMS-3P  |
|             |              |   | FI-9I   | IMS-5   |
|             |              |   | FI-9IP  | IMS-5P  |
|             | PANDA 4x4    | 1986-1988   | FI-1  | IMS-3   |
|             |              |   | FI-11   | IMS-3P  |
|             |              |   | FI-11P  | IMS-5   |
|             |              |   | FI-1P   | IMS-5P  |
|             | PANDA 4x4    | 1989-   | FI-1  | FI-1  |
|             |              |   | FI-11   | FI-11   |
|             |              |   | FI-11P  | FI-11P  |
|             |              |   | FI-1P   | FI-1P   |
| SUBARU      | ALCYONE      | 1986-   | DAT-6   | DAT-6   |
|             | E10 VAN      | 1986-   | DAT-6D  | DAT-6D  |
|             | E12 VAN      | 1986-   | DAT-6DP   | DAT-6DP   |
|             | E5 VAN       | 1986-   | DAT-6DP1  | DAT-6DP1  |
|             | E7 VAN       | 1986-   | DAT-6P  | DAT-6P  |
|             | HUNTER       | 1986-   | DAT-6P1   | DAT-6P1   |
|             | JUSTY (EU)   | 1986-1996   |   |   |
|             | L 1.3        | 1986-   |   |   |
|             | L 1.6        | 1986-   |   |   |
|             | L 1.8        | 1986-   |   |   |
|             | LEGACY 4WD   | 1986-1996   |   |   |
|             | LEONE        | 1986-   |   |   |
|             | M 70         | 1986-   |   |   |
|             | M 80         | 1986-   |   |   |
|             | SAMBAR VAN   | 1986-   |   |   |
|             | XT           | 1986-   |   |   |
|             | E10 DOMINGO  | 1984-1985   | DAT-11D   | DAT-8I  |
|             | JUSTY        | 1984-1985   | DAT-11DP  | DAT-8IP   |
|             | L 1.3        | 1984-1985   | WAS-2P  | DAT-8IP1  |
|             | L 1.6        | 1984-1985   |   |   |
|             | L 1.8        | 1984-1985   |   |   |
|             | M 70         | 1984-1985   |   |   |
|             | M 80         | 1984-1985   |   |   |
|             | REX          | 1984-1985   |   |   |
|             | HATCBACK     | 1985-   | DAT-6   | DAT-6   |
|             | JUSTY XT     | 1985-1996   | DAT-6P  | DAT-6P  |
|             | LEGACY       | 1985-1996   | DAT-6P1   | DAT-6P1   |
|             | LOYALE       | 1985-   | DAT-7   | DAT-7   |
|             |              |   | DAT-7P  | DAT-7P  |
|             | IMPREZA      | 1995  | DAT-6   | DAT-6   |
|             |              |   | DAT-6P1   | DAT-6P1   |
|             | JUSTY        | 1991-1996   | DAT-6   | DAT-7   |
|             |              |   | DAT-6P1   |   |
|             | LEONE        | 1973-1982   | DAT-11D   | DAT-1D  |
|             | REX          | 1973-1982   | DAT-11DP  | DAT-1DP   |
|             | SEDAN        | 1973-1982   | WAS-2P  | DAT-1I  |
|             | TIGRE        | 1973-1982   |   | DAT-1IP   |
|             |              |   |   | DAT-2D  |
|             |              |   |   | DAT-2DP   |
|             |              |   |   | DAT-2I  |
|             |              |   |   | DAT-2IP   |



| MARCA BRAND | MODELO MODEL |  |  |  |       |
|-------------|--------------|---|---|---|-------|
| SUBARU      | LEONE        | 1983-1984   | DAT-11D   | DAT-2I  |       |
|             | REX          | 1983-1984   | DAT-11DP  | DAT-2IP   |       |
|             | SEDAN        | 1983-1984   | WAS-2P  |   |       |
|             | TIGRE        | 1983-1984   |   |   |       |
|             | MODELOS      | 1970-1972   | DAT-1I  | DAT-1I  |       |
|             |              |   | DAT-1IP   | DAT-1IP   |       |
|             | MODELOS      | 2000-   | DAT-15  | DAT-15  |       |
|             | SULKY        | 50  | -1991   | BH-4  | ZA-1  |
|             |              | 125   | -1991   |   | ZA-1P |
|             | SUNBEAM      | 1.0   | -   | LF-SL   | LF-SL |
| 1.3         |              | -   | LF-SLP  | LF-SLP  |       |
| 1.6         |              | -   |   |   |       |
| SUZUKI      | ALTO         | 1976-1984   | TOYO-14   | TOYO-14   |       |
|             | CERVO        | 1976-1984   | TOYO-14P  | TOYO-14P  |       |
|             | CULTUS       | 1976-1984   |   |   |       |
|             | ESTEEM       | 1976-1984   |   |   |       |
|             | FRONTE       | 1976-1984   |   |   |       |
|             | GOLD FINGER  | 1976-1984   |   |   |       |
|             | JIMMY        | 1976-1984   |   |   |       |
|             | S.CARRY      | 1988  |   |   |       |
|             | SAMURAI      | 1976-1984   |   |   |       |
|             | SJ 30        | 1976-1984   |   |   |       |
|             | SJ 310       | 1976-1984   |   |   |       |
|             | SJ 410       | 1976-1984   |   |   |       |
|             | SJ 413       | 1976-1984   |   |   |       |
|             | VITARA       | 1988  |   |   |       |
|             | ALTO         | 1986-1995   | SUZU-7  | SUZU-7  |       |
|             | CERVO        | 1986-   | SUZU-7P   | SUZU-7P   |       |
|             | CULTUS       | 1986-   |   |   |       |
|             | ALTO         | 1996  | SUZU-8  | SUZU-8  |       |
|             | CARRY VAN    | 1989-1991   | SUZU-8P   | SUZU-8P   |       |
|             | EVERY VAN    | 1989-1991   |   |   |       |
|             | SWIFT        | 1989-1991   |   |   |       |
|             | VITARA       | 1989-1991   |   |   |       |
|             | VITARA       | 1991  |   |   |       |
|             | X-90         | 1995-1997   |   |   |       |
|             | BALENO       | 1995  | SUZU-10   | SUZU-10   |       |
|             | ESCUDO       | 1989-1991   | SUZU-10P  | SUZU-10P  |       |
| SIDEKICK    | 1989-1991    |   |   |   |       |
| SWIFT       | 1991-1996    |   |   |   |       |
| CULTUS      | 1984-1991    | MIT-2I  | MIT-2I  |   |       |
| SAMURAI     | 1984-1989    | TOYO-14   | TOYO-14   |   |       |
|             |              | TOYO-14P  | TOYO-14P  |   |       |
| LJ 50       | 1970-        | TOYO-14   | TOYO-14   |   |       |
| LJ 80       | 1970-        | TOYO-14P  | TOYO-14P  |   |       |
|             |              | TOYO-K1   | TOYO-K1   |   |       |
|             |              | TOYO-K1P  | TOYO-K1P  |   |       |
| SAMURAI     | 1989-        | IMS-11P   | IMS-11P   |   |       |
|             |              | SUZU-9P   | SUZU-9P   |   |       |
| SJ 410      | 1985-1988    | IMS-7   | IMS-10  |   |       |
| SJ 413      | 1985-1988    | IMS-7P  |   |   |       |
| SJ 410      | 1989-1991    | IMS-7   | IMS-11P   |   |       |



| MARCA BRAND  | MODELO MODEL |  |  |  |
|--------------|--------------|---|---|---|
| SUZUKI       | SJ 413       | 1989-1991   | IMS-7P  | SUZU-9P   |
| TALBOT SIMCA | 150          | 1975-   | LMP-3   | LMP-3   |
|              | 1510         | 1975-   | LMP-3P  | LMP-3P  |
|              | ALPINE       | 1975-   |   |   |
|              | HORIZON      | 1980-1983   |   |   |
|              | MINX         | 1980-1983   |   |   |
|              | OMNI         | 1980-1983   |   |   |
|              | RAPIER       | 1975-   |   |   |
|              | 160 GT       | 1979-   | CHR-3   | CHR-3   |
|              | 180          | 1979-   | NE-22P2   | NE-22P2   |
|              | 1307         | 1975-   |   |   |
|              | 1308         | 1975-   |   |   |
|              | 1309         | 1978-   |   |   |
|              | HORIZON      | 1984-   |   |   |
|              | MINX         | 1984-   |   |   |
|              | MURENA       | 1980-   |   |   |
|              | OMNI         | 1984-   |   |   |
|              | 1000         | 1968-1973   | NE-3  | RO-3  |
|              | 1005         | 1968-1973   | NE-3P1  |   |
|              | 1006         | 1968-1973   | NE-3P2  |   |
|              | 1007         | 1968-1973   |   |   |
|              | 1100         | 1968-1973   |   |   |
|              | 1301         | 1970-1973   |   |   |
|              | 1501         | 1970-   |   |   |
|              | 1100         | 1974-   | CHR-3<br>NE-22P2  | RO-3  |
|              | BAGHEERA     | 1973-   | NE-3<br>NE-3P1<br>NE-3P2  |   |
|              | HORIZON      | 1977-1979   | CHR-3   | CHR-3   |
|              | HORIZON GL   | 1977-1979   | NE-22P2   | LMP-3   |
|              | MINX         | 1977-1979   |   | LMP-3P  |
|              | OMNI         | 1977-1979   |   | NE-22P2   |
|              | RANCH        | 1977-   | CHR-3<br>NE-22P2  |   |
|              | RAPIER       | 1980-   | CHR-3   | CHR-3   |
|              | SAMBA        | 1981-1983   | NE-22P2   | NE-22P2   |
|              | SOLARA       | 1980-   | NE-33P1   | NE-33P1   |
|              | TAGORA       | 1980-   |   |   |
|              | SAMBA        | 1984-   | CHR-3<br>NE-22P2<br>NE-33P1   | CHR-3<br>NE-22P2<br>VA-6<br>VA-6P   |
| TATA         | INDICA       | 2000-   | TAT-1D<br>TAT-1DP   | TAT-1D<br>TAT-1DP   |
| TOYOTA       | 3 DR LIFT B. | 1988-1989   | TOYO-12   | TOYO-12   |
|              | 4 RUNNER     | 1988-1989   | TOYO-12P1   | TOYO-12P1   |
|              | CELICA       | 1988-1989   | TOYO-8  | TOYO-8  |
|              | COROLLA      | 1988-1989   | TOYO-8P   | TOYO-8P   |
|              | MR2          | 1989-1990   |   |   |
|              | SUPRA EFI SR | 1988-1989   |   |   |
|              | TERCEL       | 1989-   |   |   |
|              | 4 RUNNER     | 1970-1986   | TOYO-12   | TOYO-12   |



| MARCA BRAND | MODELO MODEL |  |  |  |
|-------------|--------------|---|---|---|
| TOYOTA      | L. CRUISER   | 1970-1986   | TOYO-12P1   | TOYO-12P1   |
|             |              |   | TOYO-2  | TOYO-2  |
|             |              |   | TOYO-K1   | TOYO-K1   |
|             |              |   | TOYO-K1P  | TOYO-K1P  |
|             | 4 RUNNER     | 1986-1988   | TOYO-16   | TOYO-16   |
|             | CAMRY        | 1990-1991   | TOYO-16P  | TOYO-16P  |
|             | DYNA         | 1990-   | TOYO-16P1   | TOYO-16P1   |
|             | L. CRUISER   | 1986-1989   | TOYO-5  | TOYO-5  |
|             | LITEACE      | 1990-   | TOYO-5P   | TOYO-5P   |
|             | RUNNER       | 1986-1989   | TOYO-5P1  | TOYO-5P1  |
|             | STARLET      | 1990-1997   |   |   |
|             | VX TURBO     | 1986-1989   |   |   |
|             | 4 RUNNER     | 1990-1991   | TOYO-20D  | TOYO-20D  |
|             | CARINA       | 1990-1994   | TOYO-9  | TOYO-9  |
|             | CELICA COUPE | 1991-1996   | TOYO-9P   | TOYO-9P   |
|             | COROLLA      | 1990-1991   | TOYO-9P1  | TOYO-9P1  |
|             | CRESSIDA     | 1990-   |   |   |
|             | HIACE VAN    | 1990-   |   |   |
|             | HILUX 4x4    | 1995  |   |   |
|             | HILUX VAN    | 1990-   |   |   |
|             | L. CRUISER   | 1990-1991   |   |   |
|             | MR2          | 1991-1997   |   |   |
|             | RUNNER       | 1990-1991   |   |   |
|             | 4 RUNNER     | 1991-   | TOYO-15   | TOYO-15   |
|             | CAMRY        | 1991-   | TOYO-15P  | TOYO-15P  |
|             | CARINA S.W.  | 1995  |   |   |
|             | CELICA       | 1995  |   |   |
|             | COROLLA      | 1991-1996   |   |   |
|             | RAV4         | 1995  |   |   |
|             | RUNNER       | 1991-   |   |   |
|             | ARROW        | 1970-1972   | TOYO-4  | TOYO-4  |
|             | CELICA SUPRA | 1982-1985   | TOYO-4P   | TOYO-4P   |
|             | CROWN        | 1970-1972   |   |   |
|             | CAMRY        | 1984-1989   | TOYO-13<br>TOYO-13P1<br>TOYO-28P  | TOYO-13<br>TOYO-13P1<br>TOYO-28P  |
|             | CAMRY GL     | 1984-   | TOYO-3  | TOYO-3  |
|             | CAMRY GLI    | 1984-   | TOYO-3P   | TOYO-3P   |
|             | CARINA       | 1983-1985   | TOYO-8  | TOYO-8  |
|             | COROLLA      | 1975-1982   | TOYO-8P   | TOYO-8P   |
|             | COROLLA 4DR  | 1986-1996   |   |   |
|             | CORONA       | 1983-1985   |   |   |
|             | CORSA        | 1983-1985   |   |   |
|             | CRESSIDA     | 1983-1985   |   |   |
|             | CRESTA       | 1983-1985   |   |   |
|             | CROWN        | 1983-1985   |   |   |
|             | MARK II      | 1983-1985   |   |   |
|             | MR2          | 1983-1985   |   |   |
|             | SPRINTER     | 1983-1985   |   |   |
|             | TERCEL       | 1983-1985   |   |   |
|             | CARINA       | 1972-1982   | TOYO-14   | TOYO-14   |
|             | CELICA       | 1972-1982   | TOYO-14P  | TOYO-14P  |
|             | COROLLA      | 1972-1974   | TOYO-K1   | TOYO-K1   |



# AUTOMÓVIL - CAMIONETA

## CAR - PICK-UP TRUCKS

| MARCA BRAND | MODELO MODEL |  |  |  |
|-------------|--------------|---|---|---|
| TOYOTA      | CORONA       | 1972-1974   | TOYO-K1P  | TOYO-K1P  |
|             | CROWN        | 1972-1982   |   |   |
|             | HIACE        | 1975-1982   |   |   |
|             | HILUX        | 1973-1978   |   |   |
|             | MARK II      | 1972-1982   |   |   |
|             | PUBLICA      | 1972-1974   |   |   |
|             | STARLET      | 1972-1982   |   |   |
|             | CARINA       | 1985-1986   | TOYO-3  | TOYO-3  |
|             | CORONA       | 1985-1986   | TOYO-3P   | TOYO-3P   |
|             | SPRINTER     | 1985-1986   |   |   |
|             | TERCEL 4WD   | 1985-1986   |   |   |
|             | CARINA       | 1994  | TOYO-19P  | TOYO-19P  |
|             | CELICA       | 1983-1985   | TOYO-12   | TOYO-12   |
|             |              |   | TOYO-12D  | TOYO-12D  |
|             |              |   | TOYO-12P1   | TOYO-12P1   |
|             |              |   | TOYO-22   | TOYO-22   |
|             |              |   | TOYO-22D  | TOYO-22D  |
|             |              |   | TOYO-3  | TOYO-3  |
|             |              |   | TOYO-3P   | TOYO-3P   |
|             |              |   | TOYO-8  | TOYO-8  |
|             |              |   | TOYO-8P   | TOYO-8P   |
|             |              |   | TOYO-K1   | TOYO-K1   |
|             |              |   | TOYO-K1P  | TOYO-K1P  |
|             | CELICA       | 1986-1988   | TOYO-10   | TOYO-10   |
|             | COROLLA ST   | 1988-1989   | TOYO-10P  | TOYO-10P  |
|             | TERCEL       | 1987-1988   | TOYO-11   | TOYO-11   |
|             |              |   | TOYO-11P  | TOYO-11P  |
|             | CELICA       | 1990-1995   | TOYO-10   | TOYO-10   |
|             |              |   | TOYO-10P  | TOYO-10P  |
|             |              |   | TOYO-10P1   | TOYO-10P1   |
|             |              |   | TOYO-11   | TOYO-11   |
|             |              |   | TOYO-11P  | TOYO-11P  |
|             |              |   | TOYO-11P1   | TOYO-11P1   |
|             |              |   | TOYO-20D  | TOYO-20D  |
|             |              |   | TOYO-9  | TOYO-9  |
|             |              |   | TOYO-9P   | TOYO-9P   |
|             |              |   | TOYO-9P1  | TOYO-9P1  |
|             | CELICA 4WD   | 1990-1991   | TOYO-10   | TOYO-10   |
|             | MR2          | 1990-1991   | TOYO-10P  | TOYO-10P  |
|             | PREVIA       | 1993-1997   | TOYO-10P1   | TOYO-10P1   |
|             |              |   | TOYO-11   | TOYO-11   |
|             |              |   | TOYO-11P  | TOYO-11P  |
|             |              |   | TOYO-11P1   | TOYO-11P1   |
|             | CELICA COUPE | 1991-1994   | TOYO-37D  | TOYO-37D  |
|             | CELICA LIFT. | 1991-1996   | TOYO-10   | TOYO-10   |
|             |              | TOYO-10P1   | TOYO-10P1   |   |
| COROLLA     | 1983-1987    | TOYO-12   | TOYO-12   |   |
| TERCEL      | 1985-1987    | TOYO-12P1   | TOYO-12P1   |   |
|             |              | TOYO-22   | TOYO-22   |   |
|             |              | TOYO-22D  | TOYO-22D  |   |
|             |              | TOYO-K1   | TOYO-K1   |   |
|             |              | TOYO-K1P  | TOYO-K1P  |   |
| COROLLA 5   | 1972-1976    | TOYO-2  | TOYO-2  |   |



| MARCA BRAND  | MODELO MODEL |  |  |  |
|--------------|--------------|---|---|---|
| TOYOTA       |              |   | TOYO-4  | TOYO-4  |
|              |              |   | TOYO-4P   | TOYO-4P   |
|              | COROLLA DX   | 1985-1996   | TOYO-23   | TOYO-23   |
|              | GRESSIDA     | 1977-1978   | TOYO-23P  | TOYO-23P  |
|              | CRESTA       | 1977-1978   |   |   |
|              | COROLLA GT   | 1985-1996   | TOYO-8  | TOYO-8  |
|              |              |   | TOYO-8P   | TOYO-8P   |
|              | COROLLA SM   | 1973-1978   | TOYO-14   | TOYO-14   |
|              |              |   | TOYO-14P  | TOYO-14P  |
|              |              |   | TOYO-4  | TOYO-4  |
|              |              |   | TOYO-4P   | TOYO-4P   |
|              |              |   | TOYO-K1   | TOYO-K1   |
|              |              |   | TOYO-K1P  | TOYO-K1P  |
|              | COROLLA SW   | 1993-1996   | TOYO-17   | TOYO-17   |
|              |              |   | TOYO-17P  | TOYO-17P  |
|              | GRESSIDA     | 1984-1987   | TOYO-28P  | TOYO-28P  |
|              | GRESSIDA     | 1985-1987   | TOYO-13   | TOYO-13   |
|              |              |   | TOYO-13P1   | TOYO-13P1   |
|              | FX 16        | 1987-1988   | TOYO-K1   | TOYO-K1   |
|              | STARLET      | 1984-1990   | TOYO-K1P  | TOYO-K1P  |
|              | HDJ 80       | 1991-   | TOYO-18P  | TOYO-18P  |
|              | L. CRUISER   | 1991-   |   |   |
|              | PASEO        | 1991-1997   | TOYO-10   | TOYO-10   |
|              |              |   | TOYO-10P  | TOYO-10P  |
|              |              |   | TOYO-10P1   | TOYO-10P1   |
| VARIOS       | -1969        | TOYO-25   | TOYO-25   |   |
| VARIOS       | 1970-        | TOYO-29   | TOYO-29   |   |
| TRABANT      | TODOS        | -   | DOB-1   | DOB-1   |
|              |              |   | DOB-1D  | DOB-1D  |
|              |              |   | DOB-2   | DOB-2   |
|              |              |   | DOB-2D  | DOB-2D  |
|              |              |   | DOB-3   | DOB-3   |
|              |              |   | DOB-3D  | DOB-3D  |
| TRIUMPH      | ACCLAIM      | 1981-   | HOND-1  | HOND-1  |
|              |              |   | HOND-1P   | HOND-1P   |
|              |              |   | HOND-2  | HOND-2  |
|              |              |   | HOND-2P   | HOND-2P   |
| DOLOMITE     | 1973-        | UN-NH   | UN-FS   |   |
| TOLEDO       | 1973-        | UN-NHP  |   |   |
| GT6 MK3      | -            | FO-FR   | UN-NH   |   |
|              |              | FO-FRP  | UN-NHP  |   |
|              |              | UN-NH   |   |   |
|              |              | UN-NHP  |   |   |
|              |              | WAS-2P  |   |   |
| GTX MK3      | 1972         | FO-FR   | UN-NH   |   |
| SPITFIRE     | 1972-1974    | FO-FRP  | UN-NHP  |   |
| SPITFIRE MK4 | 1972         | WAS-2P  |   |   |
| MODELOS      | -1969        | UN-FS   | UN-44   |   |
|              |              |   | UN-FP   |   |
| SPITFIRE     | 1974-1978    | LF-WB   | UN-NH   |   |
|              |              | LF-WBP  | UN-NHP  |   |
| SPITFIRE     | 1979-        | UN-NH   |   |   |
|              |              | UN-NHP  |   |   |



| MARCA BRAND     | MODELO MODEL |  |  |  |
|-----------------|--------------|---|---|---|
| TRIUMPH         | TR6 PJ SPID. | 1969-1977   | FO-FR<br>FO-FRP<br>WAS-2P   | UN-FT<br>UN-NH<br>UN-NHP  |
|                 | TR7 COUPE    | 1975-1981   | UN-NH   | UN-FT   |
|                 | TR7 SPIDER   | 1975-1981   | UN-NHP  | UN-NH<br>UN-NHP   |
| UAZ             | 452          | -   | BH-1  | IMS-3   |
|                 | 469          | -   | BH-1P   | IMS-3P  |
|                 | 469 DIESEL   | -   | VOL-2   | IMS-5   |
|                 |              |   | VOL-3   | IMS-5P<br>VOL-2<br>VOL-3  |
|                 | FURGON 4R.M  | -   | VOL-2   | IMS-3   |
|                 |              |   |   | IMS-3P  |
| IMS-5<br>IMS-5P |              |   |   |   |
| ROAD MASTER     | -            | BS-6  |   |   |
| VAUXHALL        | ASTRA        | 1975-1979   | OP-J  | OP-J  |
|                 | CHEVRETTE    | 1975-1979   | OP-JP   | OP-JP   |
|                 | ASTRA        | 1984-1995   | OP-D  | OP-D  |
|                 | ASTRAMAX     | 1984-   | OP-DP   | OP-DP   |
|                 | BELMONT      | 1984-   | OP-S  | OP-S  |
|                 | NOVA         | 1984-   | OP-SP   | OP-SP   |
|                 | ROYALE       | 1984-   |   |   |
|                 | CARLTON      | 1978-1981   | OP-R  | OP-R  |
|                 | VICEROY      | 1978-1989   | OP-RP   | OP-RP   |
|                 |              |   | OP-T  | OP-T  |
|                 |              |   | OP-TP   | OP-TP   |
|                 | CARLTON      | 1982-   | OP-WHP  | OP-WHP  |
|                 | CAVALIER     | 1982-   | OP-WYP  | OP-WYP  |
|                 | SENATOR      | 1982-   |   |   |
|                 | CAVALIER     | 1975-1981   | OP-AB   | OP-AB   |
|                 |              |   | OP-ABP  | OP-ABP  |
|                 |              |   | OP-BA   | OP-BA   |
|                 |              |   | OP-BAP  | OP-BAP  |
|                 |              |   | OP-J  | OP-J  |
| OP-JP           |              |   | OP-JP   |   |
| FIRENZA         | -            | LF-RO<br>LF-ROP   | LF-6  |   |
| VOLGA           | GAZ 024      | -   | VOL-1   | VOL-1   |
|                 |              |   | VOL-1P  | VOL-1P  |
|                 | GAZ 029      | -   | NE-3  | VOL-1   |
|                 |              |   | NE-3P   | VOL-1P  |
|                 |              |   | NE-3P2  | VOL-2<br>VOL-2D<br>VOL-3  |
|                 |              |   |   | VOL-3   |
|                 |              |   |   | VOL-5P  |
|                 | GAZ 3110     | -   | NE-3  | VOL-1   |
|                 |              |   | NE-3P   | VOL-1P  |
|                 |              |   | NE-3P2  | VOL-4   |
| VOLKSWAGEN      | 411          | 1970-1972   | VO-K  |   |
|                 | 412          | 1970-1972   |   |   |
|                 | 1500         | 1970-1972   |   |   |



| MARCA BRAND  | MODELO MODEL |  |  |  |
|--------------|--------------|---|---|---|
| VOLKSWAGEN   | 1600         | 1970-1972   |   |   |
|              | BRASILIA     | 1970-1972   |   |   |
|              | 411          | 1973-1974   | VO-VB   | VO-VB   |
|              | 412          | 1973-1974   | VO-VBP  | VO-VBP  |
|              | BRASILIA     | 1973-1974   |   |   |
|              | CABRIOLET    | 1975-1981   |   |   |
|              | DERBY AMAZON | 1977-1980   |   |   |
|              | FAMILCAR     | 1977-1980   |   |   |
|              | GOLF         | 1977-1980   |   |   |
|              | IGALA        | 1973-1974   |   |   |
|              | PASSAT       | 1973  |   |   |
|              | PASSAT       | 1977-1980   |   |   |
|              | POLO         | 1975-1976   |   |   |
|              | POLO         | 1977-1980   |   |   |
|              | SCIROCCO     | 1975-1981   |   |   |
|              | 1303 CABRIO  | 1970-   | HU-SU   | VO-M<br>VO-MP   |
|              |              |   |   |   |
|              | ALL STAR     | 1991-   | VO-2  | VO-2  |
|              | CALIFORNIA   | 1991-   | VO-2P   | VO-2P   |
|              | CLUB VAN     | 1991-   |   |   |
|              | POLO         | 1991-1995   |   |   |
|              | SINCRO       | 1991-   |   |   |
|              | TRANSPORTER  | 1991-1995   |   |   |
|              | BEETLE       | 1970-1978   | VO-M  | VO-M  |
|              | EL VOLKSWAGE | 1970-1978   | VO-MP   | VO-MP   |
|              | ESCARABAJO   | 1970-1978   |   |   |
|              | FUSCA        | 1970-1978   |   |   |
|              | CADDY        | -   | AU-1  | AU-1  |
|              | POLO         | 1981-1982   | AU-HV   | AU-HV   |
|              |              |   | AU-HVP  | AU-HVP  |
|              |              |   | VO-HV<br>VO-HVP   | VO-HV<br>VO-HVP   |
|              | CORRADO      | 1988-   | AU-AN   | AU-AN   |
|              | GOLF         | 1988-1990   | AU-ANP  | AU-ANP  |
| GOLF         | 1991-1995    | HU-AN   | HU-AN   |   |
| JETTA ATLAN. | 1988-        | VO-2  | VO-2  |   |
| PASSAT       | 1988-1995    | VO-2P   | VO-2P   |   |
| VENTO        | 1992-1995    |   |   |   |
| DERBY AMAZON | 1981-1982    | AU-1  | AU-1  |   |
| DERBY AMAZON | 1985-1987    | AU-HV   | AU-HV   |   |
| GOLF         | 1981-1982    | AU-HVP  | AU-HVP  |   |
| GOLF         | 1985-1987    | VO-HV   | VO-HV   |   |
| GOLF CABRIO  | 1981-1984    | VO-HVP  | VO-HVP  |   |
| JETTA ATLAN. | 1981-1984    | VO-VB   | VO-VB   |   |
| JETTA ATLAN. | 1985-1987    | VO-VBP  | VO-VBP  |   |
| PASSAT       | 1981-1984    |   |   |   |
| PASSAT       | 1985-1987    |   |   |   |
| POLO         | 1985-1991    |   |   |   |
| SANTANA      | 1981-1982    |   |   |   |
| SCIROCCO     | 1981-1982    |   |   |   |
| SCIROCCO     | 1985-1987    |   |   |   |
| GOLF         | 1975-1977    | VO-VB   | HU-SU<br>VO-VB  |   |
|              |              | VO-VBP  | VO-VB   |   |



# AUTOMÓVIL - CAMIONETA

## CAR - PICK-UP TRUCKS

| MARCA BRAND         | MODELO MODEL        |  |  |  |                 |
|---------------------|---------------------|---|---|---|-----------------|
| VOLKSWAGEN          |                     |   |   | VO-VBP  |                 |
|                     | GOLF                | 1987-1988   | VO-2<br>VO-2P<br>VO-AHP   | VO-2<br>VO-2P<br>VO-AHP   |                 |
|                     | K 70                | 1970-1973   | FO-PN   | FO-PN   |                 |
|                     | K 70 LS             | 1970-1973   | VO-VB<br>VO-VBP   | VO-VB<br>VO-VBP   |                 |
|                     | LT 28D              | 1970-1979   | VO-R  | VO-R  |                 |
|                     | LT 31               | 1970-1979   | VO-RP   | VO-RP   |                 |
|                     | PASSAT FAM.         | 1973-1976   |   |   |                 |
|                     | TL 31               | 1970-1979   |   |   |                 |
|                     | TL 45               | 1970-1979   |   |   |                 |
|                     | TL 50               | 1970-1979   |   |   |                 |
|                     | MODELOS             | 1966-1969   | FO-D<br>VO-L  | VO-L  |                 |
|                     | TARO NISSAN         | 1989-   | TOYO-20D<br>TOYO-9<br>TOYO-9P<br>TOYO-9P1   | TOYO-20D<br>TOYO-9<br>TOYO-9P<br>TOYO-9P1   |                 |
|                     | TL 31               | 1980-   | VO-N  | VO-N  |                 |
|                     | TL 35               | 1980-   | VO-NP   | VO-NP   |                 |
|                     | TL 45               | 1980-   |   |   |                 |
|                     | TL 50               | 1980-   |   |   |                 |
|                     | TRANSPORTER         | 1980-1991   |   |   |                 |
|                     | VAGON               | 1980-   |   |   |                 |
|                     | VOLKSWAGEN (ARGEN.) | 1500  | -   |   | CHR-8<br>CHR-8P |
|                     |                     | 1500  | 1980-   |   |                 |
| 1800                |                     | 1980-   |   |   |                 |
| GACEL               |                     | -   | VO-FHP1   | VO-FHP1   |                 |
| GOL                 |                     | -1995   | VO-FHP1<br>VO-VB<br>VO-VBP  | VO-FHP1<br>VO-VB<br>VO-VBP  |                 |
| GOL                 |                     | 1996  | VO-2DP  | VO-2DP  |                 |
| GOL                 |                     | 1997-   | VO-8P   | VO-8P   |                 |
| KOMBI               |                     | -   | VO-R<br>VO-RP   | VO-R<br>VO-RP   |                 |
| POINTER             |                     | -   | VO-5P   | VO-5P   |                 |
| SAVEIRO             |                     | -   | VO-HV<br>VO-HVP<br>VO-VB<br>VO-VBP  | VO-HV<br>VO-HVP<br>VO-VB<br>VO-VBP  |                 |
| SENDA               |                     | -   | VO-HV<br>VO-HVP   | VO-HV<br>VO-HVP   |                 |
| VOLKSWAGEN (BRASIL) |                     | FOX   | 1975-1976   | VO-VB   | VO-VB           |
|                     |                     | FOX   | 1977-1980   | VO-VBP  | VO-VBP          |
|                     |                     | GOL   | 1975-1976   |   |                 |
|                     |                     | GOL   | 1977-1980   |   |                 |
|                     | PARATI              | 1973  |   |   |                 |
|                     | PARATI              | 1977-1980   |   |   |                 |
|                     | QUANTUM             | 1973  |   |   |                 |
|                     | QUANTUM             | 1977-1980   |   |   |                 |
|                     | FOX                 | 1981-1982   | AU-1  | AU-1  |                 |

| MARCA BRAND         | MODELO MODEL       |  |  |  |   |               |
|---------------------|--------------------|---|---|---|---|---------------|
| VOLKSWAGEN (BRASIL) | GOL                | 1981-1982   | AU-HV<br>AU-HVP<br>VO-HV<br>VO-HVP  | AU-HV<br>AU-HVP<br>VO-HV<br>VO-HVP  |   |               |
|                     | FOX                | 1985-1991   | AU-1  | AU-1  |   |               |
|                     | GOL                | 1985-1991   | AU-HV   | AU-HV   |   |               |
|                     | PARATI             | 1981-1984   | AU-HVP  | AU-HVP  |   |               |
|                     | PARATI             | 1985-1987   | VO-HV   | VO-HV   |   |               |
|                     | QUANTUM            | 1981-1984   | VO-HVP  | VO-HVP  |   |               |
|                     | QUANTUM            | 1985-1987   | VO-VB   | VO-VB   |   |               |
|                     | SANTANA            | 1981-1982   | VO-VBP  | VO-VBP  |   |               |
|                     | FOX                | 1991-   | VO-2  | VO-2  |   |               |
|                     | GOL                | 1991-   | VO-2P   | VO-2P   |   |               |
|                     | PARATI             | 1988-   | AU-AN   | AU-AN   |   |               |
|                     | QUANTUM            | 1988-   | AU-ANP<br>HU-AN<br>VO-2<br>VO-2P  | AU-ANP<br>HU-AN<br>VO-2<br>VO-2P  |   |               |
|                     | VARIOS             | 1996-   | VO-2DP1<br>VO-2P1<br>VO-8P1   | VO-2DP1<br>VO-2P1<br>VO-8P1   |   |               |
|                     | VOLKSWAGEN (CHINA) | SHANGHAI  | 1973  | VO-VB   | VO-VB   |               |
|                     |                    | SHANGHAI  | 1977-1980   | VO-VBP  | VO-VBP  |               |
|                     |                    | SHANGHAI  | 1981-1984   | AU-1  | AU-1  |               |
|                     |                    | SHANGHAI  | 1985-1987   | AU-HV<br>AU-HVP<br>VO-HV<br>VO-HVP<br>VO-VB<br>VO-VBP                               | AU-HV<br>AU-HVP<br>VO-HV<br>VO-HVP<br>VO-VB<br>VO-VBP |               |
|                     |                    | SHANGHAI  | 1988-   | AU-AN<br>AU-ANP<br>HU-AN<br>VO-2<br>VO-2P   | AU-AN<br>AU-ANP<br>HU-AN<br>VO-2<br>VO-2P             |               |
|                     |                    | VOLKSWAGEN (MEXICO)   | ESCARABAJO  | -   | VO-M<br>VO-MP   | VO-M<br>VO-MP |
|                     |                    |   | VOLVO   | 66 DL   | 1972-1976   |               |
| 66 GL               |                    | 1972-1976   |   |   |   |               |
| 66 L                |                    | 1972-1976   |   |   |   |               |
| 66 MARATHON         |                    | 1972-1976   |   |   |   |               |
| 66 SL               | 1972-1976          |   |   |   |   |               |
| 142                 | 1968-1972          | NE-13   |   | UN-FR   |   |               |
| 144                 | 1968-1972          |   |   |   |   |               |
| 145                 | 1968-1972          |   |   |   |   |               |
| 164                 | 1968-1972          |   |   |   |   |               |
| 142                 | 1973-1976          | NE-10   |   | NE-9  |   |               |
| 144                 | 1973-1976          | NE-10P  |   | NE-9P   |   |               |
| 145                 | 1973-1976          |   |   | WAS-1   |   |               |
| 164                 | 1973-1976          |   |   |   |   |               |
| 240                 | 1973-1976          |   |   |   |   |               |

| MARCA BRAND | MODELO MODEL |  |  |  |
|-------------|--------------|---|---|---|
| VOLVO       | 242          | 1973-1976   |   |   |
|             | 244          | 1973-1976   |   |   |
|             | 264          | 1973-1976   |   |   |
|             | 240          | 1977-1978   | NE-12   | NE-9  |
|             | 242          | 1977-1978   | NE-12P  | NE-9P   |
|             | 244          | 1977-1978   |   |   |
|             | 245          | 1977-1978   |   |   |
|             | 246          | 1977-1978   |   |   |
|             | 262          | 1977-1978   |   |   |
|             | 264          | 1977-1978   |   |   |
|             | 265          | 1977-1978   |   |   |
|             | 240          | 1978-1984   | NE-12   | NE-12   |
|             | 242          | 1978-1983   | NE-12P  | NE-12P  |
|             | 244          | 1978-1983   |   |   |
|             | 245          | 1978-1983   |   |   |
|             | 262          | 1978-1983   |   |   |
|             | 264          | 1978-1983   |   |   |
|             | 265          | 1978-1983   |   |   |
|             | 240          | 1984-1985   | NE-12   | NE-12   |
|             | 740          | 1986-1991   | NE-12P  | NE-12P  |
|             | 760          | 1984-1987   | NE-18   | NE-18   |
|             | 780          | 1986-1991   | NE-18P  | NE-18P  |
|             | 940          | 1991-1996   |   |   |
|             | 340          | 1976-1984   | HU-DF   | AKS-1   |
|             | 343          | 1976-1984   | HU-DFP  |   |
|             | 345          | 1976-1984   | HU-DFP1   |   |
|             | 360          | 1976-1984   |   |   |
|             | 340          | 1985-1986   | HU-DF   | HU-DF   |
|             | 360          | 1985-1986   | HU-DFP  | HU-DFP  |
|             |              |   | HU-DFP1   | HU-DFP1   |
|             | 440          | 1987-   | HU-DHP  | HU-DHP  |
|             | 460          | 1987-   | HU-DNP  | HU-DNP  |
|             | 480          | 1987-   |   |   |
| 760         | 1991-        | NE-40   | NE-40   |   |
| 762         | 1991-        | NE-40P  | NE-40P  |   |
| 764         | 1991-        | NE-41P  | NE-41P  |   |
| 765         | 1991-        |   |   |   |
| 960         | 1991-1996    |   |   |   |
| 850         | 1991-1996    | NE-40   | NE-40   |   |
|             |              | NE-40P  | NE-40P  |   |
| AMAZON 140  | -1973        | NE-13   | UN-4  |   |
|             |              | NE-56   | UN-FP   |   |
|             |              |   | UN-FS   |   |
| FH 12       | 1997         | HU-DHP  | HU-DHP  |   |
| PV AMAZON   | -            | AS-11   | HUD-1   |   |
|             |              | AS-24   |   |   |
| WARTBURG    | MODELOS      | -   | DOB-1   | DOB-1   |
|             |              |   | DOB-1D  | DOB-1D  |
|             |              |   | DOB-2   | DOB-2   |
|             |              |   | DOB-2D  | DOB-2D  |
|             |              |   | DOB-3   | DOB-3   |
|             |              |   | DOB-3D  | DOB-3D  |

| MARCA BRAND  | MODELO MODEL |  |  |  |
|--------------|--------------|---|---|---|
| YUGO-ZASTAVA | 101          | 1971-1982   | FO-FR   | IMS-3   |
|              | 311          | 1971-1982   | FO-FRP  | IMS-3P  |
|              | 411          | 1971-1982   |   | IMS-5   |
|              | 413          | 1971-1982   |   | IMS-5P  |
|              | 511          | 1971-1982   |   |   |
|              | 513          | 1971-1982   |   |   |
|              | KORAL        | 1987-   | FI-6I   | FI-3D   |
|              | YUGO 45      | 1987-   | FI-6IP3   | FI-3DP  |
|              | YUGO 55      | 1987-   |   | FI-3DP5   |
|              | YUGO 65      | 1987-   |   |   |
|              | YUGO 45      | 1982-1984   | FI-6I   | FI-6I   |
|              | YUGO 55      | 1982-1984   | FI-6IP3   | FI-6IP3   |
|              |              |   | FO-E-TC   | IMS-3   |
|              |              |   | FO-E-TCP  | IMS-3P  |
|              |              |   | FO-FR   | IMS-5   |
|              |              |   | FO-FRP  | IMS-5P  |
|              |              |   |   | SIP-1   |
|              | YUGO 45      | 1985-1986   | FI-6I   | YU-1D   |
|              | YUGO 55      | 1985-1986   | FI-6IP3   |   |
|              | YUGO 65      | 1985-1986   |   |   |
| YUGO 45      | 1986-1987    | FI-6I   | IMS-3   |   |
| YUGO 55      | 1986-1987    | FI-6IP3   | IMS-3P  |   |
| YUGO 65      | 1986-1987    |   | IMS-5   |   |
|              |              |   | IMS-5P  |   |
| ZAZ          | 966          | -   | NE-3  | VOL-3   |
|              | 968 A        | -   | NE-3P   |   |
|              | 968 M        | -   | NE-3P1  |   |
|              |              |   | NE-3P2  |   |
|              | TAVRIA       | -   | NE-3  | AF-19   |
|              |              |   | NE-3P   | AF-19P  |
|              |              | NE-3P1  |   |   |
|              |              | NE-3P2  |   |   |

**CAMIÓN**

KAMIONA

TRUCKS

CAMION

LKW





**THE KEY TO EXCELLENCE**  
GLOBALLY UNLOCKING MILLIONS OF DOORS DAILY













### CAMIÓN

KAMIOIA • TRUCKS • CAMION • LKW

| MARCA BRAND | MODELO MODEL |  |  |  |
|-------------|--------------|---|---|---|
| ASTRA       | BM 64.26     | -   | AF-7I   | IMS-3   |
|             | BM 64.30     | -   | AF-7IP  | IMS-3P  |
|             | BM 64.36     | -   | AF-8D   | IMS-5   |
|             | BM 66.30     | -   | AF-8DP  | IMS-5P  |
|             | BM 66.36     | -   | AF-8I   |   |
|             | BM 201       | -   | AF-8IP  |   |
|             | BM 305       | -   | AF-9D   |   |
|             |              |   |   | AF-9DP  |
|             |              |   | AF-9I   |   |
|             |              |   | AF-9IP  |   |
| BEDFORD     | CF           | -1980   | LF-9  | UN-1FS  |
|             |              |   | LF-RO   |   |
|             |              |   | LF-ROP  |   |
|             |              |   | NE-10   |   |
|             |              |   | NE-10P  |   |
|             | CF           | 1980-   | NE-10   | UN-FT   |
|             | CF 2 250 D   | 1980-   | NE-10P  | WAS-6   |
|             | CF 2 350 D   | 1980-   |   | WAS-6P  |
| TL 560      | -            | NE-1  | LF-6  |   |
| TL 860      | -            | NE-10   |   |   |
| TL 1260     | -            | NE-10P  |   |   |
| TM          | -            | NE-1P   |   |   |
| BROCKWAY    | VARIOS       | 1966-   | BS-4D   | BS-4D   |
|             |              |   | YA-8D   | YA-8D   |
|             |              |   | YA-8I   | YA-8I   |
| DAF         | 2800         | -   | CHR-3   | FO-OA   |
|             | 3600         | -   | CHR-3P  |   |
|             | FA 2100 DT   | -   |   |   |
|             | FA 2105      | -   |   |   |
|             | FA 2505      | -   |   |   |
|             | FA 2805      | -   |   |   |
|             | FA 3605      | -   |   |   |
|             | FAS 3605     | -   |   |   |
|             | FAT 2826     | -   |   |   |
|             | FAT 3626     | -   |   |   |
|             | FT 2505      | -   |   |   |
|             | FT 2805      | -   |   |   |
|             | FT 3605      | -   |   |   |
|             | FTT 2826     | -   |   |   |
|             | FTT 3626     | -   |   |   |
|             | 2800 T. IN.  | -1984   | NE-3  | FO-OA   |
|             | FA 1100      | 1980-1982   | NE-3P   |   |
|             | FA 1300 T    | 1980-1982   | NE-3P1  |   |
|             | FA 2100      | 1980-1982   | NE-3P2  |   |
|             | FA 2500      | 1980-1982   |   |   |
|             | F 1100       | 1985-1991   | CHR-3   | FO-OA   |
|             | F 1300       | 1985-1991   | NE-22P2   |   |
|             | F 1700       | 1985-1991   |   |   |



| MARCA BRAND | MODELO MODEL |  |  |  |
|-------------|--------------|---|---|---|
| DAF         | F 1900       | 1985-1991   |   |   |
|             | F 2100       | 1985-1991   |   |   |
|             | F 2500       | 1985-1991   |   |   |
|             | F 3626       | 1985-1991   |   |   |
|             | FA 1100 DT   | -   | DAV-1   | RO-4D   |
|             | FA 1300 DNT  | -   | DAV-1P  | RO-4I   |
|             | FA 1300 DT   | -   |   |   |
|             | FA 2100      | 1982-1984   |   |   |
|             | FA 2500      | 1982-1984   |   |   |
|             | FA 2500      | -   | CHR-3   | FO-OA   |
|             |              |   | CHR-3P  |   |
|             |              |   | NE-3  |   |
|             |              |   | NE-3P   |   |
|             |              |   | NE-3P1  |   |
|             |              |   | NE-3P2  |   |
|             | F-FA-V- 600  | 1985-1991   | NE-11   | FO-OA   |
|             | F-FA-V- 800  | 1985-1991   | NE-11P  |   |
|             | F-FA-V-1000  | 1985-1991   |   |   |
| FT 75.270R  | -            | CHR-3   | VO-VB   |   |
| FT 85.360W  | -            | NE-22P  | VO-VBP  |   |
| FT 3300     | -            |   |   |   |
| SERIE FT    | 1991-        | CHR-3   | VO-VB   |   |
|             |              | CHR-3P  | VO-VBP  |   |
| V 400       | 1991-        | NE-11   | NE-11   |   |
| V 600       | 1991-        | NE-11P  | NE-11P  |   |
| DIAMOND REO | VARIOS       | 1960-   | HUD-1   | HUD-1   |
| FIAT IVECO  | 30.8         | -1991   | FI-11   | FI-11   |
|             | 35.10        | -1991   | FI-11P  | FI-11P  |
|             | 35.8         | -1991   | FI-1P   | FI-1P   |
|             | 40.10        | -1991   |   |   |
|             | 49.10        | -1991   |   |   |
|             | 30.8         | 1992-   | FI-12   | FI-11   |
|             | 35.10        | 1992-   | FI-12P1   | FI-11P  |
|             | 35.12        | 1992-   |   |   |
|             | 35.8         | 1992-   |   |   |
|             | 40.10        | 1992-   |   |   |
|             | 40 NC 35     | -   | AF-9D   | AF-5D   |
|             | 40.8 F 8     | -   | AF-9DP  | AF-5I   |
|             |              |   | AF-9I   | AF-6D   |
|             |              |   | AF-9IP  | AF-6I   |
|             | 50 NC        | -   | AF-9D   | IMS-3   |
| 55          | -            | AF-9DP  | IMS-3P  |   |
| 55 NC       | -            | AF-9I   | IMS-5   |   |
| 80 NC       | 1979-        | AF-9IP  | IMS-5P  |   |
|             |              | FEM-1D  |   |   |
|             |              | FEM-1I  |   |   |
| 50.10 F 10  | 1979-        | LF-RO   | IMS-3   |   |
| 55.8 F 8    | 1979-        | LF-ROP  | IMS-3P  |   |
| 60.10 F 10  | 1979-        | SIP-1   | IMS-5   |   |



| MARCA BRAND | MODELO MODEL |  |  |  |  |
|-------------|--------------|---|---|---|--|
| FIAT IVECO  | 65.10 F 10   | 1979-   |   | IMS-5P  |  |
|             | 70.10 F 10   | 1979-   |   |   |  |
|             | 79.10 F 10   | 1979-   |   |   |  |
|             | 79.13 F 13   | 1979-   |   |   |  |
|             | 79.14 F 14   | 1979-   |   |   |  |
|             | 80.13 F 13   | 1979-   |   |   |  |
|             | 95.14 F 14   | 1979-   |   |   |  |
|             | 100          | 1979-   |   |   |  |
|             | 50.9         | -1994   | FI-6I   | IMS-3   |  |
|             | 60.11        | -1994   | FI-6IP1   | IMS-3P  |  |
|             | 65.12        | -1994   | FI-9I   | IMS-5   |  |
|             | 79.14        | -1994   | FI-9IP  | IMS-5P  |  |
|             | 80.14        | -1994   |   |   |  |
|             | 95.14        | -1994   |   |   |  |
|             | 109.14       | -1994   |   |   |  |
|             | 110.17       | -1994   |   |   |  |
|             | 100          | 1981-   | AF-8D   | IMS-3   |  |
|             | 110          | 1981-   | AF-8DP  | IMS-3P  |  |
|             | 110 NC       | 1981-   | AF-8I   | IMS-5   |  |
|             | 110 P        | 1981-   | AF-8IP  | IMS-5P  |  |
|             | 130          | 1981-   | AF-9D   |   |  |
|             | 150.20       | 1981-   | AF-9DP  |   |  |
|             | 160 NC       | 1981-   | AF-9I   |   |  |
|             | 170 NC 35    | 1981-   | AF-9IP  |   |  |
|             |              |   | FEM-1D  |   |  |
|             |              |   | FEM-1I  |   |  |
|             | 115.17 D T.  | -1989   | FI-6I   | FI-6I   |  |
|             | 115.17 H     | -1989   | FI-6IP  | FI-6IP  |  |
|             | 135          | -1989   |   |   |  |
|             | 145.17 H T.  | -1989   |   |   |  |
|             | 175.24       | -1989   |   |   |  |
|             | 150 R.20     | -   | AF-9D   | FI-5D   |  |
|             | 150 T.20     | -   | AF-9DP  | FI-5I   |  |
|             | 159.20       | -   | AF-9I   | IMS-3   |  |
|             | 190          | -1989   | AF-9IP  | IMS-3P  |  |
|             | 190 T.30     | -1989   |   | IMS-5   |  |
|             | 190.26       | -1989   |   | IMS-5P  |  |
|             | 180          | -1989   | AF-7I   | IMS-3   |  |
|             | 180.26       | -1989   | AF-7IP  | IMS-3P  |  |
|             | 180.26 T     | -1989   | AF-9D   | IMS-5   |  |
|             | 190.38       | -1989   | AF-9DP  | IMS-5P  |  |
|             | 190.38 T     | -1989   | AF-9I   |   |  |
|             | 190.F 35     | -1989   | AF-9IP  |   |  |
|             | 190.H 35     | -1989   |   |   |  |
|             | 190 PC 26    | -   | BH-2  | PRE-1I  |  |
| 260         | -            |   |   |   |  |
| 190 TURBOS. | 1989-1991    | AU-1  | FI-11   |   |  |
|             |              | AU-HV   | FI-11P  |   |  |
|             |              | AU-HVP  |   |   |  |
| 190.26      | -1991        | FI-11   | NE-1  |   |  |
| 190.30      | -1991        | FI-11P  | NE-1P   |   |  |
| 190.32      | -1991        |   |   |   |  |
| 190.36      | -1991        |   |   |   |  |
| 190.42      | -1991        |   |   |   |  |



| MARCA BRAND | MODELO MODEL |  |  |  |  |
|-------------|--------------|---|---|---|--|
| FIAT IVECO  | 190.48       | -1991   |   |   |  |
|             | 240.26       | -1991   |   |   |  |
|             | 240.32       | -1991   |   |   |  |
|             | 240.36       | -1991   |   |   |  |
|             | 280.36       | -1991   |   |   |  |
|             | 330.30       | -1991   |   |   |  |
|             | 330.35       | -1991   |   |   |  |
|             | 330.36       | -1991   |   |   |  |
|             | 190.26       | 1992-   | FI-11   | FI-11   |  |
|             | 190.30       | 1992-   | FI-11P  | FI-11P  |  |
|             | 190.32       | 1992-   |   |   |  |
|             | 190.36       | 1992-   |   |   |  |
|             | 190.42       | 1992-   |   |   |  |
|             | 190.48       | 1992-   |   |   |  |
|             | 240.26       | 1992-   |   |   |  |
|             | 240.32       | 1992-   |   |   |  |
|             | 240.36       | 1992-   |   |   |  |
|             | 280.36       | 1992-   |   |   |  |
|             | 330.30       | 1992-   |   |   |  |
|             | 330.35       | 1992-   |   |   |  |
|             | 330.36       | 1992-   |   |   |  |
|             | 190.30       | -1989   | AF-7I   | FI-5D   |  |
|             |              |   | AF-7IP  | FI-5I   |  |
|             |              |   | AF-9D   | IMS-3   |  |
|             |              |   | AF-9DP  | IMS-3P  |  |
|             |              |   | AF-9I   | IMS-5   |  |
|             |              |   | AF-9IP  | IMS-5P  |  |
|             | 190.33 T.S.  | -1988   | VO-VB   | FI-11   |  |
|             | 190.38 T.S.  | -1988   | VO-VBP  | FI-11P  |  |
|             | 190.42 T.S.  | -1988   |   |   |  |
|             | 242 E-15     | 1985-   | FI-3D   | IMS-3   |  |
|             | 242 E-18     | 1985-   | FI-3DP3   | IMS-3P  |  |
|             |              |   |   | IMS-5   |  |
|             |              |   |   | IMS-5P  |  |
|             | 242.15       | -1984   | CT-1  | IMS-3   |  |
|             | 242.18       | -1984   | CT-1P   | IMS-3P  |  |
|             |              |   | CT-3  | IMS-5   |  |
|             |              |   | CT-3P   | IMS-5P  |  |
|             | 260.36       | 1992-   | FI-11   | VO-VB   |  |
|             | 260.48       | 1992-   | FI-11P  | VO-VBP  |  |
|             | 330 F 35     | -1988   | VO-VB   | IMS-3   |  |
|             | 330.26       | -1988   | VO-VBP  | IMS-3P  |  |
|             | 330.30       | -1988   |   | IMS-5   |  |
|             | 330.32       | -1988   |   | IMS-5P  |  |
|             | 330.35       | -1988   |   |   |  |
| 330.36      | -1988        |   |   |   |  |
| 619.3A      | -            | AF-9D   | AF-9D   |   |  |
| 619.N       | -            | AF-9DP  | AF-9DP  |   |  |
| 642         | -            | AF-9I   | AF-9I   |   |  |
|             |              | AF-9IP  | AF-9IP  |   |  |
| 643         | -            | AF-9D   | AF-5D   |   |  |
| 672         | -            | AF-9DP  | AF-5I   |   |  |
|             |              | FEM-1D  | AF-6D   |   |  |
|             |              | FEM-1I  | AF-6I   |   |  |



# CAMIÓN

## TRUCKS

| MARCA BRAND     | MODELO MODEL |  |  |  |
|-----------------|--------------|---|---|---|
| FORD            | A 0406       | -   | FO-E-TC   | UN-FT   |
|                 | A 0406 R     | -   | FO-E-TCP  |   |
|                 | A 0509       | -   | FO-TX   |   |
|                 | A 0509 P     | -   | FO-TXP  |   |
|                 | A 0609       | -   | UN-FT   |   |
|                 | D 710 CUSTOM | -   |   |   |
|                 | CARGO        | 1986-1991   | NE-11P3   |   |
| TRANSCONTIN.    | -            | LF-6  | LAS-R   |   |
|                 |              |   | LAS-V   |   |
| FORD (USA)      | CARGO        | 1986-   | NE-11P3   | NE-11P3   |
|                 | MODELOS      | -1973   | MAZ-14D   | MAZ-14D   |
|                 | MODELOS      | 1974-1984   | MAZ-1D  | MAZ-1D  |
|                 |              |   | MAZ-1I  | MAZ-1I  |
|                 | MODELOS      | 1986-1987   | NE-11   | LF-WR   |
|                 |              |   | NE-11P  |   |
|                 | MODELOS      | 1987-1988   | FO-11D  | FO-11D  |
|                 |              | FO-20D  | FO-20D  |   |
| MODELOS         | 1988-1995    | NE-11   | NE-11   |   |
|                 |              | NE-11P  | NE-11P  |   |
| MODELOS         | 1996-1997    | FO-15D  | FO-15D  |   |
|                 |              | FO-15DP   | FO-15DP   |   |
| FREIGHTLINER    | VARIOS       | -   | BS-4D   | BS-4D   |
|                 |              |   | HUD-1   | HUD-1   |
|                 |              |   | YA-8D   | YA-8D   |
| GM (CHEVRO-LET) | MODELOS      | 1972-1980   | TOYO-2  | TOYO-2  |
|                 | MODELOS      | 1981-1982   | MIT-1I  | MIT-1I  |
|                 |              |   | MIT-11P   | MIT-11P   |
|                 |              |   | MIT-2I  | MIT-2I  |
|                 |              | MIT-2IP   | MIT-2IP   |   |
| GM (GMC)        | MEDIUM       | 1984-1986   | DAT-6D  | DAT-6D  |
|                 | TRUCK W4     | 1984-1986   | DAT-6DP1  | DAT-6DP1  |
|                 | MEDIUM       | 1986-   | ISU-2   | ISU-2   |
|                 | TILTMAS-TER  | 1986-   |   |   |
| TRUCK W4        | 1986-        |   |   |   |
| HINO            | MODELOS      | 1976-   | TOYO-K1   | TOYO-K1   |
|                 |              |   | TOYO-K1P  | TOYO-K1P  |
| ISUZU           | NKR          | -   | MIT-15P   | MIT-15P   |
|                 | NPR          | -   |   |   |
|                 | NQR          | -   |   |   |
|                 | TILTMAS-TER  | 1986-1988   | DAT-6D  | DAT-6D  |
|                 | W4-W5 (S.N)  | 1986-1988   | DAT-6DP1  | DAT-6DP1  |
|                 |              | ISU-1   | ISU-1   |   |
|                 |              | ISU-2   | ISU-2   |   |
| KENWORTH        | MIDRANGER    | 1988-   | NE-11   | NE-11   |
|                 |              |   | NE-11P  | NE-11P  |
| MACK            | MIDLINER     | 1982-   | BH-1  | RO-4I   |
|                 |              |   | BH-1P   |   |
|                 |              |   | DAV-1   |   |
|                 |              |   | DAV-1P  |   |
|                 | MODELOS      | 1955-1986   | BS-1I   | BS-1I   |
|                 |              | YA-11D  | YA-11D  |   |
| MAGIRUS DEUTZ   | 90 M 5.3     | -   | BH-1  | RO-4D   |
|                 | 90 M 6.0     | -   | BH-1P   | RO-4I   |
|                 | 90 M 6.6     | -   |   |   |



| MARCA BRAND   | MODELO MODEL |  |  |  |
|---------------|--------------|---|---|---|
| MAGIRUS DEUTZ | 90 M 7       | -   |   |   |
|               | 90 M 9       | -   |   |   |
|               | 130 M 11     | -   |   |   |
|               | 130 M 13     | -   |   |   |
|               | 130 M 16     | -   |   |   |
|               | 130 M 9      | -   |   |   |
|               | 160 M 13     | -   |   |   |
| 260           | -            | BH-2  | PRE-1I  |   |
| 360 D 18      | -            |   |   |   |
| MAN           | 6.100 F      | -   | VO-R  | VO-R  |
|               | 6.90 F       | -   | VO-RP   | VO-RP   |
|               | 8.136 F      | -   |   |   |
|               | 8.90 F       | -   |   |   |
|               | 9.136        | -   |   |   |
|               | 9.136 F      | -   |   |   |
|               | 9.136 FAE    | -   |   |   |
|               | 9.150 F      | -   |   |   |
|               | 10.136       | -   |   |   |
|               | 10.150 F     | -   |   |   |
|               | 12.170       | -   | BH-1  | HU-MN   |
|               | 12.192 F-FT  | -   | BH-1P   | HU-MNP  |
|               | 12.192 FKT   | -   |   |   |
|               | 12.232 FT    | -   |   |   |
|               | 14.192 F     | -   |   |   |
|               | 14.232 FKT   | -   |   |   |
|               | 14.232 FT    | -   |   |   |
|               | 17.232 F     | -   |   |   |
|               | 18.272 FTI   | -   |   |   |
|               | 19.240 F     | -   |   |   |
|               | 19.262 F     | -   |   |   |
|               | 19.321 F-F/2 | -   |   |   |
|               | 19.322 F-FK  | -   |   |   |
| 19.322 FLT    | -            |   |   |   |
| 19.361 F-FT   | -            |   |   |   |
| 19.361-T      | -            |   |   |   |
| 19.363 F      | -            |   |   |   |
| 19.372 FAK    | -            |   |   |   |
| 19.422 F-FT   | -            |   |   |   |
| 19.462 F      | -            |   |   |   |
| 19.502 F-FLT  | -            |   |   |   |
| 22.361        | -            |   |   |   |
| 24.362        | -            |   |   |   |
| 25.372 FNL    | -            |   |   |   |
| 25.422 FNL    | -            |   |   |   |
| 33.222 DF     | -            |   |   |   |
| 33.240        | -            |   |   |   |
| 33.281-T      | -            |   |   |   |
| 33.292        | -            |   |   |   |
| 33.362        | -            |   |   |   |
| 33.365        | -            |   |   |   |
| 33.372 DF     | -            |   |   |   |
| 33.372 DFA    | -            |   |   |   |
| 33.422 DF     | -            |   |   |   |
| 33.422 DFA    | -            |   |   |   |



| MARCA BRAND          | MODELO MODEL |  |  |  |
|----------------------|--------------|---|---|---|
| MAN                  | 40.440       | -   |   |   |
|                      | 41.372 VFK   | -   |   |   |
|                      | 41.422 VFK   | -   |   |   |
|                      | 33.320       | -   | BH-1  | HU-SX   |
|                      |              |   | BH-1P   |   |
| MERCEDES (ARGENTINA) | MODELOS      | -   | ME-9P   | ME-9P   |
|                      | MODELOS      | 1990  | ME-13DP   | ME-13DP   |
|                      |              |   | ME-14P  | ME-14P  |
| MITSUBISHI           | FUSO         | -1985   | MIT-2I  | MIT-2I  |
|                      |              |   | MIT-2IP   | MIT-2IP   |
|                      | FUSO         | 1985-   | MIT-10  | MIT-10  |
|                      |              |   | MIT-11D   | MIT-11D   |
|                      |              |   | MIT-9   | MIT-9   |
| NISSAN               | L.35         | -1993   | DAT-6   | DAT-6   |
|                      | M 115.17     | -1993   | DAT-6P  | DAT-6P  |
|                      | L.35.08      | -1993   | CHR-3   | DAT-6   |
|                      |              |   | NE-22P  | DAT-6P  |
|                      | L.70.09      | -1993   | CHR-5   | DAT-6   |
|                      | L.80.14      | -1993   |   | DAT-6P  |
|                      | MODELOS      | 1980-   | DAT-12  | DAT-12  |
|                      |              | DAT-6   | DAT-6   |   |
|                      |              | DAT-6P  | DAT-6P  |   |
| PEGASO               | 360          | -   | AU-1  | CHR-3   |
|                      |              |   | AU-HV   | CHR-3P  |
|                      |              |   | AU-HVP  | NE-22P1   |
|                      |              |   | VO-HV   |   |
|                      |              |   | VO-HVP  |   |
|                      | 620          | -   | CHR-3   | VO-VB   |
|                      |              |   | CHR-3P  | VO-VBP  |
|                      | 1236         | -   | CHR-5   | IMS-5   |
|                      |              |   |   | IMS-5P  |
|                      |              |   |   |   |
| PIAGGIO              | APE CAR      | -   | AF-9D   | FAB-1   |
|                      | APE CAR P3   | -   | AF-9DP  |   |
|                      | P 601        | -   | AF-9I   |   |
|                      |              |   | AF-9IP  |   |
|                      |              |   | FAB-1   |   |
|                      |              |   | FEM-1D  |   |
|                      |              |   | FEM-1I  |   |
|                      | APE P 50     | -   | FEM-1D  |   |
|                      | APE TM P 50  | -   | FEM-1I  |   |
|                      |              |   | NE-6  |   |
|                      |              |   | NE-6P   |   |
|                      | APE TM 703   | -   | AF-9D   | FAB-1   |
|                      | NICA 125     | -   | AF-9DP  |   |
|                      |              | AF-9I   |   |   |
|                      |              | AF-9IP  |   |   |
|                      |              | FAB-1   |   |   |
| RENAULT SAVIEM       | B 70.35      | -1987   | CHR-3   | VA-7  |
|                      | B 70.45      | -1987   | CHR-3P  |   |
|                      | B 90.35      | -1987   | LMP-5   |   |
|                      | MASTER P35 D | -1987   | LMP-5P1   |   |
|                      | MASTER T30 D | -1987   | NE-22P  |   |
|                      | MASTER T35 D | -1987   |   |   |
|                      | B 70.45      | 1988-1992   | CHR-3   | NE-28   |
|                      |              |   |   |   |

| MARCA BRAND    | MODELO MODEL |  |  |  |
|----------------|--------------|---|---|---|
| RENAULT SAVIEM | B 80.45      | 1992-   | NE-22P  |   |
|                | B 90.45      | 1988-1992   |   |   |
|                | B 90.50      | 1988-1992   |   |   |
|                | B 110.150    | 1992-   |   |   |
|                | B 110.35     | 1992-   |   |   |
|                | MASTER T30 D | 1987-   |   |   |
|                | MASTER T35 D | 1987-   |   |   |
|                | MASTER TURBO | 1987-   |   |   |
|                | G 300 G      | -1994   | DAV-1   | LAS-R   |
|                | G 330 GV     | -1994   | DAV-1P  | LAS-V   |
|                | G 340 TI     | -1994   | NE-3  |   |
|                | GR 305       | -1994   | NE-3P   |   |
|                | GR 305 TURBO | -1994   | NE-3P1  |   |
|                | R 310        | 1984  | NE-3P2  |   |
|                | R 360        | 1984-1985   |   |   |
|                | R 360 TURBO  | 1984  |   |   |
|                | GB 119       | 1986  | DAV-1   | RO-4D   |
|                | GB 231 TURBO | 1986  | DAV-1P  | RO-4I   |
|                | GC 231 TURBO | 1986  |   |   |
|                | GF 231 TURBO | 1986  |   |   |
|                | GR 231 TURBO | 1986  |   |   |
|                | JK 50-60     | -   | BH-1  | RO-15   |
|                | JK 75-90     | -   | BH-1P   | RO-4D   |
|                | JK 110-115   | -   |   | RO-4I   |
|                | JP 11        | -   | BH-1  | RO-4D   |
|                | JP 13        | -   | BH-1P   | RO-4I   |
|                | JP 13 TU     | -   |   |   |
|                | JP 115       | -   |   |   |
| M 160.12       | -1994        | NE-3  | VA-10   |   |
| M 200.12       | -1994        | NE-3P   |   |   |
| M 230.12       | -1994        | NE-3P2  |   |   |
| M 230.13T      | -1994        |   |   |   |
| M 230.16       | -1994        |   |   |   |
| R 350 TI       | -1992        |   |   |   |
| R 365          | -1992        |   |   |   |
| R 380          | -1992        |   |   |   |
| R 385          | -1994        |   |   |   |
| R 420          | -1992        |   |   |   |
| RI 357         | -1992        |   |   |   |
| R 360          | 1985-1987    | NE-3  | LAS-R   |   |
| R 370          | 1985-1987    | NE-3P   | LAS-V   |   |
| R 370 T U8 T   | 1985-1987    | NE-3P2  |   |   |
| S 100.06       | -1994        | NE-3  | RO-4I   |   |
| S 100.07       | -1994        | NE-3P   |   |   |
| S 100.08 T.    | -1994        | NE-3P2  |   |   |
| S 150          | -1994        |   |   |   |
| S 160.08 T     | -1994        |   |   |   |
| S 160.09       | -1994        |   |   |   |
| S 170.13       | -1994        |   |   |   |
| S 170.145      | -1994        |   |   |   |
| SG2/35-40      | -            | BH-1  | LAS-R   |   |
| SG3/35-40      | -            | BH-1P   | LAS-V   |   |
| SG4/35-40      | -            |   |   |   |
| TRAFFIC        | -1987        | CHR-3   | RO-17   |   |

# CAMIÓN

## TRUCKS

| MARCA BRAND    | MODELO MODEL |  |  |  |                                    |
|----------------|--------------|---|---|---|------------------------------------|
| RENAULT SAVIEM |              |   | CHR-3P<br>NE-22P  |   |                                    |
|                | TRAFFIC      | 1988-   | NE-19<br>NE-19P   | NE-28   |                                    |
| ROVER          | LEYLAND ROAD | -   | NE-11<br>NE-11P   | LAS-V   |                                    |
| SCANIA         | 110          | -   | BH-2  | HU-SX   |                                    |
|                | 111          | -   | FO-FR   |   |                                    |
|                | 140 8V T     | -   | FO-FRP  |   |                                    |
|                | 141          | -   | WAS-2P  |   |                                    |
|                | 411 8V       | -   |   |   |                                    |
|                | 112 H        | -1987   | VO-VB   | WIT-1   |                                    |
|                | 142 H 8V     | -1987   | VO-VBP  |   |                                    |
|                | P 82         | -1987   |   |   |                                    |
|                | P 92         | -1987   |   |   |                                    |
|                | P 93 H-HL    | 1988-   |   |   |                                    |
|                | P 93 ML      | 1988-   |   |   |                                    |
|                | P 113 EL     | 1988-   |   |   |                                    |
|                | R 112 H      | -1987   |   |   |                                    |
|                | R 113 E-ES   | 1988-   |   |   |                                    |
|                | R 113 HL-HS  | 1988-   |   |   |                                    |
|                | R 113 M      | 1988-   |   |   |                                    |
|                | R 113 MA     | 1988-   |   |   |                                    |
|                | R 142 E      | -1987   |   |   |                                    |
|                | R 142 H      | -1987   |   |   |                                    |
|                | R 142 H 8V   | -1987   |   |   |                                    |
| R 142 M        | -1987        |   |   |   |                                    |
| R 143 EL-ES    | 1988-        |   |   |   |                                    |
| R 143 HL-HS    | 1988-        |   |   |   |                                    |
| R 143 MA       | 1988-        |   |   |   |                                    |
| R-144 NA       | 1996-        | HU-2P   | HU-2P   |   |                                    |
| STEYR PUCH     | 10 S 14      | -   | VO-VB   | AKS-1   |                                    |
|                | 17 S 18      | -   | VO-VBP  |   |                                    |
|                | 19 S 31      | -   | NE-25   |   |                                    |
|                | 19 S 37      | -   |   |   |                                    |
|                | 26 S 31      | -   |   |   |                                    |
|                | 32 S 31      | -   |   |   |                                    |
| TRUCK (USA)    | MODELOS      | 1995  | GM-14<br>GM-14P<br>GM-25<br>GM-25P  | GM-14<br>GM-14P<br>GM-25<br>GM-25P  |                                    |
|                | VOLKSWAGEN   | MODELOS   | 1981-1984   | VO-VB<br>VO-VBP   | VO-VB<br>VO-VBP                    |
|                |              |   | 1984-   | VO-HV<br>VO-HVP<br>VO-VB<br>VO-VBP  | VO-HV<br>VO-HVP<br>VO-VB<br>VO-VBP |
|                | VOLVO        | F 6   | -   | NE-12   | NE-12                              |
| F 7            |              | -   | NE-12P  | NE-12P  |                                    |
| F 10           |              | -   |   |   |                                    |
| F 12 T 6       |              | -   |   |   |                                    |
| F 1020 T 6     |              | -   | NE-3<br>NE-3P<br>NE-3P2   | NE-12<br>NE-12P   |                                    |

| MARCA BRAND | MODELO MODEL |  |  |  |
|-------------|--------------|---|---|---|
| VOLVO       | FL 6 INTER.  | -   | NE-12   | RO-4D   |
|             | FL 7 INTER.  | -   | NE-12P  | RO-4I   |
|             | FL 10 INTER. | -   |   |   |
|             | FL 12 INTER. | -   |   |   |
|             | FL 611       | -   | NE-12   |   |
|             | FL 614       | -   | NE-12P  |   |
| FL 616      | -            |   |   |   |
| MODELOS     | -1987        | NE-1<br>NE-1P   | NE-1<br>NE-1P   |   |
| WHITE       | VARIOS       | -1980   | BS-4D<br>HUD-1  | BS-4D<br>HUD-1  |
|             | VARIOS       | -1989   | BS-2<br>BS-5  | BS-2<br>BS-5  |



**MOTOCICLETA**

MOTOZIKLETA  
MOTORCYCLE  
MOTOCYCLETTE  
MOTORRAD

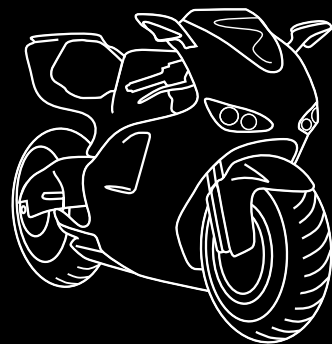



**THE KEY TO EXCELLENCE**  
GLOBALLY UNLOCKING MILLIONS OF DOORS DAILY













### MOTOCICLETA

MOTOZIKLETA • MOTORCYCLE • MOTOCYCLETTE • MOTORRAD

| MARCA<br>BRAND | MODELO<br>MODEL |  |  |  |
|----------------|-----------------|---|---|---|
| APRILIA        | AFI 50          | 1986-1991   | ZA-1  | ZA-1  |
|                | AFI 125         | 1986-1991   | ZA-1P   | ZA-1P   |
|                | AS 125 R.V.     | 1986-1991   |   |   |
|                | ET 50           | 1986-1991   |   |   |
|                | ETX 125 PV      | 1986-1991   |   |   |
|                | ETX 350         | 1986-   |   |   |
|                | ETX 600         | 1986-   |   |   |
|                | EUROPA 125AE    | 1992-   |   |   |
|                | EXTREMA 125     | 1993-   |   |   |
|                | MX 125 A        | 1986-1991   |   |   |
|                | PEGASO 125      | 1993-1994   |   |   |
|                | RED ROSE 50     | 1986-1990   |   |   |
|                | RED ROSE 125    | 1986-1990   |   |   |
|                | RED ROSE 125    | 1993-1994   |   |   |
|                | RX 125          | 1992-   |   |   |
|                | TUAREG 125      | 1986-1991   |   |   |
|                | AMICO           | 1996-1998   | ZA-6DP1   | ZA-6DP1   |
|                | AREA 51         | 1998-2000   |   |   |
|                | CLASSIC 50      | 1996-1999   |   |   |
|                | CLASSIC 125     | 1996-1999   |   |   |
|                | ETV 1000 C.     | 2001-2007   |   |   |
|                | GULLIVER        | 1995-1998   |   |   |
|                | LEONARDO        | 1996-2004   |   |   |
|                | MOJITO          | 1999-2008   |   |   |
|                | MOTO 6.5        | 1996-2002   |   |   |
|                | MX              | 2002-2006   |   |   |
|                | PEGASO          | 1997-2004   |   |   |
|                | PEGASO 3-650    | 1996-   |   |   |
|                | RALLY           | 1996-2004   |   |   |
|                | RS              | 1996-2005   |   |   |
|                | RST FUTURA      | 2000-2003   |   |   |
|                | RSV 1000        | 1998-2005   |   |   |
|                | RX 50           | 1996-2004   |   |   |
|                | SCARABEO        | 1993  |   |   |
|                | SL 1000 F.      | 2000-2003   |   |   |
|                | SONIC 50        | 1998-2008   |   |   |
|                | SPORTCITY       | 2004  |   |   |
|                | SR 125-150      | 1999-2001   |   |   |
|                | SR 50           | 1996-2004   |   |   |
|                | AMICO 50        | 1992-   | ZA-4DP  | ZA-4DP  |
|                | CLIMBER 280     | 1994-   |   |   |
|                | EUROPA 50       | 1992-   |   |   |
|                | EUROPA 125      | 1994-   |   |   |
|                | FUTURA 50       | 1990-1991   |   |   |
|                | FUTURA 50AE     | 1992-   |   |   |
|                | PEGASO 50       | 1992-   |   |   |
|                | PEGASO 125      | 1994-   |   |   |
|                | PEGASO 600      | 1990-   |   |   |
|                | PEGASO 650      | 1990-   |   |   |



| MARCA<br>BRAND | MODELO<br>MODEL |  |  |  |
|----------------|-----------------|---|---|---|
| APRILIA        | RED ROSE 50     | 1992-   |   |   |
|                | RED ROSE 125    | 1994-   |   |   |
|                | RS 50 EXTRE.    | 1992-   |   |   |
|                | RX 50           | 1992-1996   |   |   |
|                | RX 125 EXT.     | 1994-   |   |   |
|                | RX 125 REP.     | 1994-   |   |   |
|                | SIX DAYS RX     | 1990-1991   |   |   |
|                | SR 50           | 1992-1996   |   |   |
|                | TUAREG R. 50    | 1994-   |   |   |
|                | ATLANTIC 125    | 2003  | ZA-9P1  | ZA-9P1  |
|                | FILO GT 4L      | -   | AF-8D   |   |
|                | MX 250          | -   | AF-8DP  |   |
|                | RC 250          | -   | AF-8I   |   |
|                |                 |   | AF-8IP  |   |
|                |                 |   | FEM-2D  |   |
|                |                 |   | FEM-2I  |   |
|                | FUTURA 50AE     | 1990-1991   | ZA-13P  |   |
|                | RX 50           | 1990-1991   |   |   |
|                | FUTURA 125      | 1990-1991   | ZA-2P   |   |
|                | REPLICA 50      | 1990-1991   |   |   |
|                | RALLY 125       | 1990-1991   | ZA-1  | NE-8  |
|                | RX 125          | 1990-1991   | ZA-1P   |   |
|                | RED ROSE 50     | 1990-1991   | FI-11   | ZA-1  |
|                |                 |   | FI-11P  | ZA-1P   |
|                |                 |   | ZA-2P   |   |
|                | TUAREG 125      | 1992-   | ZA-2P   | ZA-2P   |
|                | TUAREG 250      | 1986-   | ZA-1  | NE-8  |
|                | TUAREG 350      | 1986-   | ZA-13P  |   |
|                | TUAREG 600      | 1986-   | ZA-1P   |   |
| ATALA          | BYTE AT10-50    | 1996  | ZA-4DP  | ZA-4DP  |
|                | GREEN           | 1996  |   |   |
|                | HAKER           | 1996  |   |   |
| BENELLI        | 124             | -   | FEM-1D  |   |
|                | 125 TURISMO     | -   | FEM-1I  |   |
|                | 125 SPORT       | 1982-1983   |   | NE-8  |
|                | 125 SPORT       | 1983-1984   | FEM-2D  | NE-6  |
|                | T 125           | -   | FEM-2I  | NE-6P   |
|                | 125 SPORT       | 1984-   | FEM-2D  | NE-8  |
|                | 125 TURISMO     | 1984-   | FEM-2I  |   |
|                | 250 2C          | -   |   | ZA-1  |
|                | 304 4C          | -   |   | ZA-1P   |
|                | 354             | -   |   |   |
|                | 654             | -   |   |   |
|                | 750 SEI         | -   |   |   |
|                | 900 SEI         | -   |   |   |
|                | EXPORT 3V       | -   |   |   |
|                | G2              | -   |   |   |
|                | LASER           | -   |   |   |
|                | MAGNUM 3V       | -   |   |   |



| MARCA BRAND | MODELO MODEL     |  |  |  |
|-------------|------------------|---|---|---|
| BENELLI     | MOTORELLA 50     | -   |   |   |
|             | S 50             | 1985-   |   |   |
|             | S 125            | -   |   |   |
| BETA        | 50 CC            | -1993   | AF-5I   | ZA-1<br>ZA-1P   |
|             | ALP              | -   | ZA-9P1  |   |
|             | RR               | 2005  |   |   |
|             | CHRONO           | 1995  | ZA-4DP  |   |
|             | CHRONO 502       | 1995  |   |   |
|             | QUADRA           | 1995  |   |   |
|             | TEMPO            | 1995  |   |   |
|             | KR 50            | -   | FAB-1   | FAB-1   |
|             | KR 125           | -   |   |   |
|             | KR 250           | -   |   |   |
|             | VRS 50           | -   |   |   |
|             | QUADRA           | 1996-   | ZA-6DP1   | ZA-6DP1   |
|             | TEMPO            | 1996-   |   |   |
|             | BICICLETE-CYCLES | MOD.DANES DK  | -   |   |
| MOD.SUECO S |                  | -   |   | AS-21<br>AS-21D<br>AS-2D<br>AS-2I   |
| RALEIGH     |                  | -   |   | LF-2<br>UN-FP   |
|             |                  |   |   |   |
|             |                  |   |   |   |
|             |                  |   |   |   |
| BIMOTA      | GPI 1            | 1990-   | ZA-1<br>ZA-1P   | ZA-1<br>ZA-1P   |
|             | HB 2             | -   | NE-6  | NE-6  |
|             | HB 3             | -   | NE-6P   | NE-6P   |
|             | HB 3/S           | -   |   |   |
|             | KB 1             | -   | SUZU-13P  | NE-6  |
|             | KB 2/TT          | -   | SUZU-4I<br>SUZU-4IP   | NE-6P   |
|             | SB 2             | -   | SUZU-13P<br>SUZU-4I<br>SUZU-4IP   |   |
|             | SB 3             | -   | SUZU-5  | NE-6  |
|             | SB 4S            | -   | SUZU-5P   | NE-6P   |
|             | SB 4SP           | -   |   |   |
| BMA         | AMICA 50         | -   | AF-9D   | UN-MRN  |
|             | AMICA 125        | -   | AF-9DP  |   |
|             | AMICA 250        | -   | AF-9I   |   |
|             | AMICA 360        | -   | AF-9IP<br>FEM-1D<br>FEM-1I  |   |
|             |                  |   |   |   |
| BMW         | 400 RS           | 1984-1985   | NE-6<br>NE-6P   | NE-6<br>NE-6P   |
|             | 450              | 1984-1986   | NE-7  | NE-7  |
|             | 650              | 1984-1986   |   |   |
|             | K 1              | 1987-1993   |   |   |
|             | K 75             | 1984-1992   |   |   |
|             | K 75 RT          | 1993-   |   |   |
|             | K 75 S           | 1993-   |   |   |
|             | K 100            | 1984-1992   |   |   |
|             | K 100 RS         | 1993-   |   |   |
|             |                  |   |   |   |
|             |                  |   |   |   |



| MARCA BRAND | MODELO MODEL |  |  |  |
|-------------|--------------|---|---|---|
| BMW         | K 1100 LT    | 1993-1994   |   |   |
|             | K 1100 RS    | 1993-1994   |   |   |
|             | R 45         | 1984-1986   |   |   |
|             | R 65         | 1984-1992   |   |   |
|             | R 80         | 1984-   |   |   |
|             | R 80 GS      | 1993-   |   |   |
|             | R 80 R       | 1993-   |   |   |
|             | R 80 RT      | 1993-   |   |   |
|             | R 100 GS     | 1993-   |   |   |
|             | R 100 R      | 1993-   |   |   |
|             | R 100 RS     | 1993-   |   |   |
|             | R 100 RT     | 1993-   |   |   |
|             | F 650        | 1994-   | ZA-6DP  |   |
|             | K 1100       | 1994-1995   | BM-HBP1   | BM-HBP1   |
|             | K 1100       | 1995  |   |   |
|             | K 1100 LS    | 1994-   |   |   |
|             | K 1100 LT    | 1994-   |   |   |
|             | R 850 RT     | 1996-2002   |   |   |
|             | R 1000       | 1995  |   |   |
|             | R 1100       | 1994-1995   |   |   |
|             | R 1100       | 1995  |   |   |
|             | R 1100 GS    | 1994-   |   |   |
|             | R 1100 R     | 1994-   |   |   |
| R 1100 RT   | 1994-        |   |   |   |
| R 60/6      | -            | NE-7  | NE-6  |   |
| R 60/7      | -            |   | NE-6P   |   |
| R 75/6      | -            |   |   |   |
| R 75/7      | -            |   |   |   |
| R 80/7      | -            |   |   |   |
| R 90 S      | -            |   |   |   |
| R 90/6      | -            |   |   |   |
| R 100 RS    | -            |   |   |   |
| R 100/7     | -            |   |   |   |
| R 100/S     | -            |   |   |   |
| BUELL       | BLAST        | 2000-2009   | ZA-9P1  |   |
|             | FIREBOLT     | 2002-2009   |   |   |
|             | LIGHTNING    | 2003-2009   |   |   |
|             | ULYSSES      | 2006-2009   |   |   |
| CAGIVA      | 125 ALETA    | 1986-   |   | ZA-1  |
|             | 200 ELEFANT  | 1984-   |   | ZA-1P   |
|             | 350 ALA      | 1984-1987   |   |   |
|             | ALETA EL.125 | -   |   |   |
|             | COCIS 50     | -1991   |   |   |
|             | CRESTA 350   | 1984-1987   |   |   |
|             | DG 350       | 1984-1987   |   |   |
|             | RX 250       | 1984-   |   |   |
|             | SST 250 ALA  | 1984-   |   |   |
|             | SST 250 RL   | 1984-   |   |   |
|             | SST 350 RL   | 1984-1987   |   |   |
|             | SX 250       | 1984-   |   |   |
|             | SX 350       | 1984-1987   |   |   |
|             | SXT 250      | 1984-   |   |   |
|             | WMX 250      | 1984-   |   |   |
| WMX 500     | 1984-        |   |   |   |



# MOTOCICLETA

## MOTORCYCLE

| MARCA BRAND  | MODELO MODEL |  |  |  |
|--------------|--------------|---|---|---|
| CAGIVA       | 650          | -   | SUZU-13P  | SUZU-13P  |
|              |              |   | SUZU-4I   | SUZU-4I   |
|              |              |   | SUZU-4IP  | SUZU-4IP  |
|              | 900 ELEFANT  | 1997  | KAW-6P  |   |
| ALETA ORO L. | 1986-        |   | FI-6I   | ZA-1  |
|              |              |   | FI-6IP2   | ZA-1P   |
|              |              |   | FI-6IP3   |   |
| ALETA ROSA   | 1986-        | SUZU-13P  | ZA-1  |   |
| AR 350       | 1984-1989    | SUZU-4I   | ZA-1P   |   |
| ELEFA. 2 125 | -            | SUZU-4IP  |   |   |
| ELEFA. 2 200 | -1984        |   |   |   |
| ELEFA. 2 350 | 1984-1989    |   |   |   |
| ELEFA. 2 600 | -            |   |   |   |
| K 3          | 1991-1992    |   |   |   |
| SST 125      | 1984-        |   |   |   |
| SXT 125 N    | 1984-        |   |   |   |
| W 8          | 1994         |   |   |   |
| BLUES 125    | -            | FI-1  | FI-1  |   |
| FRECCIA 125  | -            | FI-1P   | FI-1P   |   |
| FULL FUN 125 | -1990        |   |   |   |
| MITO 125     | -1990        |   |   |   |
| MMX 125      | -1990        |   |   |   |
| TAMANACO 125 | -            |   |   |   |
| CITY         | 1993-1994    | KAW-6P  | KAW-6P  |   |
| ELEFA. 900   | 1992-        |   |   |   |
| MITO         | 1992-        |   |   |   |
| MITO 125     | 1991-1992    |   |   |   |
| MITO CARENA. | 1991-1992    |   |   |   |
| MITO EV      | 1994-1995    |   |   |   |
| MITO LAWSON  | 1993-        |   |   |   |
| MITO RACING  | 1991-1994    |   |   |   |
| MITO RACING  | 1994         |   |   |   |
| PRIMA        | 1993-        |   |   |   |
| SUPER CITY   | 1993-        |   |   |   |
| CITY         | 1994-        | ZA-8P   | ZA-8P   |   |
| CITY LUCKY   | 1994-        |   |   |   |
| CITY PASSING | 1994-        |   |   |   |
| SUPERCITY    | 1994-        |   |   |   |
| ELEFA. 90    | -1991        | FI-1  | ZA-1  |   |
| ELEFA. 750   | -1991        | FI-1P   | ZA-1P   |   |
| FRECCIA 125  | 1991-1992    |   |   |   |
| LUCKY 350 E. | 1987-1991    |   |   |   |
| LUCKY 350 EX | -1991        |   |   |   |
| N 90         | 1991-1992    |   |   |   |
| PARIS DAKAR  | -1991        |   |   |   |
| T 350 E      | 1987-1991    |   |   |   |
| T4 350       | -1991        |   |   |   |
| T4 350 R     | 1987-1991    |   |   |   |
| T4 500 E     | -1991        |   |   |   |
| HD 175       | -            | FEM-1D  |   |   |
| HD 350       | -            | FEM-1I  |   |   |
| RIVER 600 C. | 1995-        | ZA-4DP  |   |   |
| ROADSTER 125 | 1994         | ZA-1  |   |   |
|              |              | ZA-1P   |   |   |



| MARCA BRAND  | MODELO MODEL |  |  |  |
|--------------|--------------|---|---|---|
| CAGIVA       | S.CITY 125   | 1992-   | ZA-4DP  | ZA-4DP  |
|              | SST-SX 125   | -1984   | FEM-1D  | ZA-1  |
|              | SST-SX 250   | -1984   | FEM-1I  | ZA-1P   |
|              | SST-SX 350   | -1984   |   |   |
|              | SXT 125      | 1984-   | SUZU-13P  |   |
|              |              |   | SUZU-4I   |   |
|              |              |   | SUZU-4IP  |   |
|              | TRIAL 125    | -   |   | CL-2I   |
|              | TRIAL 350    | -   |   | CL-3I   |
|              | W 12 350     | 1994  | ZA-1  | ZA-1  |
| W 16         | 1997         | ZA-1P   | ZA-1P   |   |
| CIMATTI      | GRINGO G1-4M | -   |   | ZA-1  |
|              | GRINGO LUX   | -   |   | ZA-1P   |
| DEMME        | SMILY        | -   |   | NE-6  |
|              |              |   |   | NE-6P   |
| DERBY        | ATLANTIS 100 | 2003-   | ZA-9P1  | ZA-9P1  |
|              | MULHACEN     | 2006-   |   |   |
|              | PREDATOR     | 1999  |   | ZA-9P1  |
| DKM-HERCULES | 125 G SPEC.  | -   |   | NE-6  |
|              | 175 GS       | -   |   | NE-6P   |
|              | 250 GS       | -   |   |   |
|              | 505 P        | -   |   |   |
|              | 531          | -   |   |   |
|              | 535 S        | -   |   |   |
| DUCATI       | 125 REG. 2T  | -   |   | NE-6  |
|              |              |   |   | NE-6P   |
|              | 250 SCRAMBL. | 1982-   | FEM-1D  | NE-6  |
|              | 350 GTV      | 1982-   | FEM-1I  | NE-6P   |
|              | 350 SCRAMBL. | 1982-   | FEM-2D  |   |
|              | 450 SCRAMBL. | 1982-   | FEM-2I  |   |
|              | 500 2 CIL.   | 1982-   |   |   |
|              | 500 GTL      | 1982-   |   |   |
|              | 500 SL PANT. | 1982-   |   |   |
|              | 750 GT-SS    | 1982-   |   |   |
|              | 750 SPORT    | 1982-   |   |   |
|              | 860 GT-GTS   | 1982-   |   |   |
|              | 900 2 CIL.   | 1982-   |   |   |
|              | 900 REPLICIA | 1982-   |   |   |
|              | 900 SD-SS    | 1982-   |   |   |
|              | 350 F3 DESMO | 1984-   | FEM-1D  | NE-8  |
|              | 350 GTL-XL   | 1984-   | FEM-1I  |   |
|              | 350 SL-TL    | 1984-   | FEM-2D  |   |
|              | 500 GTV-SL   | 1984-   | FEM-2I  |   |
|              | 500 SPORT D. | 1984-   |   |   |
| 600 SL-TL    | 1984-        |   |   |   |
| 900 DARMAH   | 1984-        |   |   |   |
| 350 SPORT    | 1993-        | KAW-6P  | KAW-6P  |   |
| 400 SPORT    | 1993-        |   |   |   |
| 600 S.SPORT  | 1994         |   |   |   |
| 750 SS       | 1991-1992    |   |   |   |
| 851 S        | 1991-1992    |   |   |   |
| 851 SPORT    | 1991-1992    |   |   |   |
| 888 RACING   | 1993-        |   |   |   |
| 888 S.P.4    | 1991-1992    |   |   |   |



| MARCA BRAND  | MODELO MODEL |  |  |  |  |
|--------------|--------------|---|---|---|--|
| DUCATI       | 888 S.P.5    | 1993-   |   |   |  |
|              | 900 M        | 1993-   |   |   |  |
|              | 900 S.L.     | 1991-   |   |   |  |
|              | 900 S.S.     | 1991-1992   |   |   |  |
|              | 900 SS       | 1991-   |   |   |  |
|              | 907 i.e.     | 1991-1992   |   |   |  |
|              | CARENATA     | 1991-   |   |   |  |
|              | CUPOLINO     | 1991-   |   |   |  |
|              | 600 MONSTER  | 1994-2001   | KAW-6P  |   |  |
|              | 748          | 1995-2003   |   |   |  |
|              | 750 S.SPORT  | 1999-2003   |   |   |  |
|              | 900 MONSTER  | 1994-2001   |   |   |  |
|              | 900 S.SPORT  | 1998-2002   |   |   |  |
|              | 996          | 1999-2004   |   |   |  |
|              | ST 2         | 1997-2003   |   |   |  |
|              | ST4          | 1998-2003   |   |   |  |
|              | 750 F1 DESMO | 1986-1991   | FEM-1D  | NE-8  |  |
|              |              |   | FEM-1I  |   |  |
|              |              |   | FEM-2D  |   |  |
|              |              |   | FEM-2I  |   |  |
|              |              |   | FI-6I   |   |  |
|              |              |   | FI-6IP3   |   |  |
|              | 750 F1 DESMO | 1987  | ZA-13P  | ZA-13P  |  |
|              | 851 SPORT    | 1989-1990   |   |   |  |
|              | 907 i.e.     | 1989-1990   |   |   |  |
|              | DESMO 900 SS | 1989-   |   |   |  |
|              | PASO 906     | 1989-   |   |   |  |
|              | 750 INDIANA  | 1990-1991   | FI-6I   | FI-6I   |  |
|              | 750 SPORT R  | 1990-1991   | FI-6IP3   | FI-6IP3   |  |
|              | PASO 750 LTD | 1990-1991   |   |   |  |
|              | 851 S        | 1990-1991   | FI-6I   | ZA-1  |  |
|              | 900 S.S.     | 1990-1991   | FI-6IP3   | ZA-1P   |  |
|              | 907 i.e.     | 1992  | ZA-4DP  | ZA-4DP  |  |
| INDIANA 350  | 1987-        |   | ZA-1  |   |  |
| INDIANA 650  | 1987-        |   | ZA-1P   |   |  |
| INDIANA 750  | 1987-        |   |   |   |  |
| PASO 350     | 1987-        | ZA-13P  | ZA-1  |   |  |
| PASO 750     | 1987-        |   | ZA-13P  |   |  |
|              |              |   | ZA-1P   |   |  |
| FANTIC MOTOR | 50.1 OASIS   | 1984-1991   |   | ZA-1  |  |
|              | CABALLERO    | 1992-   |   | ZA-1P   |  |
|              | CABALLERO 50 | 1984-1991   |   |   |  |
|              | CLAN 50      | 1982-   |   |   |  |
|              | CLUBMAN      | 1993-   |   |   |  |
|              | ISSIMO       | 1982-   |   |   |  |
|              | JOY 3V       | 1984-1991   |   |   |  |
|              | JOY MK       | 1984-1991   |   |   |  |
|              | JOY VK       | 1984-1991   |   |   |  |
|              | KOALA        | 1993-   |   |   |  |
|              | K-ROO        | 1992-   |   |   |  |
|              | RAIDER 50.1  | 1984-1991   |   |   |  |
|              | RAIDER 125LC | -   |   |   |  |
|              | RAILLY 240   | -   |   |   |  |
|              | TENTER TO    | 1984-1991   |   |   |  |



| MARCA BRAND  | MODELO MODEL |  |  |  |        |
|--------------|--------------|---|---|---|--------|
| FANTIC MOTOR | TRIAL 50     | 1982-   |   |   |        |
|              | TRIAL 201    | -1991   |   |   |        |
|              | TRIAL 240    | -1991   |   |   |        |
|              | TRIAL 241    | -1991   |   |   |        |
|              | TRIAL 242    | -1991   |   |   |        |
|              | TRIAL 245    | -1991   |   |   |        |
|              | TRIAL 300    | -1991   |   |   |        |
|              | TRIAL 301    | -1991   |   |   |        |
|              | TRIAL 303    | -1991   |   |   |        |
|              | TRIAL 305    | -1991   |   |   |        |
|              | TRIAL KID    | 1984-1991   |   |   |        |
|              | TRIAL S.5    | 1984-1991   |   |   |        |
|              | TRIAL S.7    | 1984-1991   |   |   |        |
|              | 125          | 1984-   | ZA-1  | ZA-1  |        |
|              | 125 SPORT    | 1984-   | ZA-1P   | ZA-1P   |        |
|              | ISSIMO 50    | 1984-   |   |   |        |
|              | RAIDER 50    | 1984-   |   |   |        |
|              | RAIDER GT 50 | 1984-   |   |   |        |
|              | SPRINTER 3V  | 1984-   |   |   |        |
|              | SPRINTER 50  | 1984-   |   |   |        |
|              | SPRINTER MU. | 1984-   |   |   |        |
|              | STRADA 50    | 1984-   |   |   |        |
|              | STRADA 125   | 1983-   |   |   |        |
|              | ENDURO 50    | 1985-   |   |   | NE-8   |
|              | RAIDER 125   | -   |   |   |        |
|              | TRIAL 50     | 1985-   |   |   |        |
|              | TRIALMATIC50 | 1985-   |   |   |        |
|              | GR.TUR.50 CC | -   |   |   | NE-6   |
|              |              |   |   |   | NE-6P  |
|              | HP1 125      | -   | FI-6I   | FI-6I   |        |
|              |              |   | FI-6IP3   | FI-6IP3   |        |
|              | LEI 50 CC    | -   |   |   | IMS-5  |
|              |              |   |   |   | IMS-5P |
| TRIAL 125    | -            |   |   | NE-8  |        |
| TRIAL 200    | -            |   |   | ZA-1  |        |
|              |              |   |   | ZA-1P   |        |
| GARELLI      | BASIC 50     | 1985-   |   | ZA-1  |        |
|              | BASIC2 50    | 1985-   |   | ZA-1P   |        |
|              | FORMUNO      | 1988-1991   |   |   |        |
|              | GARY         | 1992-   |   |   |        |
|              | GARY DUE 50  | 1988-1991   |   |   |        |
|              | GARY UNO 50  | 1988-1991   |   |   |        |
|              | SAHEL 50 ES  | -1991   |   |   |        |
|              | TEAM 3V 50   | -1991   |   |   |        |
|              | TEAM BIMATIC | -1991   |   |   |        |
|              | TEAM MATIC   | -1991   |   |   |        |
|              | URKA AC-LC50 | -1991   |   |   |        |
|              | VIP N3V 50   | -1991   |   |   |        |
|              | CICLONE 50   | -1986   |   | AF-19   |        |
|              | CICLONE 5V 5 | -1986   |   | AF-19P  |        |
|              | EUREKA FLEX  | -   |   | IMS-5   |        |
|              | JUNIOR T 50  | 1982-1986   |   | IMS-5P  |        |
|              | JUNIOR GT 50 | 1982-1986   |   | ZA-1  |        |
|              | JUNIOR K1005 | -1986   |   | ZA-1P   |        |



# MOTOCICLETA

## MOTORCYCLE

| MARCA BRAND  | MODELO MODEL |  |  |  |
|--------------|--------------|---|---|---|
| GARELLI      | NOI 50       | -1986   |   |   |
|              | VIP 1-N50    | -   |   |   |
|              | VIP 2-N50    | -   |   |   |
|              | VIP 3-N50    | -   |   |   |
|              | VIP 4-N50    | -   |   |   |
|              | CICLONE 5VN  | 1986-1988   | ZA-1  | ZA-1  |
|              | CICLONE LC   | 1986-1988   | ZA-1P   | ZA-1P   |
|              | NOI BIMATIC  | 1987-1991   |   |   |
|              | NOI MATIC    | 1987-1991   |   |   |
|              | NOI TL 50    | 1987-1991   |   |   |
|              | GRAN TURISMO | -   |   | NE-6<br>NE-6P   |
|              | GTA 125      | -   | FI-6I<br>FI-6IP3  | FI-6I<br>FI-6IP3  |
|              | SUPER VIP    | 1985-1989   | AF-6D   | ZA-1  |
|              | TIGER 125XLE | -   |   | ZA-1P   |
|              | TRS 125 S.M. | -   |   |   |
| XR 125 TIGER | -            |   |   |   |
| TIGER XRD    | -            | ZA-1<br>ZA-1P   |   |   |
| GILERA       | 50 GSA LUS   | -   | AF-6D   | NE-8  |
|              | 50 TS-GSA    | -   |   |   |
|              | 50 R1        | -   |   | ZA-2P   |
|              | 50 RALLY     | -   |   |   |
|              | 50 RC TRO.   | -   |   |   |
|              | 50 TREND     | -   |   |   |
|              | 50 SIOUX A   | -   | ZA-4DP  | ZA-4DP  |
|              | 125 APACHE   | 1991-   |   |   |
|              | 125 CROMO    | 1991-   |   |   |
|              | 125 FREE ST  | -   |   |   |
|              | 125 GFR S.P. | -   |   |   |
|              | 125 SIOUX    | -   |   |   |
|              | 350 NORDWES  | 1993-   |   |   |
|              | 600 NORD WE  | -   |   |   |
|              | 600 R        | 1993-   |   |   |
|              | 600 RC       | 1991-   |   |   |
|              | RC 750 R     | -   |   |   |
|              | TYPHOON      | -1995   |   |   |
|              | 125 CX AE    | -   | ZA-1  | ZA-1  |
|              | 125 GRF      | 1993-   | ZA-1P   | ZA-1P   |
|              | 125 R        | 1993-   |   |   |
|              | 503 AE       | 1993-   |   |   |
|              | ARIZONA 125  | -   |   |   |
|              | ARIZONA 250  | -   |   |   |
|              | BULLIT AE    | 1992  |   |   |
|              | BULLIT KICK  | 1992  |   |   |
|              | BULLIT MIX   | 1993-   |   |   |
|              | RC 600 R     | 1991-   |   |   |
|              | RTX 125-200  | -   |   |   |
|              | RV 125-200   | -   |   |   |
| RX 125-200   | -            |   |   |   |
| SIOUX AE     | 1993-        |   |   |   |
| 125 GR1-TG1  | -            |   | NE-6  |   |
| 150          | -            |   | NE-6P   |   |



| MARCA BRAND     | MODELO MODEL |  |  |  |
|-----------------|--------------|---|---|---|
| GILERA          | ECO 50       | -   |   |   |
|                 | 125 MRX      | -1991   | FI-1  | FI-1  |
|                 | 125 RC       | -1991   | FI-1P   | FI-1P   |
|                 | 125 SPO1     | -1991   |   |   |
|                 | 125 SPO2     | -1991   |   |   |
|                 | 125 XR2 R.   | -1991   |   |   |
|                 | 125 TG2      | -   | AF-6D   | ZA-1<br>ZA-1P   |
|                 | 200 T 4      | -   | AF-9D   |   |
|                 | 200 T45      | -   | AF-9DP  |   |
|                 | CUSTOM 125   | -   | AF-9I   |   |
|                 | CUSTOM 200   | -   | AF-9IP  | FEM-1D<br>FEM-1I  |
|                 | 250 NGR      | -   | FI-6I<br>FI-6IP3  | FI-6I<br>FI-6IP3  |
|                 | 350 DAKOTA   | -1990   | FI-6I   | FI-6I   |
|                 | 500 DAKOTA   | -1990   | FI-6IP3   | FI-6IP3   |
|                 | 500 SATURNO  | -1990   | ZA-2P   | ZA-2P   |
|                 | 600 RC       | -1990   |   |   |
|                 | CBA 50       | -1991   |   | ZA-1<br>ZA-1P   |
|                 | NCR 50       | 2006-   | ZA-9P1  | ZA-9P1  |
|                 | NEXUS        | 2006-   |   |   |
|                 | RUNNER       | 2006-   |   |   |
| STORM 50        | 1995         | ZA-7DP  |   |   |
| TYPHOON         | 1995-        |   |   |   |
| HARLEY DAVIDSON | 883 SPORT.   | 1994  | HD-4D   | HD-4D   |
|                 | 1200 SPORT.  | 1994  |   |   |
|                 | FLH 1340 EL  | -   | HD-1  | NE-6  |
|                 | FLHC 1340 EL | -   | HD-1D   | NE-6P   |
|                 | FLHC 1340 S. | -   | HD-2  | NE-8  |
|                 | FLT 1340 TO. | -   | HD-2D   |   |
|                 | FLTC 1340 TO | -   | HD-3  |   |
|                 | FXB 1340 ST. | -   | HD-3D   |   |
|                 | FXE 1340 SU. | -   |   |   |
|                 | FXPS 1340 SU | -   |   |   |
|                 | FXR 1340 SU. | -   |   |   |
|                 | FXS 1340 LOW | -   |   |   |
|                 | FXWG 1340 WI | -   |   |   |
|                 | XLH 1000 SP  | -   |   |   |
|                 | XLS 1000 RO  | -   |   |   |
| VARIOS          | -1960        | BS-6  |   |   |
| VARIOS          | 1996         | CHI-1T  | CHI-1T  |   |
| HERCULES        | K 125        | -   | YAMA-21I  | YAMA-21IP   |
|                 |              |   |   |   |
| HM              | LOCUSTA      | -   | ZA-9P1  |   |
| HONDA           | 125          | 1980-   | SUZU-13P  | NE-6  |
|                 | 125 E        | 1980-1982   | SUZU-4I   | NE-6P   |
|                 | 125 S        | 1980-   | SUZU-4IP  |   |
|                 | 125 SILHO.   | 1980-   |   |   |
|                 | CB 125 T2    | 1982-   |   |   |



| MARCA BRAND  | MODELO MODEL |  |  |  |  |
|--------------|--------------|---|---|---|--|
| HONDA        | 125 E        | 1982-   | SUZU-13P<br>SUZU-4I<br>SUZU-4IP   | NE-8  |  |
|              | 125 LEAD     | 1991  | HOND-4I   | HOND-4I   |  |
|              | 600 VT.R.    | 1990-   | HOND-4IP1   | HOND-4IP1   |  |
|              | CBR 600 F    | 1987-   |   |   |  |
|              | CBR 1000     | 1991-1992   |   |   |  |
|              | VF 750 C     | 1990-   |   |   |  |
|              | VFR 750 FK   | 1990-1991   |   |   |  |
|              | VFR 750 FL   | 1990-1991   |   |   |  |
|              | VFR 750 P.   | 1990-1991   |   |   |  |
|              | VFR 750 R    | 1990-1991   |   |   |  |
|              | XRV 750 A.   | 1992-   |   |   |  |
|              | 125 VISION   | -   | SUZU-13DP<br>SUZU-4D<br>SUZU-4DP  | SUZU-13DP<br>SUZU-4D<br>SUZU-4DP  |  |
|              | 200 R        | -1989   | HOND-19   | HOND-19   |  |
|              | CB 650       | 1984-   | HOND-19D  | HOND-19D  |  |
|              | CB 750       | 1986-1991   | HOND-19DP   | HOND-19DP   |  |
|              | CB 900       | 1984-   | HOND-19P  | HOND-19P  |  |
|              | CB 1100      | -1993   | HOND-4D   | HOND-4D   |  |
|              | CBX 500      | 1984-1987   | HOND-4DP  | HOND-4DP  |  |
|              | CBX 550      | 1984  | HOND-4DP2   | HOND-4DP2   |  |
|              | CBX 650      | 1984-   | HOND-4I   | HOND-4I   |  |
|              | CBX 750      | 1986-1991   | HOND-4IP  | HOND-4IP  |  |
|              | CR 500       | 1984-1987   |   |   |  |
|              | CX 650       | 1984-   |   |   |  |
|              | FT 500       | 1984-1987   |   |   |  |
|              | GL 650       | 1984-   |   |   |  |
|              | GL 1100      | -1991   |   |   |  |
|              | NS 400       | 1986-   |   |   |  |
|              | VF 500       | 1984-1987   |   |   |  |
|              | VF 750       | 1986-1991   |   |   |  |
|              | VF 1000      | -1991   |   |   |  |
|              | VF 1100      | -1991   |   |   |  |
|              | VRF 750      | 1986-1991   |   |   |  |
|              | VT 500       | 1984-1987   |   |   |  |
|              | XLV 750      | 1986-1991   |   |   |  |
|              | YT 1100      | -1991   |   |   |  |
|              | 350 FOUR     | 1979-1981   | HOND-7I   | NE-6  |  |
|              | 500 FOUR     | 1979-   |   | NE-6P   |  |
|              | 350 FOUR     | 1981-   | HOND-4D   | NE-6  |  |
|              | 400 FOUR     | 1981-1982   | HOND-4DP  | NE-6P   |  |
|              | CB 400 N     | 1979-1981   | HOND-4DP2   |   |  |
|              | CB 400 N     | 1981-1982   |   |   |  |
|              | CB 750 K     | 1980-   |   |   |  |
| CM 400 T     | 1981-1982    |   |   |   |  |
| CX 500       | 1981-1982    |   |   |   |  |
| 400 CBF      | 1979-        | HOND-3I   | NE-6  |   |  |
| 500 CBT      | -            |   | NE-6P   |   |  |
| 500 FOUR     | 1976-1979    | HOND-49   | NE-6<br>NE-6P   |   |  |
| 500 FOUR K   | 1979-        | HOND-4D   |   |   |  |
| 1100 GOLD W. | -            | HOND-4DP  |   |   |  |



| MARCA BRAND  | MODELO MODEL |  |  |  |
|--------------|--------------|---|---|---|
| HONDA        | CB 650       | -   | HOND-4DP2   |   |
|              | CB 750 F.    | 1980-   |   |   |
|              | CB 750 FI    | 1981-   |   |   |
|              | CX 500       | 1979-1981   |   |   |
|              | 500 R        | 1983-   | VO-VBP1   | VO-VBP1   |
|              | 600 R        | 1983-   |   |   |
|              | 1200 G.W.    | -1991   |   |   |
|              | GL 1200      | -1991   |   |   |
|              | GL 1500      | -1991   |   |   |
|              | GX 1200 DL   | -1991   |   |   |
|              | VF 750 C     | 1982-1990   |   |   |
|              | VF 750 CU.   | 1982-   |   |   |
|              | VF 750 S     | 1982-   |   |   |
|              | XL 350 R     | 1986-1991   |   |   |
|              | XL 350 RF    | 1986-1991   |   |   |
|              | 500 R CROSS  | 1982-   | HOND-4D   | NE-8  |
|              | CB 250 N     | 1986-   | HOND-4DP  |   |
|              | CB 250 RS    | 1986-   | HOND-4DP2   |   |
|              | CB 750 C     | 1979-   |   |   |
|              | CB 750 K     | 1979-1980   |   |   |
|              | CB 900 B.    | 1982-   |   |   |
|              | CB 900 F     | 1982-   |   |   |
|              | CB 900 FI    | 1982-   |   |   |
|              | CB 1100 R    | -   |   |   |
|              | CBR 250 F    | 1986-   |   |   |
|              | CBX 400 F    | 1982-   |   |   |
|              | CBX 400 FC   | 1984-   |   |   |
|              | CBX 400 FI   | 1984-   |   |   |
|              | CDI 125 6    | 1984-1986   |   |   |
|              | FT 500       | 1983-1984   |   |   |
|              | RAVEL 250    | 1986-   |   |   |
|              | REBEL 250    | 1986-   |   |   |
|              | XL 500 R     | 1982-1984   |   |   |
|              | XL 500 S     | 1982-   |   |   |
| XR 500 R     | 1982-1984    |   |   |   |
| 600 PROA.    | 1985-1991    | HOND-4D   | HOND-4D   |   |
| 600 VTR.     | 1985-1991    | HOND-4DP  | HOND-4DP  |   |
| CB 450       | 1986-        | HOND-4DP2   | HOND-4DP2   |   |
| CBX 1000 S.S | -            | HOND-4I   | HOND-4I   |   |
| CX 500       | 1984         | HOND-4IP  | HOND-4IP  |   |
| MTX 200 R    | -1989        |   |   |   |
| NTV 650      | 1984-1992    |   |   |   |
| ST 1100      | -1991        |   |   |   |
| TRX 200 SX   | -1989        |   |   |   |
| VF 400 F     | 1986-        |   |   |   |
| VFR 400 R    | 1986-        |   |   |   |
| XL 200       | -1989        |   |   |   |
| XL 200 PD    | -1989        |   |   |   |
| XL 500 R     | 1984-        |   |   |   |
| XL 600       | -1984        |   |   |   |
| XL 600       | 1985-1991    |   |   |   |
| XL 600 LM    | 1985-1991    |   |   |   |
| XL 600 R     | 1985-1991    |   |   |   |
| XL 600 RM    | 1985-1991    |   |   |   |



# MOTOCICLETA

## MOTORCYCLE

| MARCA BRAND | MODELO MODEL |  |  |  |
|-------------|--------------|---|---|---|
| HONDA       | XL 600 RX    | 1985-1991   |   |   |
|             | XR 500 R     | 1984-   |   |   |
|             | 600 V.T.     | 1992-   | HOND-4D   | HOND-4D   |
|             | CB 750       | 1992-   | HOND-4DP1   | HOND-4DP1   |
|             | NTV 650      | 1992-1996   | HOND-4DP2   | HOND-4DP2   |
|             | NX 650 D     | 1983-   |   |   |
|             | VFR 750      | 1986-1989   |   |   |
|             | VT 600       | 1989-   |   |   |
|             | 650 G.W.     | 1983-1991   | HOND-4D   | HOND-4D   |
|             | ASPENCADE    | -1991   | HOND-4DP  | HOND-4DP  |
|             | CB 250 N     | 1982-1985   | HOND-4DP2   | HOND-4DP2   |
|             | CB 250 RS    | 1982-1985   |   |   |
|             | CB 400 L     | 1985-   |   |   |
|             | CB 400 N     | 1982-   |   |   |
|             | CB 550       | 1982-   |   |   |
|             | CBR 1000     | -1991   |   |   |
|             | CBX 125      | 1984-   | HOND-4DP1   | HOND-4DP1   |
|             | CBX 1100 6C. | -   | HOND-4DP2   | HOND-4DP2   |
|             | CL 250 N     | 1982-1985   | HOND-4D   |   |
|             | CL 250 S     | 1982-1985   | HOND-4DP  |   |
|             | CM 250 C     | 1982-1985   | HOND-4DP2   |   |
|             | CX 500       | 1982-1984   | HOND-4I   |   |
|             | ENTERSTAT    | -1991   | HOND-4IP  |   |
|             | G.WING 1.2   | -1991   | HOND-4I   | HOND-4I   |
|             | GL 500       | 1982-   | HOND-4IP  | HOND-4IP  |
|             | ST 1100 PE   | 1991-   |   |   |
|             | VT 500       | 1983-1984   |   |   |
|             | X 400 R      | 1986-   |   |   |
|             | XL 125 P.D   | 1984-1986   |   |   |
|             | XL 125 P3    | 1990-   |   |   |
|             | XL 125 PD    | 1984-1986   |   |   |
|             | XL 125 R     | 1984-1986   |   |   |
|             | XL 125 R3    | 1990-   |   |   |
|             | XL 125 SD    | 1984-1986   |   |   |
|             | XL 200 P3    | 1989-1991   |   |   |
|             | XL 200 PD    | 1989-1991   |   |   |
|             | XL 200 R     | 1989-1991   |   |   |
|             | XL 200 R2    | 1989-1991   |   |   |
|             | 750 AFRICA   | 1991  | HOND-19   | HOND-19   |
|             |              |   | HOND-19D  | HOND-19D  |
|             |              |   | HOND-19DP   | HOND-19DP   |
|             |              |   | HOND-19P  | HOND-19P  |
|             |              |   | HOND-4D   | HOND-4D   |
|             |              |   | HOND-4DP1   | HOND-4DP1   |
|             |              |   | HOND-4DP2   | HOND-4DP2   |
| 750 FOUR    | 1979-        | HOND-4D   |   |   |
|             |              | HOND-4DP  |   |   |
|             |              | HOND-4DP2   |   |   |
|             |              | HOND-4I   |   |   |
|             |              | HOND-4IP  |   |   |
| 750 RXLV    | 1985-        | HOND-4I   | HOND-4I   |   |
| 750 XLV     | 1985-        | HOND-4IP  | HOND-4IP  |   |
| CB 125 T    | 1986-        |   |   |   |
| CN 250      | -1991        |   |   |   |

| MARCA BRAND  | MODELO MODEL |  |  |  |
|--------------|--------------|---|---|---|
| HONDA        | MTX 125 R    | 1986-   |   |   |
|              | NX 125       | 1990-   |   |   |
|              | NXR 650 A.   | 1988-1990   |   |   |
|              | PC 800       | 1989-1991   |   |   |
|              | SPACY SCOOT. | -   |   |   |
|              | XL 250 R     | -1991   |   |   |
|              | BIG RED 125  | 1986-   | HOND-19   | HOND-19   |
|              | CB 450       | 1986  | HOND-19D  | HOND-19D  |
|              | CBR 1000     | 1992  | HOND-19DP   | HOND-19DP   |
|              | CN 250       | 1991-1994   | HOND-19P  | HOND-19P  |
|              | CRM 125      | 1990-1992   | HOND-4I   | NE-6  |
|              | CX 500       | 1984-1987   | HOND-4IP  | NE-6P   |
|              | MTX 200      | -1989   |   | NE-8  |
|              | NH 125 PEAD  | 1986-   | HOND-4I   | NE-6  |
|              | NTV 650      | 1984-1994   | HOND-4IP  | NE-6P   |
|              | NX 650       | 1991-1994   |   |   |
|              | PK 50 DX WA. | 1992  | HOND-4D   | HOND-4D   |
|              | SA 50 M VIS. | 1992  | HOND-4DP1   | HOND-4DP1   |
|              | SPACY        | -   | HOND-4DP2   | HOND-4DP2   |
|              | ST 1100      | 1992  | HOND-4I   | HOND-4I   |
|              | TRX 200      | -1989   | HOND-4IP1   | HOND-4IP1   |
|              | VF 400       | 1986  |   |   |
|              | VFR 400      | 1986  |   |   |
|              | VFR 750      | 1991  |   |   |
|              | XL 125       | 1984-1986   | HOND-24P  | HOND-24P  |
|              | XL 125       | 1990-   |   |   |
|              | XL 200       | 1990-1991   |   |   |
|              | XL 250       | -1991   |   |   |
|              | XL 500       | 1984-   |   |   |
|              | XL 600       | 1984-1985   |   |   |
|              | XR 500       | 1984-   |   |   |
|              | CAMINO S 50  | -   |   | NE-8  |
|              | CBX 900 FII  | -   |   |   |
|              | CB 125 S     | 1979-   | HOND-4D   | NE-6  |
|              |              |   | HOND-4DP  | NE-6P   |
|              |              |   | HOND-4DP2   |   |
|              |              |   | HOND-4I   |   |
|              |              |   | HOND-4IP  |   |
|              | CB 125 SI.   | 1982-   | HOND-4I   | NE-6  |
|              | XL 125       | 1982-1983   | HOND-4IP  | NE-6P   |
|              |              |   |   | NE-8  |
|              | CB 125 X     | 1982-   | HOND-4I   | NE-6  |
|              | CBX 125      | 1982-1983   | HOND-4IP  | NE-6P   |
|              | CS 125       | 1982-   |   |   |
|              | CB 500       | 1994-1997   | HOND-4D   | HOND-4D   |
| CB 1000      | 1993-        | HOND-4DP1   | HOND-4DP1   |   |
| CBR 900 RR   | 1994-1996    | HOND-4DP2   | HOND-4DP2   |   |
| CBR 1000     | 1992-        | HOND-4I   | HOND-4I   |   |
| CRM 125      | 1990         | HOND-4IP1   | HOND-4IP1   |   |
| NSR 125 F    | 1990-        |   |   |   |
| NSR 125 R    | 1990-        |   |   |   |
| NSR 125 R SP | 1990-        |   |   |   |
| CB 500S      | 1997-        | HOND-24P  | HOND-24P  |   |
| CBF 500      | 2004-        |   |   |   |



| MARCA BRAND  | MODELO MODEL |  |  |  |       |
|--------------|--------------|---|---|---|-------|
| HONDA        | CBF 600      | 2004-   |   |   |       |
|              | CBR 900 RR   | 1997  |   |   |       |
|              | CBR 1000 F   | 1997  |   |   |       |
|              | FORZA        | 2005-   |   |   |       |
|              | NTV 650      | 1997-1998   |   |   |       |
|              | NX 650       | 1997-   |   |   |       |
|              | SFX 50       | 1997-   |   |   |       |
|              | SH 50        | 1997-   |   |   |       |
|              | SH 100       | 1997-   |   |   |       |
|              | SJ 100 BALI  | 1997-   |   |   |       |
|              | ST 1100      | 1997-   |   |   |       |
|              | CB 550 F     | 1979-1982   |   | NE-6  | NE-6P |
|              | CB 650 CUST  | -   | HOND-4D   | NE-8  |       |
|              | CB 650 SC    | -   | HOND-4DP1   |   |       |
|              |              |   | HOND-4DP2   |   |       |
|              | CB 750 F     | 1979-   | HOND-7D   | NE-6  |       |
|              |              |   | HOND-7I   | NE-6P   |       |
|              | CB 750 FO.   | 1978-   | HOND-7I   |   |       |
|              | CBX 125      | 1983-1984   | SUZU-13P  | NE-6  |       |
|              | MH 125       | 1983-   | SUZU-4I   | NE-6P   |       |
|              | XL 125       | 1983-1984   | SUZU-4IP  | NE-8  |       |
|              | CBX 900      | 1984-   | HOND-19   |   |       |
|              |              |   | HOND-19D  |   |       |
|              |              |   | HOND-19DP   |   |       |
|              |              |   | HOND-19P  |   |       |
|              | CG 125       | 1993-2008   | HOND-26DP1  | HOND-26DP1  |       |
|              | ECONO POW.90 | 1993-   | HOND-26P1   | HOND-26P1   |       |
|              | CMX 450 SC.  | -1991   | SUZU-13P  | SUZU-13P  |       |
|              |              |   | SUZU-4I   | SUZU-4I   |       |
|              |              |   | SUZU-4IP  | SUZU-4IP  |       |
|              | CR 250       | -1991   | HOND-19   | HOND-19   |       |
|              |              |   | HOND-19D  | HOND-19D  |       |
|              |              | HOND-19DP   | HOND-19DP   |   |       |
|              |              | HOND-19P  | HOND-19P  |   |       |
|              |              | HOND-4I   | HOND-4I   |   |       |
|              |              | HOND-4IP  | HOND-4IP  |   |       |
| DYLAN 125    | 2004-        | ZA-9P1  | ZA-9P1  |   |       |
| PHANTEON 150 | 2003-        |   |   |   |       |
| PS 125I      | 2006-        |   |   |   |       |
| PS 150I      | 2006-        |   |   |   |       |
| SH 125I      | 2005-        |   |   |   |       |
| SH 150I      | 2006-        |   |   |   |       |
| HORNET       | 1998         | HOND-43   | HOND-43   |   |       |
|              |              | HOND-43D  | HOND-43D  |   |       |
|              |              | HOND-43DP   | HOND-43DP   |   |       |
|              |              | HOND-43P  | HOND-43P  |   |       |
| LEAD 100     | 2003-        | HOND-28P  |   |   |       |
| MTX 125      | 1990-1992    | HOND-19   | HOND-19   |   |       |
| MX 125       | 1990-1992    | HOND-19D  | HOND-19D  |   |       |
|              |              | HOND-19DP   | HOND-19DP   |   |       |
|              |              | HOND-19P  | HOND-19P  |   |       |
|              |              | HOND-4D   | HOND-4D   |   |       |
|              |              | HOND-4DP1   | HOND-4DP1   |   |       |



| MARCA BRAND | MODELO MODEL |  |  |  |
|-------------|--------------|---|---|---|
| HONDA       |              |   | HOND-4DP2   | HOND-4DP2   |
|             |              |   | HOND-4I   | HOND-4I   |
|             |              |   | HOND-4IP1   | HOND-4IP1   |
|             | NH 50        | -1991   | AF-6D   | NE-8  |
|             | PA 50 DLX    | -1991   |   |   |
|             | PK 50 DX     | -1991   |   |   |
|             | PX 50 S      | -1991   |   |   |
|             | SA 50        | -1991   |   |   |
|             | PK 50        | 1993-   | HOND-25P2   | HOND-25P2   |
|             | SA 50 P      | 1993-   | HOND-4I   | HOND-4I   |
|             | SH 50        | 1993-1996   | HOND-4IP1   | HOND-4IP1   |
|             | SFX 50       | 1994-1995   | HOND-20   |   |
|             | SJ 50 BALI   | 1994-1995   | HOND-20D  |   |
|             |              |   | HOND-20DP   |   |
|             |              |   | HOND-20P  |   |
|             | SH 50        | 1991-1993   | VO-VBP1   | HOND-30DP2  |
|             |              |   |   | HOND-30P2   |
|             |              |   |   | VO-VBP1   |
|             | VFR 750      | 1989-1991   | HOND-20   | HOND-20   |
|             |              |   | HOND-20D  | HOND-20D  |
|             |              | HOND-20DP   | HOND-20DP   |   |
|             |              | HOND-20P  | HOND-20P  |   |
| VRF 750     | 1989-1991    | HOND-28DP   | HOND-28DP   |   |
|             |              | HOND-28P  | HOND-28P  |   |
| ITALJET     | ASCOT        | 1992-   | YAMA-27   | YAMA-27   |
|             | BAZOOKA      | 1992-   | YAMA-27D  | YAMA-27D  |
|             | TIFFANY      | 1992-   | YAMA-27DP   | YAMA-27DP   |
|             |              |   | YAMA-27P  | YAMA-27P  |
|             | DRAGSTER     | 1998  | ZA-9P   | ZA-9P   |
|             | FORMULA 50   | 1996-   | ZA-4DP  |   |
|             | PISTA        | 1994  | YAMA-27DP   | YAMA-27DP   |
|             | SCOOP        | 1994  | YAMA-27P  | YAMA-27P  |
| KAWASAKI    | 400 CUSTOM   | 1991-   | KAW-6P  | KAW-6P  |
|             | 750 CUSTOM   | 1991-   |   |   |
|             | EN 500       | 1993-   |   |   |
|             | KLX 650      | -   |   |   |
|             | TWIN CAM     | 1992  |   |   |
|             | VN 1500 SUMO | -   |   |   |
|             | VN 1600      | 2003-   |   |   |
|             | ZXR 400      | 1991-   |   |   |
|             | ZXR 1100     | 1991-   |   |   |
|             | ZZR 250      | -   |   |   |
|             | ZZR 600      | -   |   |   |
|             | ZZR 1100     | 1991-1992   |   |   |
|             | 400 GT       | 1980-1985   | KAW-8   | KAW-8   |
|             | 400 KZ       | 1980-1985   |   |   |
|             | 400 Z        | 1980-1985   |   |   |
|             | 400 ZB       | 1980-1985   |   |   |
|             | 550 LTD      | 1982-   | KAW-3   | KAW-3   |
|             | GPZ 250      | -   |   |   |
|             | GPZ 305      | -   |   |   |
|             | GPZ 450      | -   |   |   |
|             | GPZ 550      | 1982-1984   |   |   |
|             | GPZ 600 R    | -   |   |   |









# MOTOCICLETA

## MOTORCYCLE

| MARCA BRAND | MODELO MODEL |  |  |  |
|-------------|--------------|---|---|---|
| KAWASAKI    | GPZ 750      | -   |   |   |
|             | GPZ 750 R    | -   |   |   |
|             | GPZ 900 R    | -   |   |   |
|             | GPZ 1000     | -   |   |   |
|             | GPZ 1100     | -   |   |   |
|             | GPZ 1300     | -   |   |   |
|             | KL 250       | -   |   |   |
|             | KLR 250      | -   |   |   |
|             | VOYAGER      | -   |   |   |
|             | Z 250 C      | -   |   |   |
|             | Z 250 GP     | -   |   |   |
|             | Z 250 LTD    | -   |   |   |
|             | Z 305        | -   |   |   |
|             | Z 450        | -   |   |   |
|             | Z 550        | 1982-1984   |   |   |
|             | Z 600        | -   |   |   |
|             | Z 750        | -   |   |   |
|             | Z 750 LTD    | -   |   |   |
|             | Z 750 TURBO  | -   |   |   |
|             | Z 900        | -   |   |   |
|             | Z 1000       | -   |   |   |
|             | Z 1100       | -   |   |   |
|             | Z 1300       | -   |   |   |
|             | 900 Z1       | -   | KAW-4   | KAW-4   |
|             | 1000 GTR     | 1984-1991   | KAW-3   | KAW-5   |
|             | 1300 Z       | 1986-1991   | KAW-5   | KAW-5P  |
|             | CS 250       | 1984-1986   | KAW-5P  |   |
|             | FX 400 R     | 1984-   |   |   |
|             | GPZ 305      | 1984-   |   |   |
|             | GPZ 550      | 1984-1990   |   |   |
|             | GPZ 750      | 1984-1991   |   |   |
|             | GPZ 900 R    | -1986   |   |   |
|             | GPZ 1000     | 1984-1991   |   |   |
|             | GPZ 1100     | 1984-   |   |   |
|             | GT 750       | 1984-1991   |   |   |
|             | GTR 1000     | 1984-1991   |   |   |
|             | KL 250       | 1984-1986   |   |   |
|             | KLR 570      | 1984-1990   |   |   |
|             | KLR 650      | 1980-1991   |   |   |
|             | LTD 450      | 1984-   |   |   |
|             | SR 650       | 1980-1991   |   |   |
|             | TENGAJ 650   | 1980-1991   | KAW-5   | KAW-5   |
|             | VN 750 T.    | 1984-1991   | KAW-5P  | KAW-5P  |
|             | Z 250        | 1984-   |   |   |
|             | Z 305 B.     | 1984-   |   |   |
|             | Z 400        | 1984-   |   |   |
|             | Z 440        | 1984-   |   |   |
|             | Z 550        | 1984-1990   |   |   |
|             | Z 750        | 1985-1992   |   |   |
|             | Z 1000 RZ    | 1984-1991   |   |   |
| Z 1100      | 1984-        |   |   |   |
| Z 1300      | 1986-1991    |   |   |   |
| ZN 1300 V   | 1986-1991    |   |   |   |
| ZR 550      | 1984-1990    |   |   |   |



| MARCA BRAND | MODELO MODEL |  |  |  |
|-------------|--------------|---|---|---|
| KAWASAKI    | ZX 550       | 1984-1990   |   |   |
|             | ZX 1000      | 1984-1991   |   |   |
|             | ZXR 750      | 1985-1992   |   |   |
|             | AR 125       | -1986   |   | NE-6  |
|             | KDX 175      | -   |   | NE-6P   |
|             | KE 125       | -1986   |   |   |
|             | KE 175       | -   |   |   |
|             | KMX 125      | -1986   |   |   |
|             | KX 125       | -1986   |   |   |
|             | EJ 650       | 1999-2006   |   |   |
|             | EJ 800       | 2011  |   |   |
|             | KLR 250      | 1997-2010   |   |   |
|             | KLX 125      | 2010-2011   |   |   |
|             | KLX 250      | 1999  |   |   |
|             | NINJA 250R   | 1990-2007   |   |   |
|             | NINJA 500R   | 1993-1994   |   |   |
|             | NINJA 600R   | 1990-1996   |   |   |
|             | NINJA ZX- 6R | 1993-2006   |   |   |
|             | NINJA ZX-11R | 1993-2001   |   |   |
|             | VN 250       | 2000  |   |   |
|             | VN 400       | 1999-2000   |   |   |
|             | VN 1500      | 1987-2001   |   |   |
|             | VN 1700      | 2009  |   |   |
|             | VN 2000      | 2004-2010   |   |   |
|             | Z 500        | 1991-1998   |   |   |
|             | Z 750        | 1992-1997   |   |   |
|             | Z 1000       | 2003-2005   |   |   |
|             | ZG 1000 CON. | 1992-2006   |   |   |
|             | ZRX 1100     | 1992-2000   |   |   |
|             | ZRX 1100     | 2001-2006   |   |   |
|             | ZRX 1200     | 2001-2006   |   |   |
|             | EN 500       | -1991   | KAW-2I  | KAW-2I  |
|             | KLR 250      | 1985-1986   |   |   |
|             | ER 5         | 2003-   | KAW-9P  | KAW-9P  |
|             | NINJA ZX- 6R | 2003-   |   |   |
|             | NINJA ZX- 7R | 2003-   |   |   |
|             | NINJA ZX- 9R | 2003-   |   |   |
|             | NINJA ZX-12R | 2003-   |   |   |
|             | Z 750        | 2004-   |   |   |
|             | ZR 7         | 1999-   |   |   |
| ZZR 1200    | 2003-        |   |   |   |
| GLX 1100    | 1993-        | KAW-5   | KAW-5   |   |
| GPX 600     | 1986-1990    | KAW-5P  | KAW-5P  |   |
| GPZ 500     | 1987-        |   |   |   |
| GPZ 500 S   | 1994         |   |   |   |
| GPZ 600     | 1986-1990    |   |   |   |
| KDX 250 D   | -            |   |   |   |
| KL 250      | 1986-        |   |   |   |
| KLE 500     | 1994         |   |   |   |
| KLR 250     | 1986-1996    |   |   |   |
| KX 250      | 1986-        |   |   |   |
| LTD 450 C.  | 1986-        |   |   |   |
| SJ 50 BALI  | 1994         |   |   |   |
| Z 650       | 1983         |   |   |   |



| MARCA BRAND | MODELO MODEL |  |  |  |
|-------------|--------------|---|---|---|
| KAWASAKI    | ZL 600       | 1990-1992   |   |   |
|             | ZZR 600      | 1990-1992   |   |   |
|             | GPZ 400      | -   | KAW-3   | KAW-3   |
|             | GPZ 550      | -   | KAW-4   | KAW-4   |
|             | LTD 450      | -   | SUZU-13P  |   |
|             | Z 400        | -   | SUZU-4I   |   |
|             | Z 400 TW.    | -   | SUZU-4IP  |   |
|             | Z 440 LTD    | -   |   |   |
|             | Z 550 LTD    | -   |   |   |
|             | GPZ 750      | -1984   | KAW-3   |   |
|             | Z 400 F      | 1981-1982   |   |   |
|             | Z 400 J      | 1981-1982   |   |   |
|             | Z 500        | 1981-1991   |   |   |
|             | Z 750        | 1984-1985   |   |   |
|             | KH 400       | 1978-   | KAW-4   |   |
|             | OH 400       | 1978-   | SUZU-13DP   |   |
|             | Z 400        | 1978-1981   | SUZU-13P  |   |
|             |              |   | SUZU-4D   |   |
|             |              |   | SUZU-4DP  |   |
|             |              |   | SUZU-4I   |   |
|             |              |   | SUZU-4IP  |   |
|             | KL 600 S     | 1986-1991   | KAW-2D  | KAW-2D  |
|             | KLR 600      | 1986-1991   | KAW-2I  | KAW-2I  |
|             | KLR 600      | -   | KAW-1D  | KAW-1D  |
|             | Z 440        | -   | KAW-1I  | KAW-1I  |
|             | Z 650 F      | 1984-1991   |   |   |
|             | Z 650 S      | 1984-1991   |   |   |
|             | Z 650 SR     | 1984-1991   |   |   |
|             | KLR 600 S    | 1994-1995   | KAW-7P  | KAW-7P  |
|             | KLR 650      | 1994-1995   |   |   |
|             | NINJA ZX- 9R | 1994-1995   |   |   |
|             | ZXR 750      | 1993-1994   |   |   |
|             | ZZR 600      | 1994-1995   |   |   |
|             | ZZR 1100     | 1993-1994   |   |   |
|             | KL 1000      | 2004-   | SUZU-12DP   | SUZU-12DP   |
|             | LDT 500      | 1995  | KAW-6DP   | KAW-6DP   |
|             | VN 800       | 1995  |   |   |
|             | NINJA 250R   | 2011  | KAW-10P   | KAW-10P   |
|             | Z 250 A      | 1982-   | KAW-2I  |   |
|             | Z 250 C      | 1982-   | KAW-8   |   |
|             | Z 250 J      | 1982-   | KAW-8D  |   |
|             | Z 400        | 1978-1980   | KAW-8   |   |
| Z 400       | 1981         |   |   |   |
| Z 400       | 1981-1984    | KAW-2I  |   |   |
| Z 440 H     | 1982-        | KAW-2D  |   |   |
| Z 440 J     | 1982-        | KAW-2I  |   |   |
| Z 440 LTD   | 1982-        |   |   |   |
| ZL 600 ELI. | 1997         | KAW-5   |   |   |
|             |              | KAW-5P  |   |   |
| ZXR 400     | 1990-1991    | KAW-2D  | KAW-2D  |   |
| ZXR 1100    | 1990-1991    |   |   |   |
| ZZR 1100    | 1990-1991    |   |   |   |
| KTM         | ER 5         | 2003-   | ZA-9P1  | ZA-9P1  |
|             | MODELOS      | 1988-   | VO-VBP1   | VO-VBP1   |



| MARCA BRAND   | MODELO MODEL |  |  |  |        |
|---------------|--------------|---|---|---|--------|
| KYMCO         | GRANDINK     | 2001  |   |   |        |
|               | CX 50        | 1997  | HOND-4I   | HOND-4I   |        |
|               | K 1250       | 1997  | HOND-4IP  | HOND-4IP  |        |
|               | KB 50        | 1997  |   |   |        |
|               | SNIPER 50 DD | 1997  |   |   |        |
|               | HEROISM      | 1997-   | KYM-1DP   | KYM-1DP   |        |
|               |              |   | KYM-1P  | KYM-1P  |        |
|               | LAMBRETTA    | LUI 50  | -   |   | IMS-3  |
|               |              |   |   |   | IMS-3P |
|               |              |   |   |   | NE-56  |
| LAVERDA       | 50 ATLAS     | 1986-1990   | ZA-1  | ZA-1  |        |
|               | 50 GAUCHO    | 1986-   | ZA-1P   | ZA-1P   |        |
|               | 125 CU RIDE  | 1986-1990   |   |   |        |
|               | 125 FORMULA  | 1986-1990   |   |   |        |
|               | 125 GS LES.  | 1984-   |   |   |        |
|               | 125 L ELEG.  | 1984-   |   |   |        |
|               | 125 LB CUS.  | 1984-   |   |   |        |
|               | 125 LB SAB.  | 1984-   |   |   |        |
|               | 125 LB UNO   | 1984-   |   |   |        |
|               | 125 LESMO G  | 1986-1990   |   |   |        |
|               | 125 LZ CUS.  | 1984-   |   |   |        |
|               | 350 LESMO    | 1984-   |   |   |        |
|               | 600 ATLAS O  | -   |   |   |        |
|               | 1000 SFC     | 1986-   |   |   |        |
|               | V6 1000 R    | -   |   |   |        |
|               | 50 LZ        | -   | NE-8  | NE-8  |        |
|               | 125 LZ       | 1978-   | NE-6  | NE-6  |        |
|               | 125 LZ C.    | 1978-   | NE-6P   | NE-6P   |        |
|               | 125 LZ S.    | 1978-   | NE-8  |   |        |
|               | 500 4T       | -   | SUZU-13P  | NE-6  |        |
|               | 500 SFC      | -   | SUZU-4I   | NE-6P   |        |
|               | 750          | 1978-   | SUZU-4IP  |   |        |
| 1000          | 1978-        |   |   |   |        |
| 1000 JOTA     | -            |   |   |   |        |
| 1000 JOTA 120 | -            |   |   |   |        |
| 1000 RGS      | -            |   |   |   |        |
| 1200          | 1978-        |   |   |   |        |
| 1200 TS       | 1978-        |   |   |   |        |
| PHOENIX       | 2003-        | ZA-8P   | ZA-8P   |   |        |
| LINCE         | 125 SERVETTE | -   |   | CL-2I   |        |
|               | 150 SERVETTE | -   |   | CL-3I   |        |
|               | 200 SERVETTE | -   |   |   |        |
| MAICO         | GM STAR 250E | -   |   | CL-2I   |        |
|               | GM STAR 500E | -   |   | CL-3I   |        |
|               | GM STAR SID. | -   |   | NE-6  |        |
|               |              |   |   | NE-6P   |        |
|               |              |   | NE-8  |   |        |
| MALAGUTI      | 50 MDX       | 1986-1991   | ZA-1  | ZA-1  |        |
|               | 50 MEX       | 1986-1991   | ZA-1P   | ZA-1P   |        |
|               | 50 MFX       | 1986-1991   |   |   |        |
|               | 50 MGX       | 1986-1991   |   |   |        |
|               | CUSTOM       | 1986-1991   |   |   |        |
|               | FIFTY FULL   | 1986-   |   |   |        |
|               | FIFTY HF 50  | 1986-1991   |   |   |        |



# MOTOCICLETA

## MOTORCYCLE

| MARCA BRAND     | MODELO MODEL |  |  |  |
|-----------------|--------------|---|---|---|
| <b>MALAGUTI</b> | FIFTY TOP 50 | 1986-   |   |   |
|                 | RUNNER YLC   | 1986-1991   |   |   |
|                 | TOP 50       | 1986-1991   |   |   |
|                 | 125          | 1986-   |   | ZA-1  |
|                 | 125 RUNNER   | 1986-   |   | ZA-1P   |
|                 | CAVALCONE 80 | -   |   |   |
|                 | CHOPPER 25   | -   |   |   |
|                 | CHOPPER 40   | -   |   |   |
|                 | CHOPPER 80   | -   |   |   |
|                 | DRIBBLING    | 1986-   |   |   |
|                 | DROP         | -   |   |   |
|                 | DUNE ES      | 1986-   |   |   |
|                 | DUNE KS      | 1986-   |   |   |
|                 | FIFTY        | -   |   |   |
|                 | FIRE BIRD    | -   |   |   |
|                 | GRIZLY UNO   | -   |   |   |
|                 | MRX ENDURO   | 1986-   |   |   |
|                 | NEW DRIBLING | -   |   |   |
|                 | PULL CX      | -   |   |   |
|                 | CENTRO SL    | 1994  | ZA-4DP  | ZA-4DP  |
|                 | CROSSER 50   | 1994-   |   |   |
|                 | F 10         | 1994  |   |   |
|                 | PHANTOM      | 1994  |   |   |
|                 | RS           | 1991  |   |   |
|                 | F 10 JET     | 1992-   | YAMA-27   | YAMA-27   |
|                 |              |   | YAMA-27D  | YAMA-27D  |
|                 |              |   | YAMA-27DP   | YAMA-27DP   |
|                 |              | YAMA-27P  | YAMA-27P  |   |
|                 |              | YAMA-30P  | YAMA-30P  |   |
| FIREFOX F15     | 1996-1997    | ZA-9P   | ZA-9P   |   |
| MADISON         | 2003-        |   |   |   |
| RST 50          | 1991-1992    | ZA-13P  | ZA-4DP  |   |
|                 |              | ZA-4DP  |   |   |
| <b>MALANCA</b>  | 125 MARKT    | -   | ZA-1  | ZA-1  |
|                 |              |   | ZA-1P   | ZA-1P   |
|                 | BIG          | -   |   | ZA-1  |
|                 | GTS 4 4M     | -   |   | ZA-1P   |
|                 | GTS 5        | -   |   |   |
|                 | LP           | -   |   |   |
|                 | LPRL         | -   |   |   |
| <b>MBK</b>      | BOOSTER      | 1995-1997   | ZA-4DP  | ZA-4DP  |
|                 | EVOLIS       | 1995-   |   |   |
|                 | FORTE        | 1995-   |   |   |
|                 | NEW SORRISO  | 1995-   |   |   |
|                 | BOOSTER      | 1998  | ZA-9P1  | ZA-9P1  |
|                 | KILIBRE      | 2003-   |   |   |
|                 | OVETTO       | 1998  |   |   |
|                 | BOOSTER 50   | -   | YAMA-27   | YAMA-27   |
|                 | EVOLIS       | -   | YAMA-27D  | YAMA-27D  |
|                 | SCOOTER      | -   | YAMA-27DP   | YAMA-27DP   |
|                 | SORRISO      | -   | YAMA-27P  | YAMA-27P  |
|                 | TARGET       | -   | ZA-4DP  | ZA-4DP  |
|                 | <b>MBM</b>   | BREEZE LUSSO  | -   |   |
| BULL            |              | -   |   | ZA-1P   |



| MARCA BRAND          | MODELO MODEL |  |  |  |
|----------------------|--------------|---|---|---|
| <b>MBM</b>           | CRAZY        | -   |   |   |
|                      | PONY         | -   |   |   |
|                      | SOGNO        | -   |   |   |
| <b>MONTESA</b>       | 250 ENDURO   | -1991   |   | CL-2I   |
|                      | 250 KING SC. | -1991   |   | CL-3I   |
|                      | 348 TRIAL    | -1991   |   |   |
|                      | 360 ENDURO   | -1991   |   |   |
|                      | CAPPRA 250   | -1991   |   |   |
|                      | COTA 50      | -1991   |   |   |
|                      | COTA 50 AR.  | -1994   |   |   |
|                      | COTA 50 H20  | -1994   |   |   |
|                      | COTA 123 C   | -1991   |   |   |
|                      | COTA 125     | -1991   |   |   |
|                      | COTA 200     | -1991   |   |   |
|                      | COTA 242 T   | -1991   |   |   |
|                      | COTA 247     | -1991   |   |   |
|                      | COTA 250     | -1991   |   |   |
|                      | COTA 304     | -1991   |   |   |
|                      | COTA 307     | -1991   |   |   |
|                      | COTA 330     | -1991   |   |   |
|                      | COTA 335     | -1991   |   |   |
|                      | COTA 348     | -1991   |   |   |
| COTA 349             | -1991        |   |   |   |
| COTA 350             | -1991        |   |   |   |
| <b>MORINI FRANCO</b> | GIULIETTA O. | -   |   | ZA-1  |
|                      | LEM          | -   |   | ZA-1P   |
| <b>MOTO GUZZI</b>    | 65 GT        | 1984-   | IMS-5   | NE-6  |
|                      | 650 NTX      | 1984-   | IMS-5P  | NE-6P   |
|                      | 850 LE MANS  | 1981-   |   | NE-8  |
|                      | 850 T3 C.    | 1981-   |   |   |
|                      | 850 T3-T4    | 1981-   |   |   |
|                      | V 35         | 1982-1984   |   |   |
|                      | V 35 II      | 1982-1984   |   |   |
|                      | V 35 IMOLA   | 1982-1984   |   |   |
|                      | V 50         | 1990-   |   |   |
|                      | V 50 C       | 1982-1984   |   |   |
|                      | V 50 C       | 1984-   |   |   |
|                      | V 50 CH.     | 1982-   |   |   |
|                      | V 50 III     | 1982-1990   |   |   |
|                      | V 50 III     | 1990-   |   |   |
|                      | V 50 MONZA   | 1982-1984   |   |   |
|                      | V 50 MONZA   | 1984-   |   |   |
|                      | V 50 TS      | 1982-   |   |   |
| V 65                 | -            |   |   |   |
| V 65                 | 1984-        |   |   |   |
| V 65 C               | 1984-        |   |   |   |
| V 65 FL.             | 1984-        |   |   |   |
| V 65 II              | 1984-        |   |   |   |
| V 65 LA.             | 1984-        |   |   |   |
| V 65 SP              | 1984-        |   |   |   |
| V 65 TT              | 1984-        |   |   |   |
| V 75                 | -            |   |   |   |
| V 75                 | 1984-        |   |   |   |
| 125 BX               | 1986-        |   | NE-8  |   |



| MARCA BRAND  | MODELO MODEL |  |  |  |
|--------------|--------------|---|---|---|
| MOTO GUZZI   | 125 CUSTOM   | 1986-   |   |   |
|              | 125 TT       | 1986-   |   |   |
|              | 125 TURISMO  | -   |   | NE-6  |
|              | 850 T3       | 1986-   |   | NE-6P   |
|              | DINGO        | -   |   |   |
|              | STORNELLO    | -   |   |   |
|              | 125 TURISMO  | 1981-   | IMS-5   | NE-8  |
|              | 254          | -   | IMS-5P  |   |
|              | V 35         | 1984-   |   |   |
|              | V 35 C       | 1984-1986   |   |   |
|              | V 35 F.      | 1984-   |   |   |
|              | V 35 II      | 1984-   |   |   |
|              | V 35 III     | 1984-   |   |   |
|              | V 35 IMOLA   | 1984-   |   |   |
|              | V 1000 I LE. | 1984-   |   |   |
|              | V 1000 IDRO. | 1984-   |   |   |
|              | V 1000 II L. | 1984-   |   |   |
|              | 250 ELECTR.  | -   | FEM-2D<br>FEM-2I  | NE-8  |
|              | 250 TS       | -   | FEM-2D  | NE-6  |
|              | 350 GTS      | -   | FEM-2I  | NE-6P   |
|              | 350          | 1979-   | IMS-5   | NE-6  |
|              | 500          | -   | IMS-5P  | NE-6P   |
|              | 850 T5       | 1986-   |   |   |
|              | SP 1000 II   | 1984-   |   |   |
|              | V 1000 CALI. | 1984-   |   |   |
|              | V 1000 CONV. | 1984-   |   |   |
|              | V 1000 GT    | 1984-   |   |   |
|              | V 1000 SP    | 1984-   |   |   |
|              | V 1000 SP II | 1984-   |   |   |
|              | 350 NEVADA   | 1994  | ZA-1  | ZA-1  |
|              | 750 NEVADA   | 1994-   | ZA-1P   | ZA-1P   |
|              | 750          | 1979-   | FEM-1D  | NE-6  |
|              | 850 LE MANS  | 1979-1981   | FEM-1I  | NE-6P   |
| 850 T3       | 1979-1986    | SIP-3   |   |   |
| 850 T3 C.    | 1979-1981    |   |   |   |
| V 1000 C.    | 1979-        |   |   |   |
| 750 NTX      | 1990-        | ZA-1  | NE-8  |   |
| V 75 NTX     | 1990-        | ZA-1P   |   |   |
| 850 GT       | 1986-        | FEM-1D<br>FEM-1I  | NE-6<br>NE-6P   |   |
| 1000 GT RL   | 1990-        | IMS-5   | ZA-1  |   |
| 1000 GT RR   | 1990-        | IMS-5P  | ZA-1P   |   |
| 1000 LE MANS | 1990-        |   |   |   |
| 1000 S       | 1990-        |   |   |   |
| 1000 ST II   | -            |   |   |   |
| 1000 ST III  | -            |   |   |   |
| V 35 C       | 1986-        |   |   |   |
| V 35 GT      | 1986-        |   |   |   |
| V 35 NTX     | 1986-        |   |   |   |
| V 35 TT      | 1986-        |   |   |   |
| BREVA        | 2003-        | ZA-9P1  | ZA-9P1  |   |
| CALIFOR. EV  | 2003-        |   |   |   |
| V 11         | 2003-        |   |   |   |



| MARCA BRAND | MODELO MODEL |  |  |  |
|-------------|--------------|---|---|---|
| MOTO GUZZI  | FAL.SAHARA   | -   | FEM-1D  |   |
|             | V 7 SPORT    | -   | SIP-3   | NE-6<br>NE-6P   |
| MOTO MORINI | V 1000 G5    | 1979-   | IMS-5<br>IMS-5P   | IMS-5<br>IMS-5P   |
|             | 3 1/2 SPO.   | 1981-   | FEM-1D  | NE-6  |
| MOTO MORINI | 3 1/2 V      | 1981-   | FEM-1I  | NE-6P   |
|             | 125 T        | 1981-   |   |   |
| MOTO MORINI | 250          | 1981-   |   |   |
|             | 250 BIC      | 1981-   |   |   |
| MOTO MORINI | 500 GV       | -   |   |   |
|             | 500 KANGEROO | -   |   |   |
| MOTO MORINI | 500 T/S      | -   |   |   |
|             | 50 CORSARIO  | -   |   | NE-6  |
| MOTO MORINI | 125 CORSARIO | -   |   | NE-6P   |
|             | 250 KANGURO  | 1979-   |   |   |
| MOTO MORINI | 250 STRADA   | 1979-   |   |   |
|             | 550          | 1979-   |   |   |
| MOTO MORINI | 125 H        | 1984-   | FEM-2D  | ZA-1  |
|             | 125 KJ       | 1984-   | FEM-2I  | ZA-1P   |
| MOTO MORINI | 350 COGUARO  | 1986-   | AF-6D   | ZA-1  |
|             | 350 EXCALIB. | 1986-   |   | ZA-1P   |
| MOTO MORINI | 350 KANGURO  | 1986-   |   |   |
|             | 350 NEW YORK | 1986-   |   |   |
| MOTO MORINI | 350 XE       | 1986-   |   |   |
|             | 501 COGUARO  | 1986-   |   |   |
| MOTO MORINI | 501 EXCALIB. | 1986-   |   |   |
|             | 501 KANGURO  | 1986-   |   |   |
| MOTO MORINI | 501 NEW YORK | 1986-   |   |   |
|             | 500 CAMEL    | -   | AF-6D   | NE-8  |
| MOTOBECANE  | 125 LT       | -   | LAS-X   | NE-6  |
|             | SUPERMOBY 51 | -   |   | NE-6P   |
| MOTOBI      | 254          | -   | IMS-5<br>IMS-5P   | NE-8  |
|             | 3/TRE-RCV    | -   |   | ZA-1  |
| MOTRON      | MST          | -   |   | ZA-1P   |
|             | RA PL 4P     | -   |   |   |
| MOTRON      | SU 3R 1D     | -   |   |   |
|             | TAXI AP      | -   |   |   |
| MOTRON      | TAXI ES 1D   | -   |   |   |
|             | COMPACT      | 1990-1991   | ZA-1  | ZA-1  |
| MOTRON      | GL 4         | 1990-1991   | ZA-1P   | ZA-1P   |
|             | GTO          | 1990-1991   |   |   |
| MOTRON      | INVADER      | 1990-1991   |   |   |
|             | SHOPPING     | 1990-1991   |   |   |
| MOTRON      | TAXI ES ID   | 1990-1991   |   |   |
|             | TAXI KS SL   | 1990-1991   |   |   |
| MV AUGUSTA  | 125 S        | -   | FEM-1I  |   |
|             | 125 SPORT    | -   |   | FEM-1I  |
| MV AUGUSTA  | 350 SPORT    | -   |   | FEM-2I  |
|             | 350 S        | -   | AF-7I<br>AF-7IP   | AF-7I<br>AF-7IP   |
| MV AUGUSTA  | 750 S        | -   | SUZU-13P<br>SUZU-4I   | NE-6<br>NE-6P   |



# MOTOCICLETA

## MOTORCYCLE

| MARCA BRAND       | MODELO MODEL |  |  |  |
|-------------------|--------------|---|---|---|
| <b>MV AUGUSTA</b> |              |   | SUZU-4IP  |   |
| <b>MZ</b>         | TOUR         | 1994  | ZA-4DP  |   |
| <b>NORTON</b>     | 850 COMMANDO | -   | UN-3  |   |
| <b>OMC</b>        | CITY         | -   |   | ZA-1  |
|                   | ELITE        | -   |   | ZA-1P   |
|                   | ELITE SL     | -   |   |   |
|                   | ELS-SL       | -   |   |   |
|                   | EXCLAIM      | -   |   |   |
|                   | HI TECH      | -   |   |   |
|                   | MARINER-SL   | -   |   |   |
|                   | MUDDY        | -   |   |   |
|                   | MUDDY JUNIOR | -   |   |   |
|                   | WILD ELITE   | -   |   |   |
|                   | WILD MS      | -   |   |   |
|                   | WILD TIGRE   | -   |   |   |
| <b>OSSA</b>       | 125          | -   | CAS-1D  | NE-6  |
|                   | 250 ENDURO   | -   |   | NE-6P   |
|                   | 350 ENDURO   | -   |   |   |
|                   | 250 DESERT   | -   |   | CL-2I   |
|                   | 250 EXPLORER | -   |   | CL-3I   |
|                   | 250 FUEGO    | -   |   |   |
|                   | 250 ORANGE   | -   |   |   |
|                   | 250 SUPER    | -   |   |   |
|                   | 250 TRIAL    | -   |   |   |
|                   | 250 TU       | -   |   |   |
|                   | 250 TURISMO  | -   |   |   |
|                   | 250 YO       | -   |   |   |
|                   | 350 EXPLORER | -   |   |   |
|                   | 350 ORANGE   | -   |   |   |
|                   | 350 TRIAL    | -   |   |   |
|                   | TRIAL 303    | -   |   |   |
|                   | TRIAL JELLOW | -   |   |   |
| <b>PERIPOLI</b>   | COLORADO     | -   |   | ZA-1  |
|                   | DAY LXR/SA   | -   |   | ZA-1P   |
|                   | DAY S 5/K    | -   |   |   |
|                   | GIULIETTA    | -   |   |   |
|                   | MINI L SAM1K | -   |   |   |
|                   | OXFORD       | -   |   |   |
|                   | OXFORD ROAD  | -   |   |   |
|                   | TIR          | -   |   |   |
|                   | VAI M03      | -   |   |   |
|                   | VAI R        | -   |   |   |
|                   | WILD         | -   |   |   |
| <b>PEUGEOT</b>    | BUXY         | 1994-1997   | ZA-12   | ZA-12   |
|                   | FOR LUX      | 1994-1998   |   |   |
|                   | SPEEDAKE     | 1995-1997   |   |   |
|                   | SQUAB        | 1995-1996   |   |   |
|                   | ZENITH       | 1994-1996   |   |   |
|                   | LOOXOR       | 2001  |   | NE-45   |
|                   | LUDIX        | 2004  |   | NE-45P  |
|                   | SPEEDFIGHT   | 1997  |   |   |
|                   | SV GEO       | 1991-1995   |   |   |
|                   | TREKKER      | 1998  |   |   |
|                   | VIVACITY     | 1999  |   |   |



| MARCA BRAND    | MODELO MODEL |  |  |  |
|----------------|--------------|---|---|---|
| <b>PEUGEOT</b> | X-RACE       | 2003  |   |   |
|                | SC 50 L SCO. | -   | SUZU-13P  | SUZU-13P  |
|                | SC 80 L SCO. | -   | SUZU-4I   | SUZU-4I   |
|                | ST 50 L SCO. | -   | SUZU-4IP  | SUZU-4IP  |
|                | SV 125 SCO.  | -   |   |   |
|                | SQUAB        | 1997  | NE-45P  |   |
|                | SV 50 GEO    | 1992-   | NE-45   | NE-45   |
|                | SV 80 GEO    | 1993-   | NE-45P  | NE-45P  |
|                | SV 125 GEO   | 1993-   |   |   |
| <b>PGO</b>     | COMET        | 2000-   | PGO-2P  |   |
|                | PMS          | 2000-   |   |   |
|                | PMX          | 2000-   |   |   |
|                | RODOSHOW     | 2000-   |   |   |
|                | TREX         | 2000-   |   |   |
|                | SCOOTER      | -   | PGO-1   |   |
| <b>PIAGGIO</b> | APE 600 MP   | 1979-1981   |   | AF-6D   |
|                | APE CAR      | -   | AF-9D   | FAB-1   |
|                | APE CAR P3   | -   | AF-9DP  |   |
|                | APE CARP 601 | -   | AF-9I   |   |
|                |              |   | AF-9IP  |   |
|                |              |   | FEM-1D  |   |
|                |              |   | FEM-1I  |   |
|                | APE P 50     | -   | FEM-1D  | NE-6  |
|                | APE TM P 50  | -   | FEM-1I  | NE-6P   |
|                | VESPA 50     | 1979-1983   |   |   |
|                | VESPA 50 ES  | 1981-1983   |   |   |
|                | APE TM 703   | -   | AF-9D   | FAB-1   |
|                | NICA 125     | -   | AF-9DP  |   |
|                |              |   | AF-9I   |   |
|                |              |   | AF-9IP  |   |
|                | BOSS 50      | 1986-   |   | ZA-1  |
|                | BRAVO        | 1992-   |   | ZA-1P   |
|                | BRAVO 50     | 1986-   |   |   |
|                | CIAO         | 1992-   |   |   |
|                | CIAO 50      | 1986-   |   |   |
|                | GRILLO       | 1992-   |   |   |
|                | GRILLO 50    | 1986-   |   |   |
|                | SI           | 1992-   |   |   |
|                | SI 50        | 1986-   |   |   |
|                | BOXER 50     | 1982-1986   |   | NE-8  |
|                | BRAVO 50     | 1982-1986   |   | ZA-1  |
|                | CIAO 50      | 1982-1986   |   | ZA-1P   |
|                | SI 50        | 1982-1986   |   |   |
|                | CARNABY      | 2007  |   | FI-13P1   |
|                | FLY          | 2005-2012   |   |   |
|                | SKIPPER      | 1999-2000   |   |   |
|                | VESPA        | 1996  |   |   |
|                | ZIP          | 2000-2011   |   |   |
|                | COSA 125     | 1988-   | ZA-2P   | ZA-2P   |
|                | COSA 150     | 1988-   |   |   |
|                | COSA 200     | 1988-   |   |   |
|                | SFERA        | 1992-   |   |   |
|                | VESPA 50 PK  | 1986-   |   |   |
|                | VESPA FL 2   | 1986-   |   |   |



| MARCA BRAND  | MODELO MODEL |  |  |  |
|--------------|--------------|---|---|---|
| PIAGGIO      | VESPA PLURI. | 1986-   |   |   |
|              | VESPA RUSH   | 1986-   |   |   |
|              | COSA 125 MA  | 1992-   | FI-1  | FI-1  |
|              | COSA 150 MA  | 1992-   | FI-1P   | FI-1P   |
|              | COSA 2 125   | 1993-   | ZA-2P   | ZA-2P   |
|              | COSA 2 150   | 1993-   |   |   |
|              | COSA 2 200   | 1993-   |   |   |
|              | COSA 200 MA  | 1992-   |   |   |
|              | VESPA 125 E  | 1984-   |   |   |
|              | VESPA P 125  | -   |   |   |
|              | VESPA P 125  | 1984-1991   |   |   |
|              | VESPA PK 125 | -   |   |   |
|              | VESPA PX 125 | 1984-1991   |   |   |
|              | VESPA PX 150 | 1984-1991   |   |   |
|              | VESPA PX 200 | 1984-   |   |   |
|              | FREE RL      | 1995  | ZA-7DP  |   |
|              | HEXAGON 125  | 1994-1997   | ZA-4DP  | ZA-4DP  |
|              | NRG          | 2002-2005   |   | ZA-7DP  |
|              | SKIPPER      | 1993-1998   |   |   |
|              | TYPHOON      | 1994-2010   |   |   |
|              | ZIP          | 1994-1999   |   |   |
|              | NRG          | 2006  |   | ZA-9P   |
|              | QUARTZ       | 1992-   | ZA-2P   | ZA-2P   |
|              | VESPA 50     | 1992-   | ZA-7DP  | ZA-7DP  |
|              | ZIP          | 1992-1993   |   |   |
|              | SCATTO       | -1991   | ZA-13P  | ZA-13P  |
|              | SFERA        | 1995-1998   | ZA-7DP  | ZA-7DP  |
|              | TOLEDO-SC    | -   |   | CL-2I<br>CL-3I  |
|              | VESPA 125 E  | 1981-1984   |   | NE-6  |
|              | VESPA 150    | 1979-   |   | NE-6P   |
|              | VESPA 150 RA | 1979-   |   |   |
|              | VESPA 150 SV | 1979-   |   |   |
| VESPA P 80X  | -            |   |   |   |
| VESPA P 125X | 1981-        |   |   |   |
| VESPA P 150X | 1981-        |   |   |   |
| VESPA P 200X | 1981-        |   |   |   |
| VESPA PX 200 | 1986-        |   |   |   |
| VESPA PX125E | 1981-        |   |   |   |
| VESPA 125 ET | 1979-        | FEM-1D  | ZA-1  |   |
| VESPA 200 PX | 1979-        | FEM-1I  | ZA-1P   |   |
| VESPA P 150X | 1979-1981    |   |   |   |
| VESPA 125ET3 | -1979        | FEM-1I  | NE-6<br>NE-6P   |   |
| VESPA PK 50  | 1984-1986    | FI-1  | FI-1  |   |
| VESPA PK 50S | 1984-1986    | FI-1P   | FI-1P   |   |
| RALEIGH      | CICLI        | -   |   | LF-2  |
|              | CYCLES       | -   |   | UN-FP   |
| RIZZATO      | ATALA        | 1995  | ZA-4DP  |   |
|              | HACKET AT12  | 1995  |   |   |
|              | HACKET RACI. | 1995  |   |   |
| SULKI        | 50           | -1992   | BH-4  | BH-4  |
|              | 125          | 1992-   |   |   |
| SUZUKI       | 400 ENDURO   | 1978-   | SUZU-13P  |   |



| MARCA BRAND | MODELO MODEL |  |  |  |
|-------------|--------------|---|---|---|
| SUZUKI      | 400 S        | 1978-   | SUZU-4I   |   |
|             | GS 400 T     | -   | SUZU-4IP  |   |
|             | GT 350       | 1978-   |   |   |
|             | GT 500       | 1978-   |   |   |
|             | 650 DJEBEL   | -1991   | SUZU-13P  | SUZU-13P  |
|             | DR 125 S     | -   | SUZU-4I   | SUZU-4I   |
|             | DR 250 S     | 1984-   | SUZU-4IP  | SUZU-4IP  |
|             | DR 400       | 1980-1985   |   |   |
|             | DR 500       | 1984-1986   |   |   |
|             | DR 600       | 1985-   |   |   |
|             | DR 650       | 1990-1991   |   |   |
|             | DR 750 BIG   | 1988-1991   |   |   |
|             | DR 800 SL    | 1990-   |   |   |
|             | GS 125 ES    | 1984-   |   |   |
|             | GS 550       | 1984-1985   |   |   |
|             | GS 850       | 1980-1982   |   |   |
|             | RGT 125      | -   |   |   |
|             | TS 125 S     | -   |   |   |
|             | TS 125 X     | -   |   |   |
|             | ADDRESS      | 1992-   | SUZU-11D  | SUZU-11D  |
|             | ADDRESS 100  | 1994  | SUZU-11DP   | SUZU-11DP   |
|             | DR 350 SE    | 1994  |   |   |
|             | DR 650       | 1992-   |   |   |
|             | GS 400       | 1993-   |   |   |
|             | GS 500       | 1989-   |   |   |
|             | GS 750       | 1991-   |   |   |
|             | GSF 400      | 1993-   | SUZU-13P  | SUZU-13P  |
|             | GSF 500 EP   | 1993-   | SUZU-4I   | SUZU-4I   |
|             | GSF 600      | 1995  | SUZU-4IP  | SUZU-4IP  |
|             | GSX 600      | 1989-1997   | SUZU-5  | SUZU-5  |
|             | GSX 750      | 1988  | SUZU-5P   | SUZU-5P   |
|             | GSX 1100 92  | 1992-   | SUZU-13P  | NE-8  |
|             | GSXR 750     | 1989-1996   | SUZU-4I   | SUZU-13P  |
|             | GSXR 1100    | 1990-   | SUZU-4IP  | SUZU-4I   |
|             | RF 600 R     | 1993-   | SUZU-5  | SUZU-4IP  |
|             | RF 900 R     | 1994-   | SUZU-5P   | SUZU-5  |
|             | RG 125       | 1995  |   | SUZU-5P   |
|             | RS 650       | 1991  | SUZU-12DP   |   |
|             | VS 750       | 1989-   |   |   |
|             | VS 800       | 1992-   |   |   |
|             | VS 1400      | 1990-   |   |   |
|             | VX 800       | 1990-   |   |   |
| AH 50       | 1991-        | YAMA-20I  | YAMA-20I  |   |
| CP 50       | 1991-        | YAMA-24IP   | YAMA-24IP   |   |
|             |              | YAMA-28P  | YAMA-28P  |   |
| AJ 50 ZZ    | 1995         | ZA-4DP  | ZA-4DP  |   |
| AP 50       | 1995         |   |   |   |
| AN 125      | 1995         | YAMA-23DP   | NE-8  |   |
| VS 600 GL   | 1995         | YAMA-23IP   |   |   |
| VS 800 GL   | 1995         |   |   |   |
| CC 1        | -            | SUZU-13P  | NE-8  |   |
| RV 90       | -            | SUZU-4I   |   |   |
|             |              | SUZU-4IP  |   |   |
| DL 1000     | 2003-        | SUZU-12DP   | SUZU-12DP   |   |



# MOTOCICLETA

## MOTORCYCLE

| MARCA BRAND | MODELO MODEL |  |  |  |
|-------------|--------------|---|---|---|
| SUZUKI      | DR 650 RSE   | 1995-   | YAMA-19D  | YAMA-19D  |
|             | GS 500 F     | 2004-   | YAMA-19DP   | YAMA-19DP   |
|             | GS 500 E     | 1995-   | YAMA-19I  | YAMA-19I  |
|             | GSF 600      | 1995-   | YAMA-19IP   | YAMA-19IP   |
|             | GSF BANDIT   | 2004-   | YAMA-20D  | YAMA-20D  |
|             | GSX R1300    | 2004-   | YAMA-20I  | YAMA-20I  |
|             | GSXR 750 SP  | 1995-   | YAMA-20IP   | YAMA-20IP   |
|             | GSXR 750 W   | 1995-   | YAMA-22DP   | YAMA-22DP   |
|             | GSXR 1000    | 2003-   | YAMA-22IP   | YAMA-22IP   |
|             | GSXR 1100    | 1995-   | YAMA-23DP   | YAMA-23DP   |
|             | GZ 250       | 2004-   | YAMA-23IP   | YAMA-23IP   |
|             | LR GSX 600   | 2004-   | YAMA-24DP   | YAMA-24DP   |
|             | SV 650 S     | 2003-   | YAMA-24IP   | YAMA-24IP   |
|             | SV 1000 S    | 2003-   | YAMA-28P  | YAMA-28P  |
|             | SV 650       | 2004-   | YAMA-29P  | YAMA-29P  |
|             | SV 750       | 2004-   | AF-6D   | NE-6  |
|             | VL 800       | 2004-   |   |   |
|             | V-STROM 650  | 2004-   |   |   |
|             | V-STROM 1000 | 2004-   |   |   |
|             | VZ 1600      | 2004-   |   |   |
|             | DR 125 SE    | 1995  | YAMA-20D  | NE-8  |
|             | LS 650       | 1995  | YAMA-20I  |   |
|             | VS 1400 GLP  | 1995  | YAMA-20IP   |   |
|             | DR 350       | 1997  | YAMA-20I  |   |
|             | DR 350 S     | 1993-   | YAMA-20D  | NE-8  |
|             | DR 350 SM    | 1992-   | YAMA-20I  |   |
|             | DR 350 SN    | 1992-   | YAMA-24DP   |   |
|             | VS 750 J.    | -   | YAMA-24IP   |   |
|             |              |   | YAMA-28P  |   |
|             | G 450 L      | 1980-   | SUZU-5  | SUZU-5  |
|             | GN 400       | 1985-   | SUZU-5P   | SUZU-5P   |
|             | GNX 250      | 1985-1991   |   |   |
|             | GR 650       | 1982-   |   |   |
|             | GS 450       | 1980-   |   |   |
|             | GS 500       | 1984-1989   |   |   |
|             | GS 550       | 1982-1984   |   |   |
|             | GS 750       | 1982-1987   |   |   |
|             | GS 850       | 1982-1985   |   |   |
|             | GSX 250 S    | 1985-1991   |   |   |
|             | GSX 400      | 1985-   |   |   |
|             | GSX 500      | 1989-   |   |   |
|             | GSX 550      | 1985-   |   |   |
|             | GSXR 1100    | 1981-   |   |   |
|             | LS 650       | 1982-   |   |   |
|             | LT 250 A     | 1985-1991   |   |   |
|             | RG 250 R     | 1985-1991   |   |   |
|             | RGV 250      | 1985-1991   |   |   |
|             | GS 1000      | 1982-1985   | SUZU-13P  | SUZU-13P  |
|             | GSX 1100     | 1981-1985   | SUZU-4I   | SUZU-4I   |
|             | RG 500       | 1985-   | SUZU-4IP  | SUZU-4IP  |
|             |              | SUZU-5  | SUZU-5  |   |
|             |              | SUZU-5P   | SUZU-5P   |   |
| GSX 600     | 1998-2006    |   | SUZU-12D  |   |
| GSX 750     | 1988-2006    |   | SUZU-12DP   |   |

| MARCA BRAND | MODELO MODEL |  |  |  |
|-------------|--------------|---|---|---|
| SUZUKI      | GSX 1300 HA. | 1999-2006   |   |   |
|             | TL 1000      | 1997-2002   |   |   |
|             | TU 125       | 1999  |   |   |
|             | TU 250       | 1997-2001   |   |   |
|             | GSX 1200     | 1999-2000   |   |   |
|             | GSX 1400     | 2002-2005   |   |   |
|             | GZ 125       | 1998  |   |   |
|             | RV 125       | 2003  |   |   |
|             | XF 650       | 1997-2001   |   |   |
|             | GSX 750      | 1981-1987   | SUZU-13P  | NE-8  |
|             |              |   | SUZU-4I   | SUZU-13P  |
|             |              |   | SUZU-4IP  | SUZU-4I   |
|             |              |   | SUZU-5  | SUZU-4IP  |
|             |              |   | SUZU-5P   | SUZU-5  |
|             |              |   |   | SUZU-5P   |
|             | GSXR 600     | 1997  | SUZU-12DP   |   |
|             | GSXR 750     | 1997  |   |   |
|             | GT 550       | 1978-   | SUZU-3I   |   |
|             | GT 750       | 1978-   |   |   |
|             | INTRUDE.1400 | 1993-   | YAMA-19D  | NE-8  |
|             | VS 800 GL    | 1993-1995   | YAMA-19DP   |   |
|             |              |   | YAMA-19I  |   |
|             |              |   | YAMA-19IP   |   |
|             |              |   | YAMA-23DP   |   |
|             |              |   | YAMA-23IP   |   |
|             |              |   | YAMA-29P  |   |
|             | KATANA       | 1997  | ZA-4DP  |   |
|             | KATANA R     | 2004-   | ZA-9P1  | ZA-9P1  |
|             | VS 750 INT.  | 1986-   | YAMA-18D  | YAMA-18D  |
|             |              |   | YAMA-18DP   | YAMA-18DP   |
|             |              | YAMA-18I  | YAMA-18I  |   |
|             |              | YAMA-18IP   | YAMA-18IP   |   |
|             |              | YAMA-19D  | YAMA-19D  |   |
|             |              | YAMA-19DP   | YAMA-19DP   |   |
|             |              | YAMA-19I  | YAMA-19I  |   |
|             |              | YAMA-19IP   | YAMA-19IP   |   |
|             |              | YAMA-20D  | YAMA-20D  |   |
|             |              | YAMA-20I  | YAMA-20I  |   |
|             |              | YAMA-20IP   | YAMA-20IP   |   |
|             |              | YAMA-22DP   | YAMA-22DP   |   |
|             |              | YAMA-22IP   | YAMA-22IP   |   |
|             |              | YAMA-23DP   | YAMA-23DP   |   |
|             |              | YAMA-23IP   | YAMA-23IP   |   |
|             |              | YAMA-24DP   | YAMA-24DP   |   |
|             |              | YAMA-24IP   | YAMA-24IP   |   |
|             |              | YAMA-28P  | YAMA-28P  |   |
|             |              | YAMA-29P  | YAMA-29P  |   |
| SWM         | 124 RZ       | -   | AF-6D   | NE-6  |
|             | 280 GS       | -   |   | NE-6P   |
|             | EXPLORER 125 | -   |   |   |
|             | EXPLORER 350 | -   |   |   |
|             | GS 125       | -   |   |   |
|             | GT 125       | -   |   |   |
| GTS 125     | -            |   |   |   |



| MARCA BRAND | MODELO MODEL |  |  |  |
|-------------|--------------|---|---|---|
| SWM         | RS 125       | -   |   |   |
|             | RS 250       | -   |   |   |
|             | TL 329       | -   |   |   |
|             | 350 XN       | -   | ZA-1  | ZA-1  |
|             |              |   | ZA-1P   | ZA-1P   |
|             | WPM 1        | -   |   | NE-6<br>NE-6P   |
| TESTI       | CRICHET PULL | -   |   | NE-6<br>NE-6P   |
| TRIUMPH     | AMERICA      | 2006-   | TRP-1D  |   |
|             | BONNEVILLE   | 2006-   | ZA-9P1  |   |
|             | DAYTONA      | 2006-   |   |   |
|             | ROCKET III   | 2006-   |   |   |
|             | SCRAMBLER    | 2006-   |   |   |
|             | SPEEDMASTER  | 2006-   |   |   |
|             | SPRINT ST    | 2006-   |   |   |
|             | THRUXTON     | 2006-   |   |   |
|             | TIGER        | 2006-2009   |   |   |
|             |              | TRIDENT   | -   | UN-3  |
| YAMAHA      | 250 COMPETI. | -   | YAMA-3I   | YAMA-3I   |
|             | 400          | -   | YAMA-14I  | YAMA-14I  |
|             | RD 400       | -   | YAMA-15D  | YAMA-15D  |
|             |              |   | YAMA-15I  | YAMA-15I  |
|             | 400 BICILIN. | -   | YAMA-17D  | YAMA-17D  |
|             |              |   | YAMA-17I  | YAMA-17I  |
|             | 500          | 1979-   | YAMA-9I   | YAMA-9I   |
|             | 500 ENDURO   | 1979-   | YAMA-14I  | YAMA-14I  |
|             | RD 500       | 1979-   |   |   |
|             | TT 350       | 1995  |   |   |
|             | 600 ACERBIS  | 1980-   | YAMA-14D  | YAMA-14D  |
|             | OHC 650      | 1980-   | YAMA-14I  | YAMA-14I  |
|             | RD 50 M      | -   |   |   |
|             | XT 50        | -   |   |   |
|             | AEROX        | 1998  | ZA-9P1  | ZA-9P1  |
|             | BT 1100 BU.  | 2003-   |   |   |
|             | MAJESTY 250  | 2005-   |   |   |
|             | NEOS         | 1998  |   |   |
|             | VERSITY 300  | 2003-   |   |   |
|             | AXIS         | 1995-   | ZA-4DP  | ZA-4DP  |
|             | BREEZE       | 1994  |   |   |
|             | BREEZE       | 1995-   |   |   |
|             | SPY          | 1995-   |   |   |
|             | BL 125 BE.   | 1984-1991   | YAMA-18D  | NE-8  |
|             | DT 125 BA.   | 1984-1991   | YAMA-18DP   |   |
|             | DT 125 BB.   | 1984-1991   | YAMA-18I  |   |
|             | DT 125 CF.   | 1984-1991   | YAMA-18IP   |   |
| DT 125 R    | 1984-1986    | YAMA-19D  |   |   |
| FZ 400      | 1984-        | YAMA-19DP   |   |   |
| FZR 400     | 1984-        | YAMA-19I  |   |   |
| FZR 600     | 1984-1992    | YAMA-19IP   |   |   |
| RD 350      | 1984-1991    | YAMA-20D  |   |   |
| RD 350 LC   | 1984-1991    | YAMA-20I  |   |   |
| RD 550      | 1984-        | YAMA-20IP   | YAMA-14D  |   |



| MARCA BRAND | MODELO MODEL |  |  |  |
|-------------|--------------|---|---|---|
| YAMAHA      | RT 125 LL    | 1984-1991   | YAMA-22DP   | YAMA-14I  |
|             | SCROW 225    | 1984-1991   | YAMA-22IP   | YAMA-15D  |
|             | SR 250       | 1984-1991   | YAMA-23DP   | YAMA-15I  |
|             | SR 250 SE    | 1984-   | YAMA-23IP   | YAMA-3D   |
|             | SR 250 SP.   | 1984-   | YAMA-24DP   | YAMA-3I   |
|             | SR 500 G-S   | 1984-   | YAMA-24IP   | YAMA-21I  |
|             | SR 600       | 1984-   | YAMA-28P  | YAMA-21IP   |
|             | TDR 125      | 1984-1991   | YAMA-29P  |   |
|             | TDR 250      | 1984-1991   |   |   |
|             | TR 1         | 1984-   |   |   |
|             | TZR 125      | 1984-1991   |   |   |
|             | TZR 250      | 1984-1991   |   |   |
|             | XD 250 LC    | 1984-   |   |   |
|             | XJ 600       | 1984-   |   |   |
|             | XJ 650 SP.   | 1984-   |   |   |
|             | XJ 650 TT.   | 1984-   |   |   |
|             | XJ 750 NS    | 1984-   |   |   |
|             | XJ 750 SE.   | 1984-   |   |   |
|             | XJ 900 F     | 1984-   |   |   |
|             | XJ 900 S     | 1984-   |   |   |
|             | XS 350       | 1984-1991   |   |   |
|             | XS 850       | 1984-   |   |   |
|             | XT 400 SP.   | 1984-   |   |   |
|             | XT 500       | 1984-   |   |   |
|             | XT 550       | 1984-   |   |   |
|             | XT 600       | 1984-1991   |   |   |
|             | XT 600 4V.   | 1984-1991   |   |   |
|             | XT 600 N     | 1984-   |   |   |
|             | XT 600 TE.   | 1984-1991   |   |   |
|             | XT 600 YD.   | 1984-   |   |   |
|             | XT 600 Z-ZA  | 1984-1991   |   |   |
|             | XU 500 SE    | 1984-   |   |   |
|             | XV 535       | 1984-   |   |   |
|             | XV 1000 SE   | 1984-   |   |   |
|             | XZ 550 LC-S  | 1984-   |   |   |
| YZ 125 LC   | 1984-1991    |   |   |   |
| YZ 250 LC   | 1984-1991    |   |   |   |
| YZ 490      | 1984-        |   |   |   |
| BL 125 BE.  | 1991-        | YAMA-18D  | NE-8  |   |
| DT 125 BA.  | 1991-        | YAMA-18DP   |   |   |
| DT 125 BB.  | 1991-        | YAMA-18I  |   |   |
| DT 125 CF.  | 1991-        | YAMA-18IP   |   |   |
| DT 125 R    | 1991-1992    | YAMA-19D  |   |   |
| RD 350      | 1991-        | YAMA-19DP   |   |   |
| RD 350 LC   | 1991-        | YAMA-19I  |   |   |
| RT 125 LL.  | 1991-        | YAMA-19IP   |   |   |
| SCROW 225   | 1991-        | YAMA-20D  |   |   |
| SR 250      | 1991-        | YAMA-20I  |   |   |
| TDR 125     | 1991-1992    | YAMA-20IP   |   |   |
| TDR 250     | 1991-        |   |   |   |
| TT 350      | 1991-1995    |   |   |   |
| TZR 125 R   | 1991-1992    |   |   |   |
| TZR 250     | 1991-        |   |   |   |
| XT 600      | 1991-        |   |   |   |





# MOTOCICLETA

## MOTORCYCLE

| MARCA BRAND  | MODELO MODEL |  |  |  |
|--------------|--------------|---|---|---|
| YAMAHA       | XT 600 4V.   | 1991-   |   |   |
|              | XT 600 TE.   | 1991-   |   |   |
|              | XT 600 Z-ZA  | 1991-   |   |   |
|              | YZ 125 LC    | 1991-   |   |   |
|              | YZ 250 LC    | 1991-   |   |   |
|              | CR 50 Z      | 1992-   | YAMA-27   | YAMA-27   |
|              | CT 50 S      | 1992-   | YAMA-27P  | YAMA-27P  |
|              | SCOOTER MBK  | 1991-   |   |   |
|              | CT 50 SS     | 1995  | YAMA-27DP   | YAMA-27DP   |
|              |              |   | YAMA-27P  | YAMA-27P  |
|              | DT 125       | -1985   | YAMA-3D   | YAMA-3D   |
|              | DT 125 LC.   | -1985   | YAMA-3I   | YAMA-3I   |
|              | TX 650       | 1979-   |   |   |
|              | TX 750       | 1979-   |   |   |
|              | DT 125       | 1992-   | YAMA-18D  | YAMA-18D  |
|              | DT 125 B     | 1992-   | YAMA-18I  | YAMA-18I  |
|              | DT 125 R     | 1992-   | YAMA-19D  | YAMA-19D  |
|              | DT 125 Z     | 1992-   | YAMA-19I  | YAMA-19I  |
|              | TT 600       | 1993  | YAMA-20D  | YAMA-20D  |
|              | TT 600 S     | 1991-   | YAMA-20I  | YAMA-20I  |
|              | TZR 125 R    | 1992-   | YAMA-22DP   | YAMA-22DP   |
|              | TZR 125 RSP  | 1992-   | YAMA-22IP   | YAMA-22IP   |
|              | XT 600 A     | 1993-   | YAMA-23DP   | YAMA-23DP   |
|              | XT 600 E     | 1991-   | YAMA-23IP   | YAMA-23IP   |
|              | XT 600 ZA    | 1991-1992   | YAMA-24DP   | YAMA-24DP   |
|              |              |   | YAMA-24IP   | YAMA-24IP   |
|              |              |   | YAMA-28P  | YAMA-28P  |
|              |              |   | YAMA-29P  | YAMA-29P  |
|              | DT 125 CO.   | 1986-1992   | ZA-1  | ZA-1  |
|              | DT 125 LC.   | 1986-1992   | ZA-1P   | ZA-1P   |
|              | DT 125 R     | 1986-1991   |   |   |
|              | DT 250       | -   | YAMA-14D  | YAMA-14D  |
|              | DT 250 MX    | -   | YAMA-14I  | YAMA-14I  |
|              | RD 250       | -   | YAMA-15D  | YAMA-15D  |
|              |              |   | YAMA-15I  | YAMA-15I  |
|              |              |   | YAMA-3D   | YAMA-3D   |
|              |              |   | YAMA-3I   | YAMA-3I   |
|              | FJ 1100      | 1984-   | YAMA-21I  | YAMA-21I  |
|              | FJ 1200      | 1984-   | YAMA-21IP   | YAMA-21IP   |
|              | FS 1200      | 1984-   |   |   |
|              | FZ 600       | 1984-   | YAMA-23IP   |   |
|              | FZ 600 GE.   | 1984-   | YAMA-24DP   |   |
|              | FZ 750 A-R   | 1984-   | YAMA-24IP   |   |
| FZR 600      | 1992-        | YAMA-28P  |   |   |
| FZR 1000     | 1984-        | YAMA-29P  |   |   |
| FZR 1000 E.  | 1984-        | YAMA-5D   | YAMA-5D   |   |
| FZX 750      | 1984-        | YAMA-5I   | YAMA-5I   |   |
| GENESIS FZR  | 1992-        | YAMA-14I  | NE-8  |   |
| RD 500 YP.   | 1984-        |   |   |   |
| SUPER T. 750 | 1992-        |   |   |   |
| TDM 850      | 1991-        | YAMA-18I  | ZA-1  |   |
| TT 350       | 1984-1991    | YAMA-18IP   | ZA-1P   |   |
| TT 600 S     | 1984-1991    | YAMA-19I  | ZA-1  |   |

| MARCA BRAND | MODELO MODEL |  |  |  |
|-------------|--------------|---|---|---|
| YAMAHA      | V MAX 86     | 1984-   | YAMA-19IP   | ZA-1P   |
|             | VMX 12 N     | 1984-   | YAMA-20D  | YAMA-20D  |
|             | XJ 400       | 1984-   |   |   |
|             | XJ 600 N     | 1984-   |   |   |
|             | XJ 650 T     | 1984-   |   |   |
|             | XJ 650 TU.   | 1984-   |   |   |
|             | XJ 750 N     | 1984-   |   |   |
|             | XJ 750 S.    | 1984-   |   |   |
|             | XTZ 750      | 1984-   |   |   |
|             | XTZ 750 T.   | 1984-   |   |   |
|             | XV 500 SE    | 1984-   |   |   |
|             | XV 750 SE    | 1984-   |   |   |
|             | XV 1000 V.   | 1984-   |   |   |
|             | XV 1100      | 1984-   |   |   |
|             | XZV 12 T     | 1984-   |   |   |
|             | XZV 12 TD    | 1984-   |   |   |
|             | XZV 13 TD    | 1984-   |   |   |
|             | FRZ 600      | 1995-   | YAMA-26   | YAMA-26   |
|             | FRZ 600 R    | 1994-   | YAMA-26D  | YAMA-26D  |
|             | FZX 600 R    | 1995-   | YAMA-26DP   | YAMA-26DP   |
|             | GTS 1000     | 1993-   | YAMA-26P  | YAMA-26P  |
|             | GTS 1000 ABS | 1993-   |   |   |
|             | TDM          | 1996-   |   |   |
|             | TDM 850      | 1995-   |   |   |
|             | TRX 850      | 1995-   |   |   |
|             | XJ 600 E     | 1995-   |   |   |
|             | XJ 600 S D.  | 1995-   |   |   |
|             | XJ 900 S D.  | 1995-   |   |   |
|             | XT 500       | 1979-1984   |   |   |
|             | XT 600 E     | 1995-   |   |   |
|             | XTZ 660      | 1994-   |   |   |
|             | XVS 110 D.S. | 1998-   |   |   |
|             | XVS 650      | 1996-   |   |   |
|             | XVZ 1300     | 1996-   |   |   |
|             | YP 250 MAJES | 1996-   |   |   |
|             | YZF 600      | 1996-   |   |   |
|             | YZF 750 R    | 1993-   |   |   |
|             | YZF 750 SP   | 1993-   |   |   |
|             | YZF 1000     | 1996-   |   |   |
|             | FS 1         | -1986   | YAMA-16D  | YAMA-16D  |
|             | RD 125       | -1986   | YAMA-16I  | YAMA-16I  |
|             |              |   | YAMA-3D   | YAMA-3D   |
|             |              |   | YAMA-3I   | YAMA-3I   |
| FZX 600 R   | 1994         | YAMA-19D  | YAMA-19D  |   |
| TW 200      | 1994         | YAMA-19DP   | YAMA-19DP   |   |
| FZX 600 R   | 1995         | YAMA-19I  | NE-8  |   |
| TW 200      | 1995         | YAMA-23IP   |   |   |
|             |              | YAMA-29P  |   |   |
| FZX 750     | 1995         | YAMA-18D  | NE-8  |   |
|             |              | YAMA-22DP   |   |   |
| RD 350      | -            | YAMA-3D   | YAMA-3D   |   |
| XS 500 B    | 1979-        | YAMA-3I   | YAMA-3I   |   |
|             |              | YAMA-9D   | YAMA-9D   |   |



| MARCA BRAND | MODELO MODEL |  |  |  |
|-------------|--------------|---|---|---|
| YAMAHA      |              |   | YAMA-9I   | YAMA-9I   |
|             | RD 500 LC    | 1984-   | YAMA-18D  | NE-8  |
|             | XJ 550       | 1984-   | YAMA-18DP   | YAMA-21I  |
|             | XS 400       | 1984-   | YAMA-18I  | YAMA-21IP   |
|             |              |   | YAMA-18IP   |   |
|             |              |   | YAMA-19D  |   |
|             |              |   | YAMA-19DP   |   |
|             |              |   | YAMA-19I  |   |
|             |              |   | YAMA-19IP   |   |
|             |              |   | YAMA-20D  |   |
|             |              |   | YAMA-20I  |   |
|             |              |   | YAMA-20IP   |   |
|             |              |   | YAMA-21I  |   |
|             |              |   | YAMA-21IP   |   |
|             |              |   | YAMA-22DP   |   |
|             |              |   | YAMA-22IP   |   |
|             |              |   | YAMA-23DP   |   |
|             |              |   | YAMA-23IP   |   |
|             |              |   | YAMA-24DP   |   |
|             |              |   | YAMA-24IP   |   |
|             |              |   | YAMA-28P  |   |
|             |              |   | YAMA-29P  |   |
|             | RS 125 C.    | -1986   | YAMA-5D   | YAMA-5D   |
|             |              |   | YAMA-5I   | YAMA-5I   |
|             | SR 500 G     | 1979-1984   | YAMA-14I  | NE-8  |
|             | SR 500 S     | 1979-1984   |   |   |
|             | XT 500       | 1979-1984   |   |   |
|             | TDR 125      | 1992-   | YAMA-18I  | ZA-1  |
|             | TDR 125 R    | 1992-   | YAMA-18IP   | ZA-1P   |
|             | TDR 125 R    | 1990-1991   | YAMA-19I  | ZA-1  |
|             |              |   | YAMA-19IP   | ZA-1P   |
|             | TT 600       | 1994  | YAMA-20D  | YAMA-20D  |
|             | TT 600 E     | 1994  |   |   |
|             | XT 600 A     | 1994  |   |   |
|             | XT 600 E     | 1994  |   |   |
|             | TT 600       | 1995  | YAMA-20I  | YAMA-20I  |
|             | XT 600 A     | 1995  | YAMA-24IP   | YAMA-24IP   |
|             | XT 600 E     | 1995  | YAMA-28P  | YAMA-28P  |
|             | XC 125 CYGN. | 1995  | YAMA-18D  | YAMA-18D  |
|             |              |   | YAMA-22DP   | YAMA-22DP   |
|             | XS 500       | 1979-   | YAMA-13D  | YAMA-13D  |
|             | XS 500 EV.   | 1985-   | YAMA-13I  | YAMA-13I  |
| XS 750      | 1979-        | YAMA-13I  | YAMA-13I  |   |
| XS 1100     | 1984-        | YAMA-13D  | NE-8  |   |
| XS 1100 S   | 1984-        | YAMA-13I  |   |   |
| XT 250      | 1990-        | YAMA-17I  | NE-8  |   |
| YPUS 125    | 1990-        |   |   |   |
| XT 400      | -            | YAMA-14D  | NE-8  |   |
| YSR 50      | 1990-        | YAMA-18D  | NE-8  |   |
|             |              | YAMA-18I  |   |   |
|             |              | YAMA-22DP   |   |   |
|             |              | YAMA-22IP   |   |   |



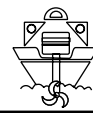
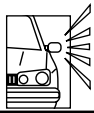

**THE KEY TO EXCELLENCE**  
GLOBALLY UNLOCKING MILLIONS OF DOORS DAILY





| REFERENCIA<br>REFERENCE  | TIPO<br>TYPE  |
|--|---|
| ALP-11<br>ALP-2<br>ALP-2D<br>ALP-6<br>ALP-6D<br>CHI-1T<br>COB-1P<br>COB-2<br>DOM-11D<br>DOM-11I<br>GH-3<br>HU-NW<br>NE-60C1<br>NE-60C2<br>PO-2P<br>STS-X5<br>STS-X6<br>VA-61C1<br>VA-61C2<br>YW-1P<br>ZA-3D<br>ZA-5DP<br>ZA-5P | ALARMA<br>ALARM<br><br>        |
| BOB-1D<br>CN-1D<br>MIT-1D<br>MIT-1DP<br>MIT-1I<br>MIT-1IP<br>MIT-2D<br>MIT-2DP<br>MIT-2I<br>MIT-2IP<br>TOYO-25<br>YA-11D<br>YA-11I<br>YA-27<br>YA-27D  | AVION<br>AEROPLANE<br><br>   |
| ABU-3<br>ABU-13<br>ABU-13D<br>ABU-18DP<br>ABU-18P<br>ABU-19D<br>ABU-19DP<br>ABU-19P<br>ABU-21<br>ABU-35P<br>ABU-36P<br>ABU-40<br>ABU-42<br>ABU-42D<br>ABU-45<br>ABU-64P<br>ABU-65P<br>ABU-72P<br>AF-19<br>AF-19P               | BICICLETA<br>BICYCLE<br><br> |



| REFERENCIA<br>REFERENCE  | TIPO<br>TYPE   |
|--|--|
| AF-21<br>AF-21P<br>AS-2D<br>AS-2I<br>AS-17D<br>AS-21<br>AS-21D<br>AS-21DP<br>AS-21P<br>AX-1<br>AX-1D<br>AX-1DP<br>AX-1P<br>AX-2P<br>AX-3DP<br>AX-4DP<br>CI-4DP<br>CI-4IP<br>CI-5DP<br>CI-5IP<br>COB-1P<br>COB-2<br>FAR-1D<br>FAR-1I<br>FAR-2D<br>FAR-2I<br>FAR-3<br>FAR-3D<br>FAR-4D<br>IMS-3<br>IMS-3P<br>IMS-5<br>IMS-5P<br>IMS-13<br>IMS-13P<br>IN-1<br>IN-4<br>IN-5<br>LAS-2<br>LAS-3<br>LAS-4<br>LAS-4D<br>LAS-5<br>LAS-5D<br>LAS-6<br>LAS-6D<br>LAS-FH<br>LAS-KT<br>LAS-TK<br>LAS-U<br>LAS-X<br>LF-1D<br>LF-1I<br>LF-5<br>LF-5D<br>LF-15<br>LF-15D<br>LF-17<br>LF-32 | BICICLETA<br>BICYCLE<br><br> |

| REFERENCIA<br>REFERENCE   | TIPO<br>TYPE  |
|---|---|
| LUMA-1D<br>LUMA-1I<br>LUMA-2D<br>LUMA-2I<br>LUMA-3D<br>LUMA-3I<br>LUMA-4D<br>LUMA-4I<br>MQ-1D<br>MQ-1I<br>NE-30<br>NE-30P<br>NE-31<br>NE-31P<br>NE-32<br>NE-32P<br>RI-1D<br>RI-1I<br>RI-2D<br>RI-2I<br>RI-3D<br>RI-3I<br>STS-X6<br>TOK-4D<br>UN-1FS<br>UN-2<br>UN-3<br>UN-4<br>UN-44<br>UN-44D<br>UN-FFE<br>UN-FK<br>UN-FP<br>UN-FR<br>UN-FS<br>UN-MRN<br>UN-NG<br>VI-4DP<br>VI-4IP<br>YA-11D<br>YA-11I<br>ZA-1<br>ZA-1P<br>ZA-2P<br>ZA-3D<br>ZA-4DP<br>ZA-10 | BICICLETA<br>BICYCLE<br><br>  |
| AF-19<br>AF-19P<br>AF-21<br>AF-21P<br>AU-AN<br>AU-ANP<br>DOM-3D<br>DOM-3I<br>DOM-4<br>DOM-4D<br>DOM-6D<br>DOM-6I  | CARAVANA<br>CARAVANS<br><br> |



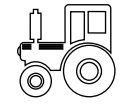
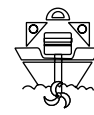
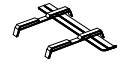



| <b>REFERENCIA<br/>REFERENCE</b>   | <b>TIPO<br/>TYPE</b>   | <b>REFERENCIA<br/>REFERENCE</b>   | <b>TIPO<br/>TYPE</b>   |
|---|--|---|--|
| <b>WAS-5</b><br><b>WAS-5P</b><br><b>WAS-6</b><br><b>WAS-6P</b><br><b>WAS-8</b><br><b>WAS-8D</b> | <b>TAPON DE GASOLINA<br/>PETROL CAP</b><br> | <b>AF-7D</b><br><b>AF-7I</b><br><b>AF-7IP</b><br><b>AF-7IP1</b><br><b>AF-8D</b><br><b>AF-8DP</b><br><b>AF-8I</b><br><b>AF-8IP</b><br><b>AF-9D</b><br><b>AF-9DP</b><br><b>AF-9I</b><br><b>AF-9IP</b><br><b>BH-1</b><br><b>BH-1P</b><br><b>BH-2</b><br><b>BH-3</b><br><b>BH-4</b><br><b>BH-5</b><br><b>BH-6</b><br><b>BH-8</b><br><b>CAT-1P</b><br><b>CIT-2</b><br><b>DAE-5P</b><br><b>DAV-1</b><br><b>DAV-1P</b><br><b>FIA-1</b><br><b>FO-35</b><br><b>FO-36</b><br><b>JD-1</b><br><b>JD-2</b><br><b>JD-3D</b><br><b>JD-4D</b><br><b>MAK-1</b><br><b>MERI-1D</b><br><b>MERI-1DP</b><br><b>PRE-1I</b><br><b>PRE-3</b><br><b>TEU-1</b><br><b>TOYO-27</b> | <b>TRACTOR</b><br><b>TRACTOR</b><br> |







#### JMA HEADQUARTERS ALEJANDRO ALTUNA, S.A.

Tel +34 943 79 30 00  
Fax +34 943 79 72 43  
Bidekuruzeta, 6  
P.O.Box - Apdo. 70  
20500 Arrasate - Mondragón  
Gipuzkoa - SPAIN

www.jma.es  
ventas@jma.es

#### JMA ARGENTINA

JMA ARGENTINA S.A.  
Tel +54 336 4 462 422  
Fax +54 336 4 462 422  
Av. Central Acero Argentino Oeste 678  
Parque industrial COMIRSA  
2900 San Nicolas (Prov. Buenos Aires)

www.jma-argentina.com.ar  
info@jma-argentina.com.ar

#### JMA FRANCE

Tel +33 01 39 22 42 10  
Fax +33 01 39 22 42 11  
Technoparc  
13, rue Edouard Jeanneret  
F-78306 Poissy Cedex

www.jmafrance.fr  
service.commercial@jmafrance.fr

#### JMA INDIA

JMA KEYS INDIA PVT. LTD  
Tel +91 124 428 5450  
Fax +91 124 428 5451  
H-239 & H-240, Sushant Shopping Arcade  
Sushant Lok-1, Block B  
122002 Gurgaon  
Haryana

www.jmakeys.in  
info@jmakeys.in

#### JMA MAROC

JMA MAROC S.A.R.L.  
Tel +0520 150 535  
Fax +0520 150 536  
83,85 Bd Oued ZIZ, El Oulfa

Casablanca  
Marrocos

www.jma.ma  
jma@jma.ma

#### JMA MEXICO

LLAVES ALTUNA DE MEXICO S.A de C.V.  
Tel +52 33 3777 1600  
Fax +52 33 3777 1609  
Av. Aviación No. 5520  
Col. San Juan de Ocotán  
C.P. 45019 Zapopan, Jalisco

www.jma.com.mx  
ventas@jma.com.mx

#### JMA PERÚ

JMA Perú S.A.C.  
Tel +51 639 9300  
Av. Los Paracas 130, Urbanización Salamanca,  
Distrito Ate, Lima

www.jma-peru.com  
info@jma-peru.com

#### JMA POLSKA

JMA POLSKA Sp. z o.o.  
Tel +48 42 635 12 80  
Fax +48 42 635 12 85  
91-342 Łódź, ul. Zbąszyńska 3

www.jmapolska.pl  
biuro@jmapolska.pl

#### JMA PORTUGAL

ALTUNA PORTUGAL  
COMERCIO DE CHAVES UNIPessoal, LDA.  
Tel +351 219 947 470  
Fax +351 219 947 471  
Urbanização dos Azeiros, Lote 67 C/v  
2695-733 São João da Talha

www.jmaportugal.com  
comercial@jmaportugal.com

#### JMA UK

SKS LTD  
Tel +44 144 229 1400  
Fax +44 144 286 3663  
Unit 2, Canal Side  
Northbridge Road  
Berkhamsted  
Herts HP4 1EG

www.jmakeys.co.uk  
sales@skskkeys.co.uk

#### JMA URUGUAY

JMA URUGUAY S.A.  
Tel +598 2908 1175  
Fax +598 2900 6681  
Mercedes 1420  
11100 Montevideo  
Uruguay

www.jma.com.uy  
info@jma.com.uy

#### JMA USA

ALTUNA GROUP USA INC.  
Tel +1 817 385 0515  
Fax +1 817 385 4850  
1513 Greenview Drive  
75050 Grand Prairie, Texas

www.jmausa.com  
info@jmausa.com